

# ASSEMBLY INSTRUCTIONS



*Fine Furniture for every stage of life*

**(B1&B2)**  
**Dining Table**

# ASSEMBLY INSTRUCTIONS

## ASSEMBLY TIPS:

1. Remove hardware from box and sort by size.
2. Please check to see that all hardware and parts are present prior to start of assembly.
3. Please follow attached instructions in the same sequence as numbered to assure fast & easy assembly.



### WARNING!

1. Don't attempt to repair or modify parts that are broken or defective. Please contact the store immediately.
2. This product is for home use only and not intended for commercial establishments.





ASSEMBLY TIME

25 MINUTES

## PART IDENTIFICATION

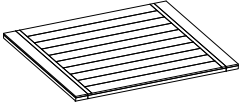
### B1 (BOX 1)

AN	TOP		1PC
CN	TRESTLE BAR		1PC
DN	LEAF		2PCS

### B2 (BOX 2)

BN	BASE		2PCS
----	------	---	------

## HARDWARE IDENTIFICATION

(BOX 1) - HARDWARE PACK IS LOCATED IN (B1)

1	<b>THREADED BOLT</b> (5/16" x 100mm - WHT)		2PCS
2	<b>HALF ROUND NUT</b> (22 x 17 x 10mm - WHT)		2PCS
3	<b>HEX NUT</b> (5/16" x 12 - BLK)		2PCS
4	<b>HEX BOLT</b> (5/16" x 50mm - BLK)		8PCS
5	<b>LOCK WASHER</b> (1.6 x 14mm - BLK)		8PCS
6	<b>FLAT WASHER</b> (1 x 18mm - BLK)		8PCS
7	<b>WRENCH</b> (M12 - RBW)		1PC
8	<b>WOOD DOWEL</b> (10 x 40mm - BRW)		4PCS

### NOTE:

Phillips head screw driver is required in the assembly process; however, manufacturer does not provide this item.

# ASSEMBLY INSTRUCTIONS

## STEP 1

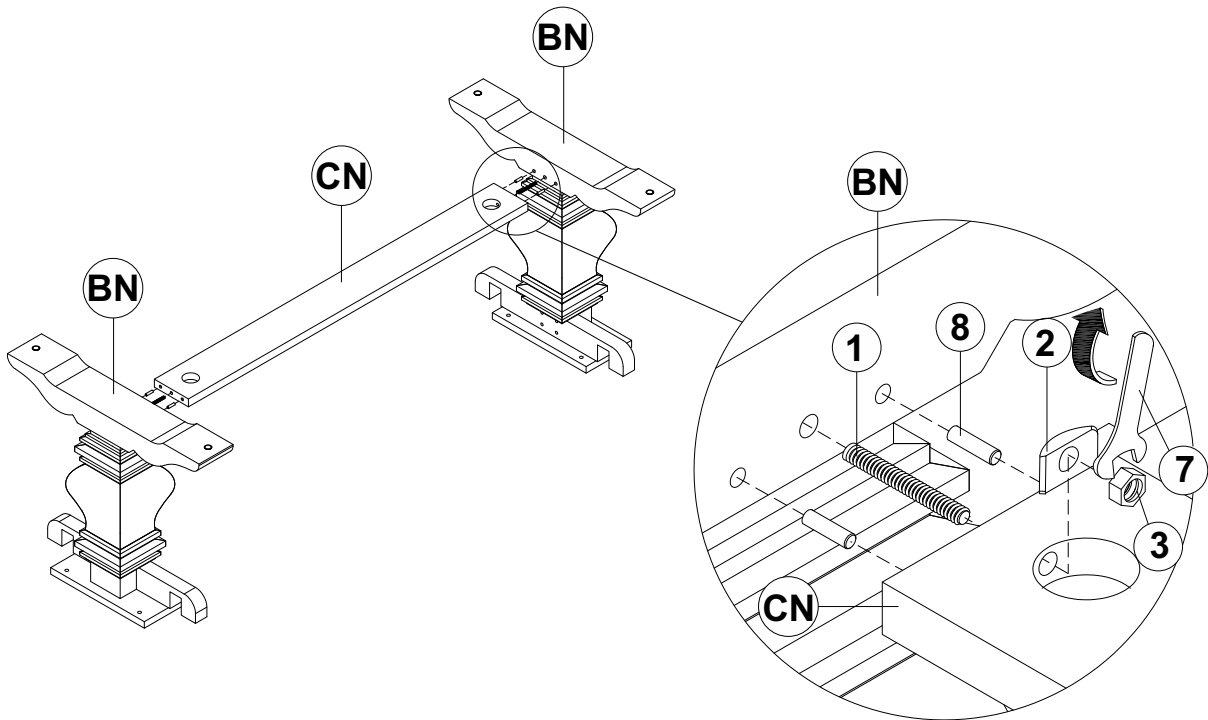

## STEP 2

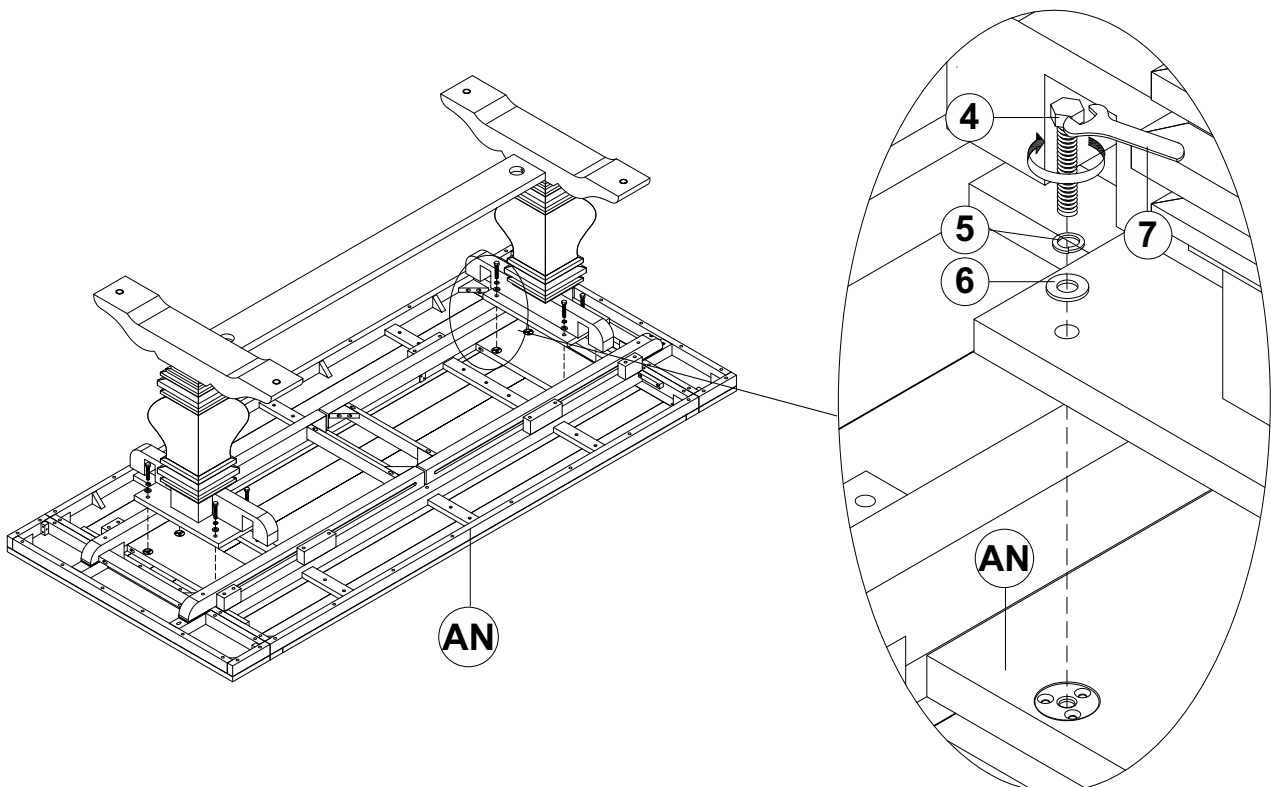

# ASSEMBLY INSTRUCTIONS

## STEP 3

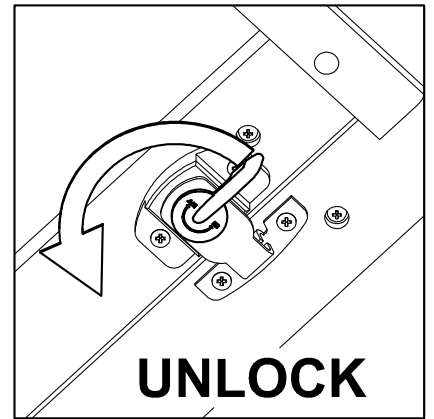
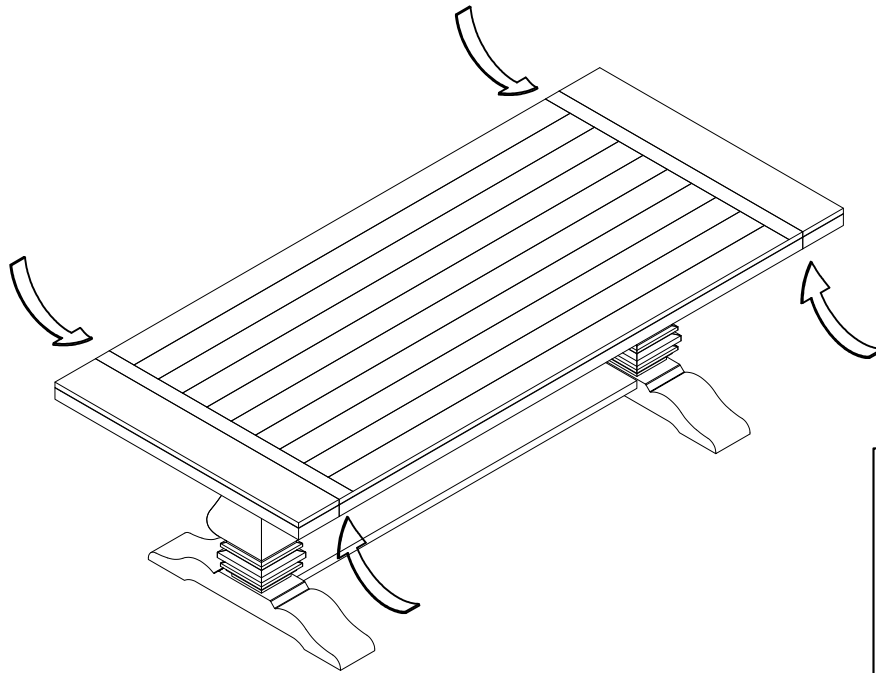

## STEP 4

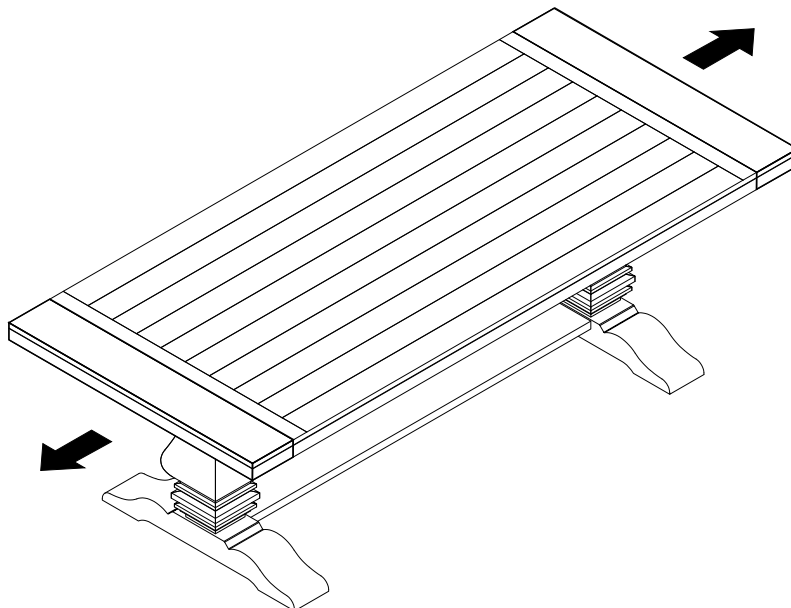

# ASSEMBLY INSTRUCTIONS

## STEP 5

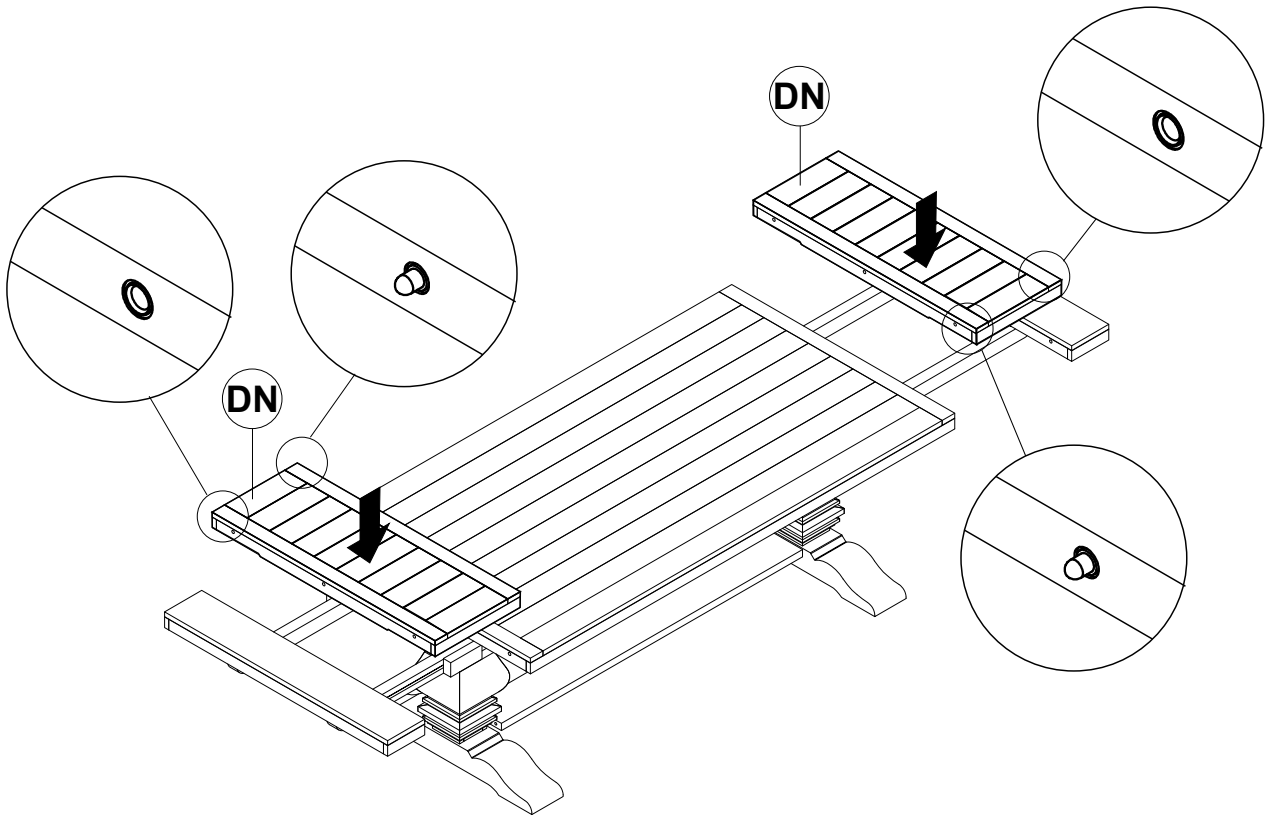

## STEP 6

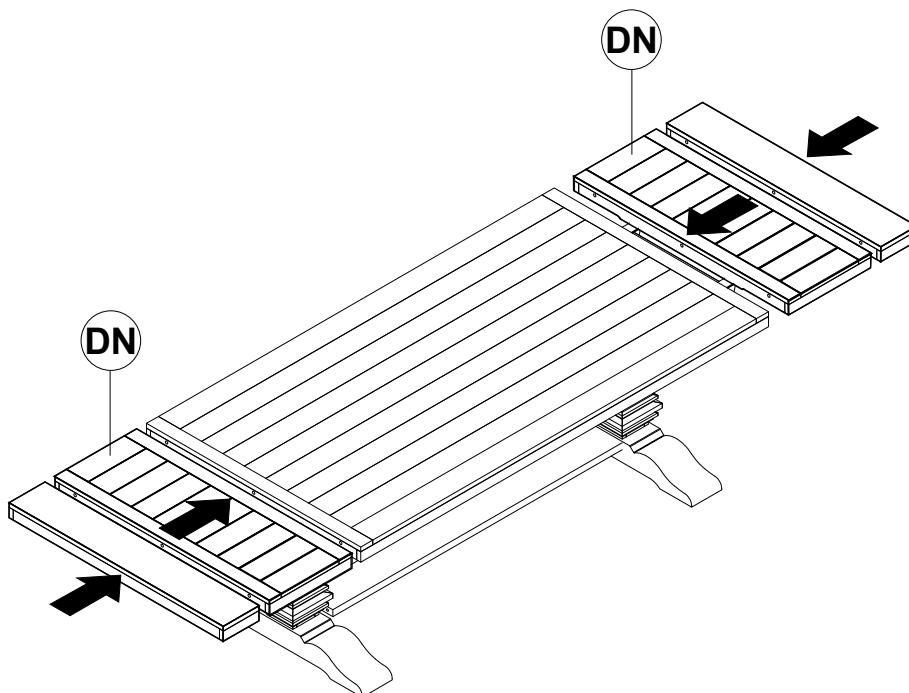

# ASSEMBLY INSTRUCTIONS

## STEP 7

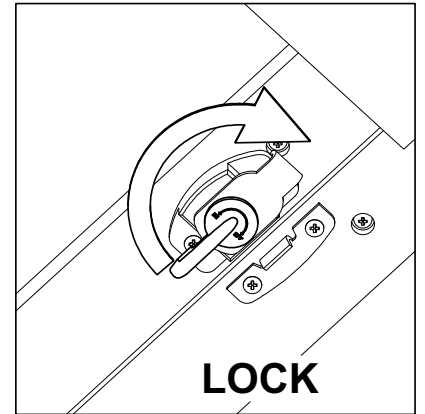
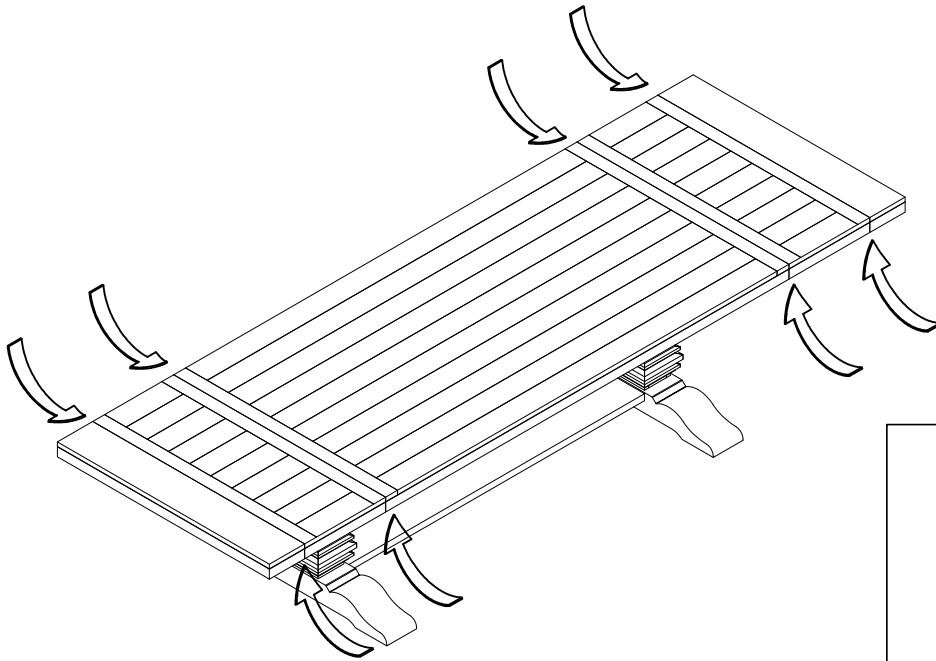

## STEP 8 COMPLETE

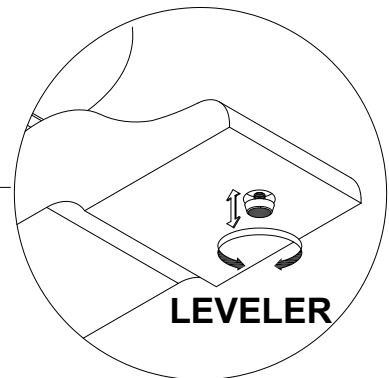
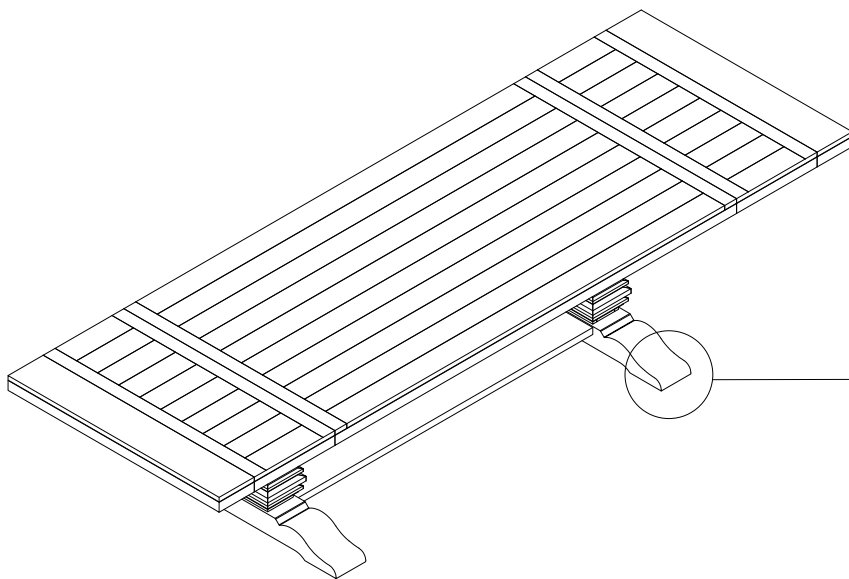

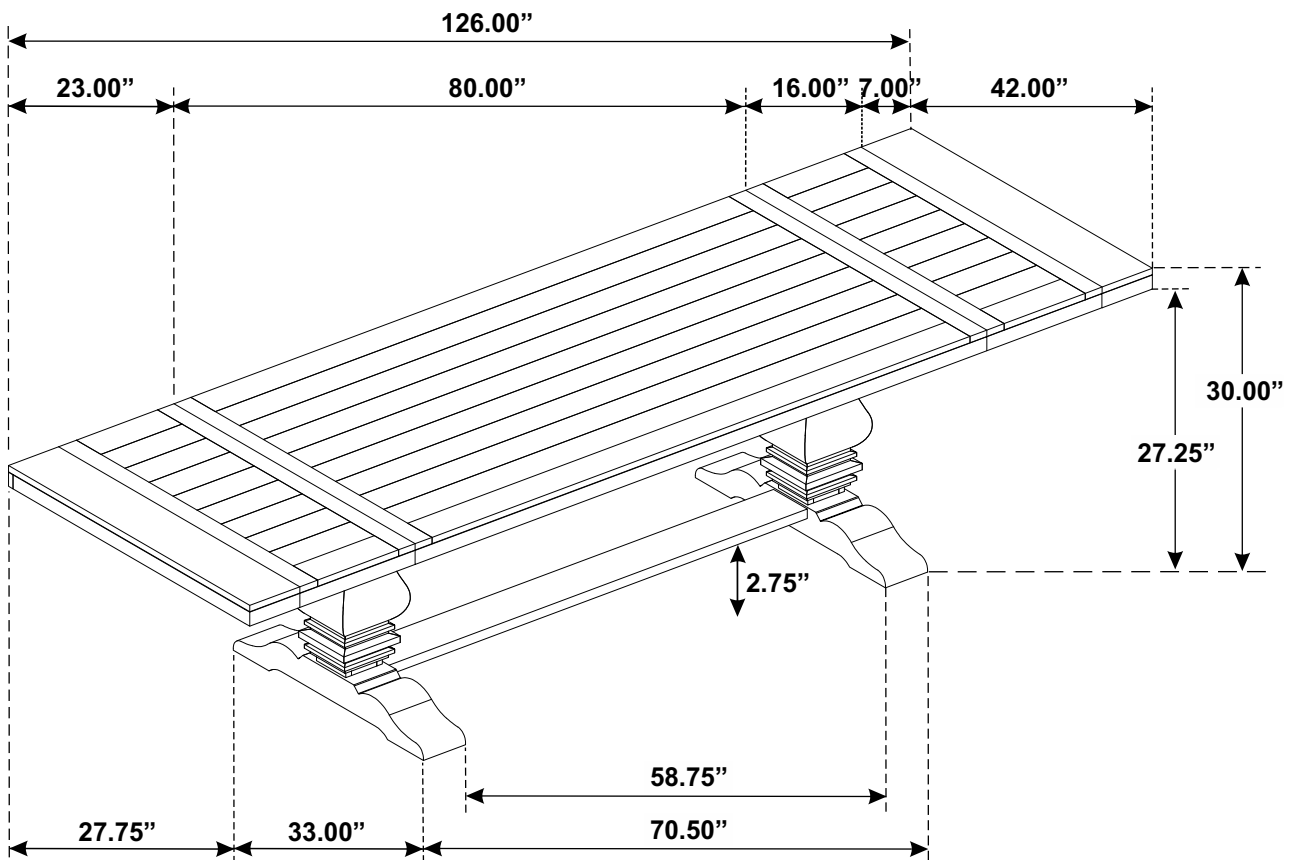

**Note: Dimension tolerance  $\pm 5\%$**

# ASSEMBLY INSTRUCTIONS



*Fine Furniture for every stage of life*

**Side Chair**

# ASSEMBLY INSTRUCTIONS

## ASSEMBLY TIPS:

1. Remove hardware from box and sort by size.
2. Please check to see that all hardware and parts are present prior to start of assembly.
3. Please follow attached instruction in the same sequence as numbered to assure fast and easy assembly.



### WARNING !



1. Don't attempt to repair or modify parts that are broken or defective. Please contact the store immediately.
2. This product is for home use only and not intended for commercial establishment.





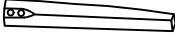

ASSEMBLY TIME

15 MINUTES

## PARTS IDENTIFICATION

A	SEAT AND BACK		1PC
B	FRONT LEG		2PCS
C	BACK LEG		2PCS

## HARDWARE IDENTIFICATION

1	LONG BOLT (M8 x 60mm - BLK)		4PCS
2	SHORT BOLT (M8 x 50mm - BLK)		4PCS
3	LOCK WASHER (M8 - BLK)		8PCS
4	FLAT WASHER (M8 - BLK)		8PCS
5	ALLEN WRENCH (M5 - BLK)		1PC

# ASSEMBLY INSTRUCTIONS

## STEP 1

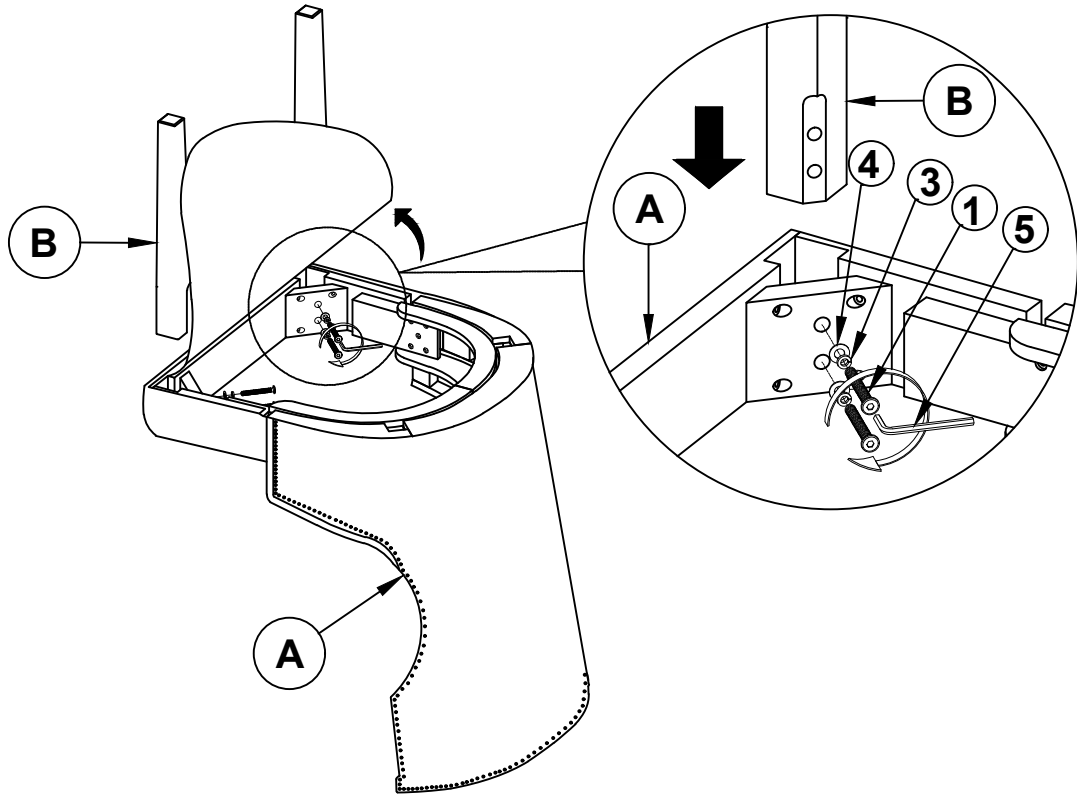

## STEP 2

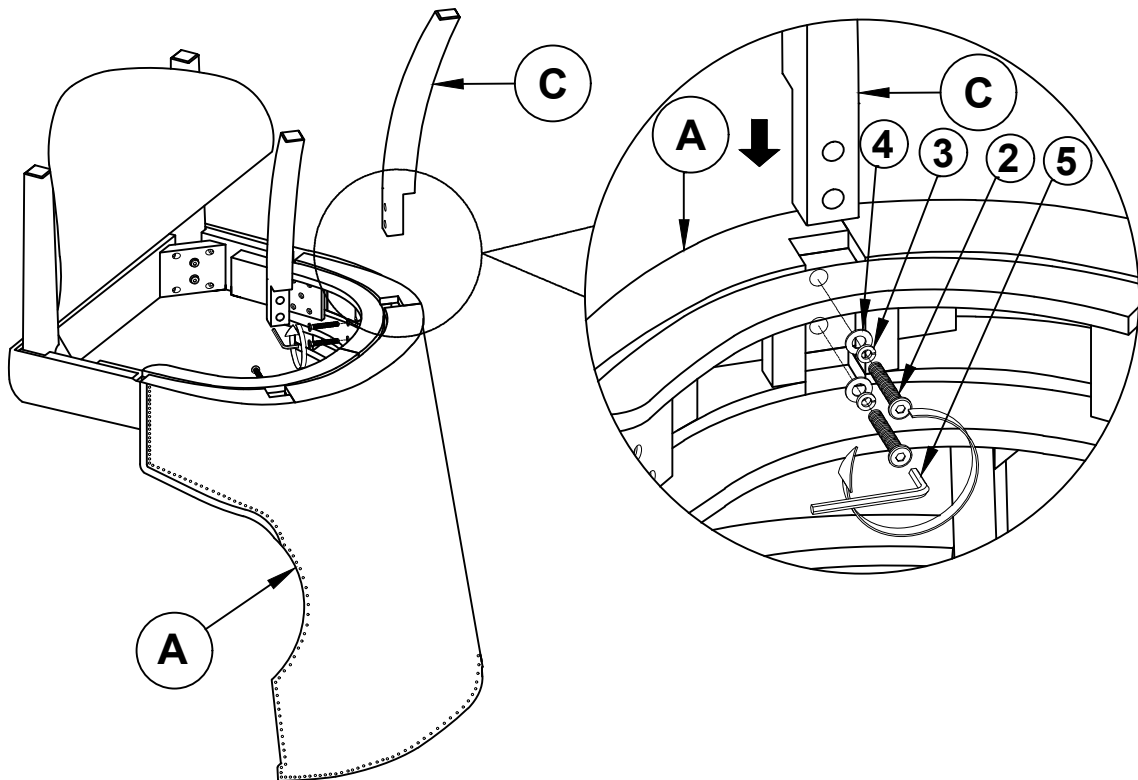

# ASSEMBLY INSTRUCTIONS

## STEP 3

## COMPLETE

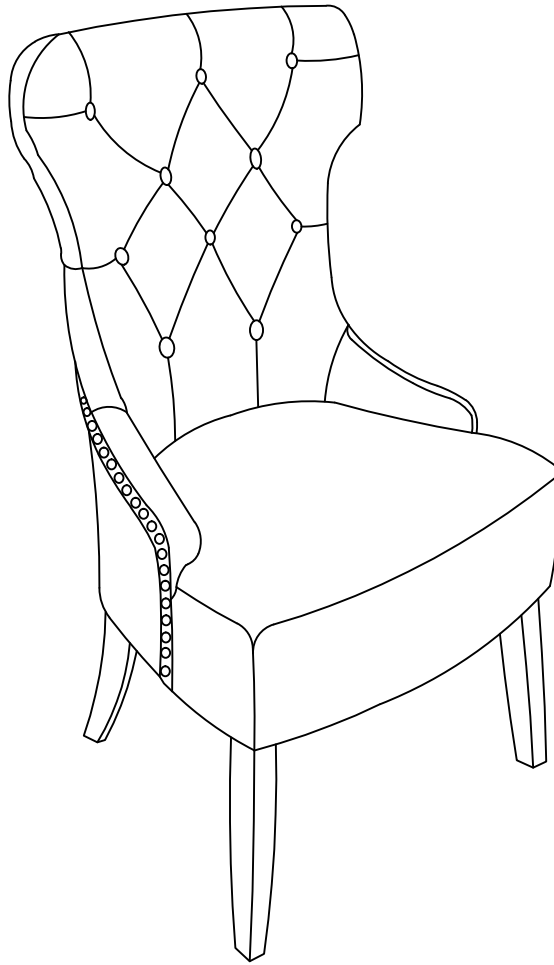

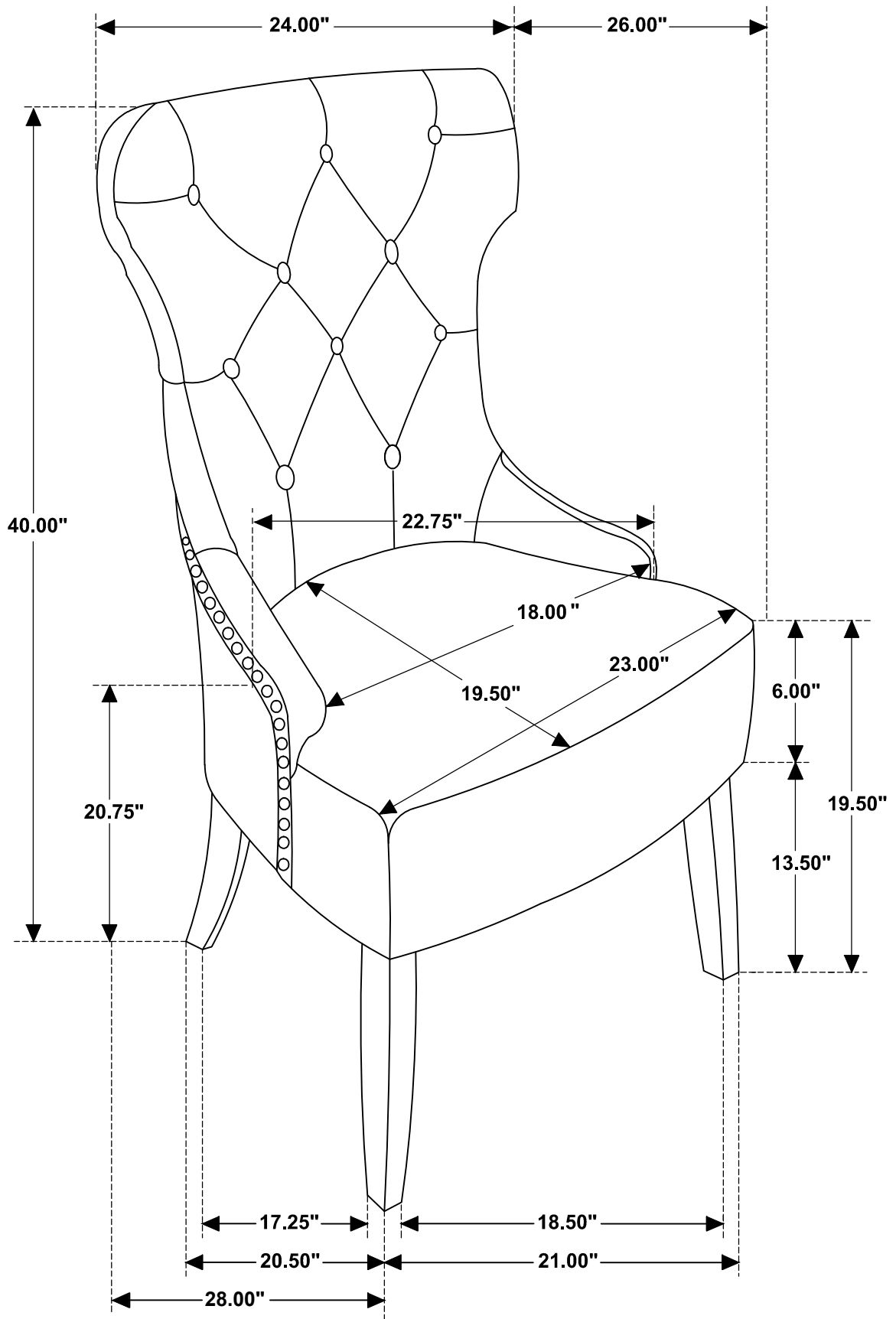

**Note : Dimension tolerance  $\pm 5\%$**