

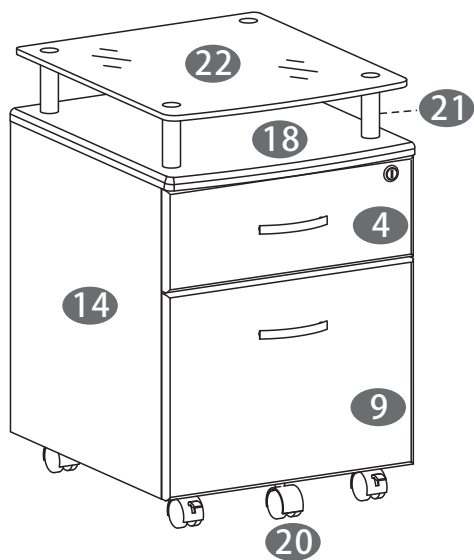

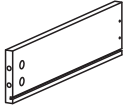

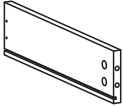



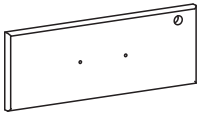
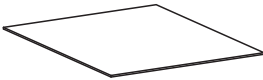

IMPORTANT, RETAIN FOR FUTURE REFERENCE: READ CAREFULLY

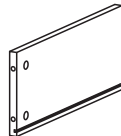
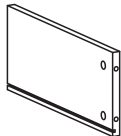
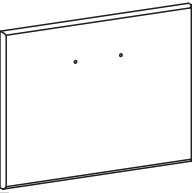
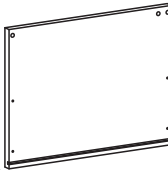
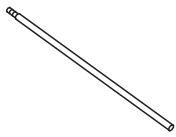
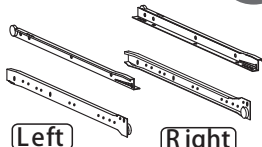
ASSEMBLY INSTRUCTION

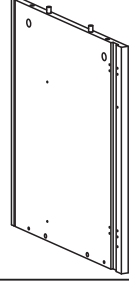
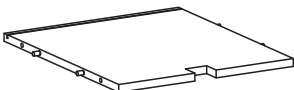
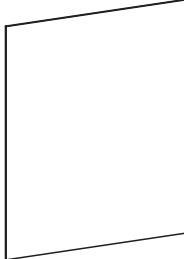
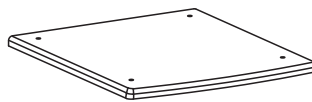
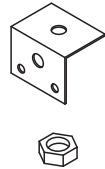
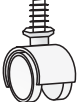

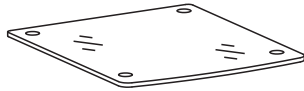
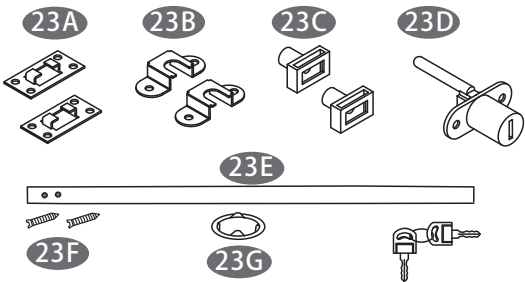
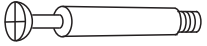
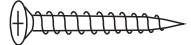
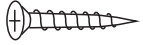
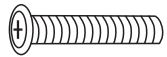
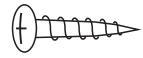
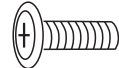

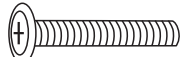
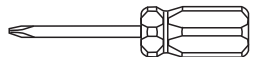
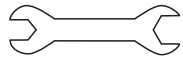
 <p>1</p>	 <p>2</p>
<p>X1</p>	<p>X1</p>
 <p>3</p>	 <p>4</p>
<p>X2</p>	<p>X1</p>
 <p>5</p>	 <p>6</p>
<p>X2</p>	<p>X1</p>
 <p>7</p>	 <p>8</p>
<p>X1</p>	<p>X1</p>
 <p>9</p>	 <p>10</p>
<p>X1</p>	<p>X1</p>
 <p>11</p>	 <p>12</p>
<p>X2</p>	<p>X2</p>
 <p>13</p>	 <p>14</p>
<p>X2</p>	<p>X1</p>
 <p>15</p>	 <p>16</p>
<p>X1</p>	<p>X1</p>
 <p>17</p>	 <p>18</p>
<p>X1</p>	<p>X1</p>
 <p>19</p>	 <p>20</p>
<p>X1</p>	<p>X1</p>
 <p>21</p>	 <p>22</p>
<p>X4</p>	<p>X1</p>
 <p>23A 23B 23C 23D 23E 23F 23G</p>	
<p>X1</p>	

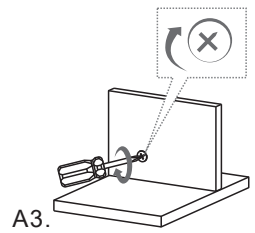
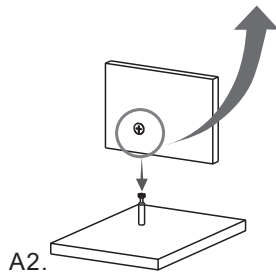
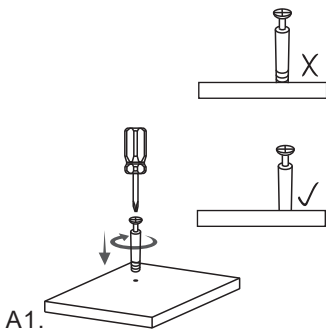
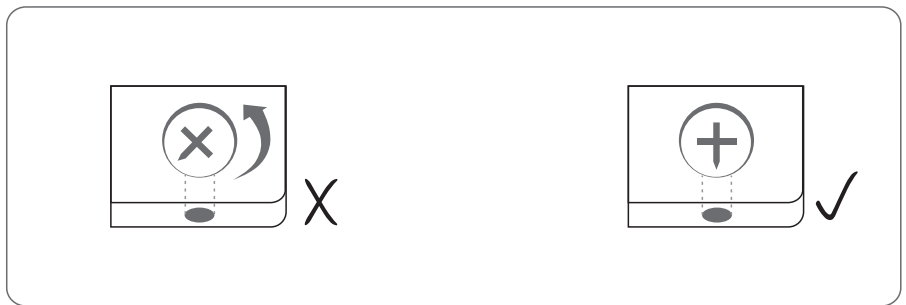
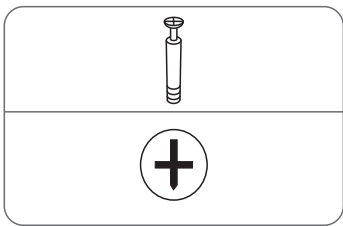
 <p>A x 16 6x40mm +1 (spare)</p>	 <p>B x 8 4x35mm +1 (spare)</p>	 <p>C x 30 3x15mm +1 (spare)</p>
 <p>D x 4 4x20mm +1 (spare)</p>	 <p>E x 18 4x14mm +1 (spare)</p>	 <p>F x 1 6x12mm</p>
 <p>G x 4 6x20mm +1 (spare)</p>	 <p>H x 4 6x35mm +1 (spare)</p>	 <p>I x 1</p>
 <p>J x 1</p>		



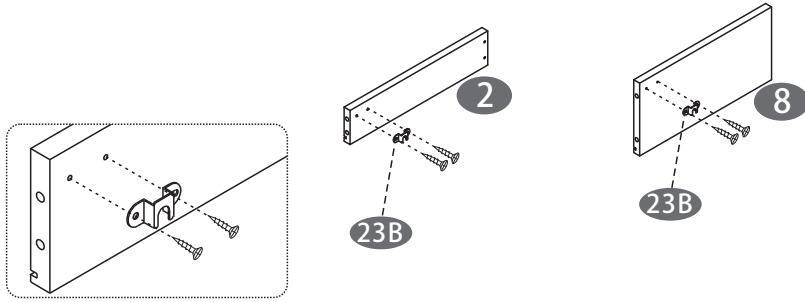

01



C 3X15 MM
 X4

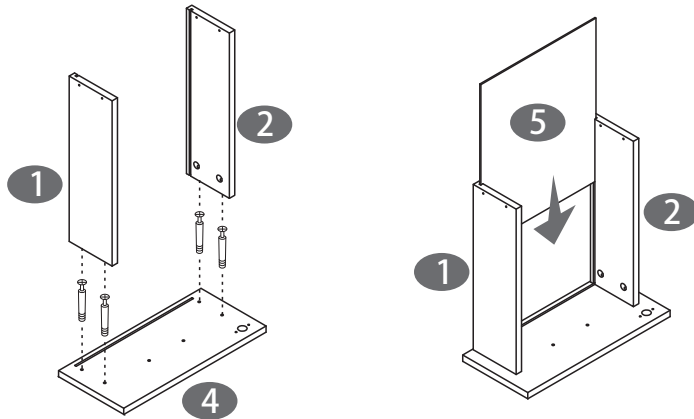
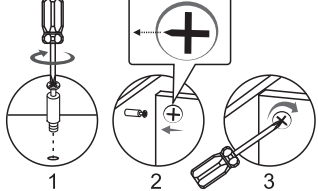

02

A 6X40 MM
 X4

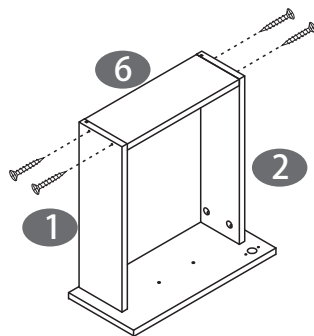

03



B 4X35 MM
 X4

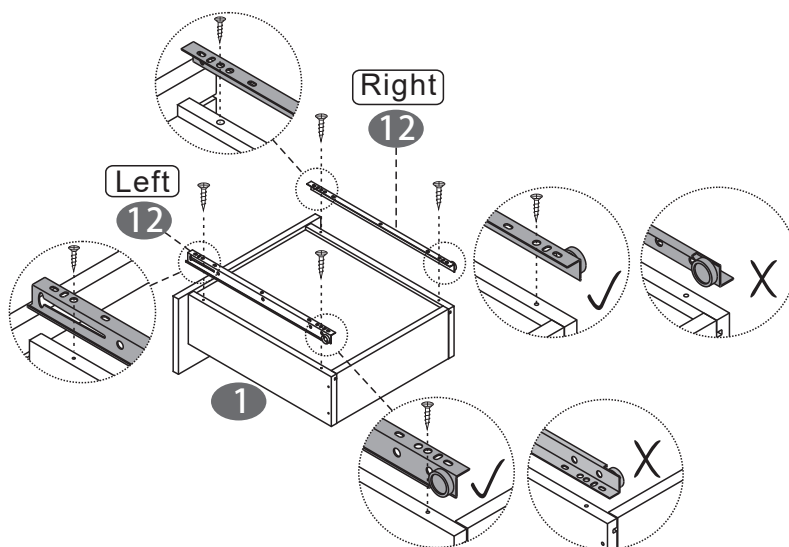

04



C 3X15 MM
 X4

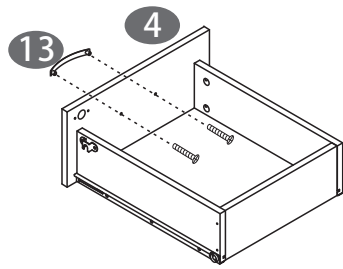

05



D 4X20 MM
 X2 

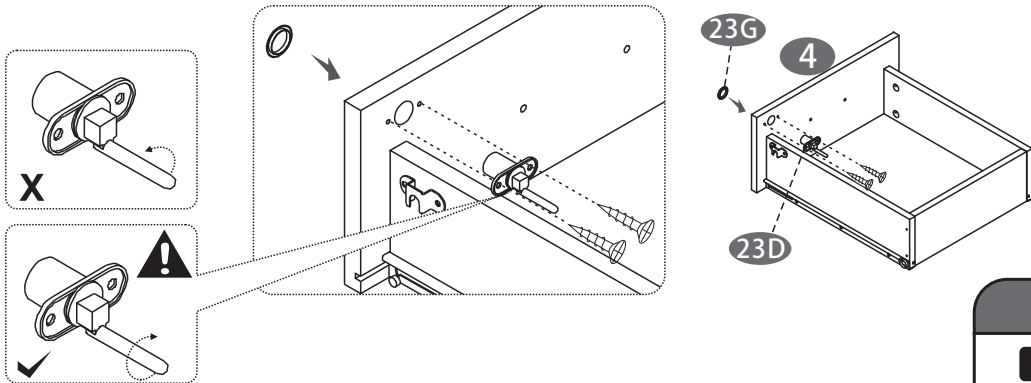

06



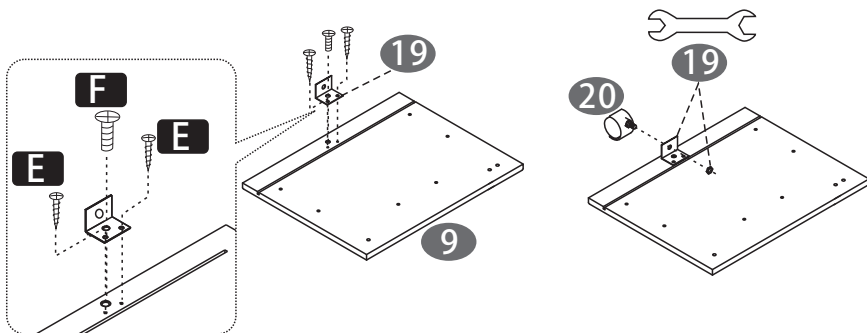

C 3X15 MM
 X2 

07





E 4X14 MM
 X2 

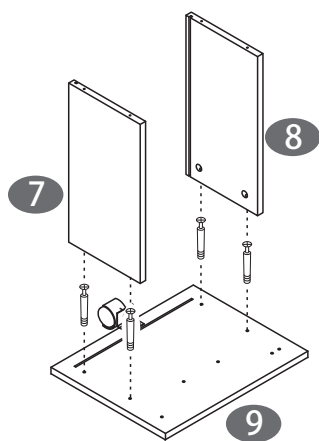
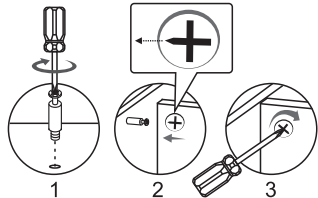

F 6X12 MM
 X1 

08

A 6X40 MM
 X4 

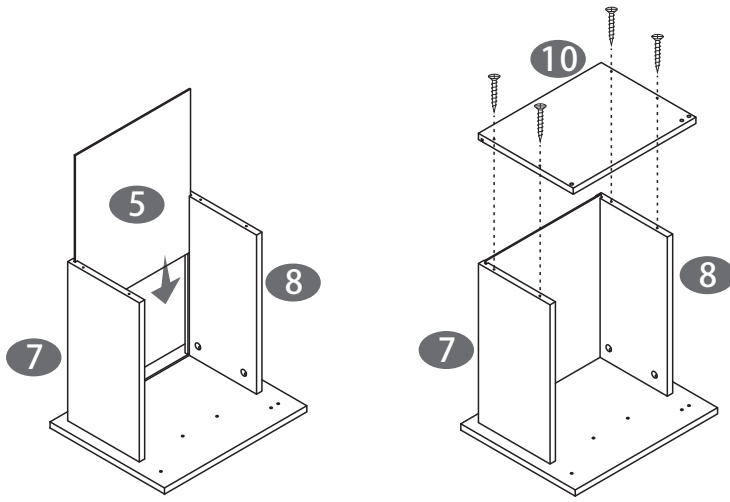



B 4X35 MM
 X4

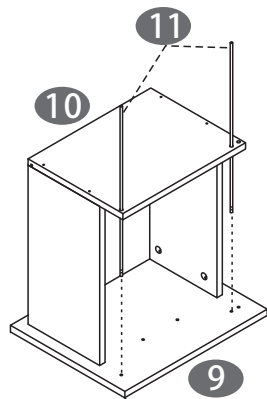

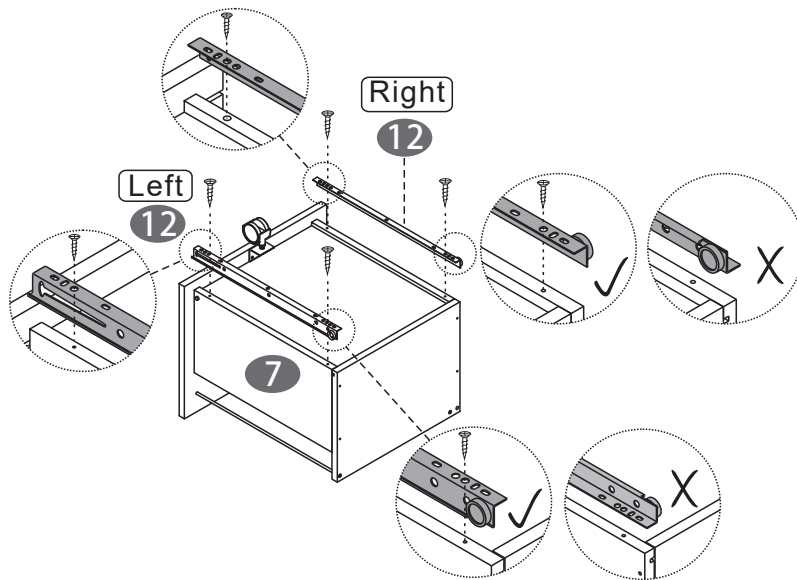

⚠ Be careful not to overtighten the metal rod

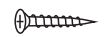
⚠ Attention à ne pas trop serrer la tige métallique



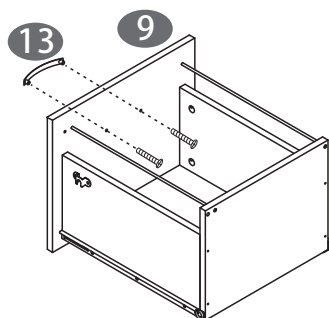

C 3X15 MM
 X4



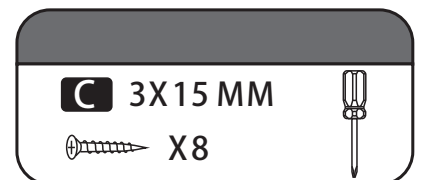
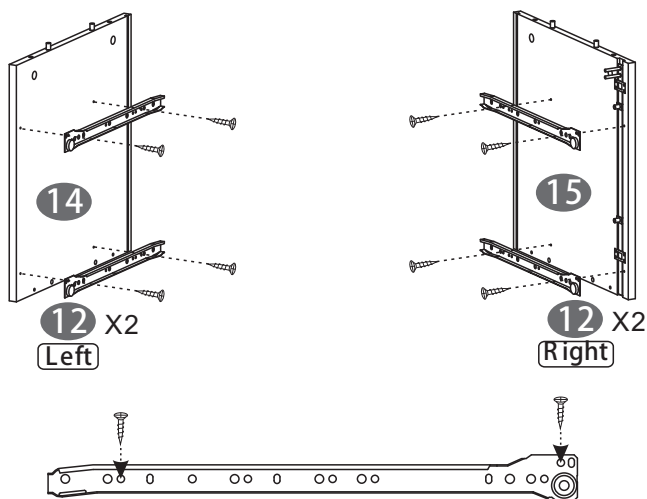
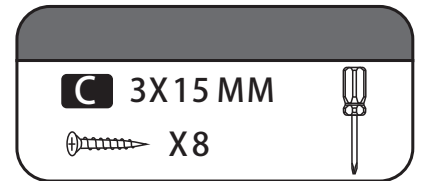
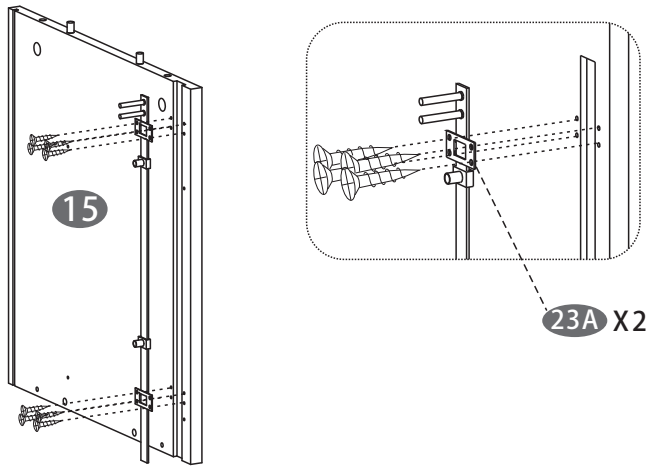
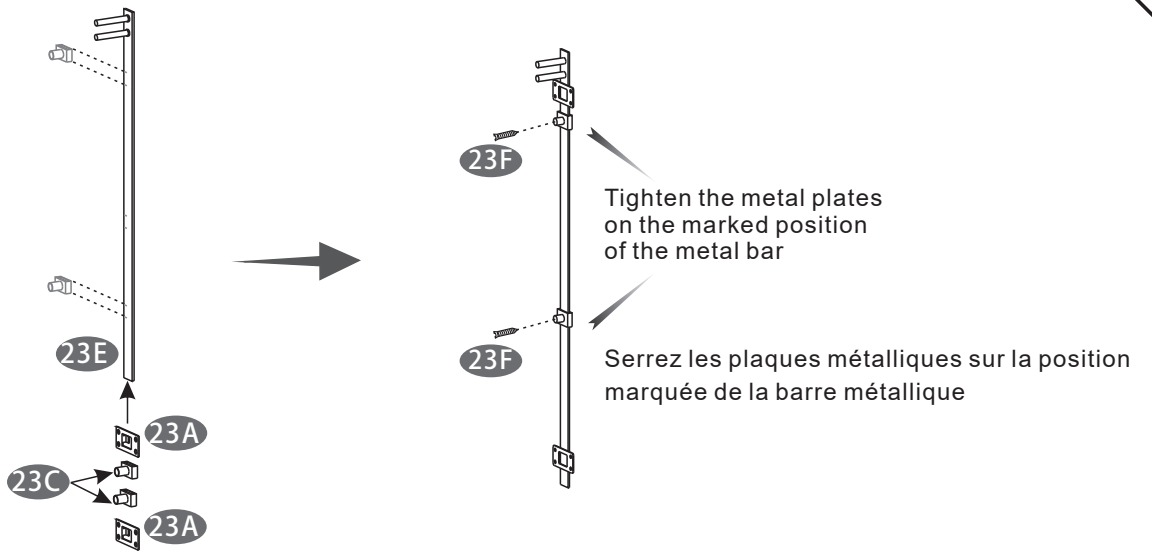

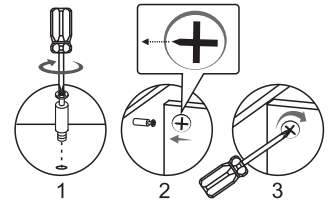
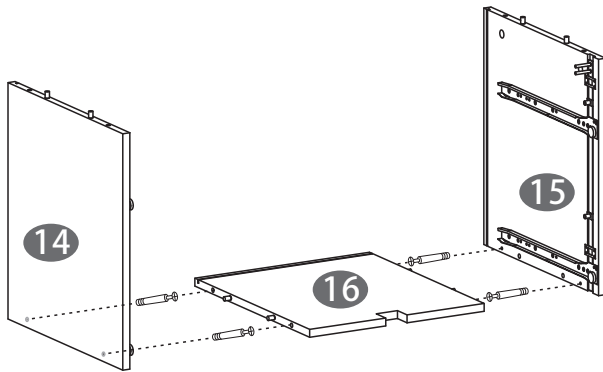
D 4X20 MM
 X2

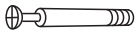



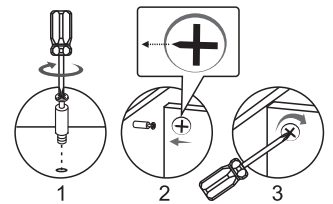
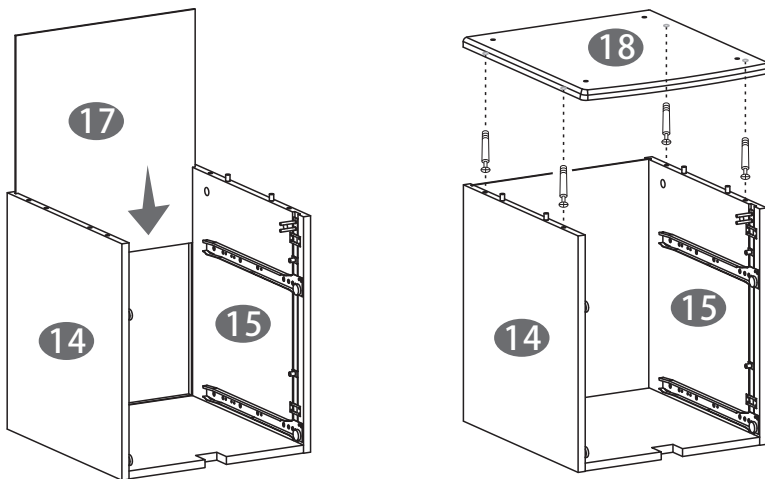

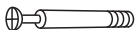
A 6X40 MM
 X4



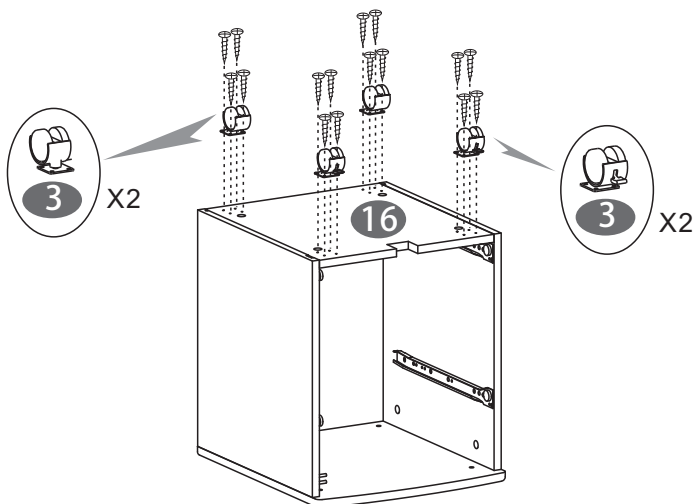

A 6X40 MM
 X4



E 4X14 MM
 X16

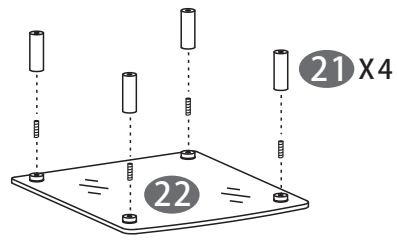

19

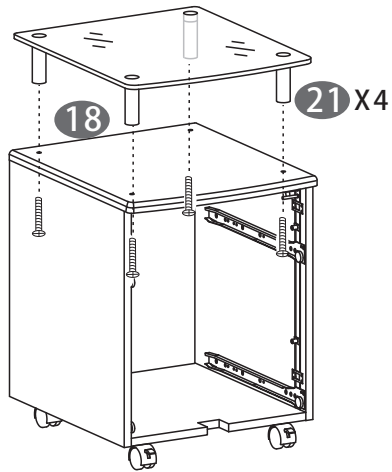

G 6X20 MM
 X4

20



H 6X35 MM
 X4 

21

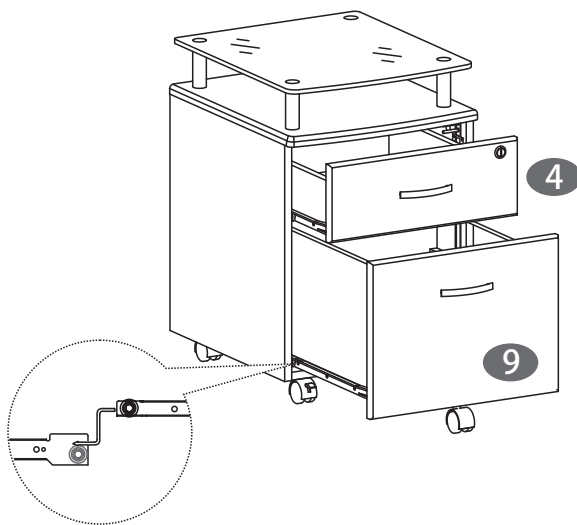

22

