

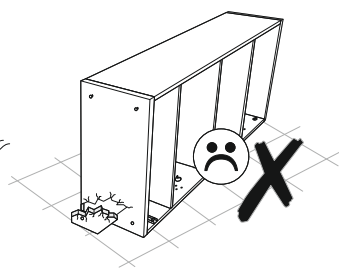

110 min

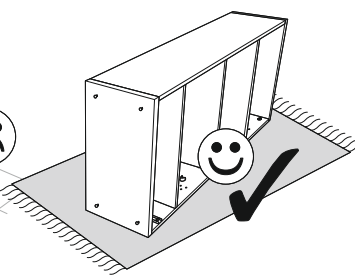

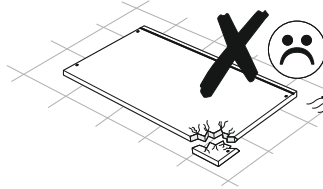
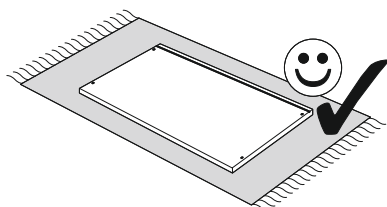
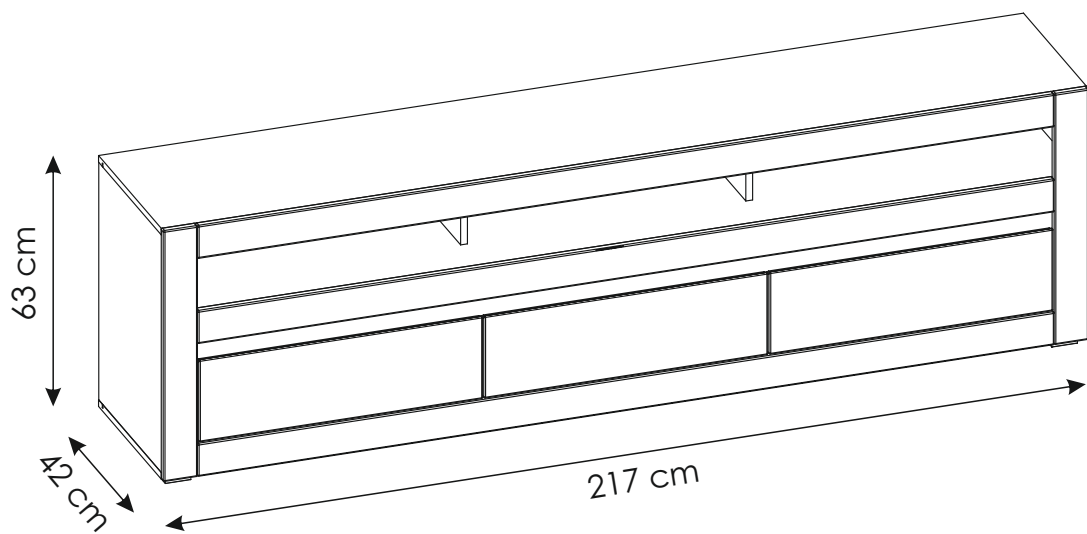
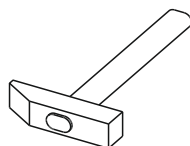
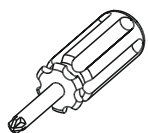
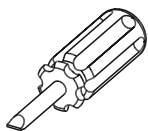
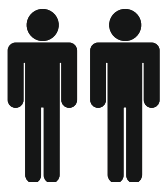
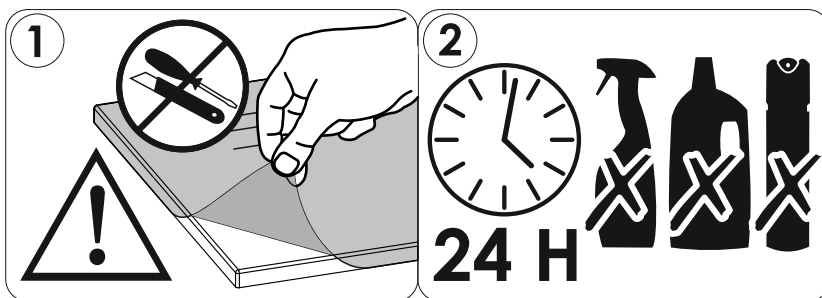
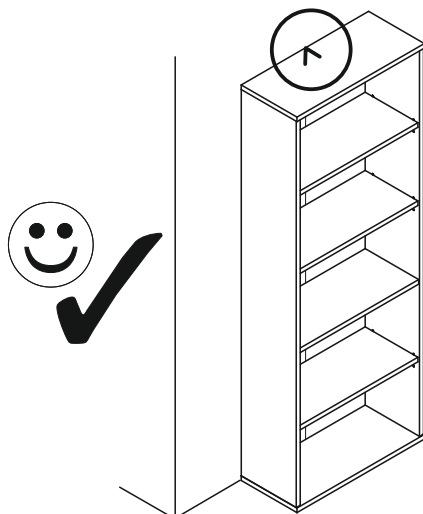

PL.
UWAGA! Mebel należy trwale zamocować do ściany, aby uniknąć ryzyka związanego z przewróceniem się mebla.
W paczce nie ma śrub mocujących, ponieważ rodzaj mocowania należy odpowiednio dobrać do rodzaju ściany. Dobierz właściwe do Twojego rodzaju ściany.

SK.
POZOR! Nábytok musí byť trvalo pripevnený k stene tak, aby sa zamedzilo riziku prevrátenia. Balík neobsahuje upevňovacie skrutky, pretože typ upevnenia je treba vybrať podľa typu steny. Vyberte typ vhodný pre Vašu stenu.

FR.
ATTENTION! Ce meuble doit être fixé en permanence au mur pour éviter les risques de chute. Les vis de fixation ne sont pas livrées car le type de fixation doit être choisi en fonction du type de mur. Sélectionnez les fixations adaptées au mur.

HU.
FIGYELEM! Rögzítse a bútorokat a falhoz, hogy elkerülje a bútor felborulásának kockázatát. A készletben nem találhatóak rögzítőcsavarok, mivel a rögzítés típusa a fal típusától függ. Válassza ki a fal típusának megfelelő kötőelemeket.



HR.
NAPOMENA! Namještaj mora biti trajno pričvršćen za zid, kako bi se izbjegao rizik od njegovog prevrtanja. U paketu nema vijaka za pričvršćivanje, jer se vrsta montaže mora prilagoditi vrsti zida. Odaberite pravu vrstu prema Vašoj vrsti zida.

EN.
WARNING! To prevent this furniture from tripping over, fix it to the wall permanently. Fixing devices are not included since different wall materials require different types of fixing devices. Please make sure you chose the correct ones for your type of wall.

D.
ACHTUNG! Um alle mit dem Umkippen des Möbels verbundenen Risiken auszuschließen, muss das Möbel fest an der Wand verankert werden. Beschläge für die Wandbefestigung sind nicht beige packt, da diese von der jeweiligen Wandbeschaffenheit abhängig sind. Bitte solche Befestigungschläge wählen, die für die heimischen Wände geeignet sind.

CZ.
POZOR! Nábytek je nutné pevně připravit ke zdi, abychom se vyhnuli riziku spojenému s jeho převrnutím. Součástí balení nejsou upevňovací šrouby, protože způsoby připevnění je nutné zvolit podle druhu stěny. Vyberte správný pro Váš typ stěny.

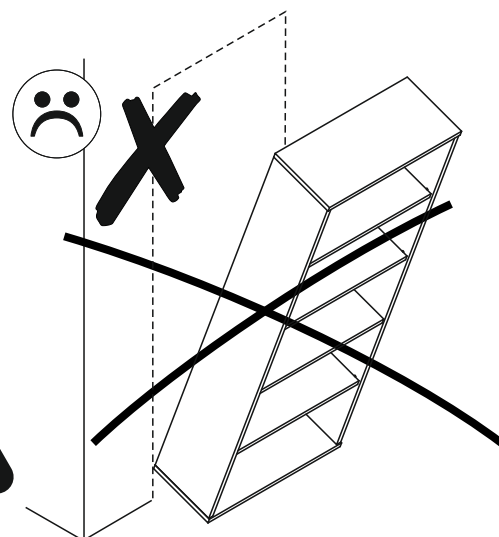

E.
¡ATENCIÓN! El mueble debe ser fijado permanentemente a la pared para evitar el riesgo relacionado con el vuelco del mueble. En el paquete no hay tornillos de fijación, ya que se debe elegir el tipo de fijación adecuado para el tipo de pared. Elija el apropiado para su tipo de pared.









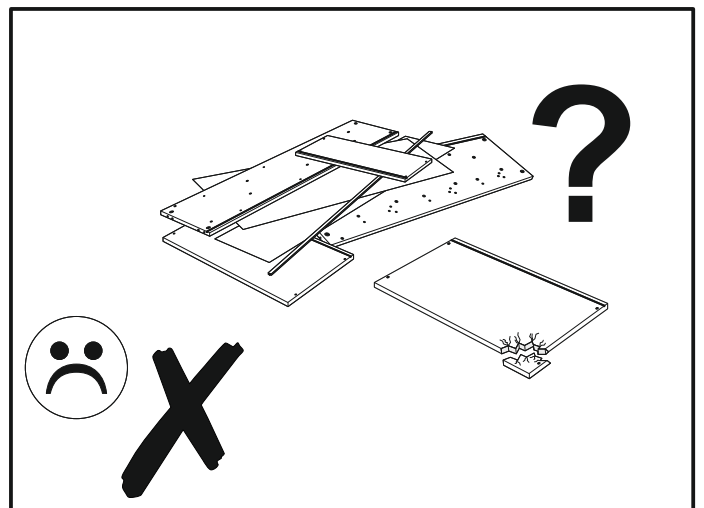
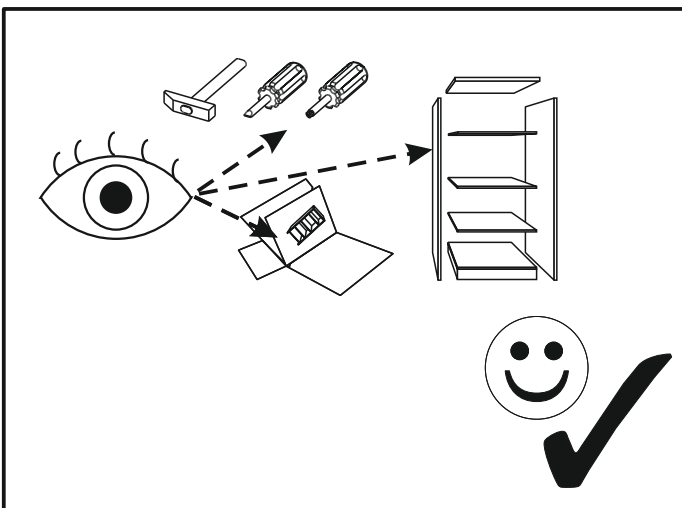
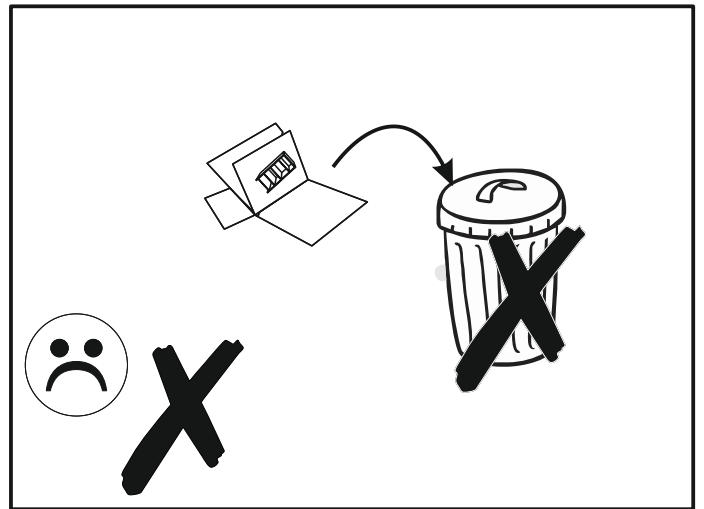
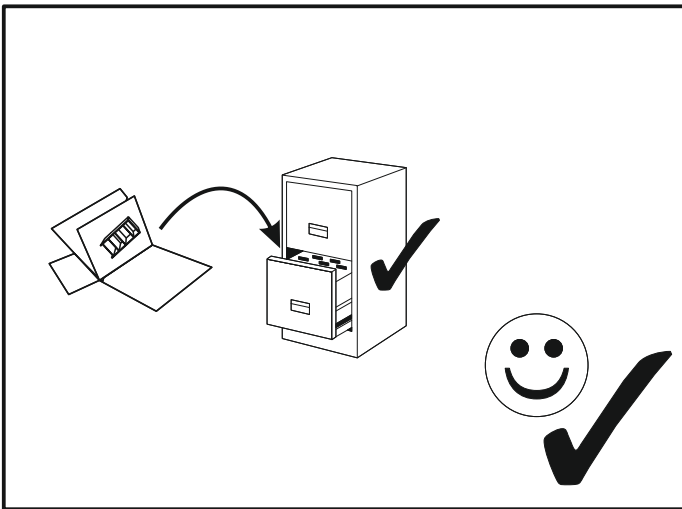
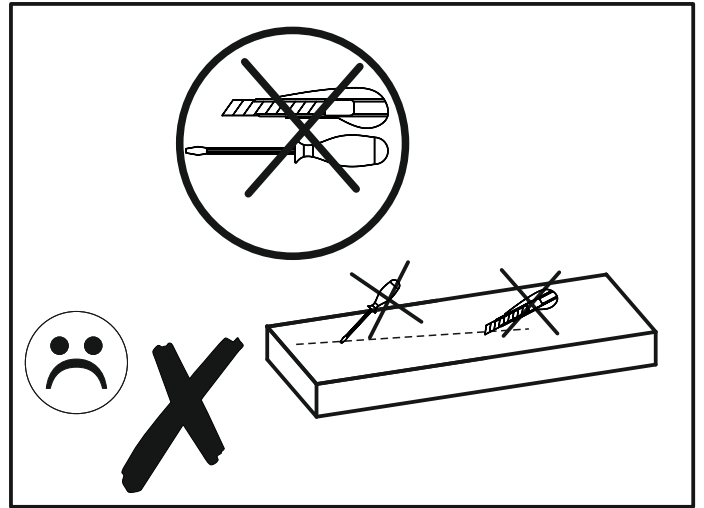
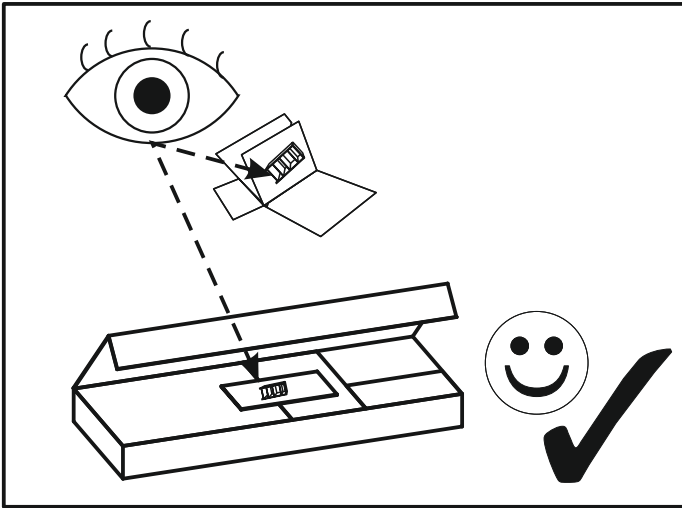





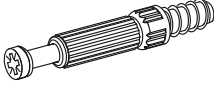

CN.
注意！本家具需要固定在墙上以免倒塌。箱子里没有安装螺钉。因为安装方式需要根据墙的类型调整。请按照您的墙类型选择合适的安装方式。

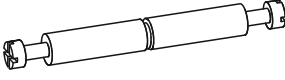
RU.
ПРИМЕЧАНИЕ! Эту мебель необходимо всегда прикреплять к стене, чтобы избежать рисков, связанных с переворотом мебели. В пакете нет крепежных винтов, потому что тип крепления должен быть выбран в соответствии с типом стены. Выберите, пожалуйста, правильные винты к вашей стене.

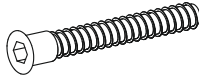
SLO.
POZOR! Pohištvo trajno pritrdite na steno, da preprečite tveganje, da se prevrne. V paketu ni pritrdilnih vijakov, saj je treba način pritrditve ustrezno izbrati glede na vrsto stene. Izberite način, ki je ustrezen za vašo steno.

I.
ATTENZIONE! Il mobile deve essere permanentemente fissato alla parete per evitare i rischi derivanti da un ribaltamento del mobile. La confezione non include le viti di fissaggio, in quanto il tipo di fissaggio deve essere scelto in base al tipo di parete. Utilizzare viti appropriate in base al materiale della parete.

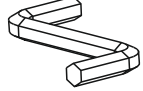
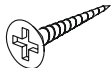
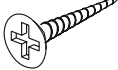
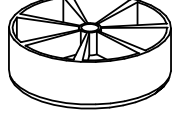
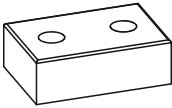

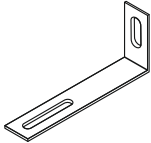
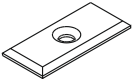
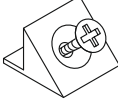
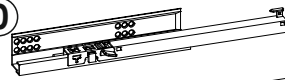
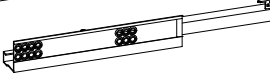
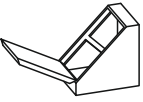
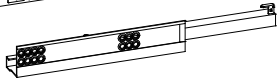
A1	8 x 35 mm	x68	A2	8 x 45 mm	x6	A3	8 x 60 mm	x2
								
C2	5 x 13 mm	x12	E0		x54	E1	15 x 12,5 mm	x54
								
F1	6 x 34 mm	x38	F2	7 x 76 mm	x2	F5	7 x 58 mm	x6
								
G0		x18	G1	7 x 50 mm	x18	I2	4 x 16 mm	x2
								
I5	3,5 x 27 mm	x2	I10	3,5 x 22 mm	x8	M		x1
								
N1	3 x 16 mm	x40	N2	3,5 X 16 mm	x10	O1		x2
								
O3		x4	P26		x3	Q9		x2
								
R1		x14	R4		x17	T10		x3
								
W		x5	Z		x1	L-360		
								

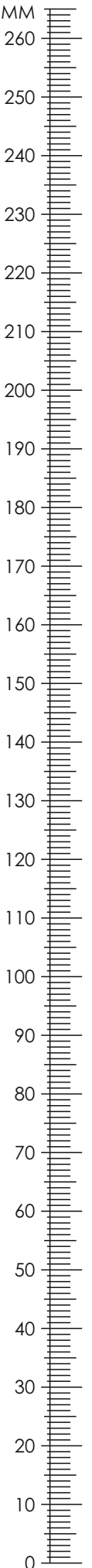

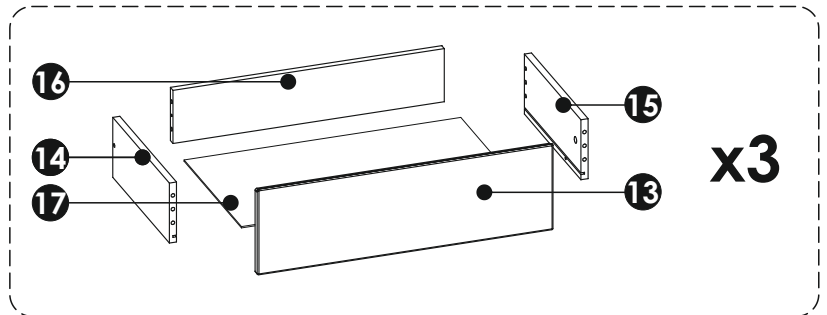
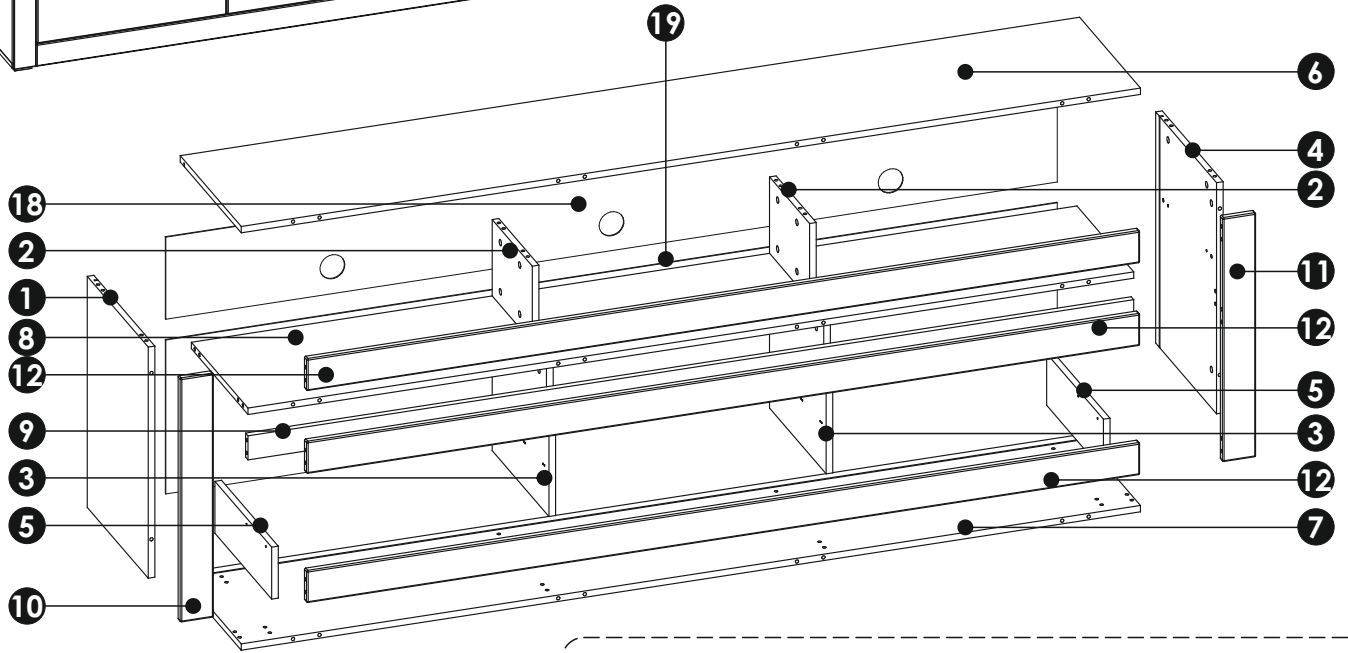
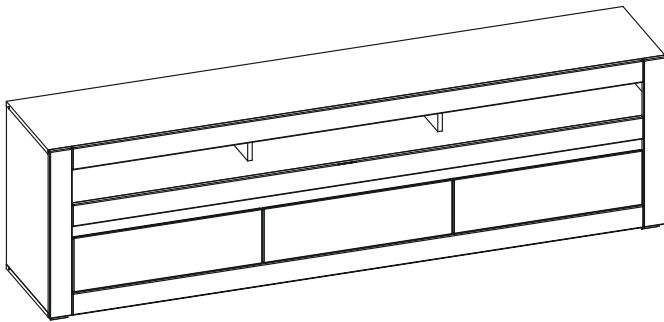

1	578	404	16	x1	1/3
2	191	266	16	x2	1/3
3	371	376	16	x2	1/3
4	578	404	16	x1	1/3
5	130	376	16	x2	1/3
6	2170	404	16	x1	3/3
7	2170	404	16	x1	3/3
8	2137	376	16	x1	2/3
9A	2137	60	16	x1	2/3
9B	2137	60	16	x1	2/3
10	610	80	16	x1	2/3
11	610	80	16	x1	2/3
12	2010	80	16	x3	2/3
13	666	200	16	x3	2/3
14	350	140	16	x3	1/3
15	350	140	16	x3	1/3
16	611	124	16	x3	1/3

17	623	355	3	x3	1/3
18	2151	205	3	x1	3/3
19	2151	385	3	x1	3/3

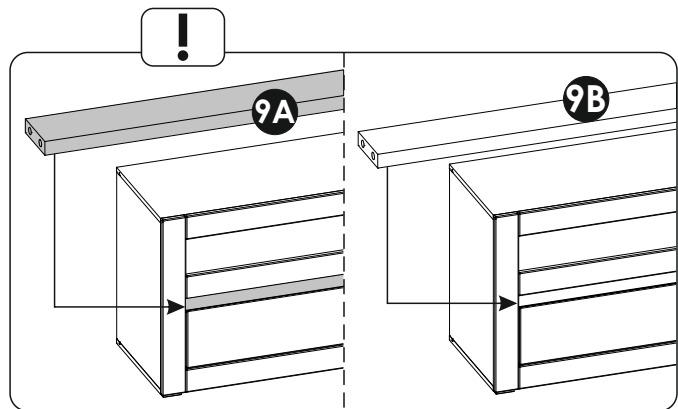

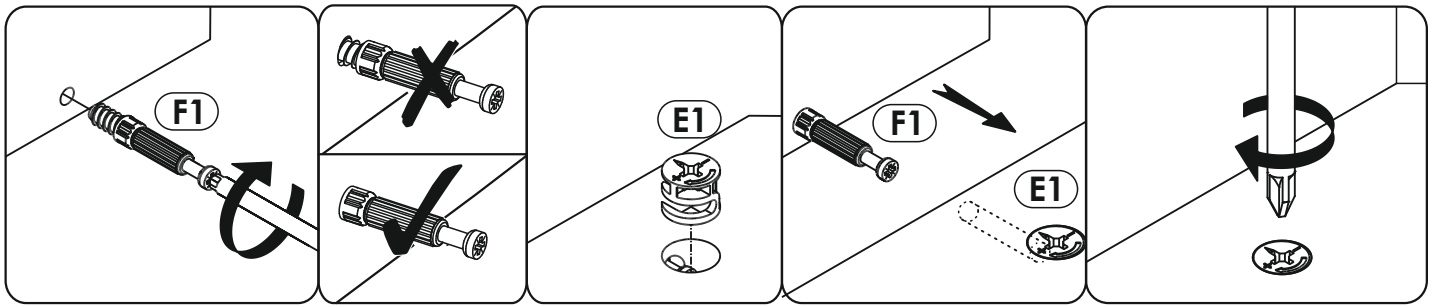

1 ▶

A1	8 x 35 mm	x4	E1	15 x 12,5 mm	x4	F1	6 x 34 mm	x2

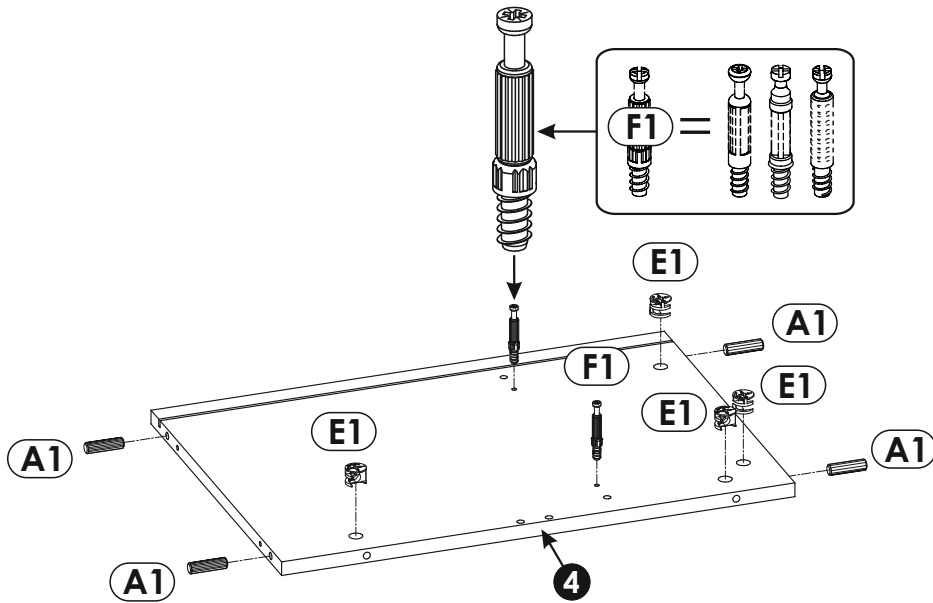

2 ▶

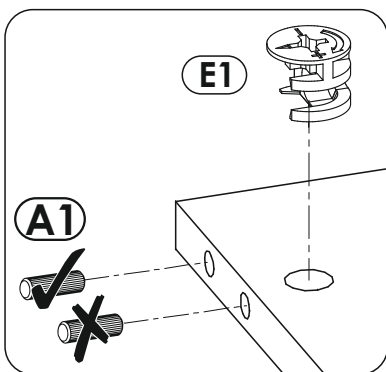

A1	8 x 35 mm	x4	E1	15 x 12,5 mm	x4
F1	6 x 34 mm	x2			

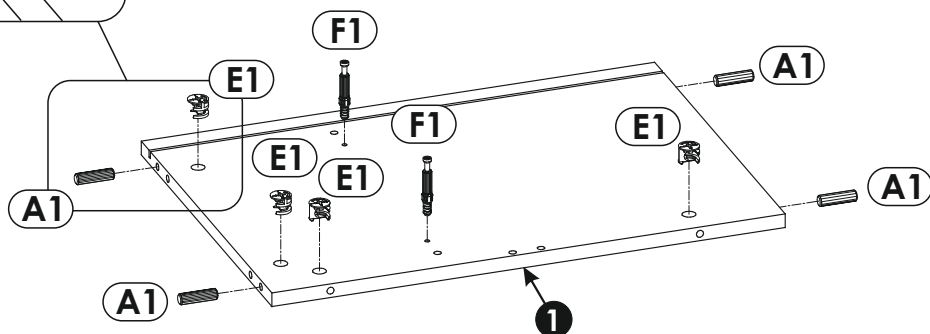

3 ▶

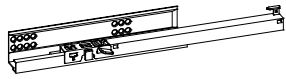
A1	8 x 35 mm	x2	C2	5 x 13 mm	x2	T10		x1
							L-360	

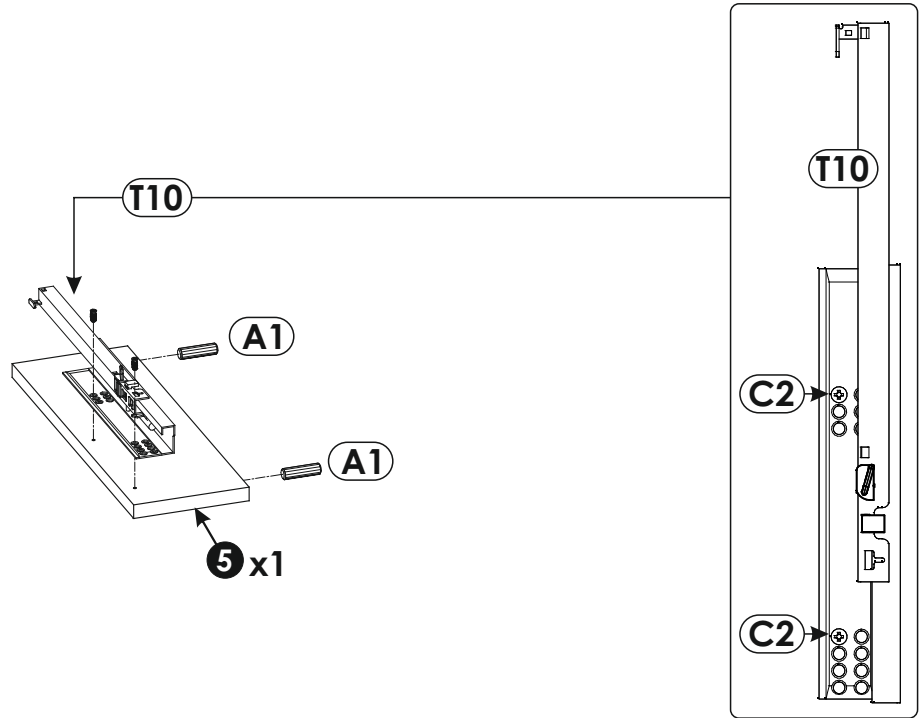

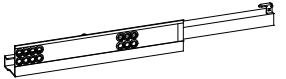

4 ▶

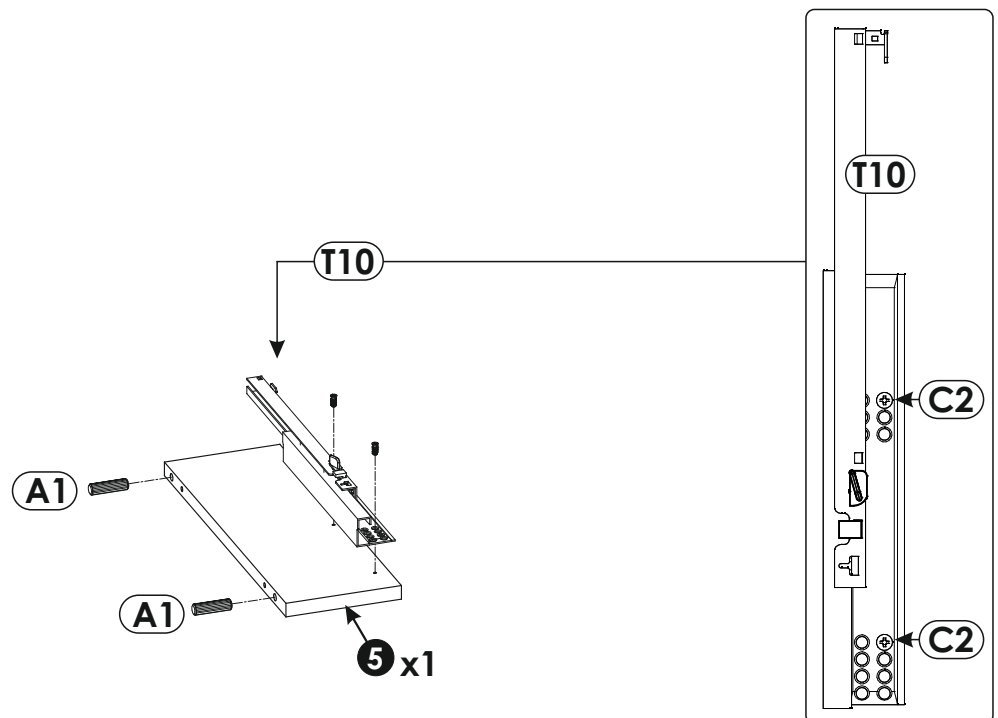
A1	8 x 35 mm	x2	C2	5 x 13 mm	x2	T10		x1
							L-360	



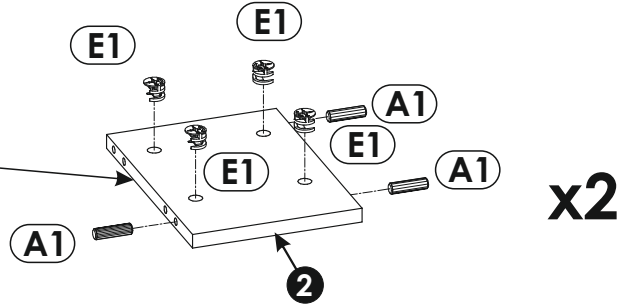
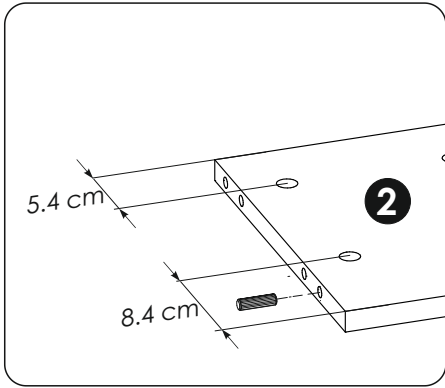

5 ▶

A1 8 x 35 mm x6 	E1 15 x 12,5 mm x8 
---	--

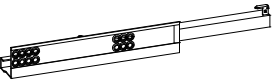

6 ▶

A1 8 x 35 mm x6 	C2 5 x 13 mm x4 	E1 15 x 12,5 mm x4 
T10 x2  L-360		

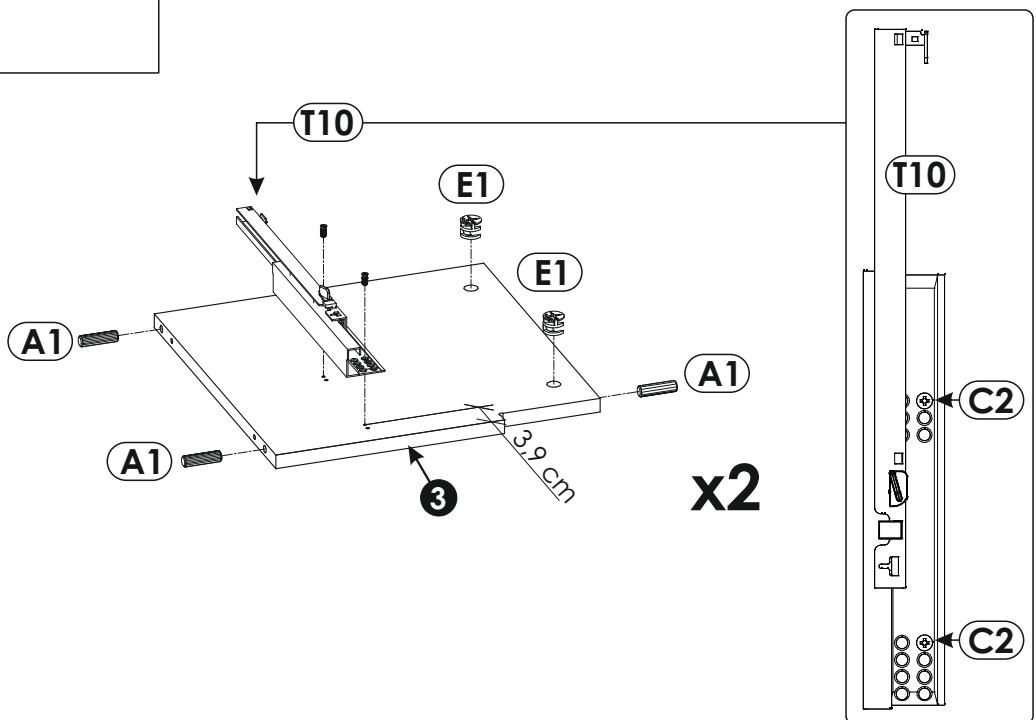

7 ▶

A1	8 x 35 mm	x4	E1	15 x 12,5 mm	x8	F1	6 x 34 mm	x2
-----------	-----------	----	-----------	--------------	----	-----------	-----------	----

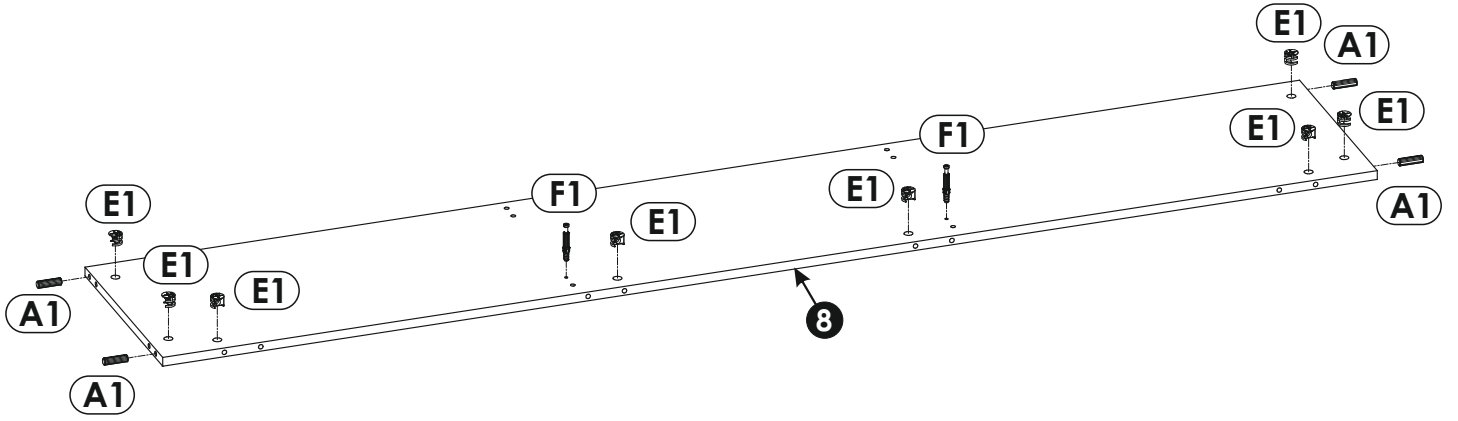

8 ▶

E1	15 x 12,5 mm	x4	F1	6 x 34 mm	x8
-----------	--------------	----	-----------	-----------	----

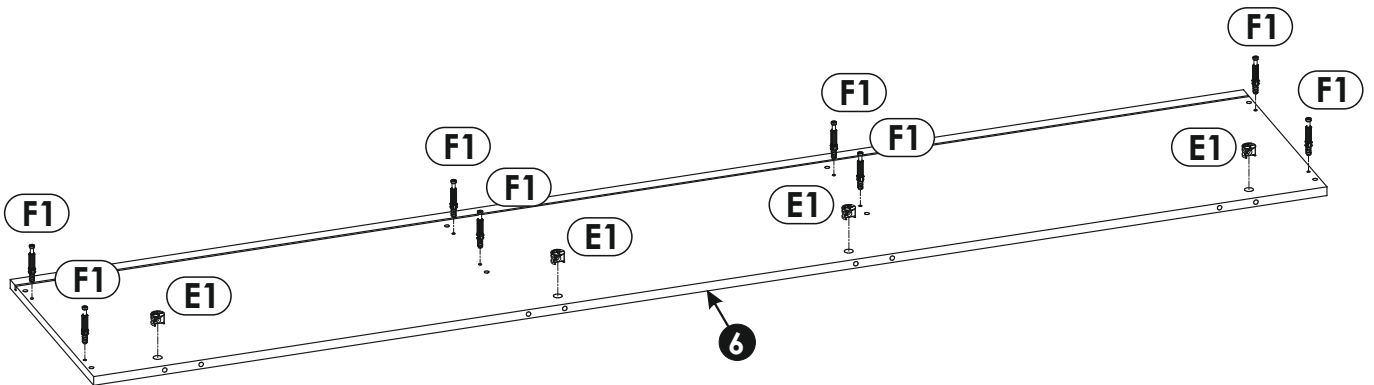

9 ▶

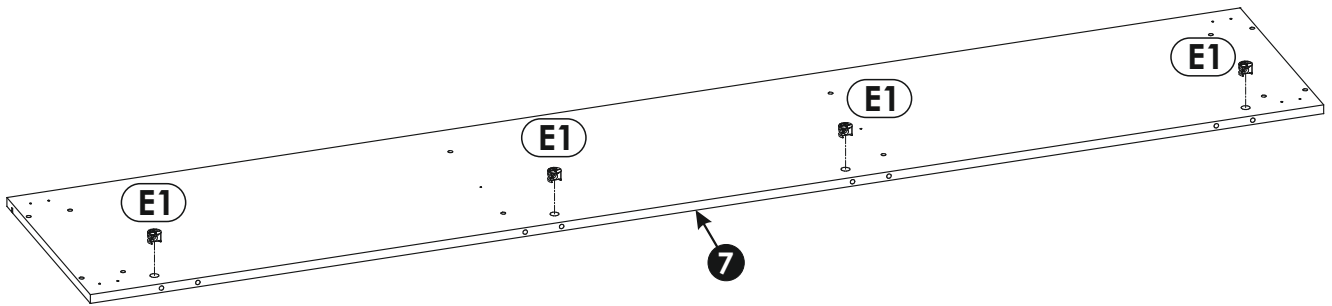
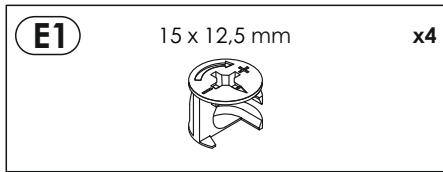

10 ▶

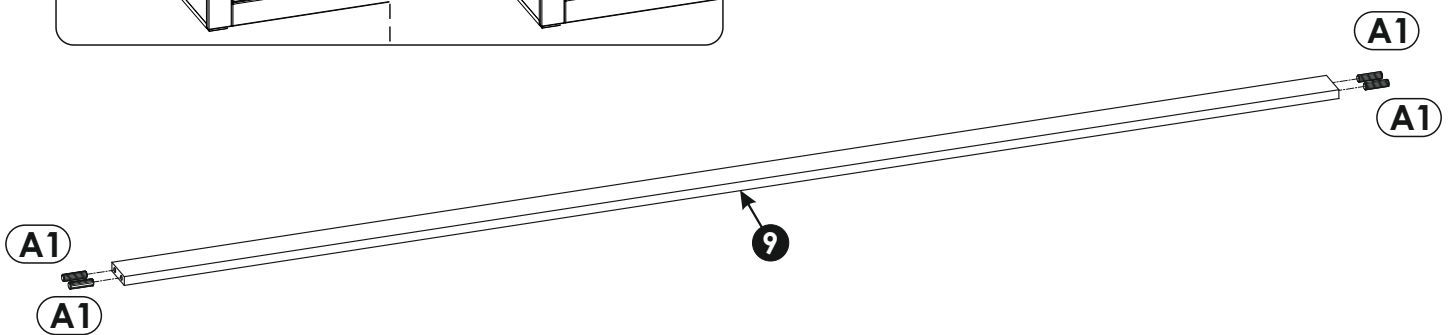
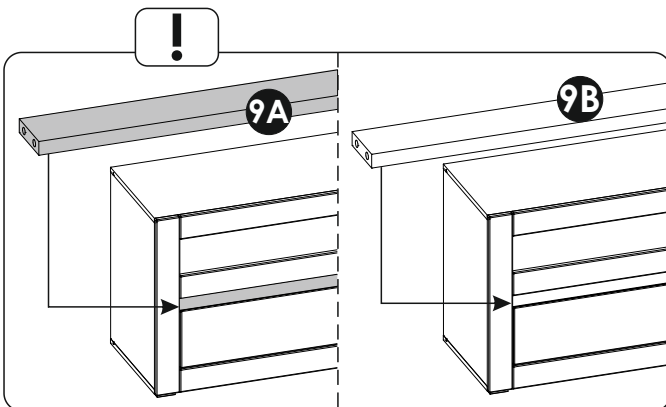
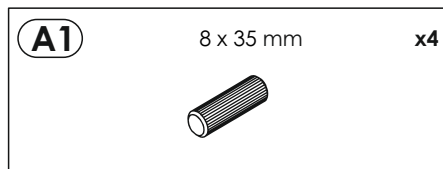

11 ▶

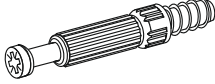
E1	15 x 12,5 mm	x6	F1	6 x 34 mm	x12
					

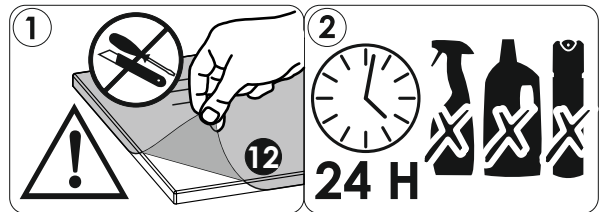
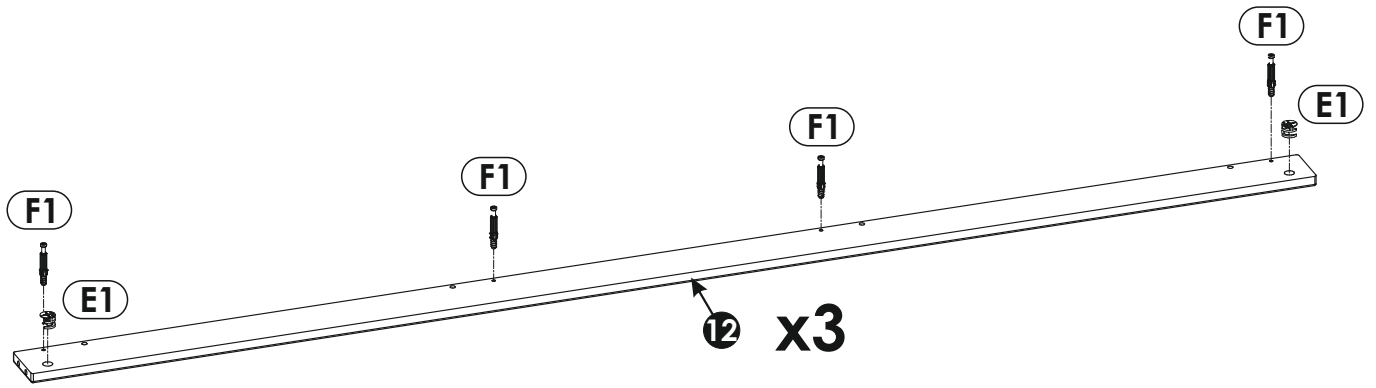



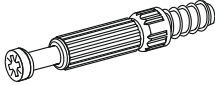

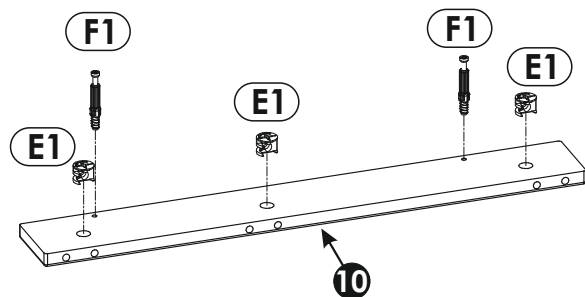
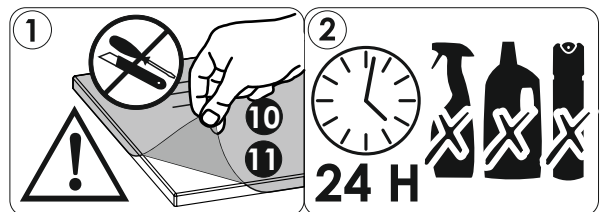
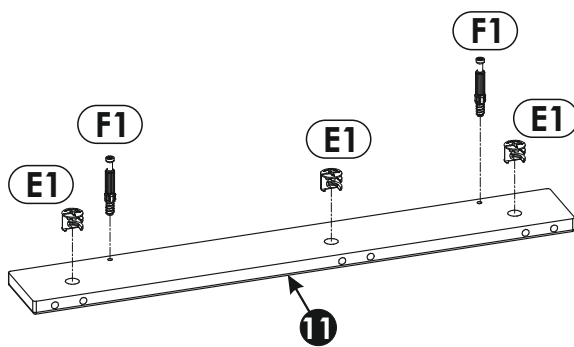
12 ▶

E1	15 x 12,5 mm	x6	F1	6 x 34 mm	x4
					

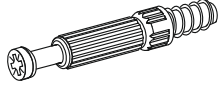

13 ▶

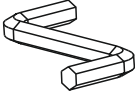
A3 8 x 60 mm x2 	E0  x6	F1 6 x 34 mm x2 
F2 7 x 76 mm x2 	M  x1	

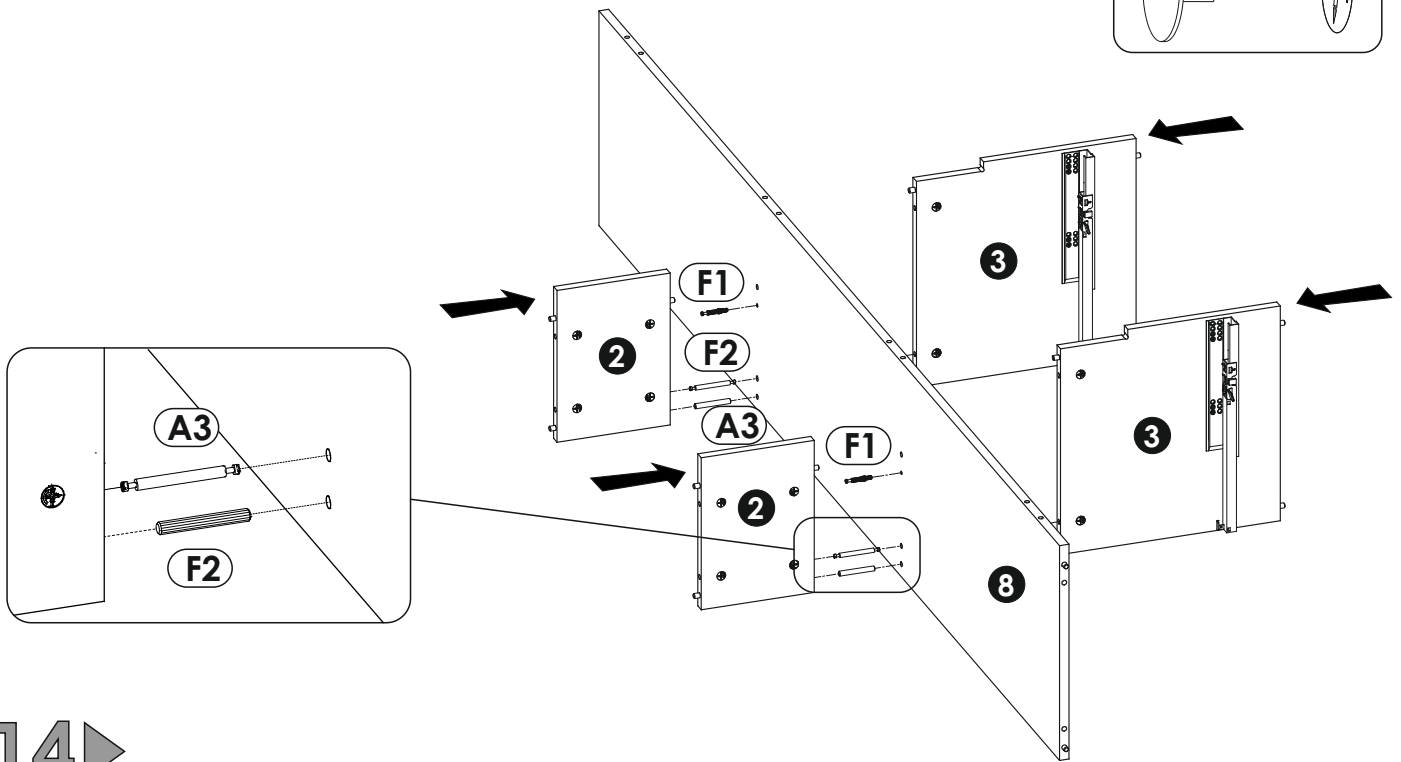
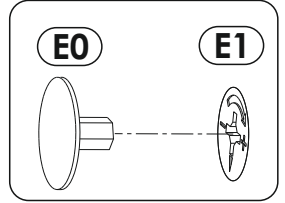

14 ▶

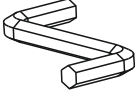
E0  x2	M  x1
--	---

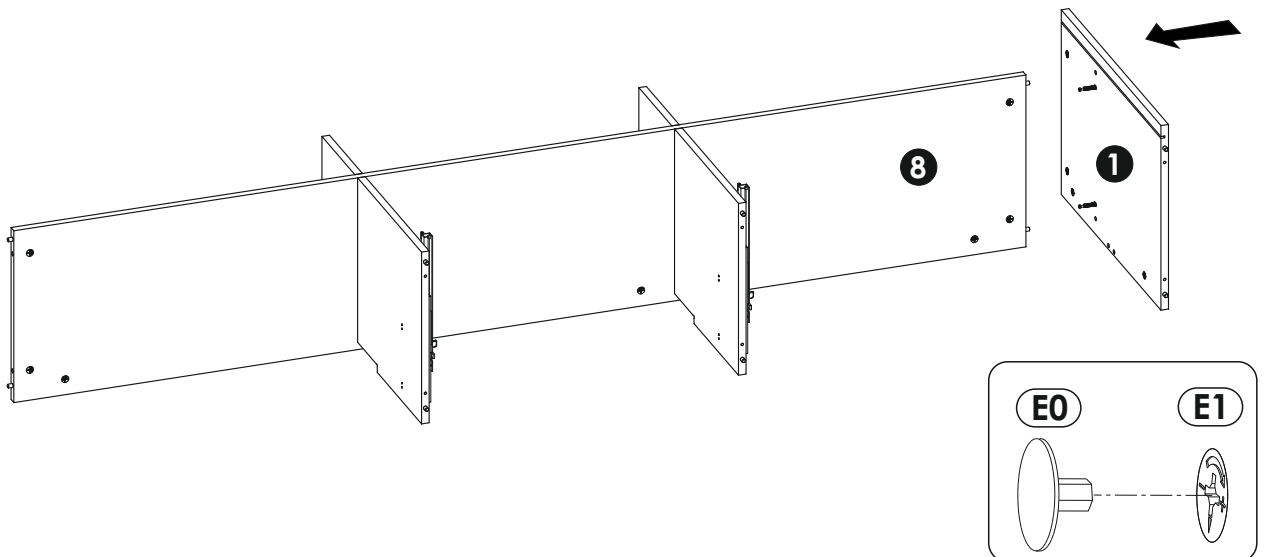

15▶

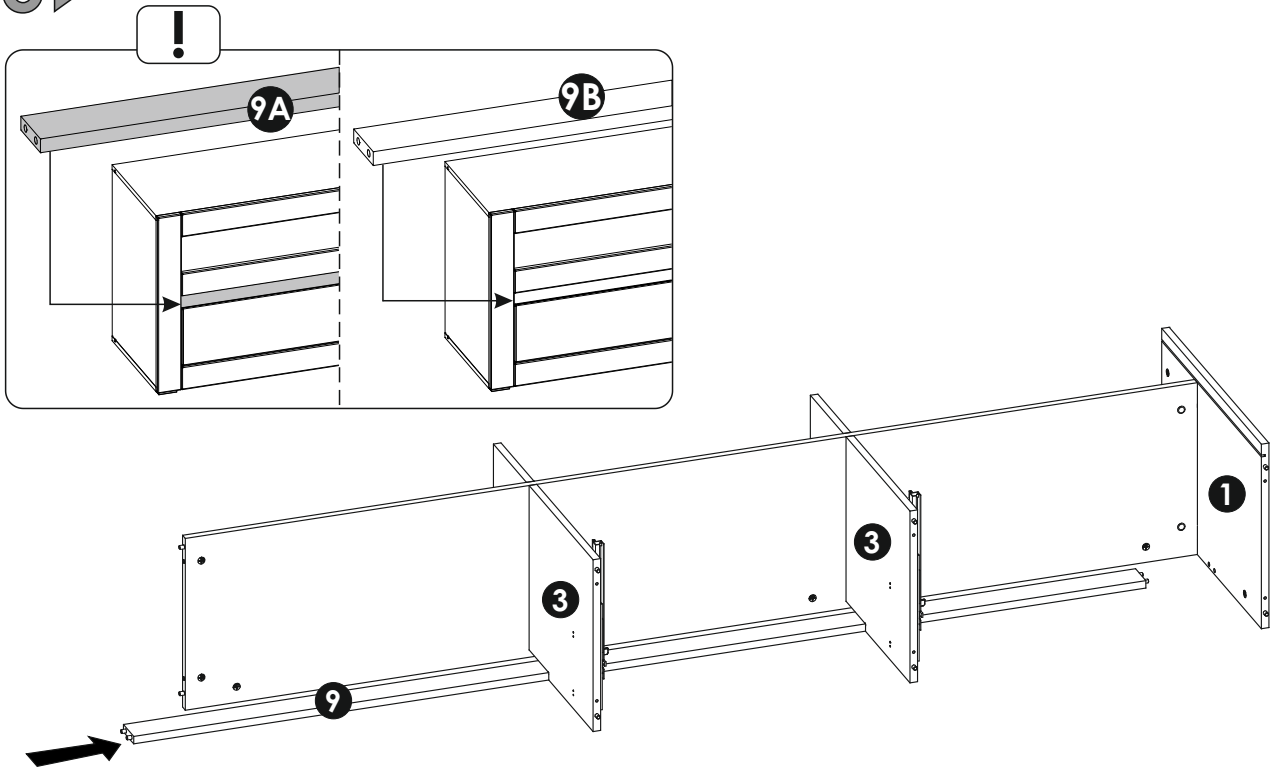

16▶

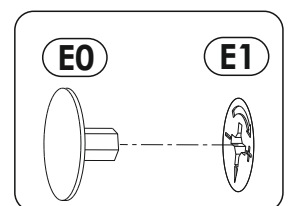
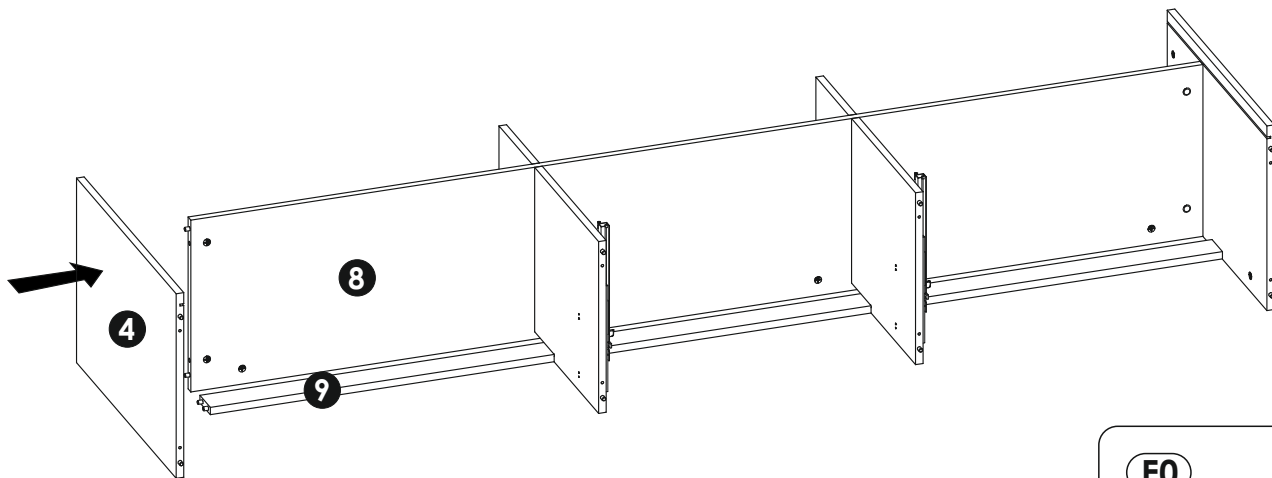
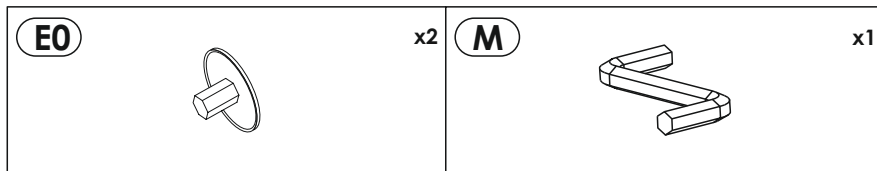

17▶

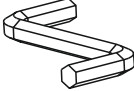
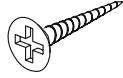
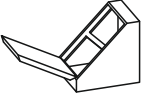

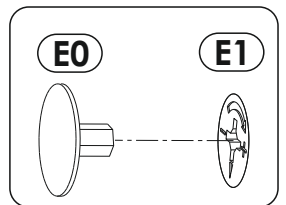
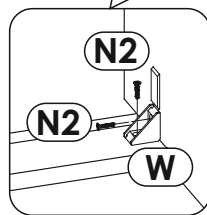
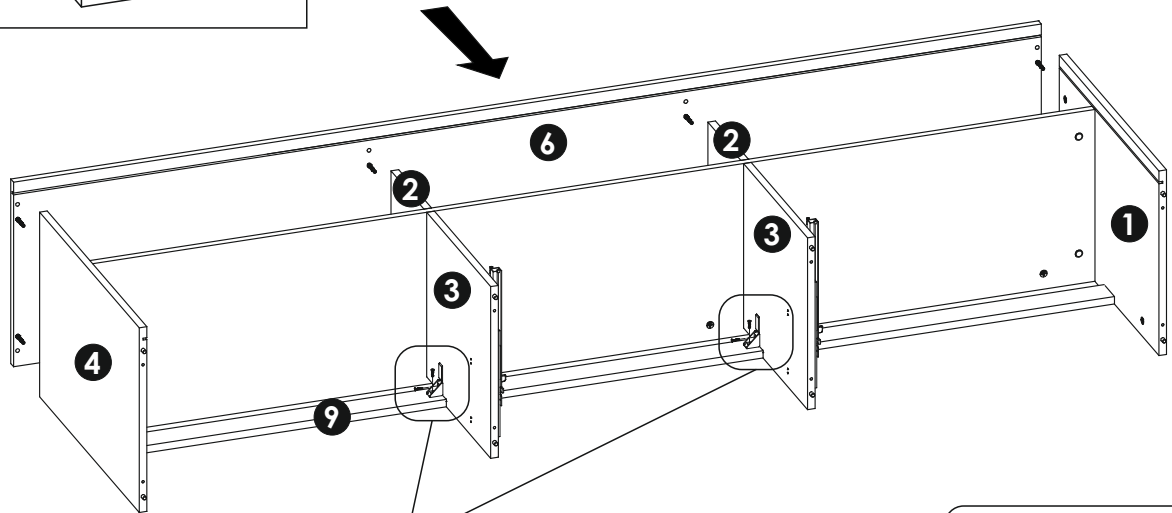
E0 	x8	M 	x1	N2 3,5 X 16 mm 	x4
W 	x2				

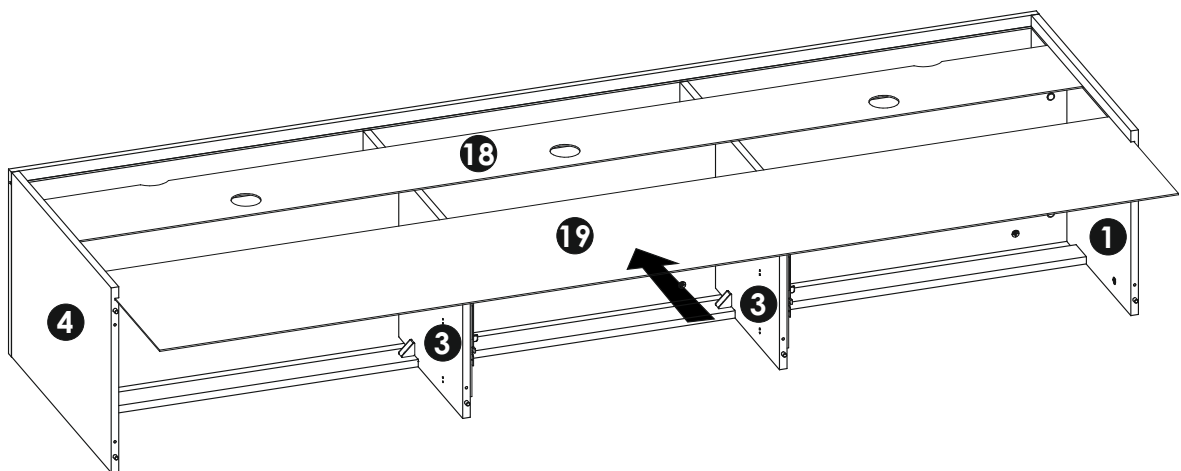

18▶



19 ▶

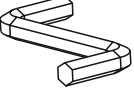

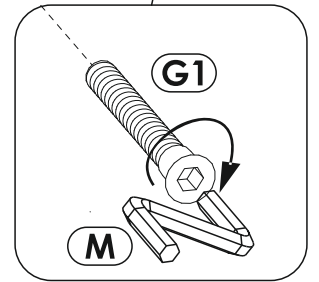
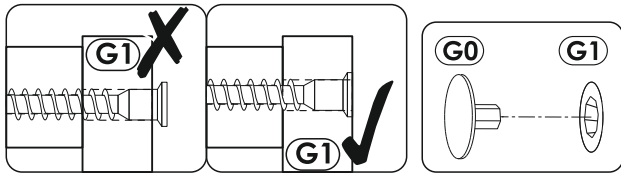
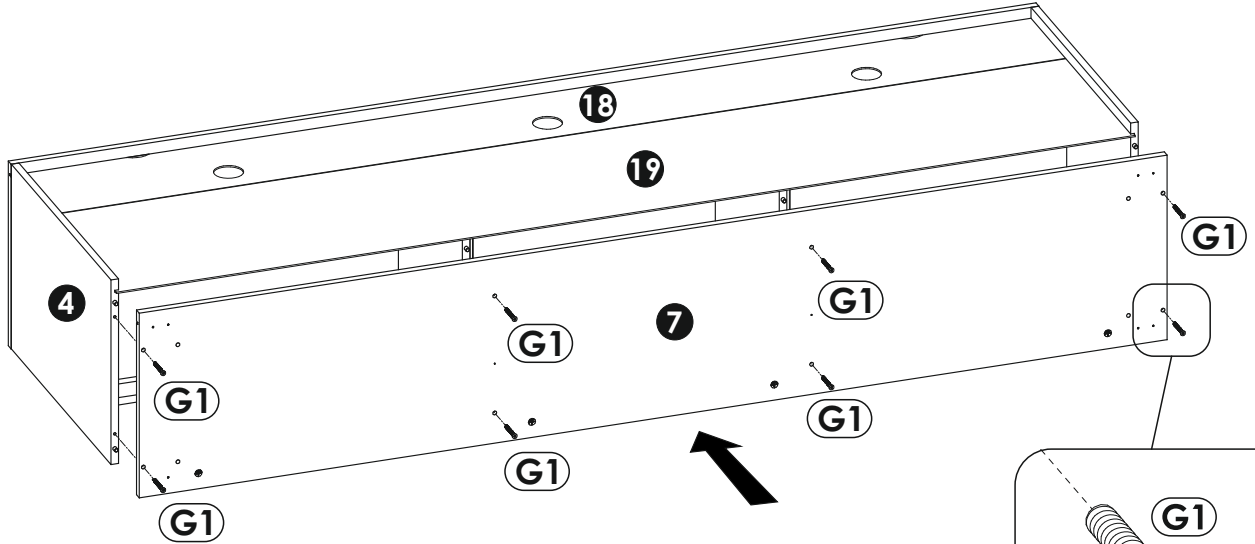

G0  x8	G1 7 x 50 mm  x8	M  x1
--	---	---

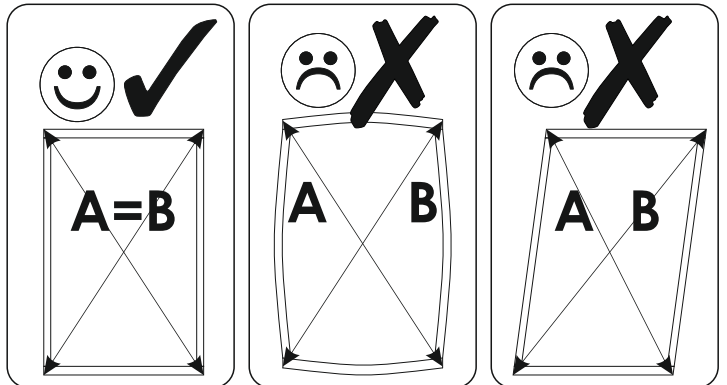
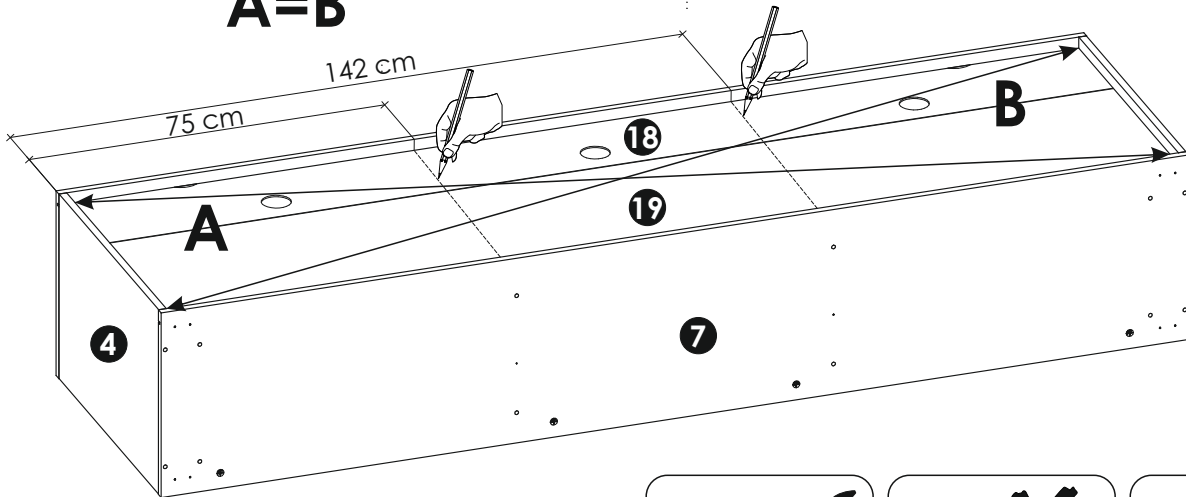

20 ▶

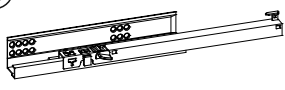

A=B

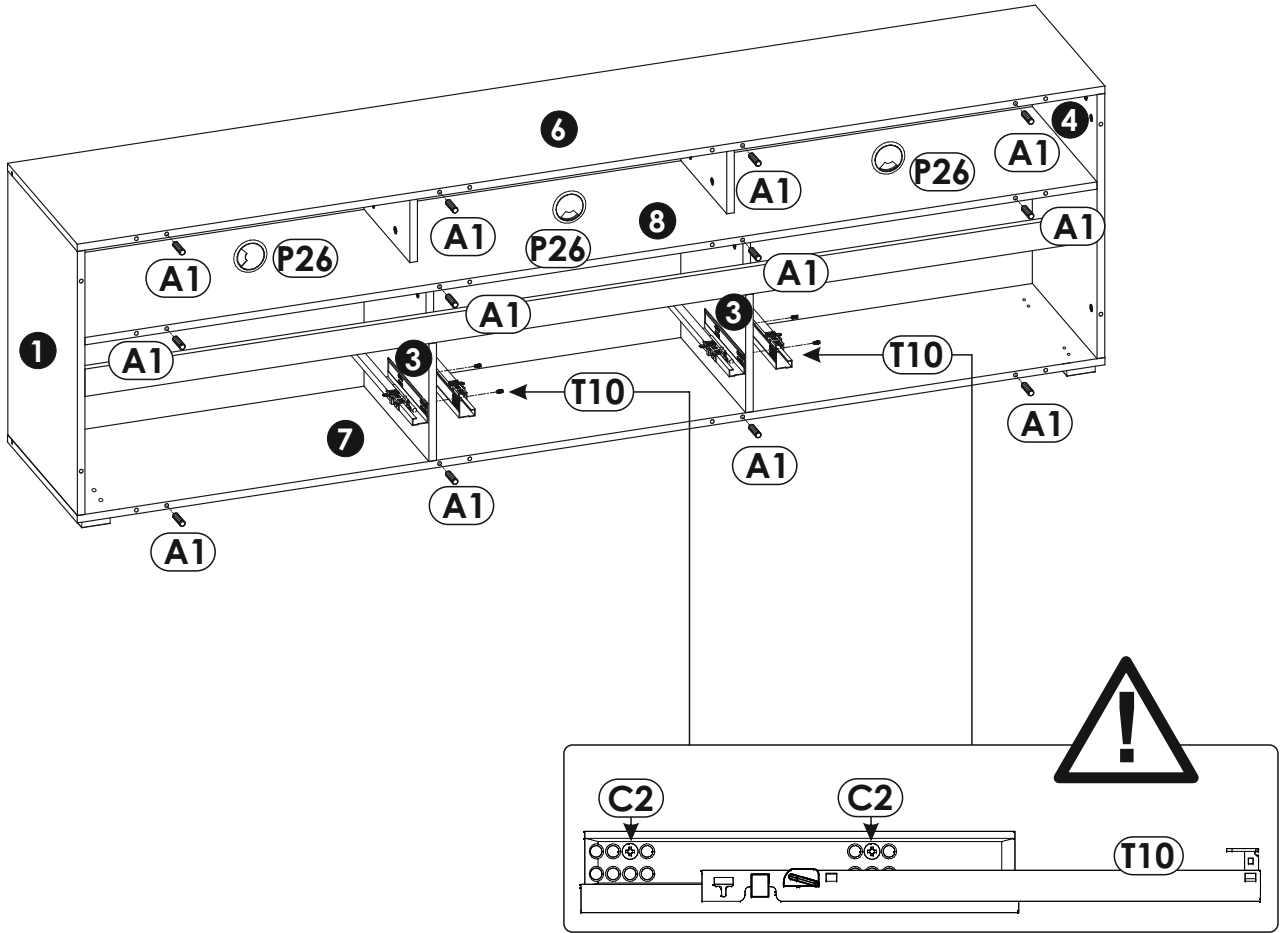
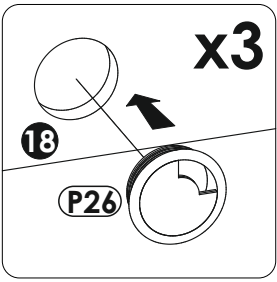

A1 8 x 35 mm x12 	C2 5 x 13 mm x4 	T10 x2  L-360
P26 x3 		

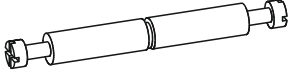
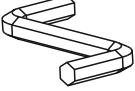

23 ▶

A2 8 x 45 mm x6 	E0 x12 	F5 7 x 58 mm x6 
M x1 		

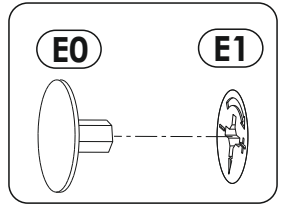
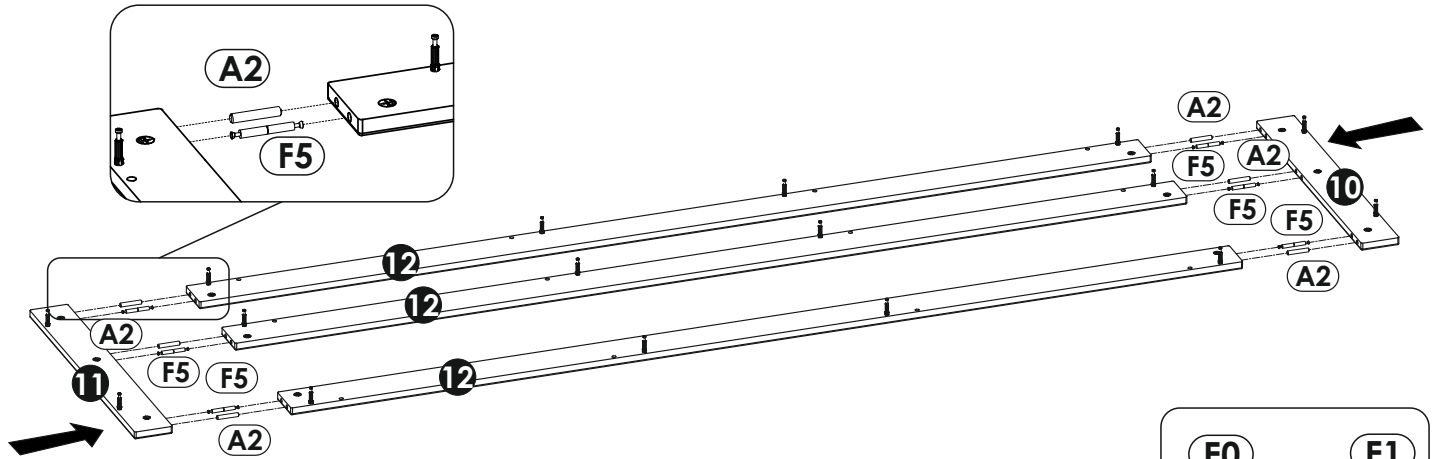

24 ▶

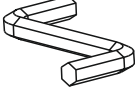
E0 x16 	M x1 
---	---

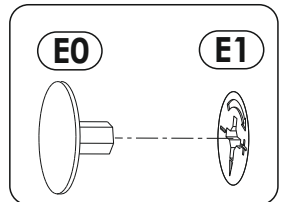
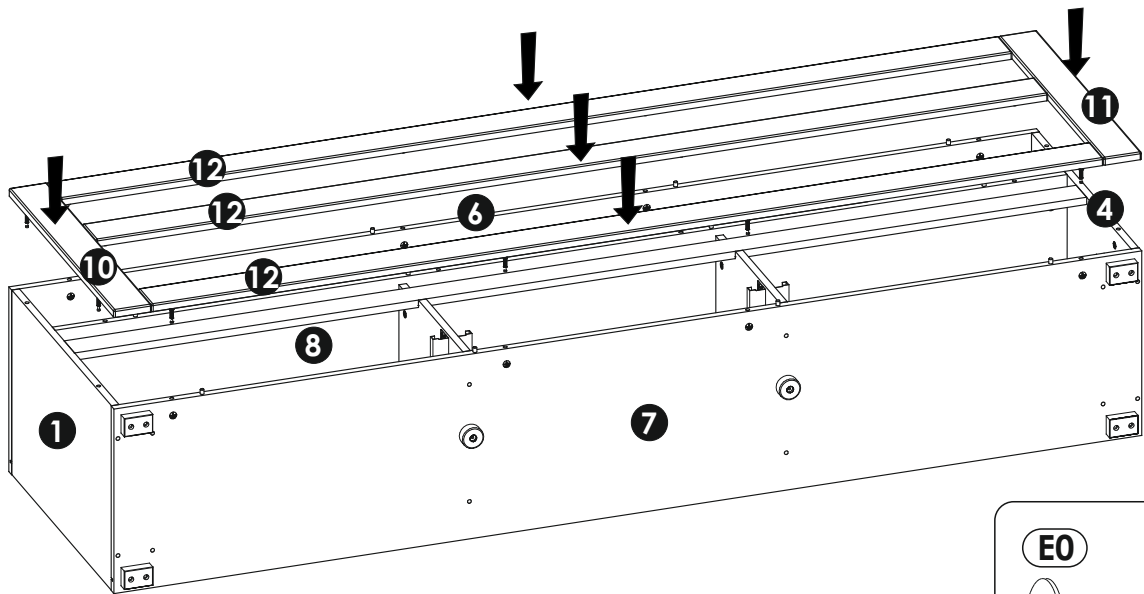

25 ▶

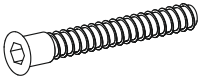
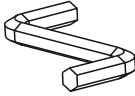
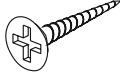
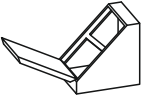
G0  x4	G1 7 x 50 mm  x4	M  x1
N2 3,5 X 16 mm  x6	W  x3	

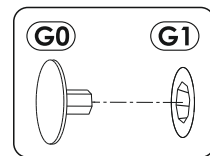
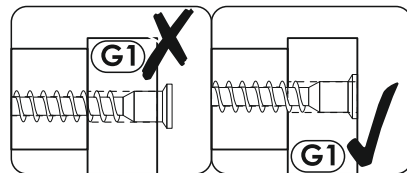
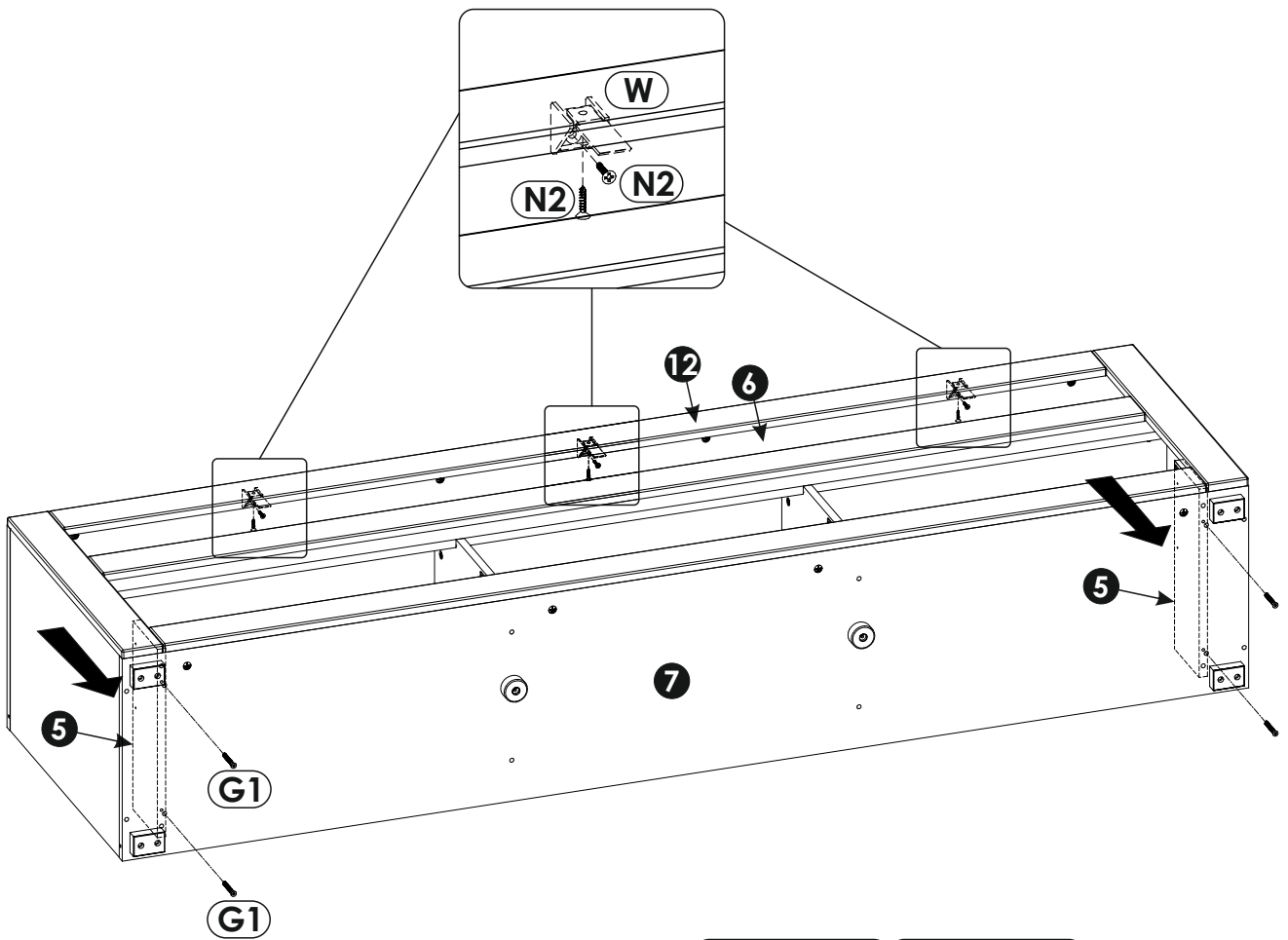

I2	4 x 16 mm	x2
Q9		x2
Z		x1

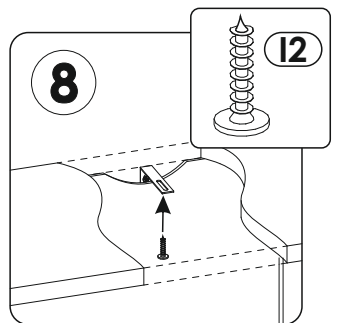
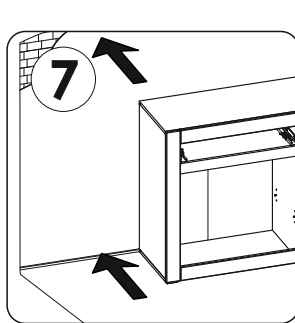
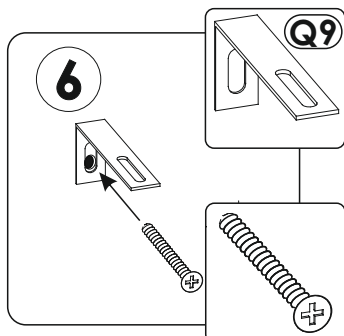
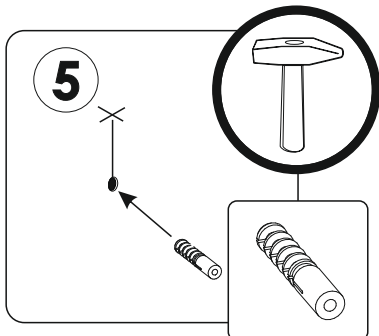
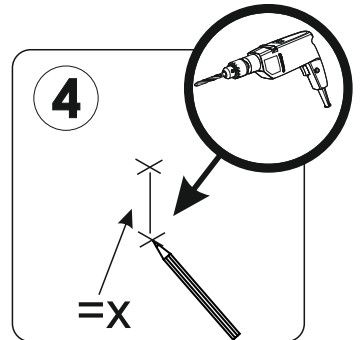
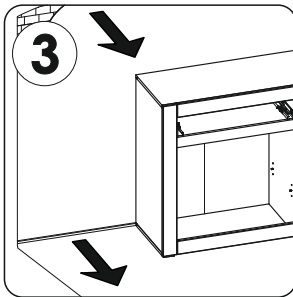
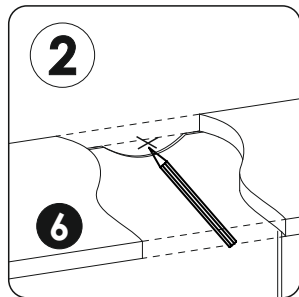
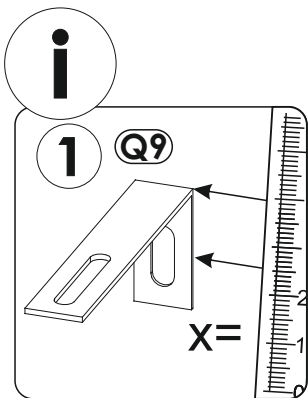
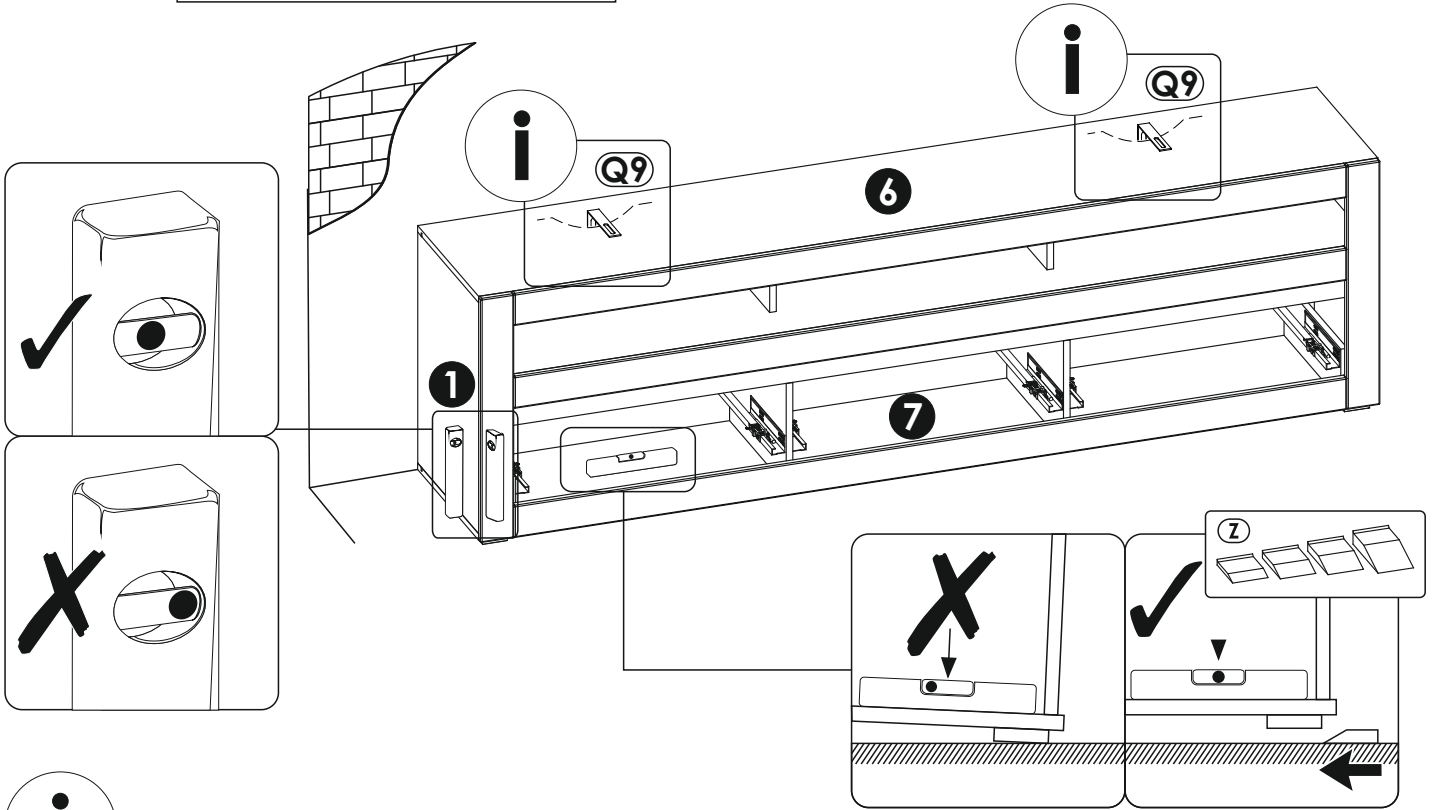
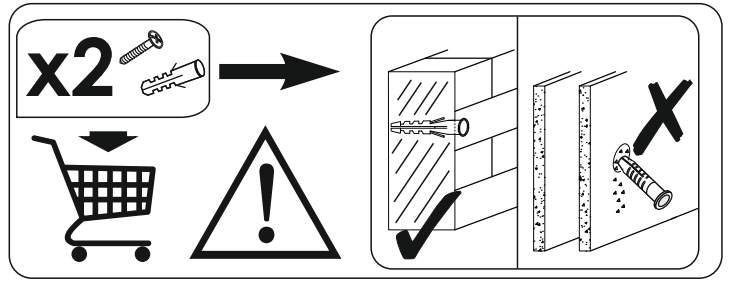

27▶

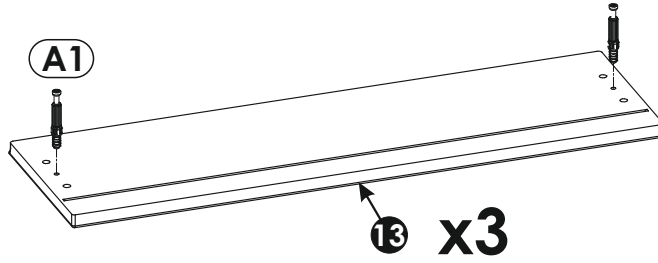
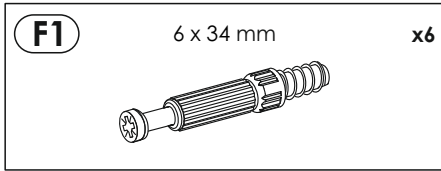

28▶

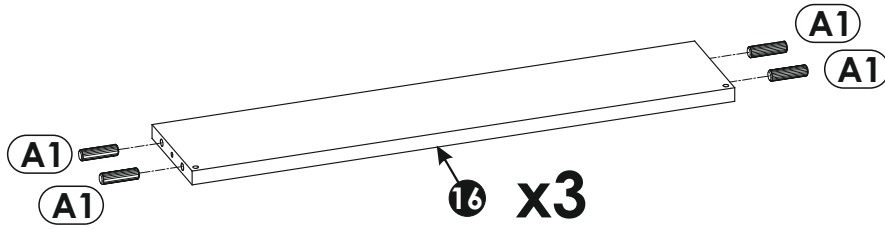
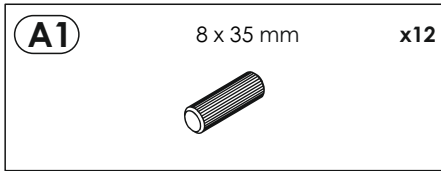

29▶

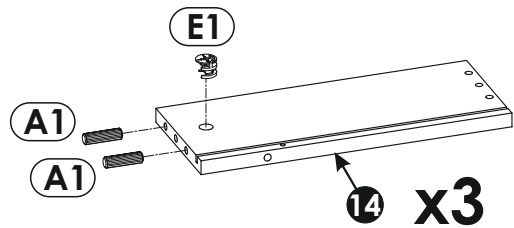
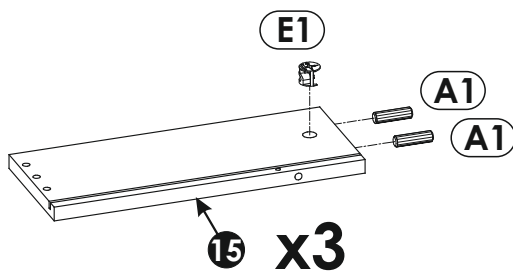
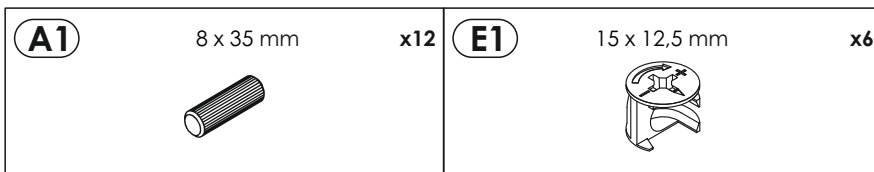

30 ▶

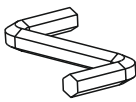
G0		x6	G1	7 x 50 mm	x6	M		x1
-----------	---	----	-----------	-----------	----	----------	---	----

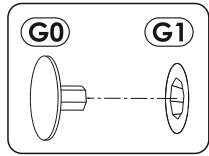

x3

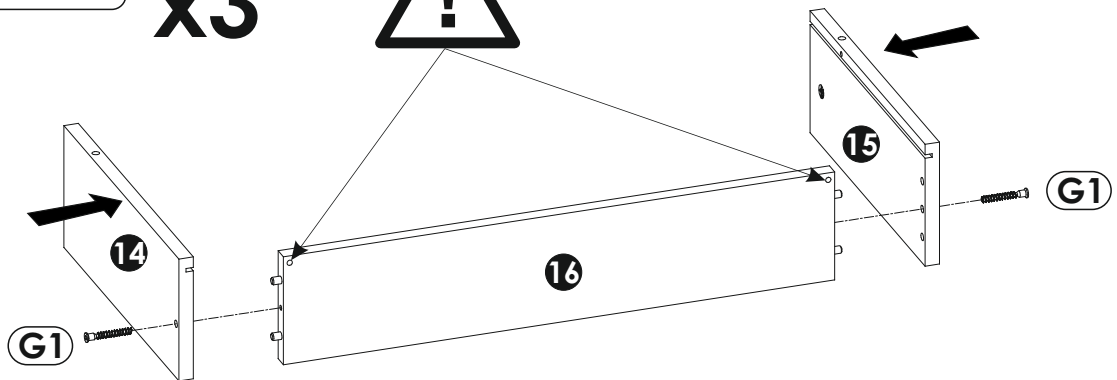

31 ▶

E0		x6	M		x1
-----------	---	----	----------	--	----

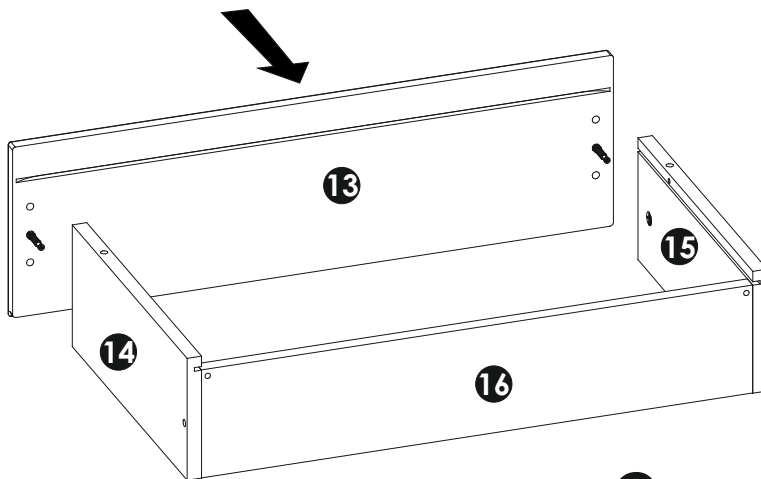

x3

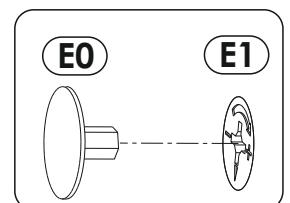

32 ▶

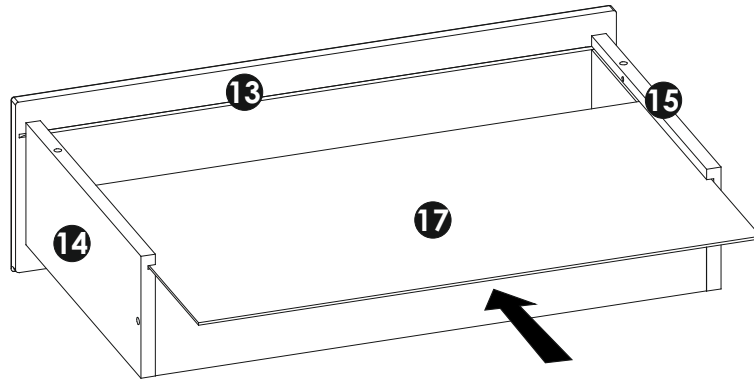

x3

33 ▶

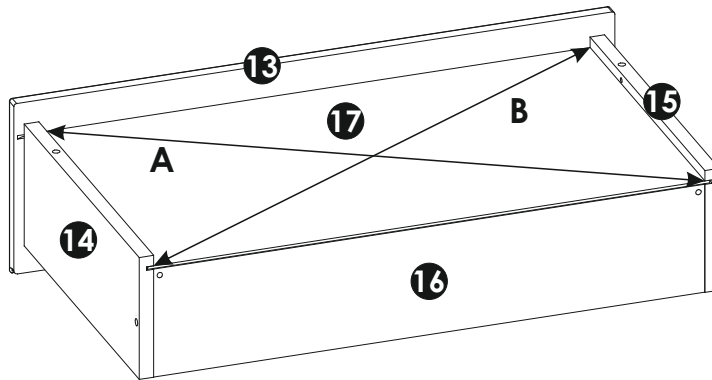

A=B

x3

34 ▶

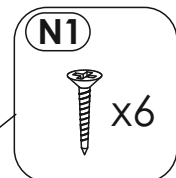
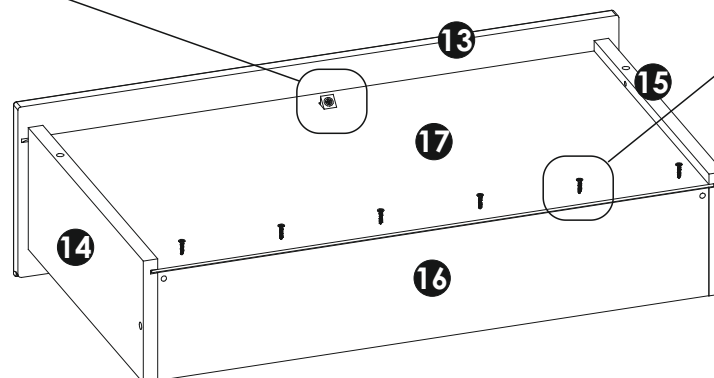
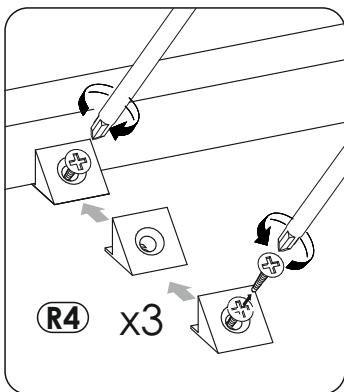
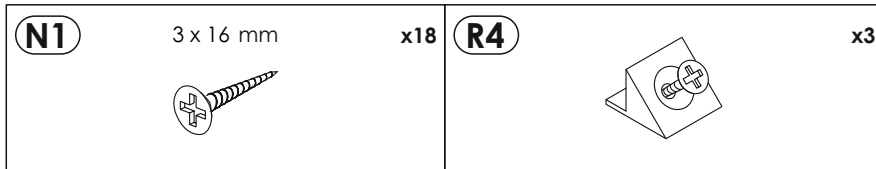

x3

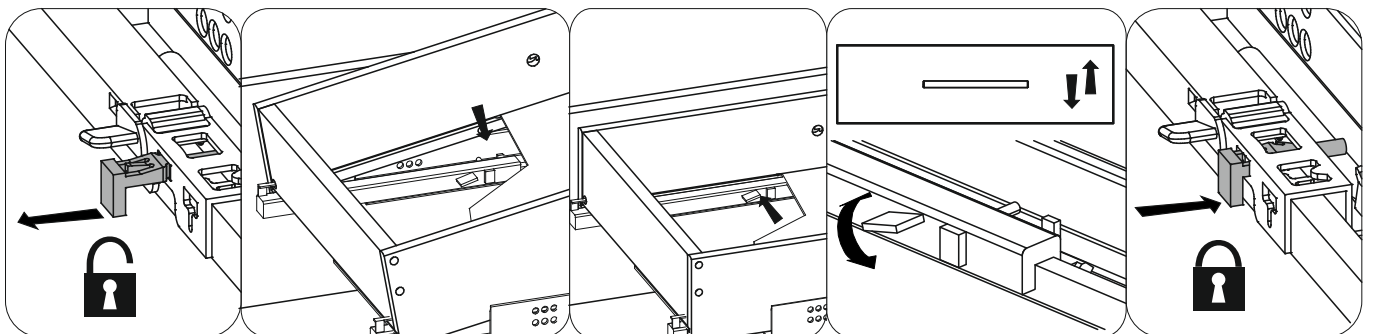
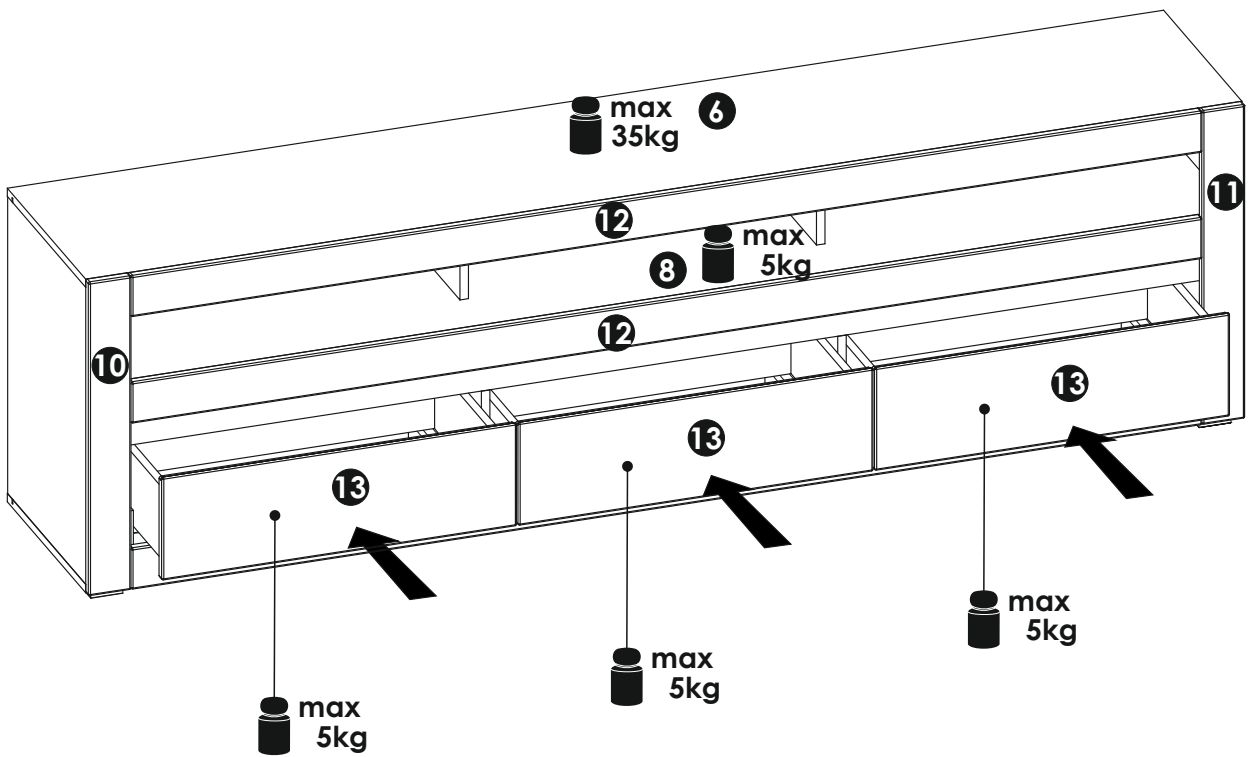
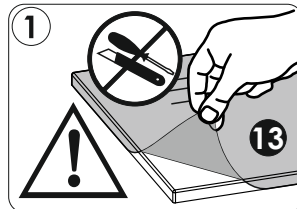

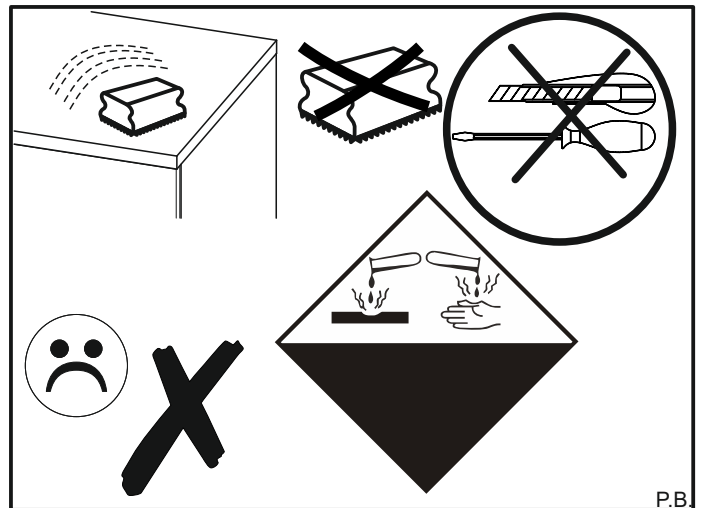
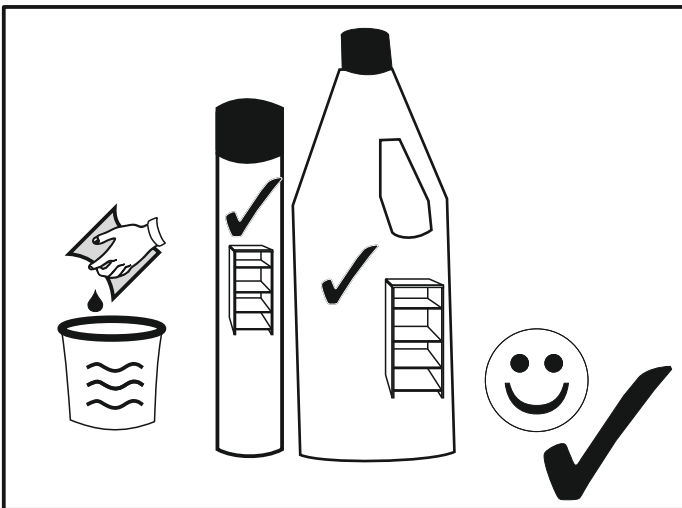
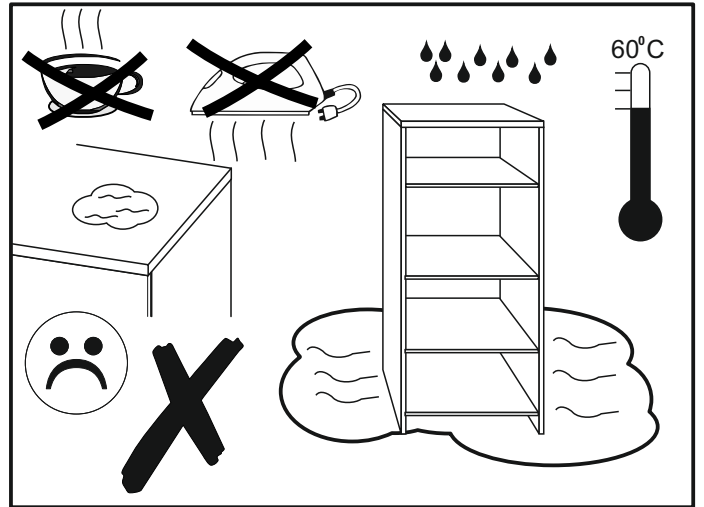
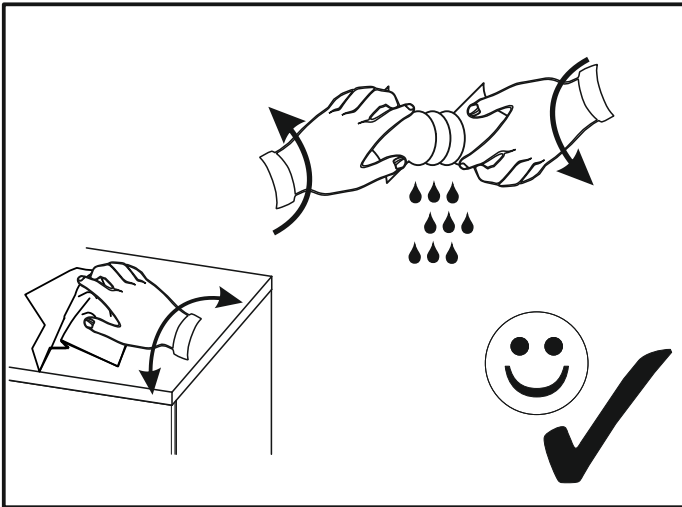
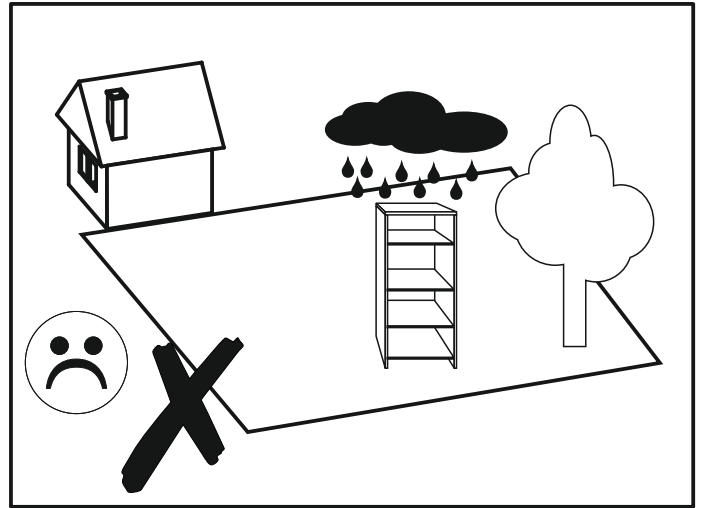
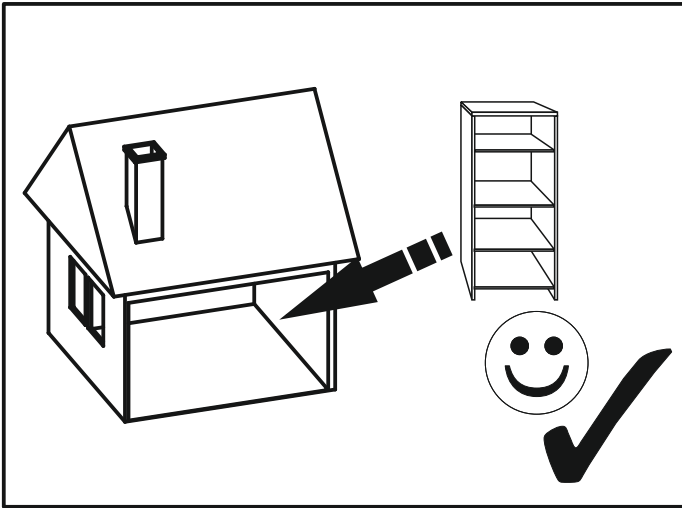



Pflegehinweis für Möbel-Hochglanzfronten



Wskazówki dotyczące pielęgnacji mebli na wysoki połysk



Onderhoudstip voor hoogglanzende voorkanten van meubelen



Care instructions for high-gloss surfaces of furniture



İnce cilalı yüzler için bakım talimatı



Указания по уходу за гляцевыми поверхностями мебели



Consigli di manutenzione per facciate lucide di mobili



Consigne d'entretien pour les faces de meubles de haute brillance



Instrucțiuni de întreținere pentru fețe lucioase de mobilier



Pokyn pre ošetrovanie leštených čelných plôch nábytku



Informace pro péči o nábytková čela s vysokým leskem



Ápolási tanácsok a bútorok fényes homlokzati felületeihez



Attention! Notice!

Our high gloss surfaces have a protective foil when delivered. Please leave this foil on the furniture until it is completely assembled and all dust has been removed.

- To maintain the valuable high gloss appearance, you should
- expose the high gloss foil to the room air for an hour to allow it to harden after removing the protective foil.
 - only use a damp cotton cloth and a small amount of glass cleaner to clean the surfaces.
 - Do not use any aggressive cleaners with additives.
 - Rub off the surfaces with a wet rag.
 - Do not use a steam cleaner.
 - Do not damage the surface with sharp objects.
 - Do not in any case expose the surfaces to intense sunlight.

We wish you plenty of enjoyment with your new furniture.

Your product development team



Upozornenie!

Leštené plochy sú pri dodaní chránené ochrannou fóliou. Túto fóliu neodstraňujte skôr, ako nábytok zmontujete a zbavíte prachu.

Aby ste zachovali vzhľad lešteného povrchu, mali by ste

- leštenú fóliu po odstránení ochrannej fólie nechať na vzduchu približne jednu hodinu zatvrdnúť,
- pre čistenie povrchu používať len vlhkú bavlnenú utierku a malé množstvo umývacieho prostriedku na sklá.
 - Nepoužívajte žiadny ostrý čistiaci prostriedok s prídavnými látkami.
 - Povrchy vydrhnite mokrú handrou.
 - Nepoužívajte parný čistič.
- Povrchy nepoškodzujte ostrými predmetmi.
- Povrchy v žiadnom prípade nevystavujte silnému slnečnému žiareniu.

Želáme vám veľa radosti s vašim novým nábytkom.

Váš vývoj výrobku



Attention Remarque !

Nos surfaces haute brillance sont protégées à la livraison par un film protecteur. Veuillez le laisser sur le meuble jusqu'à ce qu'il soit entièrement installé et que la poussière soit supprimée.

Pour obtenir un aspect de qualité et de haute brillance, vous devez

- laisser durcir pendant une heure à l'air ambiant le film haute brillance après avoir enlevé le film protecteur
- pour le nettoyage des surfaces, utiliser uniquement un chiffon de coton humide et un peu de lave-vitre.
 - Ne pas utiliser de détergent agressif comportant des additifs.
 - Frotter les surfaces avec un chiffon humide.
 - Ne pas utiliser de nettoyeur à vapeur.
- ne pas endommager la surface avec des objets coupants
- ne pas soumettre les surfaces à un fort rayonnement solaire

Nous souhaitons que votre nouveau meuble vous donne entière satisfaction.

Votre service de développement de produits



Atenție indicație!

Suprafețele noastre lucioase sunt protejate la livrare cu o folie de protecție. Păstrați-o pe mobilier până la realizarea completă a montajului, respectiv până când nu se mai degajă praf.

Pentru a menține aspectul unic de luciu intens, trebuie să

- dup ă îndepărtarea foliei de protecție, asigurați aerisirea foliei lucioase pentru călire timp de o oră,
- utilizați pentru curățarea suprafețelor exclusiv o cârpă din bambac umezită și puțină soluție de curățat sticlă.
 - nu utilizați detergenți corosivi cu aditivi,
 - ștergeți suprafețele cu o cârpă umedă,
 - nu utilizați dispozitive de curățat cu abur.
- Nu deteriorați suprafețele cu obiecte ascuțite
- Nu expuneți în niciun caz suprafețele la radiații solare intense

Vă dorim multe satisfacții la utilizarea noului dvs. mobilier.

Departamentul dvs. de creație produse



Figyelem, olvassa el a tanácsot!

A fényes felületeket a kiszállítás során védőfóliával védjük. Hagyja a fóliát a bútoron addig, amíg azt teljesen össze nem szerelte és nem távolította el róla a port.

Az értékes fényes felület megóvásához tegye a következőket:

- Hagyja a fényes fóliát a védőfólia eltávolítása után egy órát keményedni a helyiség levegőjében.
- A felületek tisztításához kizárólag nedves pamutkendőt és egy kevés ablaktisztítót használjon.
 - Ne használjon éles szemesítés tisztítószereket.
 - A felületet törölje át egy nedves ronggyal.
 - Ne használjon gőzölős tisztítóeszközt.
- A felületet óvja a kemény tárgyakkal való sérüléstől.
- A felület mindig óvni kell az erős napsütéstől.

Reméljük, sok örömet lel az új bútor használatában.

A termékfejlesztők



Pozor upozornění!

Naše povrchy s vysokým leskem jsou při dodání chráněny ochrannou fólií. Ponechte ji na nábytku, dokud nebude kompletně smontovaný a nebude z něho odstraněný prach.

Aby se zachovala cenná optika vysokého lesku, měli byste:

- dát vysoce lesklé fólii po odstránení ochranné fólie hodinu čas na vytvrzení na pokojovém vzduchu,
- pro čištění povrchů používejte pouze vlhký bavlněný hadřík a trochu čisticího prostředku na skla.
 - nepoužívejte ostrý čističí prostředek s přísadami,
 - povrchy otírejte mokrou hadrou,
 - nepoužívejte parní čističí.
- nepoškoďte povrch ostrými předměty
- povrchy v žádném případě nevystavujte silnému slunečnímu záření

Přejeme Vám hodně radosti s Vaším novým nábytkem.

Vaše oddělení vývoje nových výrobků



Uwaga informacja!

Nasze powierzchnie o wysokim połysku są fabrycznie ochronione specjalną folią ochronną. Prosimy pozostawić ją na meblach do momentu zmontowania i usunięcia kurzu.

Aby utrzymać wysoki połysk, należy

- po usunięciu folii ochronnej pozostawić folię polyskową przez godzinę w pomieszczeniu do stwardnienia
- stosować do czyszczenia wyłącznie bawełnianą szmatkę i odrobinę środka do mycia szkła
 - nie stosować ostrych środków czyszczących z dodatkami
 - ścierać powierzchnie wilgotną szmatką
 - nie stosować myjki parowej
- Nie uszkodzić powierzchni ostrymi przedmiotami.
- W żadnym wypadku nie narażać powierzchni na mocne promieniowanie słoneczne.

Życzymy przyjemnego użytkowania i zadowolenia z nowych mebli.

Dział Rozwoju Produktu



Dikkat, Bilgilendirme!

Yüksek parlaklıktaki yüzeyleriniz teslimat esnasında bir koruma folyosu ile korunmaktadır. Mobilyalar tamamen monte edilip tozdan arındırıldıktan sonra folyoyu üzerinize bırakınız.

Değerli yüksek parlak görünümlünüzü korumak için

- yüksek parlaklıktaki folyoya koruma folyosu çıkarıldıktan sonra oda havasında sertleşmesi için bir saatlik bir zaman tanıyınız.
- Yüzeylerin temizli için işi sadece nemli pamuk bez ile biraz cam temizleyici kullanınız.
 - Ek maddeler içereren keskin temizlik malzemeleri kullanmayınız.
 - Yüzeyleri şlak bir bezle ovunuz.
 - Buharlı temizleyici kullanmayınız.
- Yüzeye keskin aletlerle zarar vermeyiniz.
- Yüzeyi hiçbir surette güçlü güneş ışınlarına maruz bırakmayınız.

Yeni mobilyanızla sevinç duymanız dileği.

Ürün Geliştirme Departmanı



Attenzione!

Al momento della consegna, le nostre brillanti superfici sono protette da una pellicola. Lasciarla sul mobile finché non sarà completamente montato e spolverato.

Per conservare il pregiato aspetto brillante, osservare i seguenti consigli:

- consentire alla pellicola lucida di adattarsi per un'ora al clima dell'ambiente dopo aver tolto la pellicola protettiva,
- pulire le superfici usando solo un panno di cotone umido e un po' di detersivo per vetri.
 - Non utilizzare detersivi aggressivi con additivi.
 - Pulire le superfici passando solo strofinaccio bagnato con una leggera frizione.
 - Non utilizzare pulitori a vapore.
- Non danneggiare la superficie con oggetti taglienti
- Non esporre in nessun caso le superfici a forti radiazioni solari

Con l'augurio che i vostri nuovi mobili possano darvi tante soddisfazioni

Area Sviluppo prodotti



Opgelet instructie!

Onze hoogglanzende oppervlakken zijn bij de levering beschermd met een beschermfolie. Laat deze folie op het meubel tot het volledig is gemonteerd en vrij is van stof.

Om de waardevolle hoogglanzende look te verkrijgen, dient u

- de hoogglanzende folie na de verwijdering van de beschermfolie een uur de tijd voor de verharding achteraf in de omgevingslucht geven
- voor de reiniging van de oppervlakken gebruikt u alleen een vochtige katoenen doek en een glasreinigingsproduct.
 - Gebruik geen bijtend reinigingsmiddel met toevoegingsstoffen.
 - Wrijf oppervlakken met een natte doek af.
 - Gebruik geen stoomreiniger.
- Beschadig het oppervlak niet met scherpe voorwerpen.
- Stel oppervlakken zeker niet bloot aan sterke zonnestralen.

We wensen u nog veel plezier met het nieuwe meubel.

De productontwikkelingsafdeling



Обратите внимание!

Наши изделия с поверхностью с зеркальным блеском поставляются защищенными специальной пленкой. Оставляйте ее на мебели, пока она не будет полностью установлена и пыль будет полностью убрана.

Чтобы добиться благородного зеркального блеска, необходимо

- после снятия защитной пленки оставить пленку с зеркальным блеском для дополнительной закалки в воздухе комнаты на один час,
 - для чистки поверхности используйте только влажные хлопчатобумажные салфетки и немного средства для чистки стекла.
 - Не использовать острые средства чистки с присадками.
 - Протирать поверхность влажной тряпкой.
 - Не использовать парочиститель.
 - Не повреждать поверхность острыми предметами.
 - Ни в коем случае не допускать попадания на поверхность прямых солнечных лучей.
- Желаем Вам получить большое удовольствие от своей мягкой мебели.

С наилучшими пожеланиями, коллектив разработчиков



Achtung Hinweis!

Unsere Hochglanzoberflächen sind bei der Auslieferung durch eine Schutzfolie geschützt. Belassen Sie diese auf dem Möbel, bis es vollständig montiert und von Staub befreit ist.

- die wertvolle Hochglanzoptik zu erhalten, sollten Sie eine Stunde Zeit zum Nachhärtan an der Raum-Luft geben
- für die Reinigung der Oberflächen verwenden Sie nur ein feuchtes Baumwolltuch und etwas Glasreiniger.
 - Kein scharfes Reinigungsmittel mit Zusatzstoffen verwenden.
 - Oberflächen mit einem nassen Lappen abreiben
 - keinen Dampfreiniger verwenden.
- Oberfläche nicht mit scharfen Gegenständen beschädigen
- Oberflächen auf gar keinen Fall starker Sonnenbestrahlung aussetzen

Wir wünschen Ihnen noch viel Freude mit Ihrem neuen Möbel.

Ihre Produktentwicklung