

KITCHEN ISLAND
ILOT DE CUISINE
ISLA DE COCINA

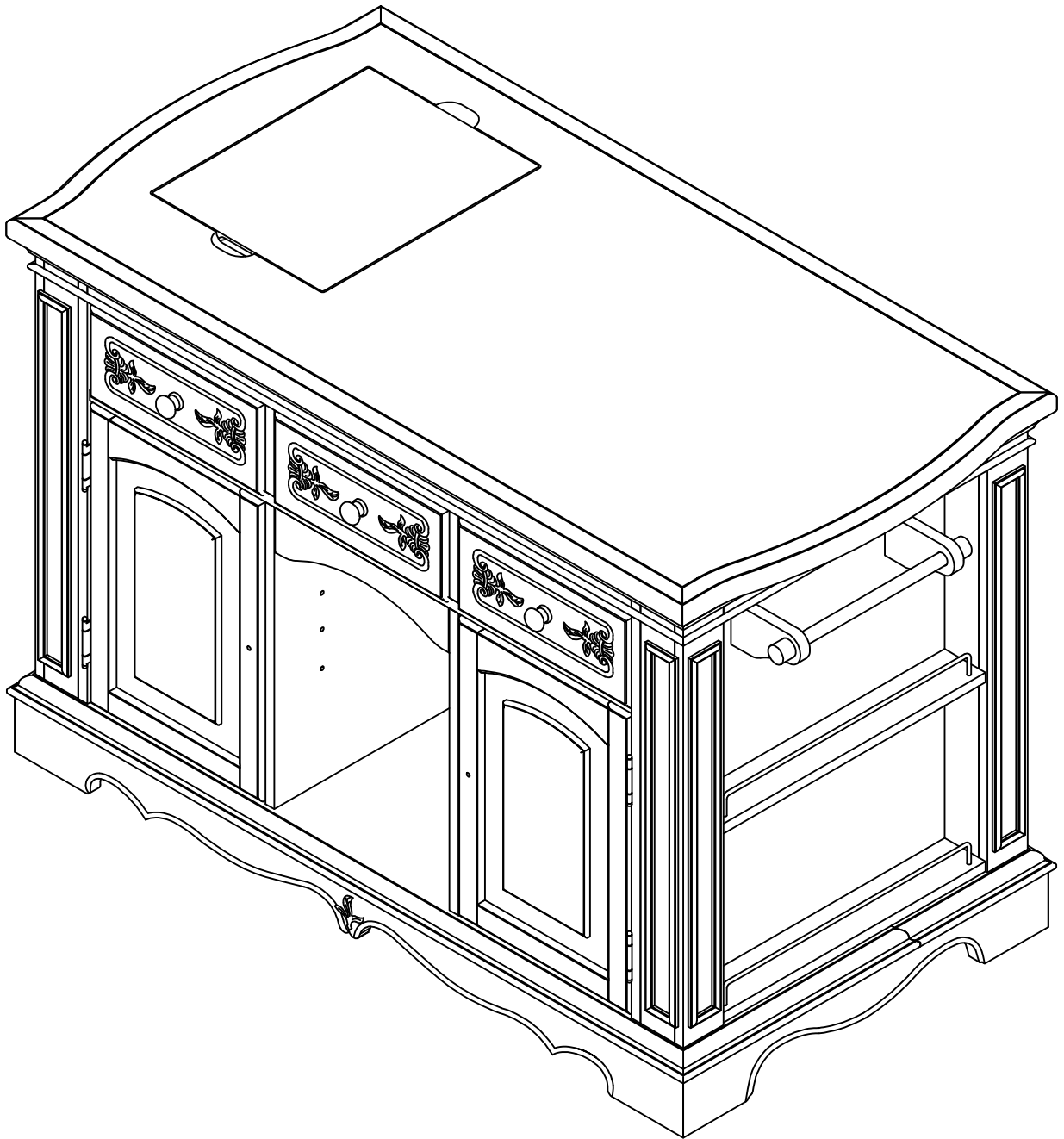

We are here to help!
Before you return it - contact us.

If you need assistance with assembly or replacement parts, please call Customer Service, prior to returning the item to the store.

Nous sommes là pour vous aider!
Avant de retourner le produit, veuillez communiquer avec nous.

Si vous avez besoin d'une pièce de rechange ou d'aide pour l'assemblage, veuillez communiquer avec le Service à la clientèle avant de retourner le produit au magasin.

¡Estamos aquí para ayudarle!
Antes de regresar el producto, comuníquese con nosotros.

Si necesita ayuda para ensamblar su producto o para obtener piezas de repuesto, llame al Servicio al Cliente antes de devolver el artículo a la tienda.

HARDWARE LIST

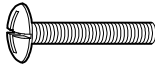
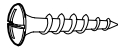
 H1 x 12 (20x13x16mm)	 H2 x 05 (Ø5/32"x25mmL)	 H3 x 12 (Ø3x12mmL)
---	---	---

PART LIST

PARTS	DESCRIPTION	QTY
A	BUFFET	01
B	DOOR LEFT	01
C	DOOR RIGHT	01
D	DRAWERS	03
E	STONE PIECE	01
F	SHELF	03
G	SHORT FRAME TRAY	02
H	LONG FRAME TRAY	02
I	TRAY	01
J	KNIFE BLOCK	01
L	KNOB	05
M	TOWEL BARS	02
N	END CAP	04

IMPORTANT: - Do not tighten bolts completely until all bolts are completely lined up and inserted into holes / nuts.

- Do not over tighten screws and bolts to avoid stripping.
- Please use hand tools to assemble this product. Do not use power tools

IMPORTANT: - Ne serrez pas complètement les boulons jusqu'à ce qu'ils soient bien alignés et insérés dans les trous et les écrous.

- Ne serrez pas excessivement les boulons pour éviter d'endommager les filets.
- Veuillez utiliser des outils manuels pour assembler ce produit. Ne pas utiliser d'outils électriques.

IMPORTANTE: - No apriete completamente los pernos hasta que estén bien alineados e insertados en los orificios y las tuercas.

- No apriete exageradamente los pernos para evitar dañar las roscas.
- Favor de utilizar herramientas manuales para ensamblar este producto. No utilizar herramientas eléctricas.

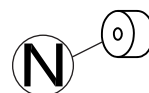
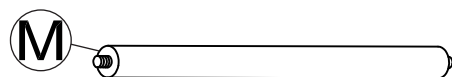
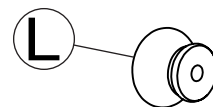
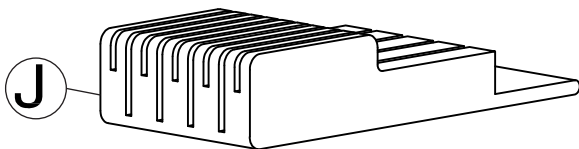
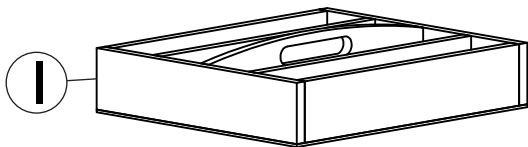
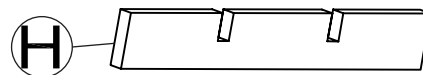
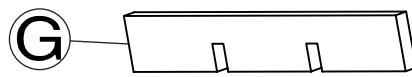
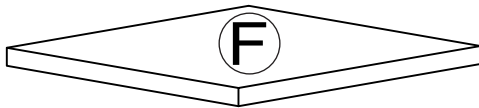
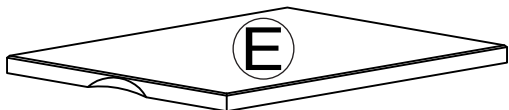
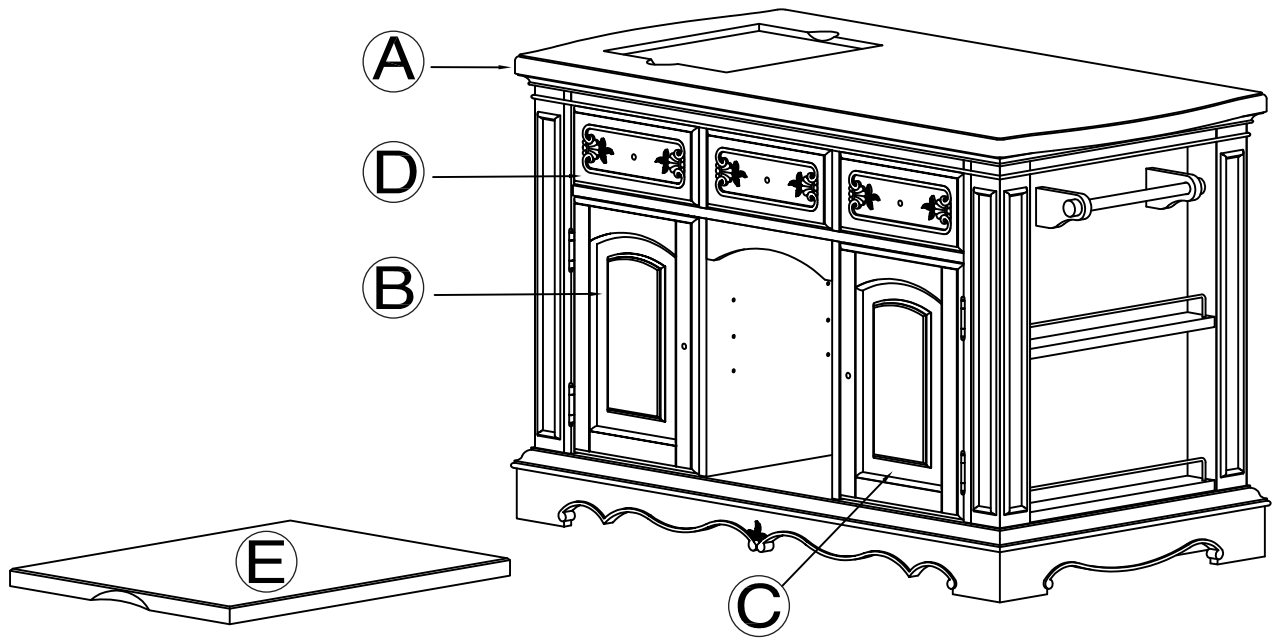

STEP 1
ÉTAPE 1
PASO 1

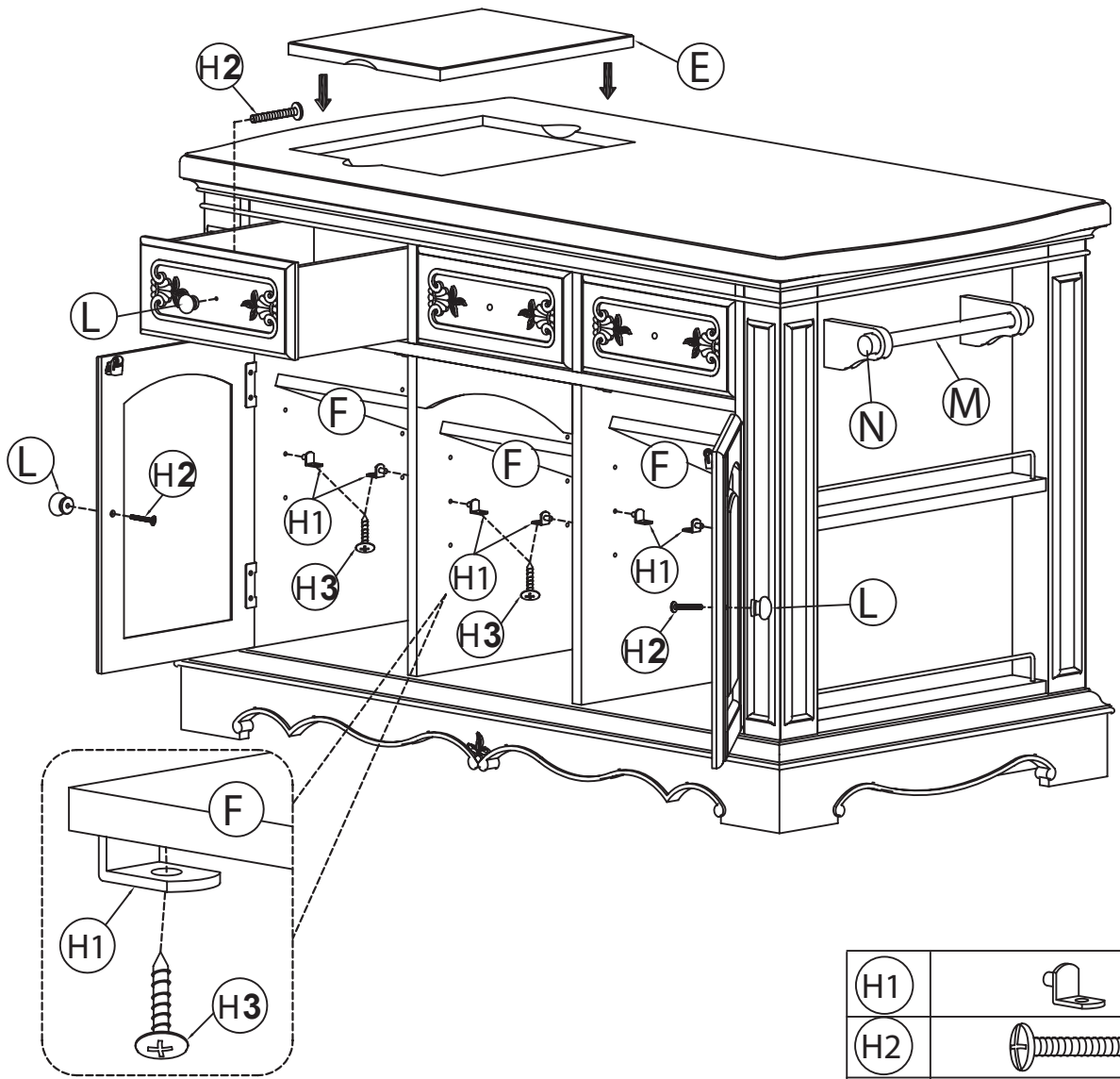

(H1)		12
(H2)		5
(H3)		12

STEP 2
ÉTAPE 2
PASO 2

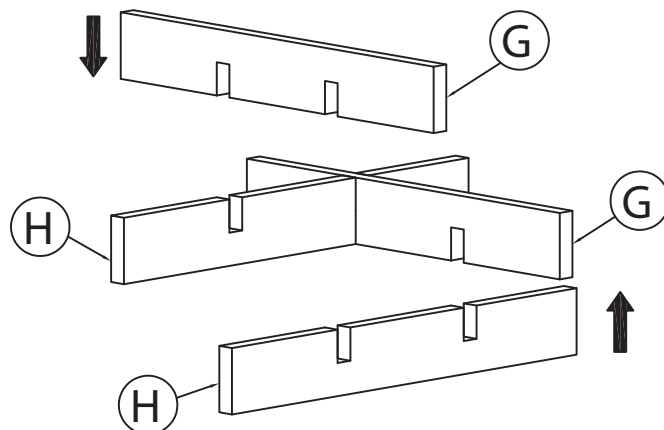

**LIMITED WARRANTY
GARANTIE LIMITÉE
GARANTÍA LIMITADA**

MADE IN VIETNAM
FABRIQUÉ AU VIETNAM
HECHO EN VIETNAM

