

# Parts Diagram for YHWR99-2

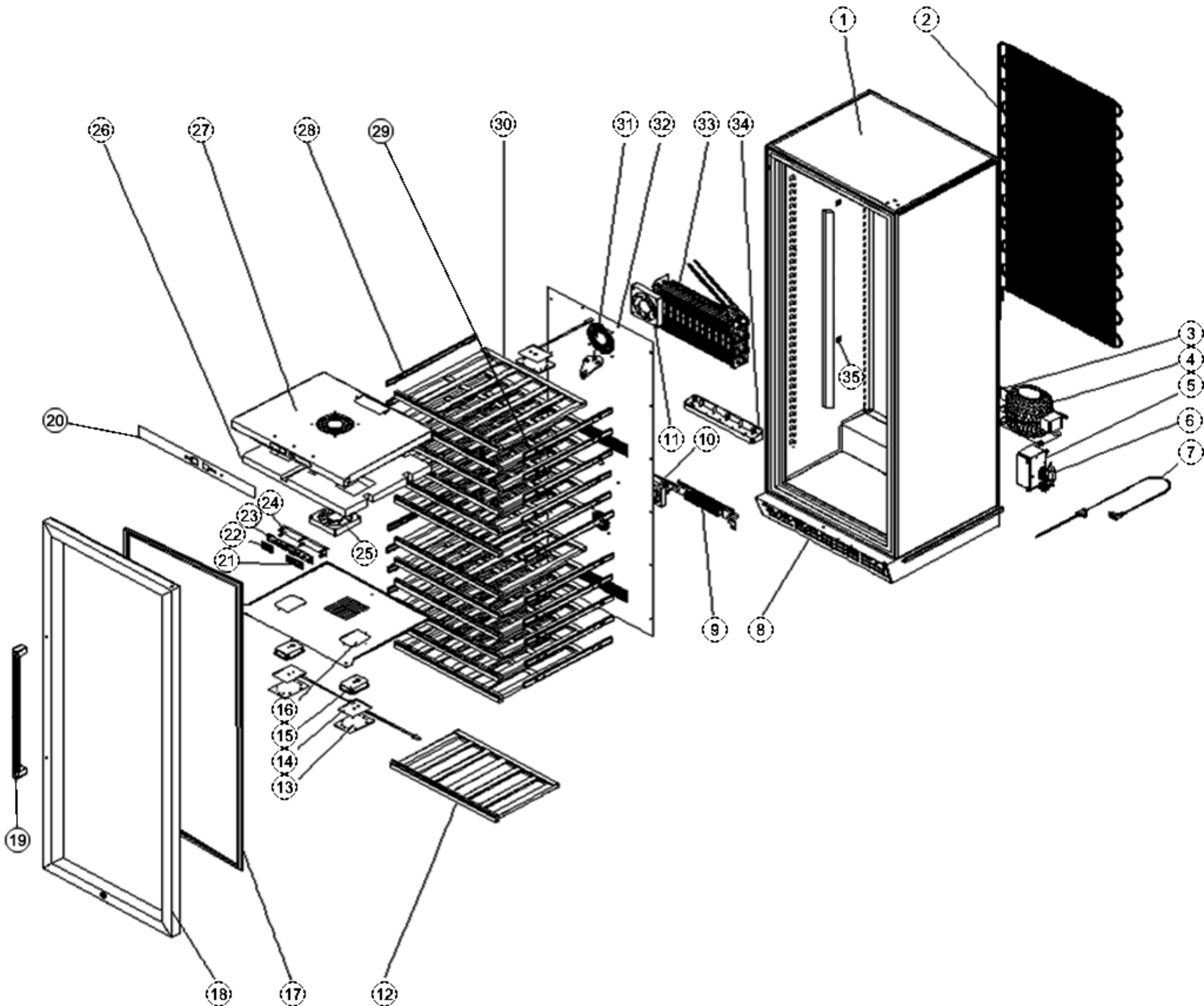

- |                                  |               |                                 |               |
|----------------------------------|---------------|---------------------------------|---------------|
| 1. Cabinet                       |               | 19. Handle                      |               |
| 2. Condensor                     | (Y-COND1)     | 20. Display Sticker             | (Y-CPNP2)     |
| 3. Water Tank                    | (Y-WTRAY)     | 21. 3 Button Sets               | (Y-BUTSET1)   |
| 4. Compressor                    | (Y-COMP)      | 22. 2 Button Sets               | (Y-BUTSET2)   |
| 5. Main Board Box                | (Y-PPCBBOX)   | 23. Control Panel               | (Y-DZPCB)     |
| 6. Main Board                    | (Y-PPCB3)     | 24. Display Panel Bracket       | (Y-PCBBRACK)  |
| 7. Power Cable                   | (Y-PPCB1)     | 25. Fan of Middle Board         | (Y-HEATERFAN) |
| 8. Base                          | (Y-BASE-L)    | 26. Foam of Middle Board        | (Y-SEPINSUL)  |
| 9. PTC Heater                    | (Y-HEATER)    | 27. Upper Cover of Middle Board | (Y-UBP)       |
| 10. PTC Heater Fan               | (Y-EVAPFAN)   | 28. Left Shelf Guide            | (Y-GLIDE-L)   |
| 11. Evaporator Fan               | (Y-HEATERFAN) | 29. Right Shelf Guide           | (Y-GLIDE-R1)  |
| 12. Small Shelf                  | (Y-SMSHELF1)  | 30. Big Shelf                   | (Y-SHELF)     |
| 13. Light Cover                  | (Y-LIGHTCOVE) | 31. Upper Hinge                 | (Y-HINGE-U)   |
| 14. Light PCB                    | (Y-LPCB)      | 32. Air Channel Board           | (Y-BAFFLE)    |
| 15. Light Box                    | (Y-LIGHTBOX)  | 33. Copper Evaporator           | (Y-EVAPCOP1)  |
| 16. Bottom Cover of Middle Board | (Y-DBB)       | 34. Evaporator Pan              | (Y-IWT)       |
| 17. Door Seal                    | (Y-DSEAL1)    | 35. Temperature Sensor          | (Y-SENSOR1)   |
| 18. Glass Door                   |               |                                 |               |