

Kitchen Island

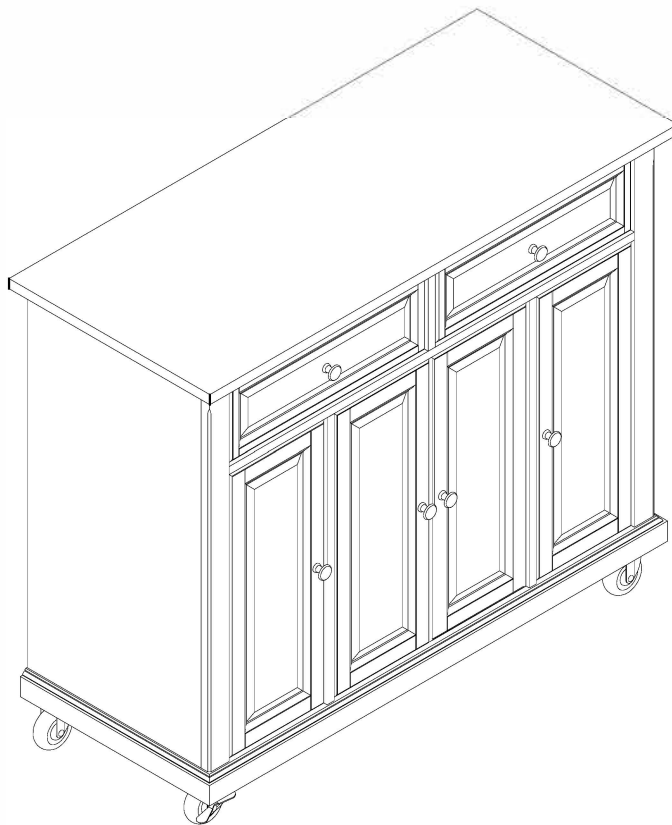
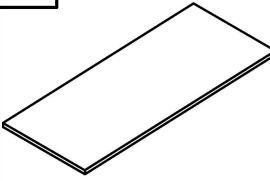
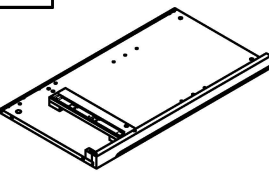
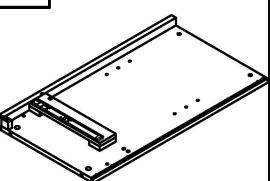
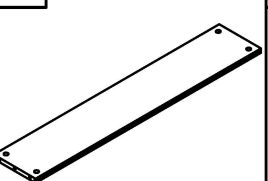
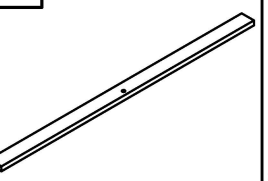
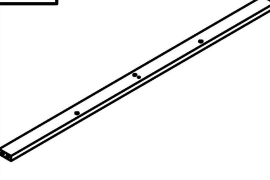
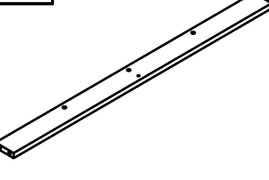
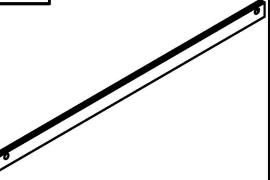
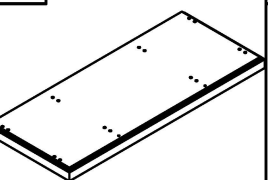
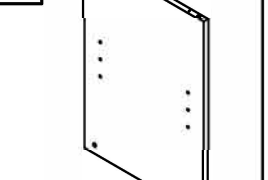
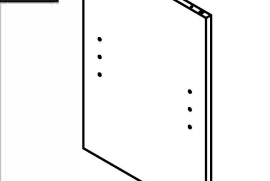
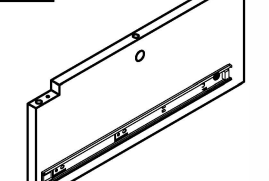
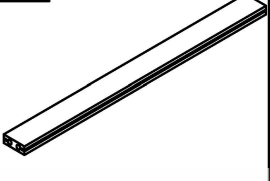
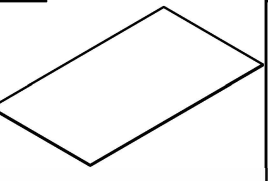
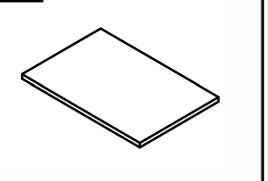
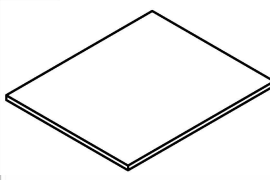
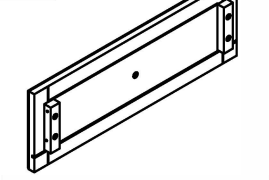
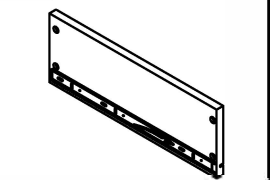
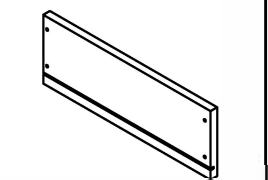
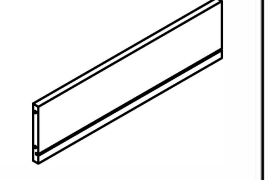
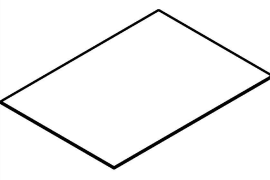
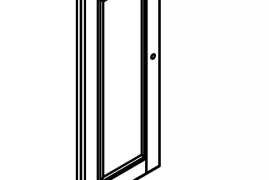
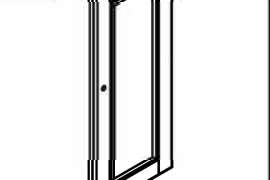
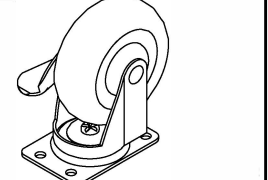
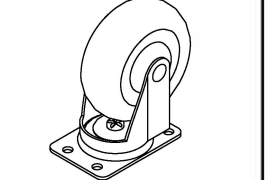

PART LIST

<p>A</p> 	<p>B</p> 	<p>C</p> 	<p>D</p> 	<p>E</p> 
<p>Top Panel 1 PC</p>	<p>Left Panel 1 PC</p>	<p>Right Panel 1 PC</p>	<p>Back Top Panel 1 PC</p>	<p>Front Top Rail 1 PC</p>
<p>F</p> 	<p>G</p> 	<p>H</p> 	<p>I</p> 	<p>J</p> 
<p>Back Top Rail 1 PC</p>	<p>Front Middle Rail 1 PC</p>	<p>Back Bottom Rail 1 PC</p>	<p>Bottom Panel 1 PC</p>	<p>Left Partition Panel 1 PC</p>
<p>K</p> 	<p>L</p> 	<p>M</p> 	<p>N</p> 	<p>O</p> 
<p>Right Partition Panel 1 PC</p>	<p>Top Vertical Panel 1 PC</p>	<p>Back Partition Panel 2 PCS</p>	<p>Back Panel 3 PCS</p>	<p>Adjustable Shelf 2 PCS</p>
<p>P</p> 	<p>Q</p> 	<p>R</p> 	<p>S</p> 	<p>T</p> 
<p>Middle Adjustable Shelf 1 PC</p>	<p>Drawer Front Panel 2 PCS</p>	<p>Drawer Left Panel 2 PCS</p>	<p>Drawer Right Panel 2 PCS</p>	<p>Drawer Back Panel 2 PCS</p>
<p>U</p> 	<p>V</p> 	<p>W</p> 	<p>X</p> 	<p>Y</p> 
<p>Drawer Bottom Panel 2 PCS</p>	<p>Left Door Panel 2 PCS</p>	<p>Right Door Panel 2 PCS</p>	<p>Locking Caster 2 PCS</p>	<p>Caster 2 PCS</p>

PART LIST



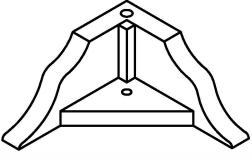



Z

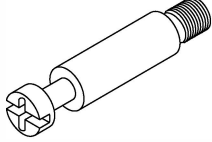
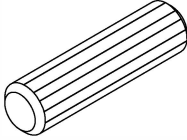
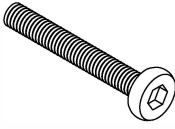

Leg

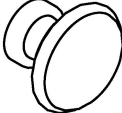
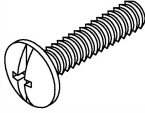
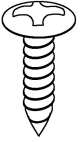
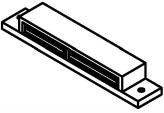
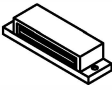
4 PCS

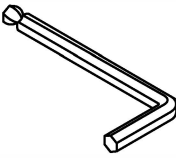
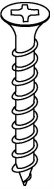
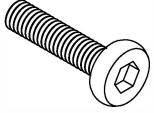
HARDWARE LIST

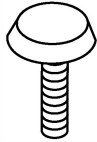
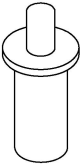
#1	#2	#3	#4	#5
		 08*030mm	 2"*01/4"*011 mm	 1"* q 4*08mm
Cam Lock 17 PCS (Extra 2)	Cam Bolt 17 PCS	Wood Dowel 45 PCS (Extra 1)	Long Bolt 8 PCS	Screw 16 PCS (Extra 1)
#6	#7	#8	#9	#10
			 3/4"* q 5/32"*09mm	
Barrel Nut 8 PCS	Shelf Holder 12 PCS	Knob 6 PCS	Round Head Bolt 6 PCS	Large Round Head Screw 16 PCS (Extra 1)
#11	#12	#13	#14	#15
		 12mm* q 3*06mm		 1-1/4"*(/;4*08mm
Double Magnet 1 PC	Magnet 2 PCS	Round Head Screw 6 PCS (Extra 1)	Allen Wrench 1 PC	Long Screw 7 PCS (Extra 1)
#16	#17	#18	#19	
 1-1/2"*05/16"*013mm				 (Spare Part)
Short Bolt 4 PCS (Extra 1)	Flat Washer 4 PCS (Extra 1)	Spring Washer 4 PCS (Extra 1)	Adjustable Leveler 4 PCS	Pin Hinge (Extra 4)

ADDITIONAL TOOLS (Not Provided)

Note: It is not recommended to use power tools during assembly.

/ehillips Head Screwdriver

Note: Wood dowels are intended for alignment. Additional clearance between wood dowel and pre-drilled hole is intentional for ease of assembly.

Step 1. Insert cam bolts (part #2) into top panel (part A), left panel (part B) and right panel (part C) using phillips head screwdriver.

NOTE: Do not overtighten cam bolts. Stop tightening once threads on cam bolt are no longer visible.

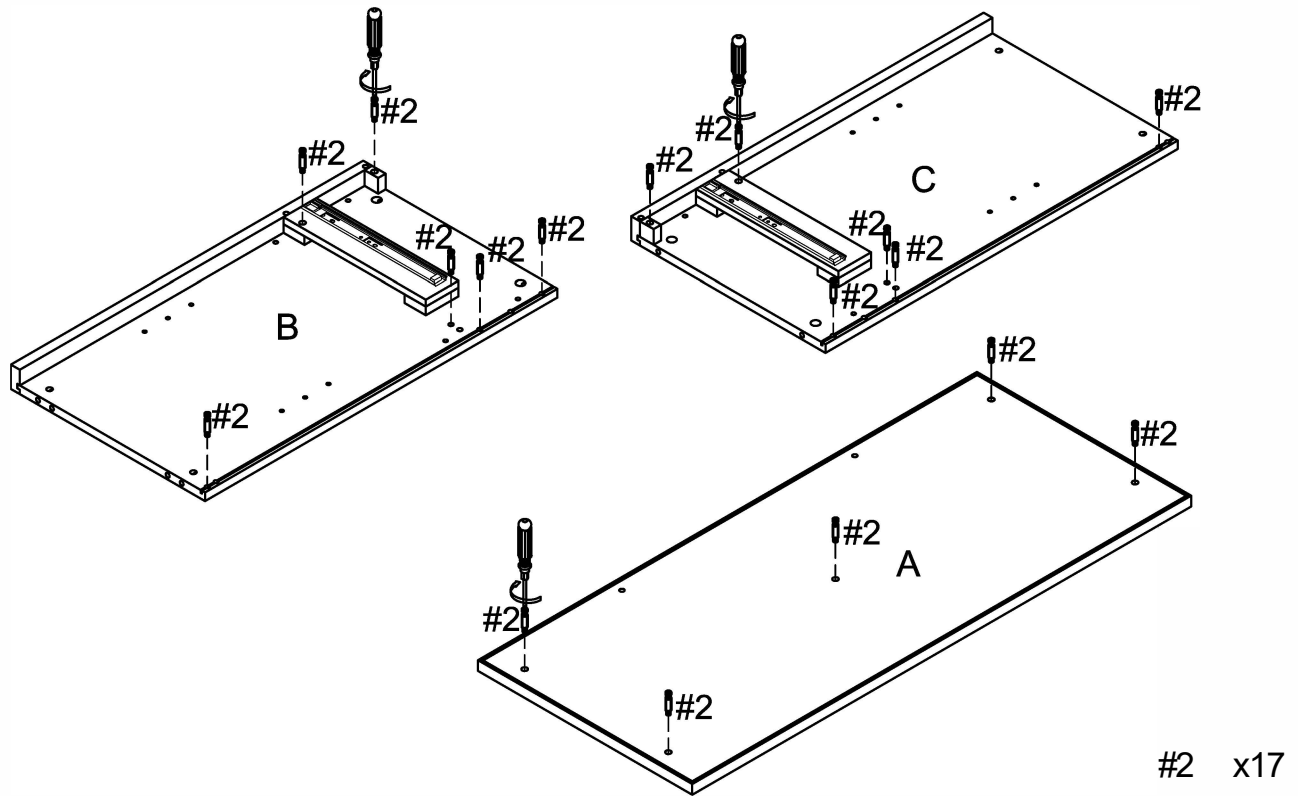

Step 2. Attach knobs (part #8) to drawer front panels (part Q) and door panels (parts V & W) using round head bolts (part #9) and phillips head screwdriver. Attach drawer panels (parts R & S) to drawer front panel (part Q) using screws (part #5) and phillips head screwdriver. Slide drawer bottom panel (part U) into grooves of assembled unit (parts Q, R & S). Attach drawer back panel (part T) to assembled unit (parts R, S & U) using screws (part #5) and phillips head screwdriver. Repeat for remaining drawer.

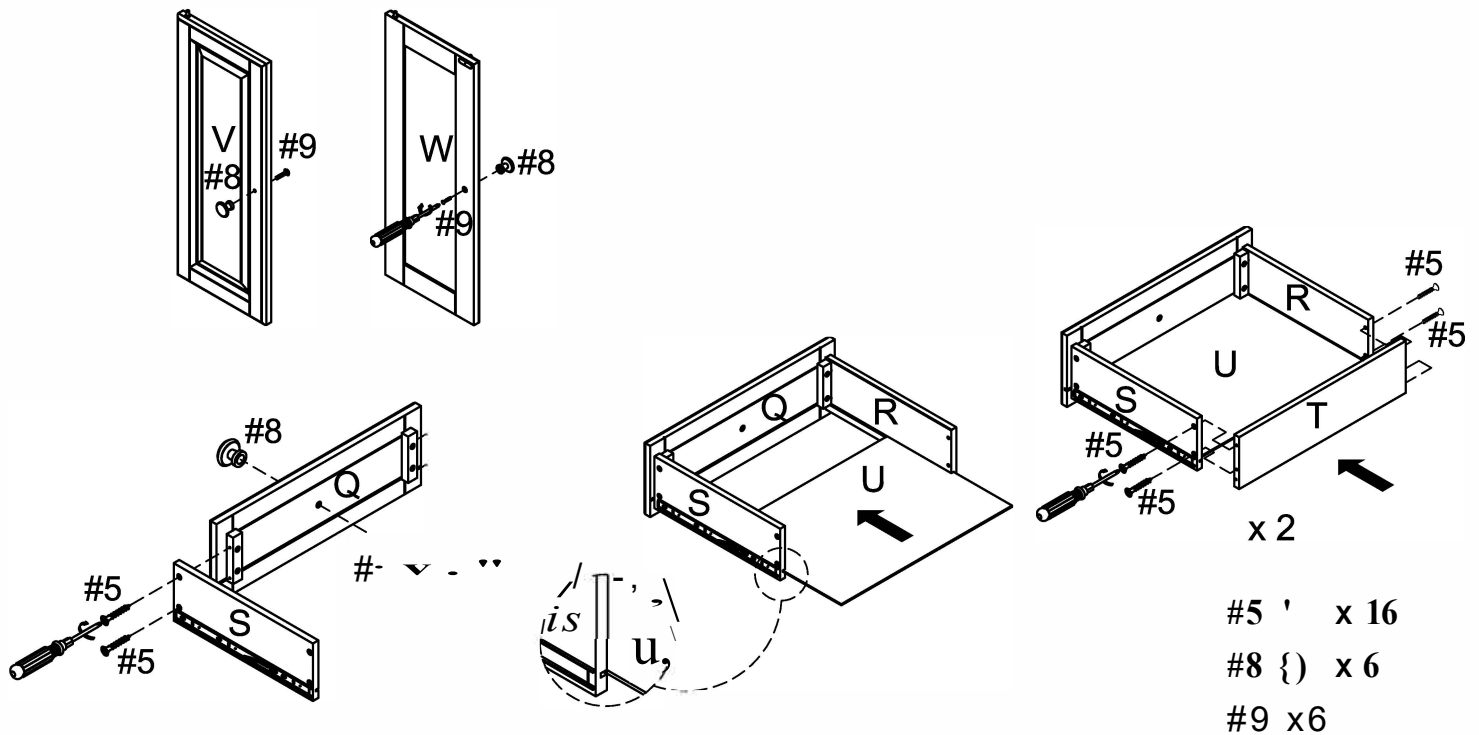

Step 3. Attach front top rail (part E) to top vertical panel (part L) using wood dowel (part #3), long screw (part #15) and phillips head screwdriver. With front top rail (part E) flat on ground, attach front middle rail (part G) and back top rail (part F) to top vertical panel (part L) using wood dowels (part #3), long screws (part #15) and phillips head screwdriver.

NOTE: Please ensure screws are aligned with the pre-drilled holes in top vertical panel (part L) before tightening.

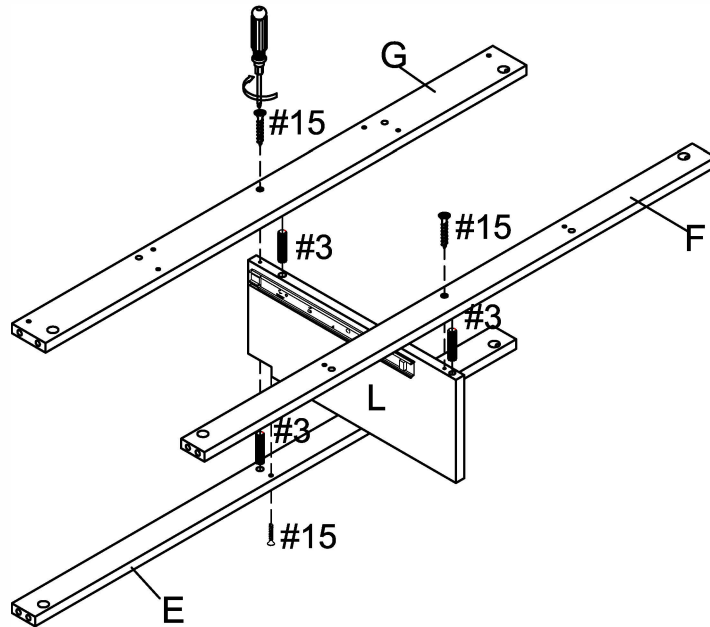

#3 } x3
 #15 } x3

Step 4. Attach assembled unit (parts E, F, G & L) to right panel (part C) using wood dowels (part #3) and cam locks (part #1). Attach back top panel (part D) to right panel (part C) using wood dowel (part #3) and cam locks (part #1).

NOTE: Cam locks must rotate a full 180°. See pictured insert.

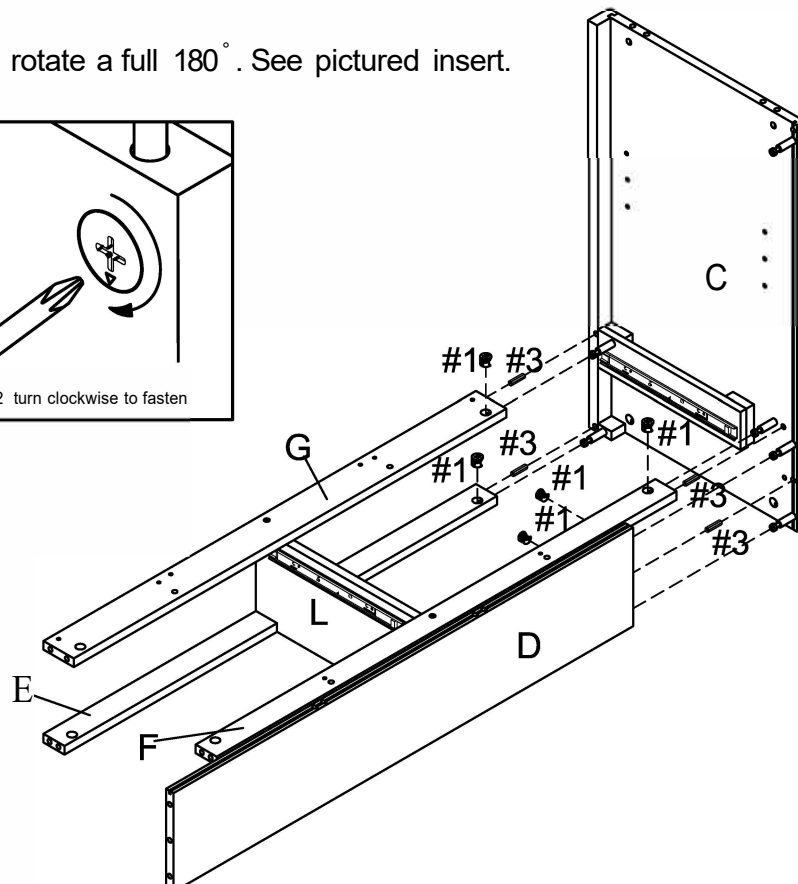
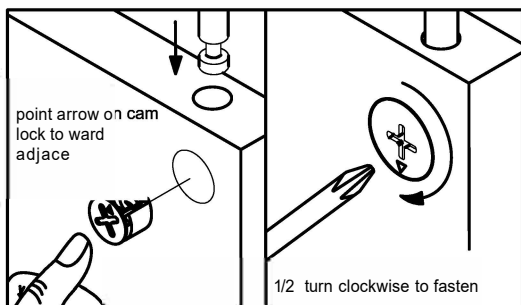

#1 x5
 #3 x4

Step 5. Attach back partition panels (part M) to back top panel (part D) using wood dowels (part #3). Slide back panels (part N) into grooves of right panel (part C), back top panel (part D) and back partition panels (part M).

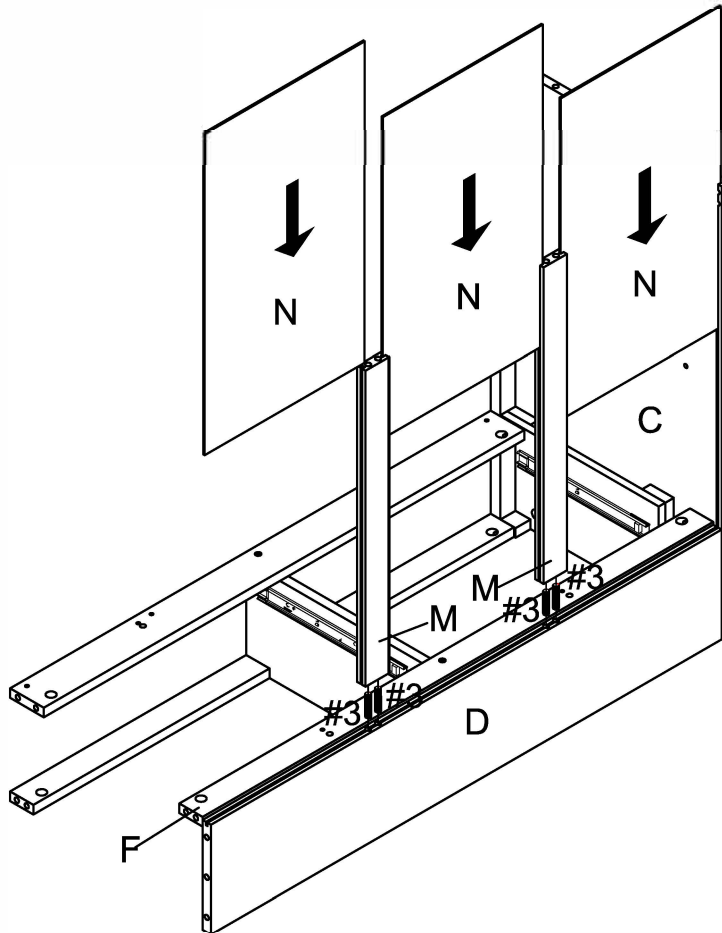

#3 x4

Step 6. Attach back bottom rail (part H) to back partition panels (part M), back panels (part N) and right panel (part C) using wood dowels (part #3) and cam lock (part #1).

NOTE: Cam locks must rotate a full 180°. See pictured insert.

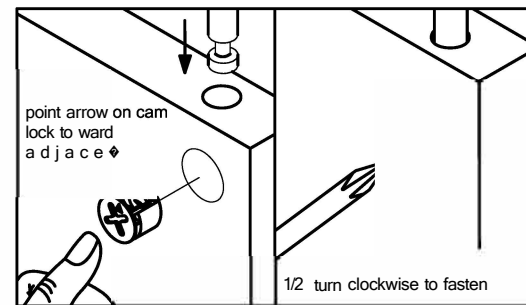
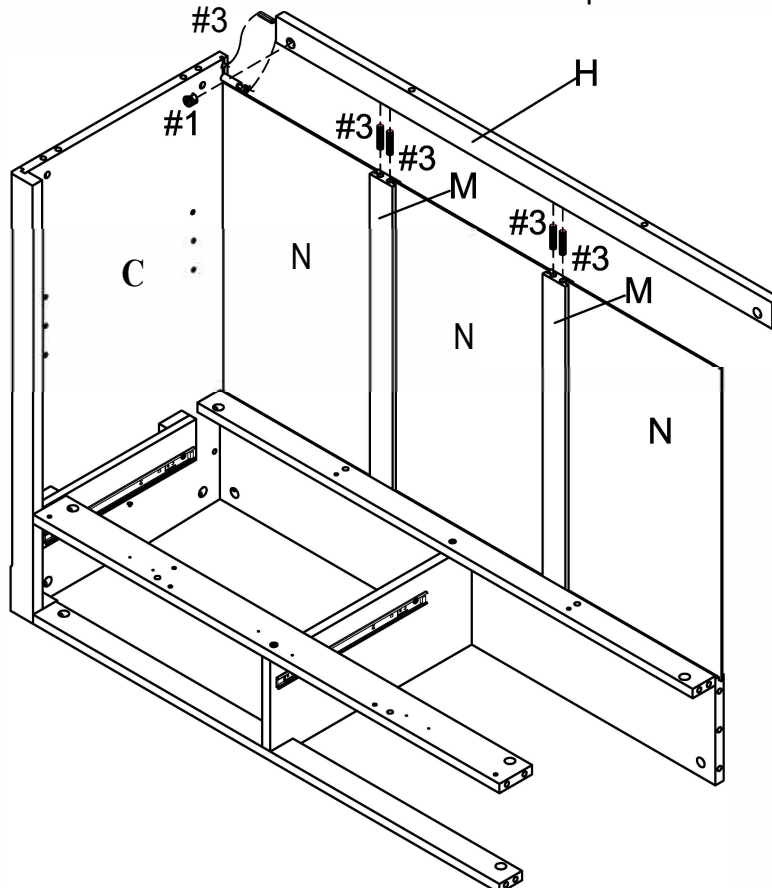

#1 x1

#3 x5

Step 7. Attach left panel (part B) to assembled unit (parts D, E, F, G, H & N) using wood dowels (part #3) and cam locks (part #1).

NOTE: Cam locks must rotate a full 180°. See pictured insert.

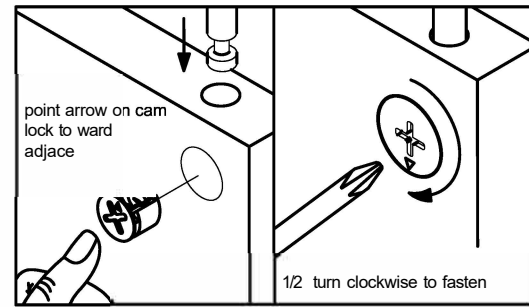
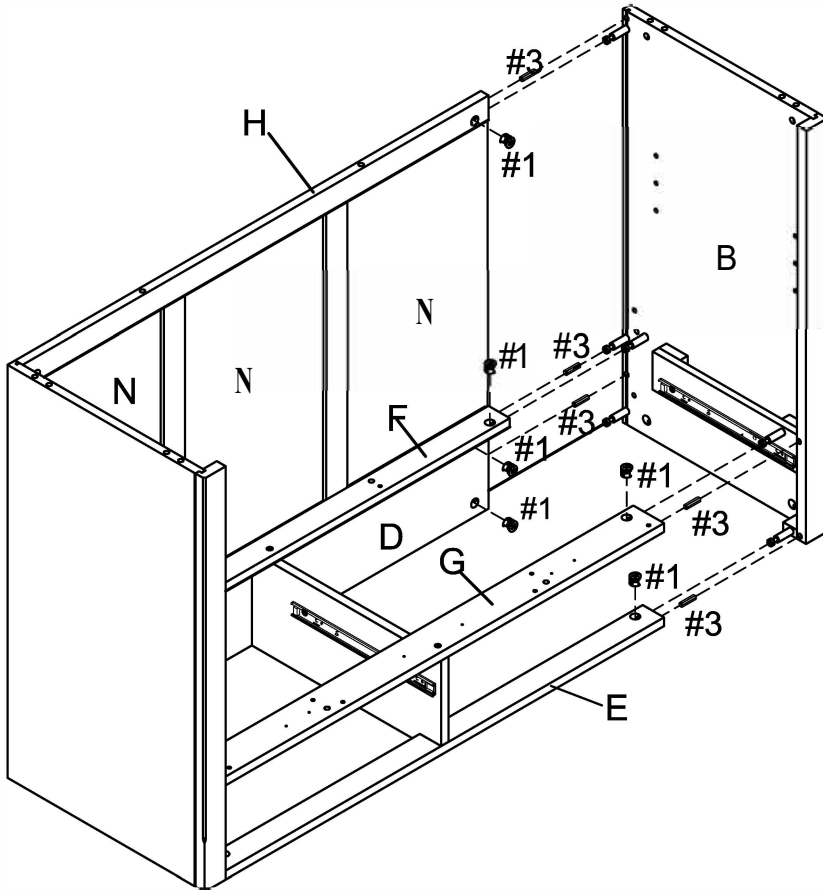

#1 &!?x6
#3 x5

Step 8. Attach double magnet (part #11) and magnets (part #12) to front middle rail (part G) using round head screws (part #13) and phillips head screwdriver. Attach left partition panel (part J) and right partition panel (part K) to back top rail (part F) and front middle rail (part G) using wood dowels (part #3).

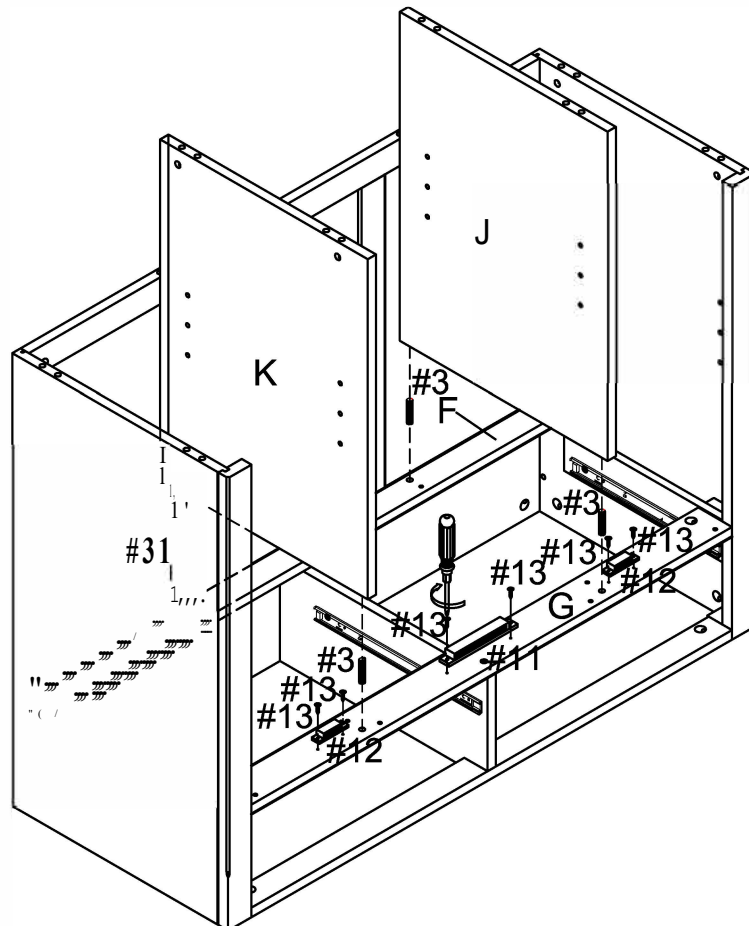

#3 (# x4
#11 x1
#12 x2
#13 T x6

Step 9. Attach bottom panel (part I) to assembled unit (parts B, C, H, J & K) using wood dowels (part #3), long bolts (part #4), barrel nuts (part #6) and allen wrench (part #14).

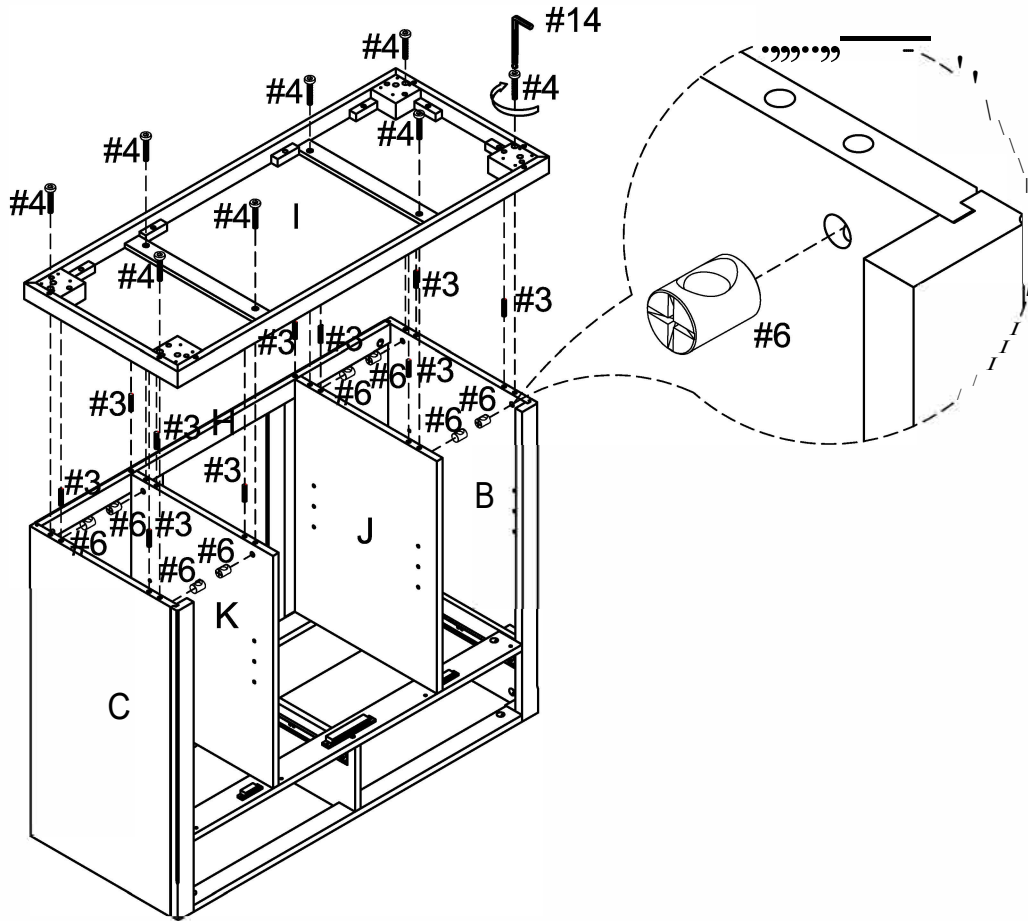

- #3 1 x 10
- #4 1 x 8
- #6 1 x 8
- #14 1 x 1

Step 10. CASTER INSTALLATION

Attach locking casters (part X) and casters (part Y) to bottom panel (part I) using large round head screws (part #10) and phillips head screwdriver.

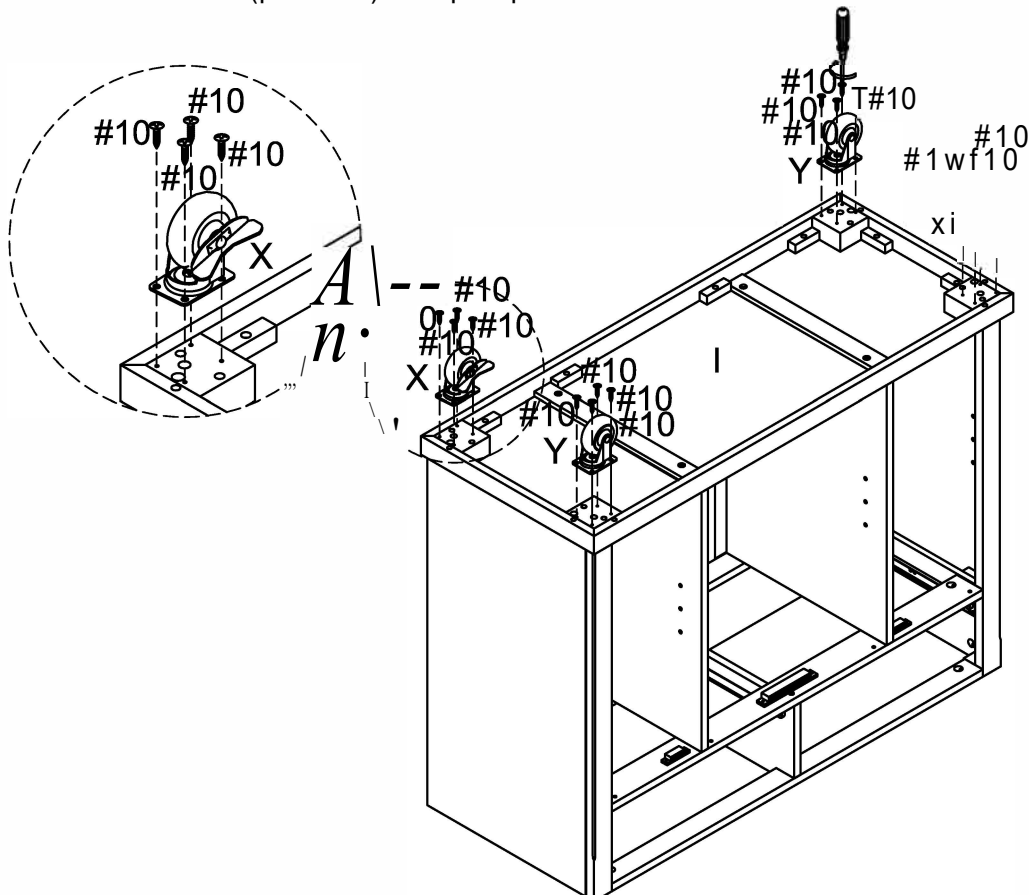

- #10T x 16

Step 11. LEG INSTALLATION

Attach adjustable levelers (part #19) to legs (part Z). Attach legs (part Z) to bottom panel (part I) using wood dowels (part #3), flat washers (part #17), spring washers (part #18), short bolts (part #16) and allen wrench (part #14).

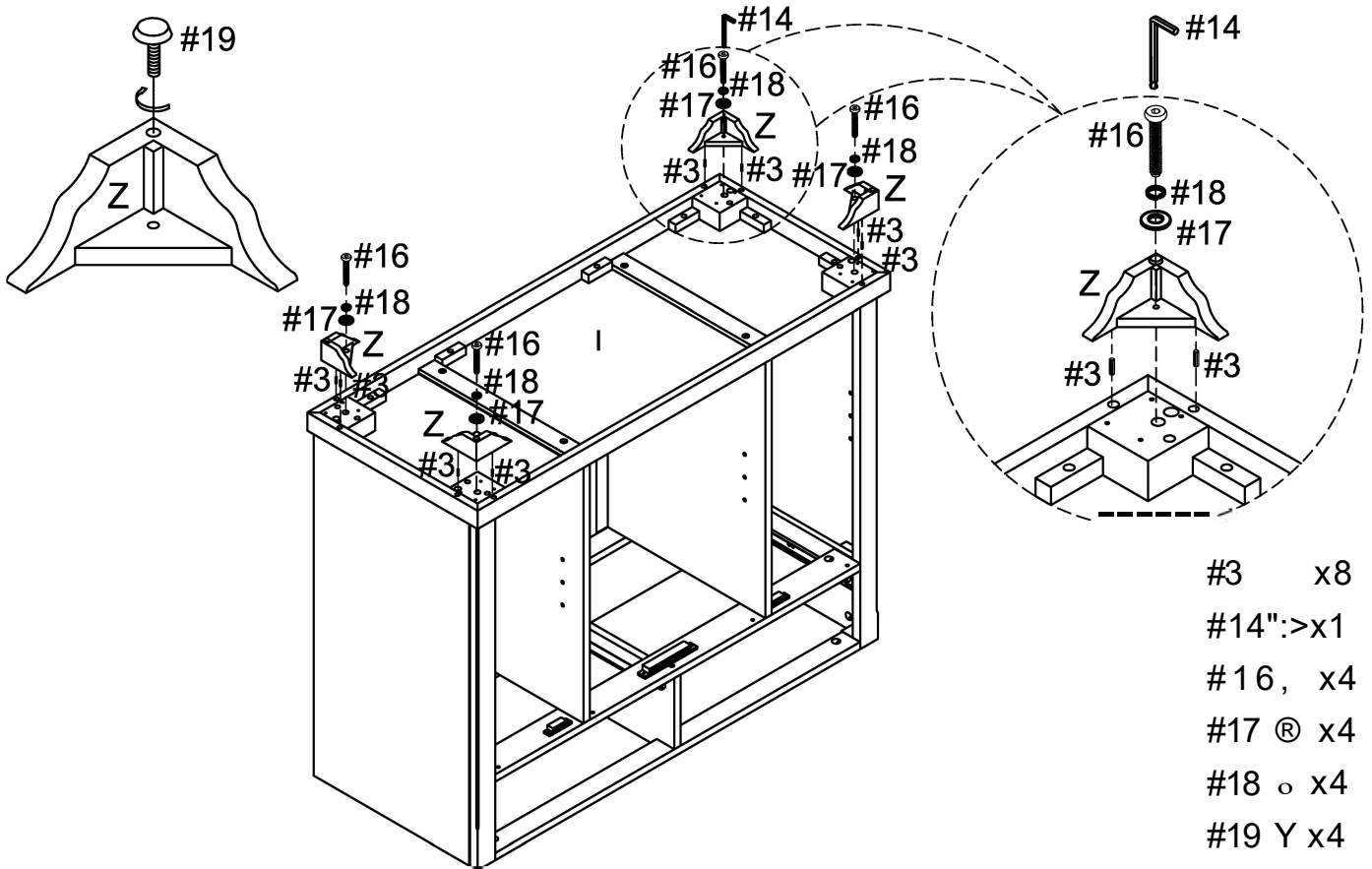

Step 12. Carefully turn unit upright. Secure left partition panel (part J) and right partition panel (part K) to back top rail (part F) and front middle rail (part G) using long screws (part #15) and phillips head screwdriver.

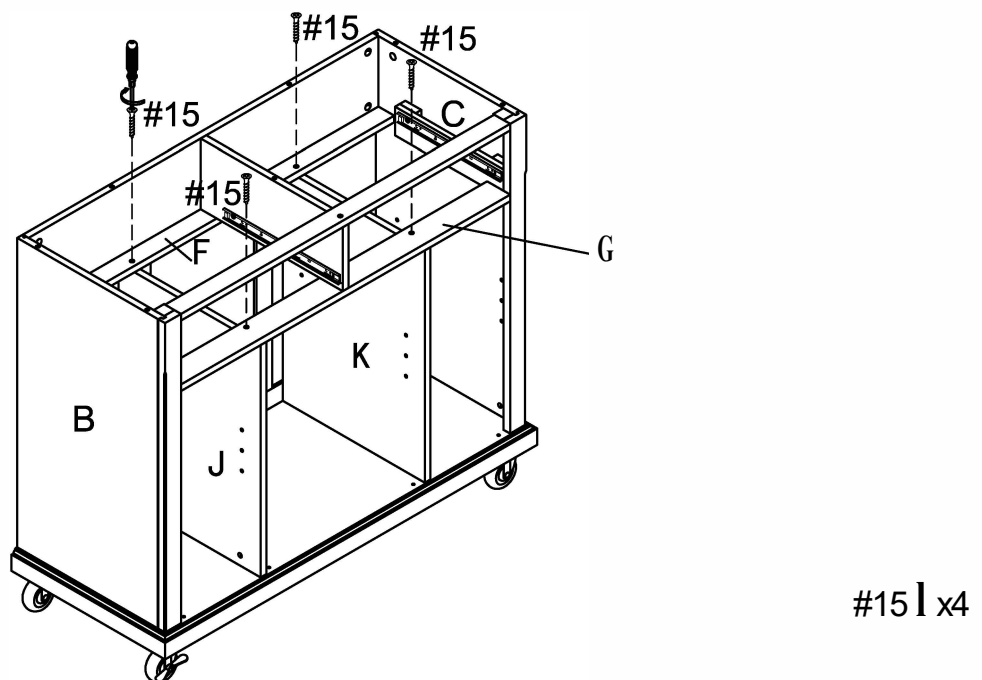

Step 13. Attach top panel (part A) to assembled unit (parts B, C, D, E & L) using wood dowels (part #3) and cam locks (part #1).

NOTE: Cam locks must rotate a full 180°. See pictured insert.

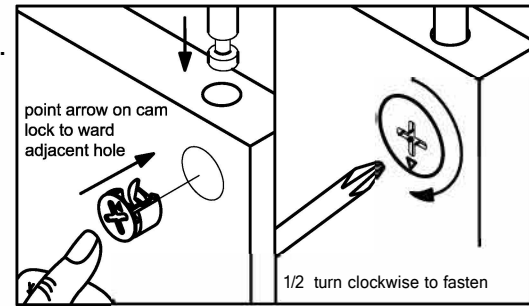
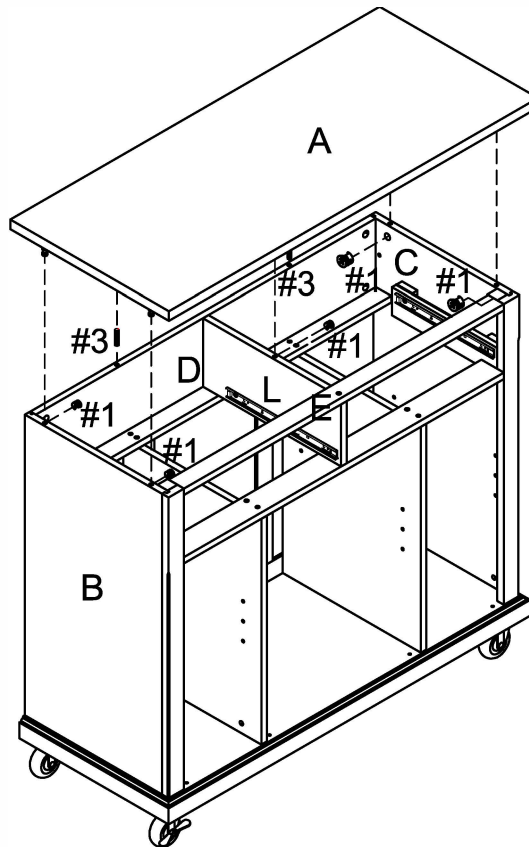

#1 & >xs
#3 x2

Step 14. Attach door panels (parts V & W) by placing bottom pin hinge (pre-installed in door) in the pre-drilled hole of bottom panel (part I). Then depress the top spring-loaded pin hinge so it can be placed in the pre-drilled hole of front middle rail (part G). Place shelf holders (part #7) into desired position.

NOTE: Be sure top and bottom pin hinges are fully extended to secure doors in place.

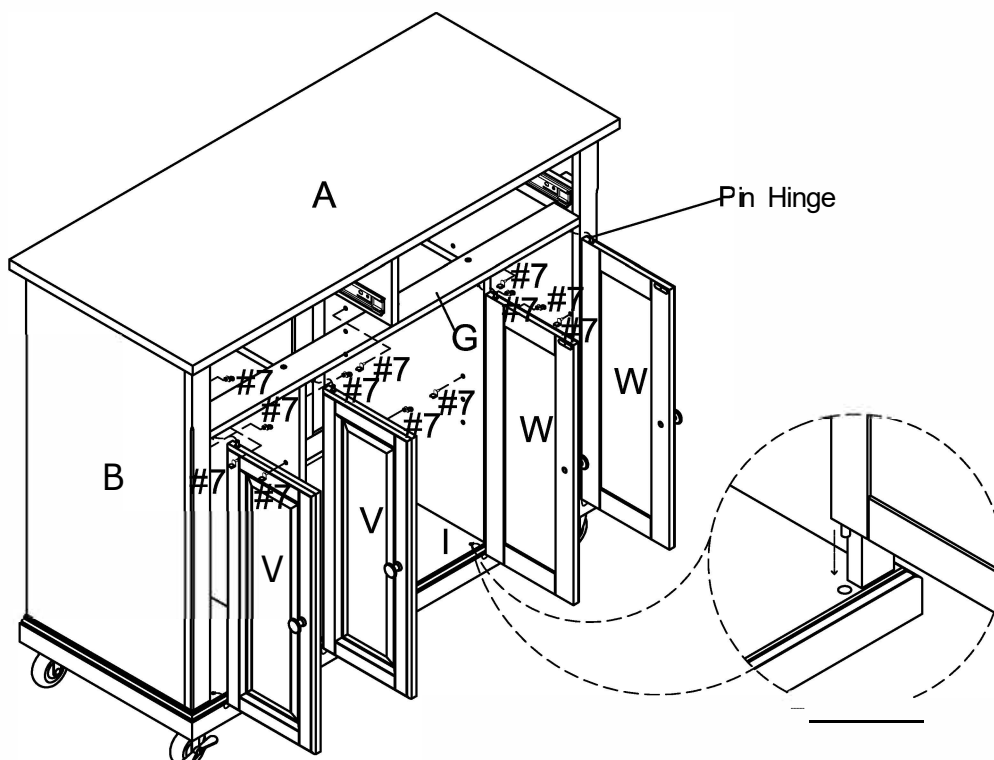

#7 x12

Step 15. Slide assembled drawers into place. Slide adjustable shelves (part O) and middle adjustable shelf (part P) into place.

