

ASSEMBLY INSTRUCTIONS

ASSEMBLY TIPS :





1. Remove hardware from box and sort by size.
2. Please check to see that all hardware and parts are present prior to start of assembly.
3. Please follow attached instruction in the same sequence as numbered to assure fast & easy assembly.





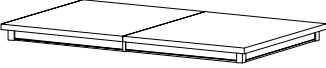

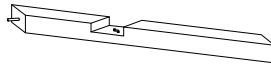



Warning!

1. Don't attempt to repair or modify parts that are broken or defective. Please contact the store immediately.
2. This product is for home use only and not intended for commercial establishment.

PARTS IDENTIFICATION

A		TABLE TOP	1PC
B		V-SHELF PANEL	1PC
C		TABLE LEG	4PCS
D		DECORATION	2PCS
E		TABLE LEAF	1PC

HARDWARE IDENTIFICATION

1		HEX NUT	4PCS
2		LARGE LOCK WASHER	4PCS
3		LARGE FLAT WASHER	4PCS
4		BOLT	4PCS
5		SMALL LOCK WASHER	4PCS
6		SMALL FLAT WASHER	4PCS
7		WRENCH	1PC
8		ALLEN KEY	1PC

ASSEMBLY INSTRUCTIONS

STEP 1

Align and place the table leg (C) to another table leg (C)

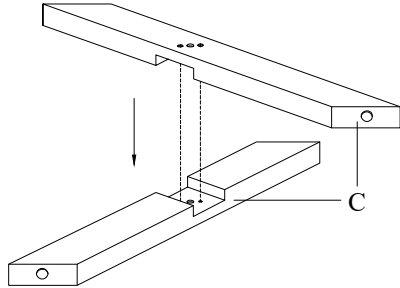

STEP 4

Unlock all locks on the underside of the table . Then pull table top together line to two side.

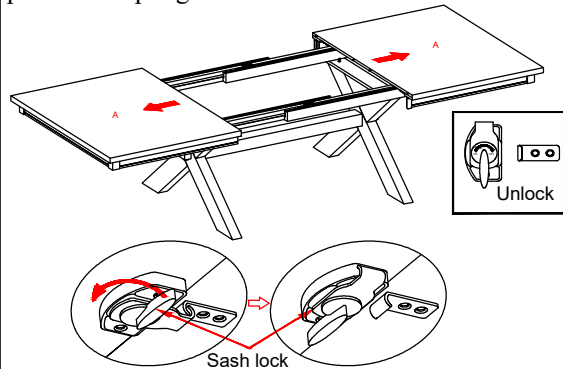

STEP 2

Align and fasten v-shelf panel (B) to table leg (C) using bolt (4), small lock washer (5) and small flat washer (6). Then fully tighten all the bolt with Allen Key (8) and insert decoration (D) to left and right table leg.

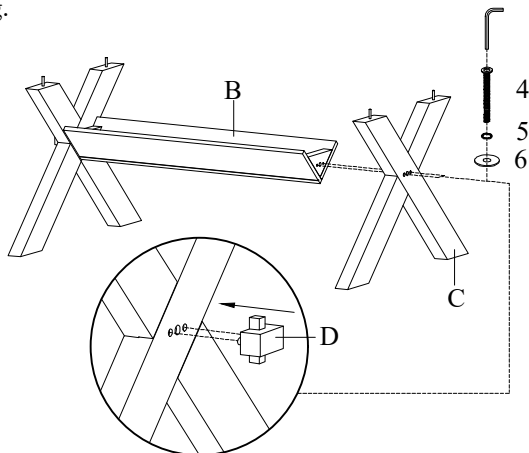

STEP 5

Align and place table leaf (E) into table top (A). Pull table together line up and table lock close tightly then lock all locks on the underside of the table.

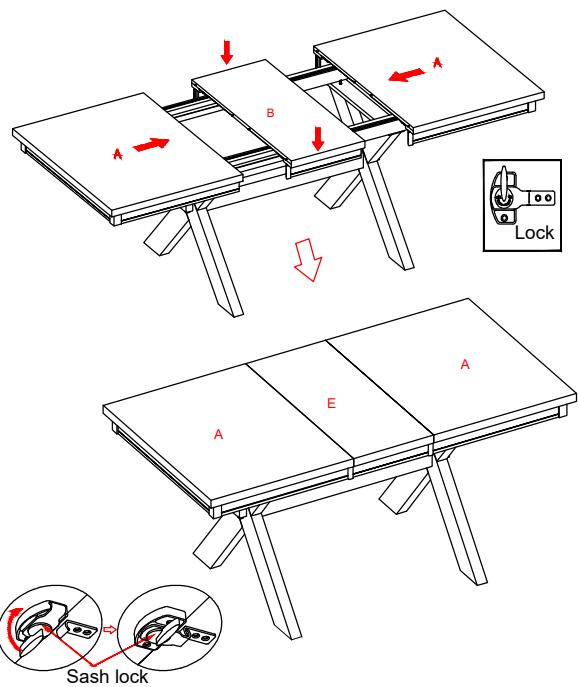

STEP 3

Place the table top (A) upside down on a soft surface. Align and fasten table leg (C) to table top (A) using hex nut (1), large lock washer (2) and large flat washer (3). THEN FULLY TIGHTEN ALL THE HEX NUT WITH WRENCH (7).

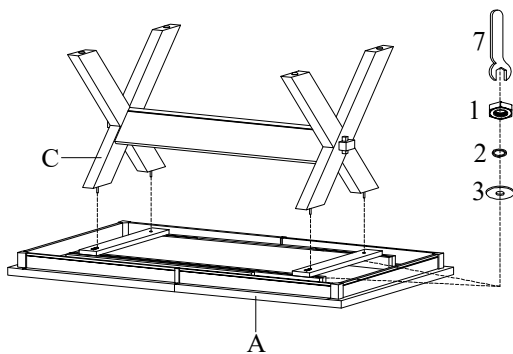

STEP 6

Complete

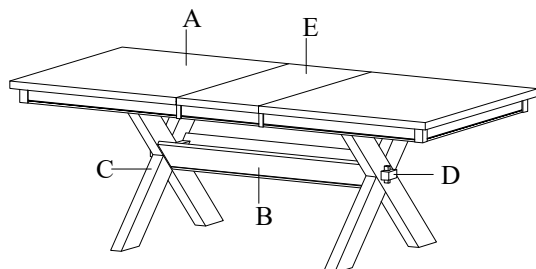

Parts and Damage Replacement Procedure

1. Please inspect your purchase immediately.
2. This procedure covers product purchased from an authorized Roundhill Reseller and was received in its originally sealed carton.
3. If you find a part missing or damaged, you have a 30-day window in which to order a replacement part from the date on your purchase receipt.
4. You have 3 ways to do this. You will need a copy of your purchase receipt.
 - a. By Fax: Fax the parts order form below and along with your receipt.
 - b. By Email: Email the order form and along with your receipt.
 - c. By Mail: Fill out the parts order form below and along with a copy of your receipt send it to our furniture parts department.
5. Once this order is sent in, you will be notified if the part(s) you are requesting can or cannot be shipped within 7-10 business days.

**A COPY OF YOUR PURCHASE RECEIPT OR INVOICE MUST BE ATTACHED TO THIS ORDER FORM.
NO ORDERS WILL BE PROCESSED WITHOUT PROOF OF PURCHASE.**

NAME: _____

ADDRESS: _____ (No Post Office Boxes)

CITY: _____ STATE: _____ ZIP: _____

PHONE: _____ FAX: _____

EMAIL: _____

REASON FOR REPLACEMENT/PLEASE CHECK APPROPRIATE BOX.

- () Damaged /scratched, cracked, broken, crushed, etc.
- () Mechanical malfunction/ drawer glides, swivel mechanisms, lid stays, etc.
- () Missing pieces
- () Unfinished surface
- () Wrong color
- () Other

IF MORE THAN ONE MODEL NUMBER IS LISTED ABOVE, PLEASE SPECIFY THE EXACT MODEL NUMBER OF YOUR ITEM IN THE SPACE PROVIDED BELOW.

Model Number	Part Letter Code	Quantity