

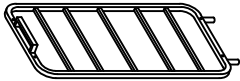

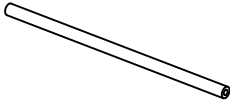

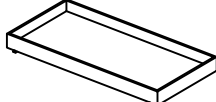

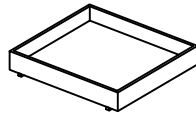

ASSEMBLY INSTRUCTION FOR FURNITURE

Thank you for purchasing the quality product. Be sure to check all packing material carefully for small parts which may have come loose inside the cation during shipment. Seperate, identify and count all parts and metal hardware. Compare with all parts list to be sure all parts are present. If any part(s) are missing or damaged, please contact your local furniture dealer. For efficient and speedy service, please indicate the model number and code letter of part(s) needed.

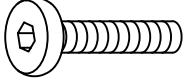
*** Do not fully tighten screws until fully assembled ***

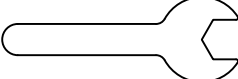
COMPONENT PARTS		
DESCRIPTION	PART NAME	QTY(PCS)
	MIDDLE FRAME 	1
	SIDE FRAME 	2
	CROSS PIPE 	8
	LARGE BOX 	1
	SMALL BOX 	2

HARDWARE REQUIRED

	ALLEN KEY	1 PCS
	BOLT Ø 1/4"*38mm	8 PCS
	FULLY-THREADED BOLT Ø 1/4"*56mm	4 PCS
	WRENCH	1 PCS
	WHEEL	4 PCS
	SPRING WASHER Ø 5/16"*8mm	4 PCS
	WASHER Ø 5/16"*16mm	4 PCS

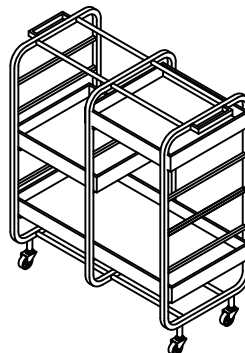

Attention

*** Some number parts listed on the instruction sheet may not be in parts bag as they may already be assembled. Carefully check parts and packing materials prior to ordering replacements.

How to assemble:

STEP 1

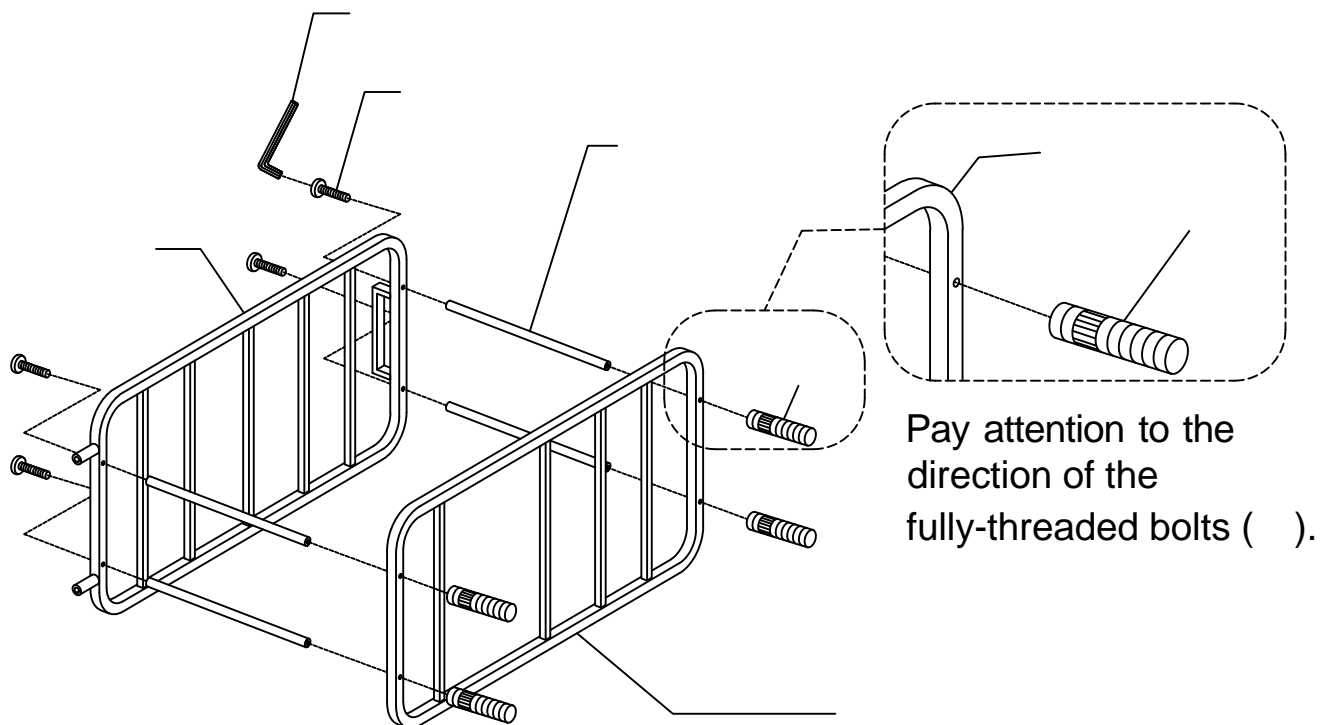

STEP 2

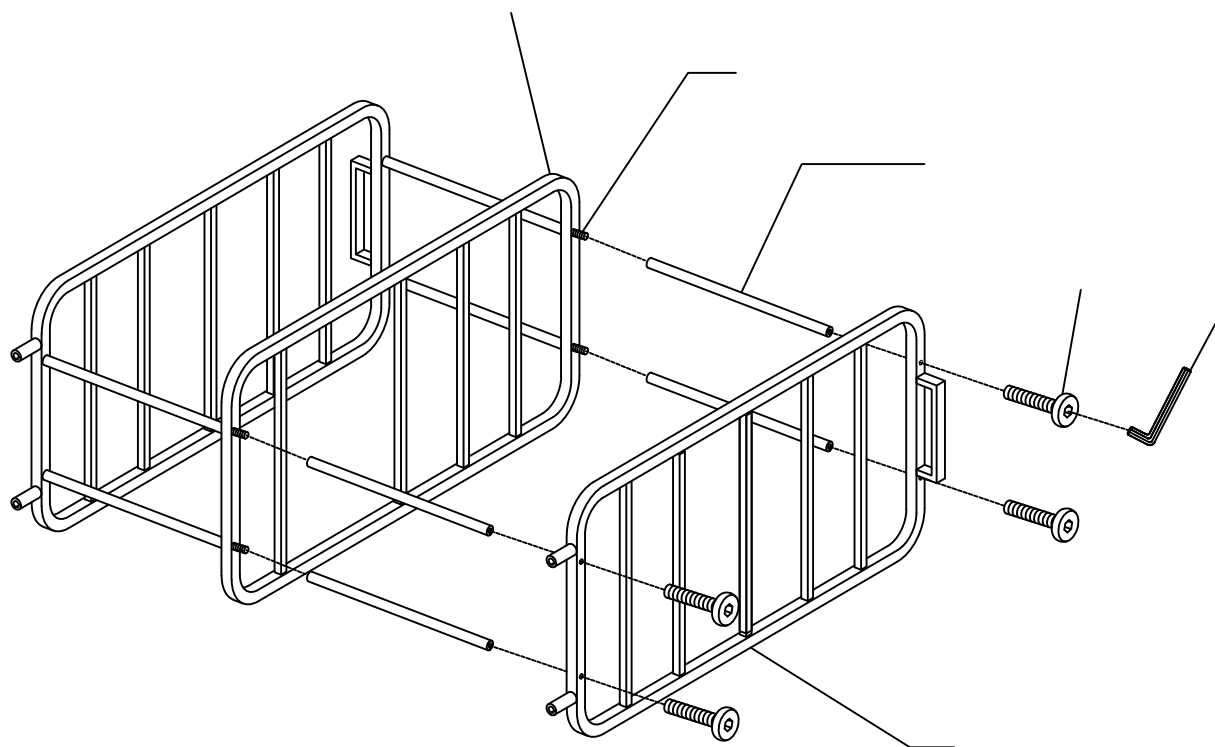

STEP 3

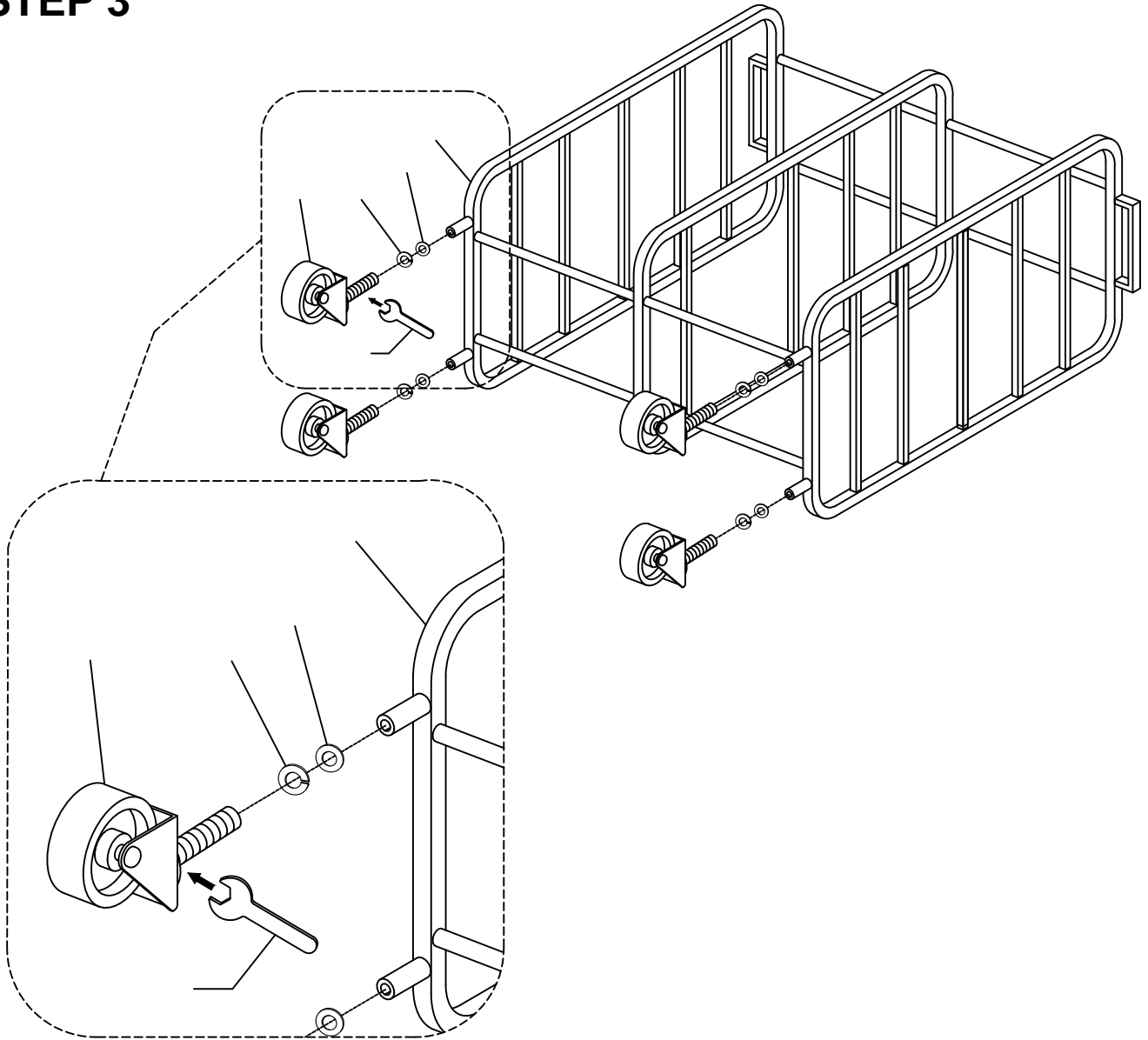

STEP 4

