

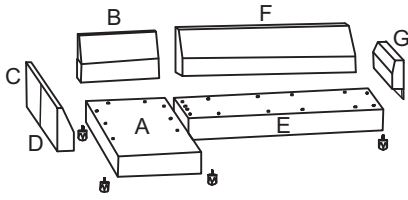

CHAISE ON THE LEFT

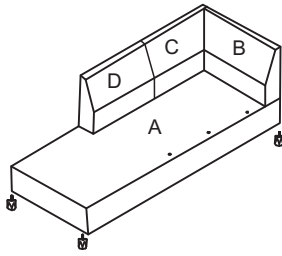

CHAISE BOX-1



SOFA BOX-2

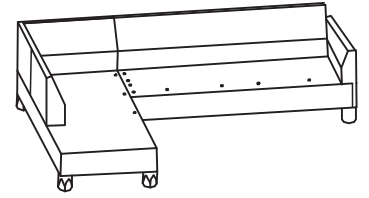
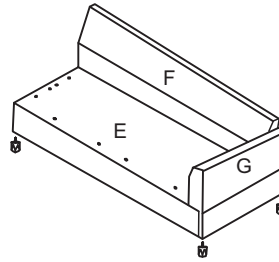

**CHAISE ASSEMBLY INSTRUCTION BOX-1**

**STEP 1- INSERT THREADED ROD INTO SEAT BACKS**

\*Stop when the rod starts coming out on the other end

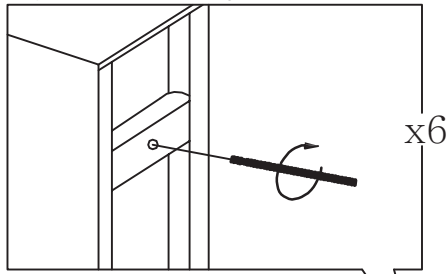

**STEP 2- MOUNTED SEAT BACKS INTO THE SEAT FRAME**

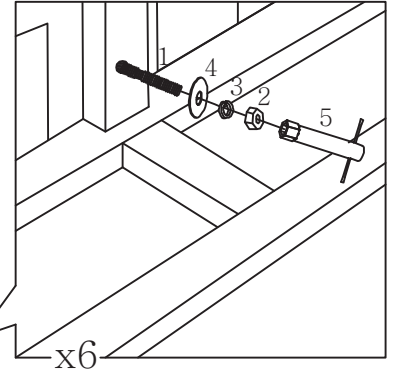
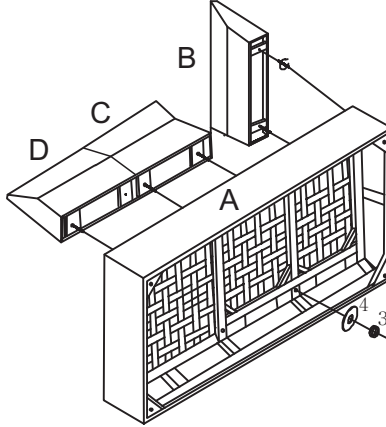

**STEP 3- PUT BACK THE FABRIC COVER AND INSERT LEGS**

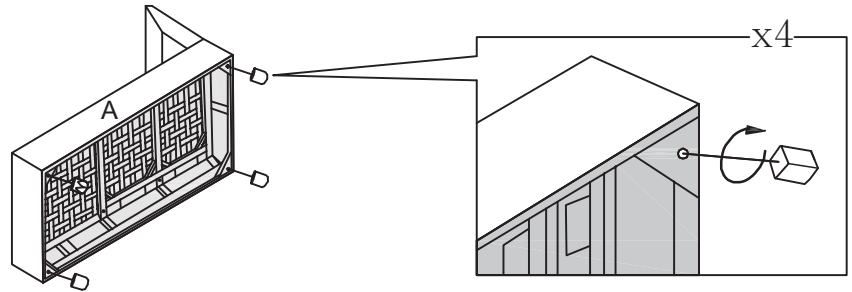
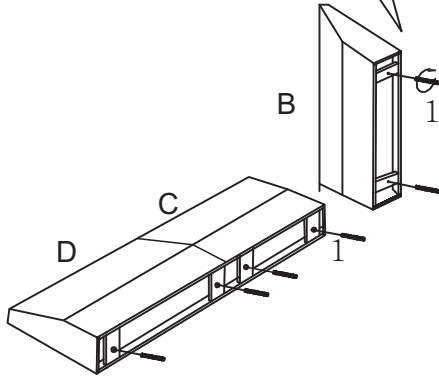

**SOFA ASSEMBLY INSTRUCTION BOX-2**

**STEP 1- INSERT THREADED ROD INTO SEAT BACKS**

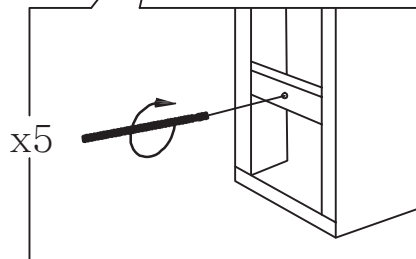
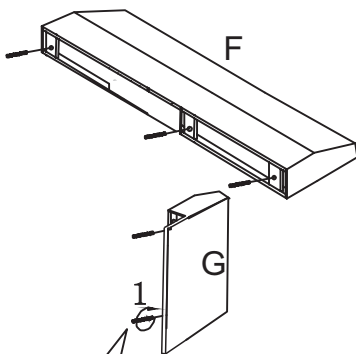

**STEP 2- MOUNTED SEAT BACKS INTO THE SEAT FRAME**

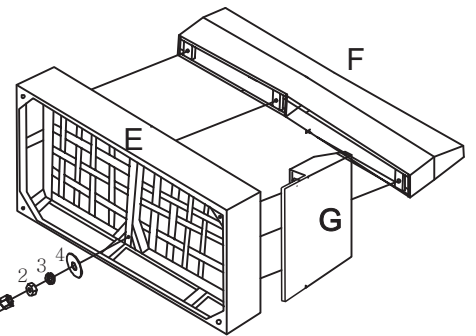
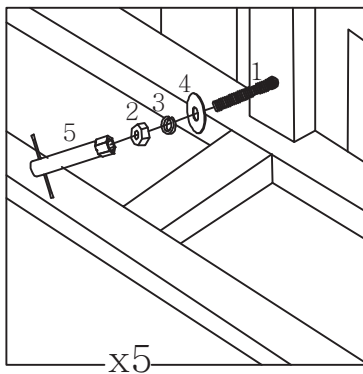

**STEP 3- PUT BACK THE FABRIC COVER AND INSERT LEGS**

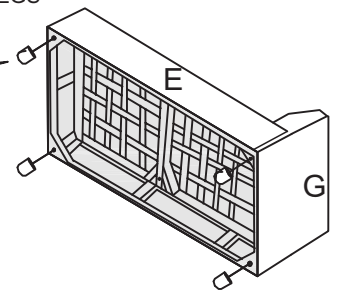
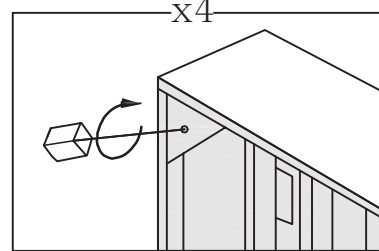

\*Stop when the rod starts coming out on the other end

## NOTICE BEFORE ASSEMBLY

Please choose the CHAISE to be on  
the LEFT or RIGHT hand side

Assembly InstructionII :CHAISE ON THE RIGHT

ITEM NO.:F6542,F6543,F6544

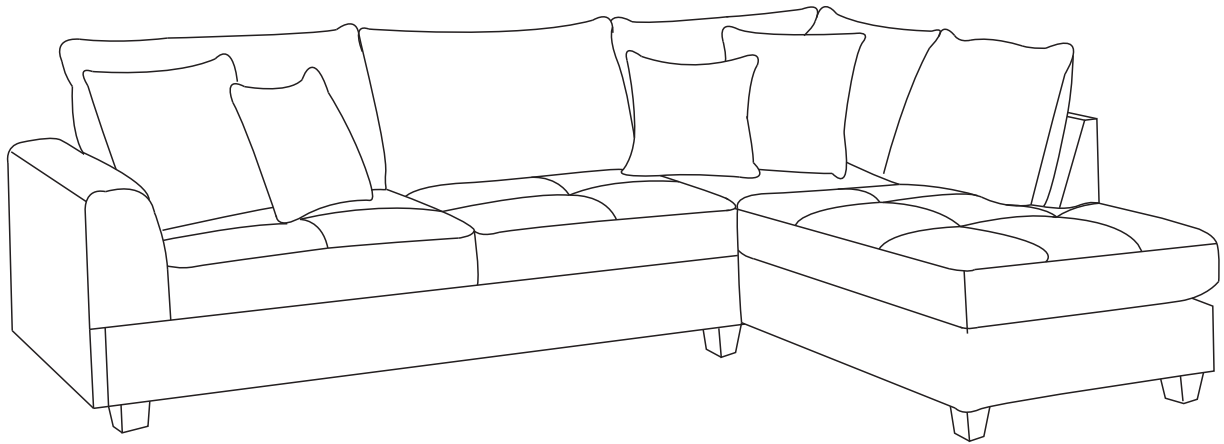

### PARTS LIST

BOX 1

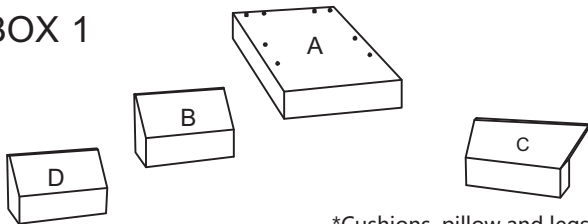

\*Cushions, pillow and legs included

BOX 2

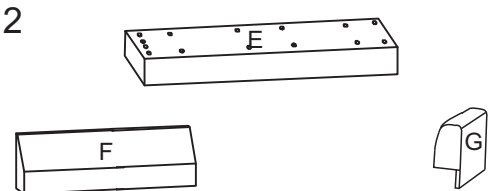

\*Cushions, pillow and legs included

1  x11

2  x11

3  x11

4  x11

5  x2

6  x8

### BEFORE ASSEMBLY

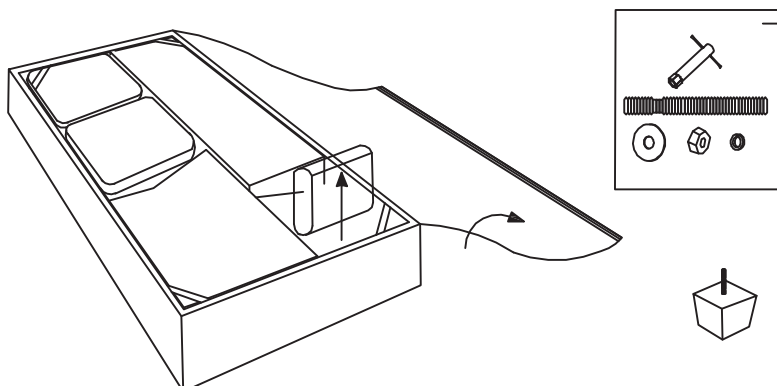

Open up the Velcro of Non-Woven Fabric cover on the bottom of the seat frame to remove seat cushions, back cushions and pillow

\*\*\*PLEASE REMOVE ALL PARTS FROM SEAT FRAMES AND SEAT BACKS BEFORE ASSEMBLY\*\*\*

CHAISE ON THE LEFT

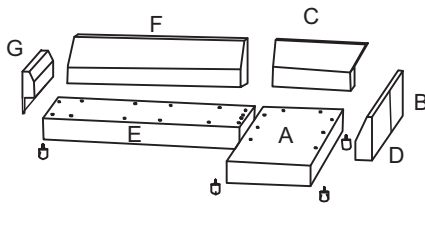

CHAISE BOX-1

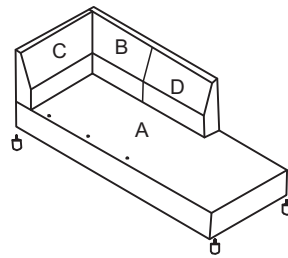

SOFA BOX-2

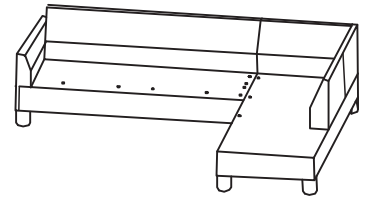
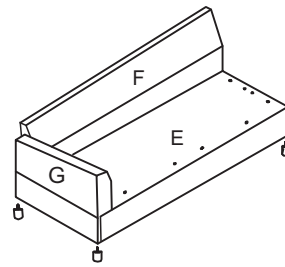

**CHAISE ASSEMBLY INSTRUCTION BOX-1**

**STEP 1 - INSERT THREADED ROD INTO SEAT BACKS**

\*Stop when the rod starts coming out on the other end

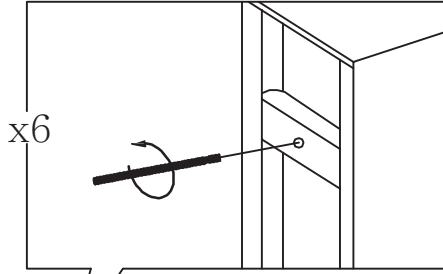

**STEP 2 - MOUNTED SEAT BACKS INTO THE SEAT FRAME**

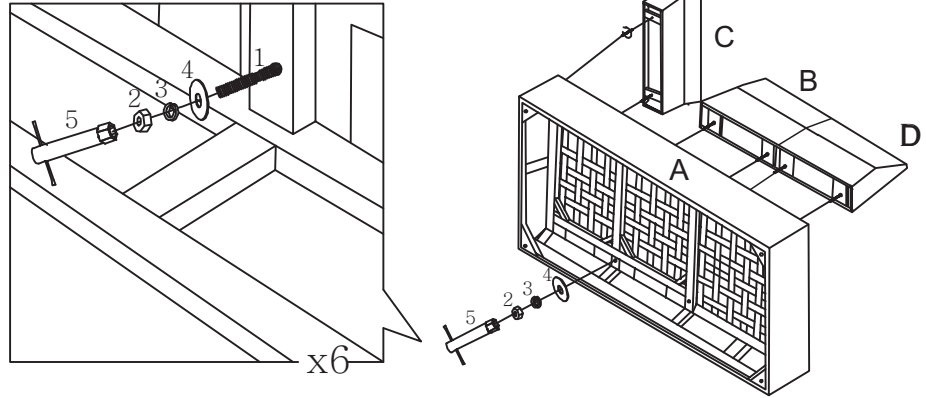

**STEP 3 - PUT BACK THE FABRIC COVER AND INSERT LEGS**

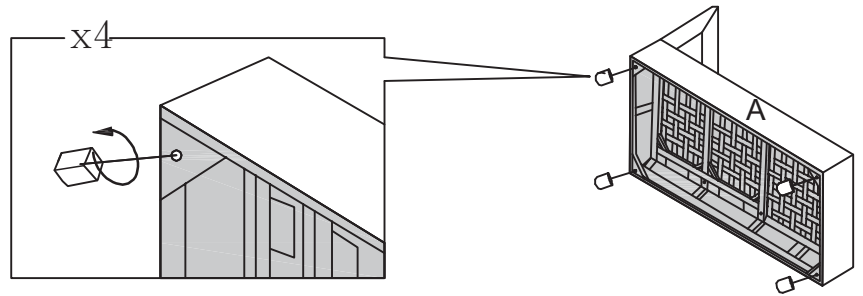
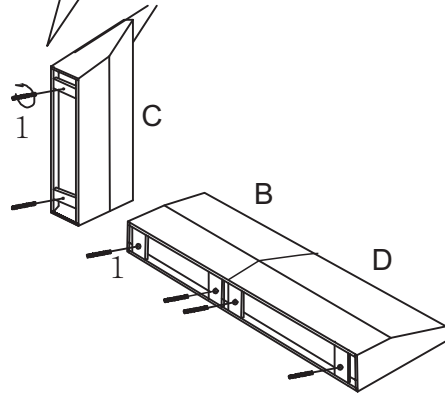

**SOFA ASSEMBLY INSTRUCTION BOX-2**

**STEP 1 - INSERT THREADED ROD INTO SEAT BACKS**

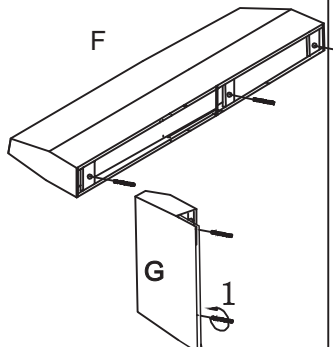

**STEP 2 - MOUNTED SEAT BACKS INTO THE SEAT FRAME**

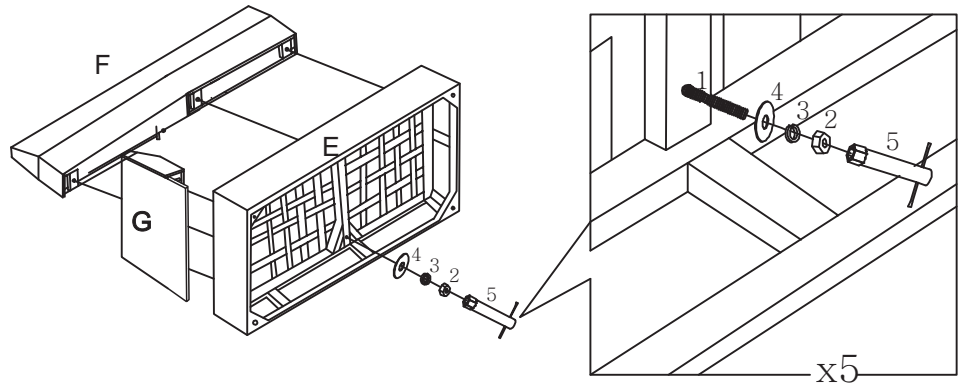

**STEP 3 - PUT BACK THE FABRIC COVER AND INSERT LEGS**

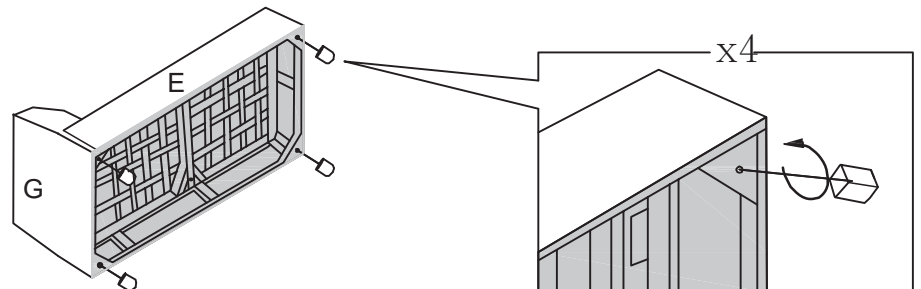
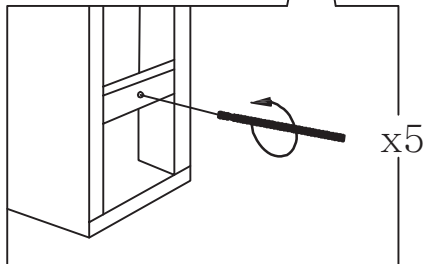

\*Stop when the rod starts coming out on the other end

## Assembly Instructions

ITEM NO.: F6542,F6543,F6544

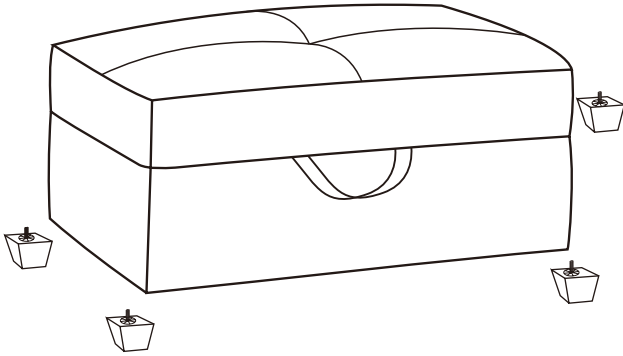

1

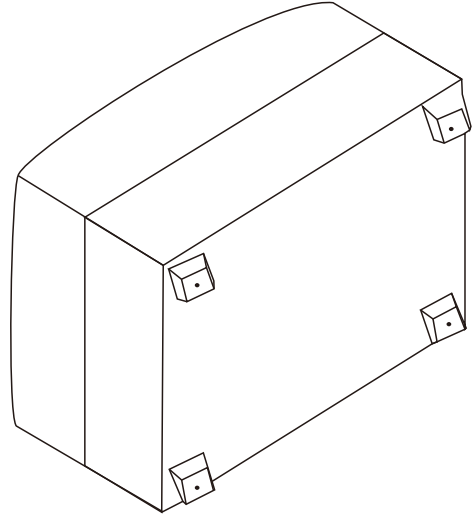

2

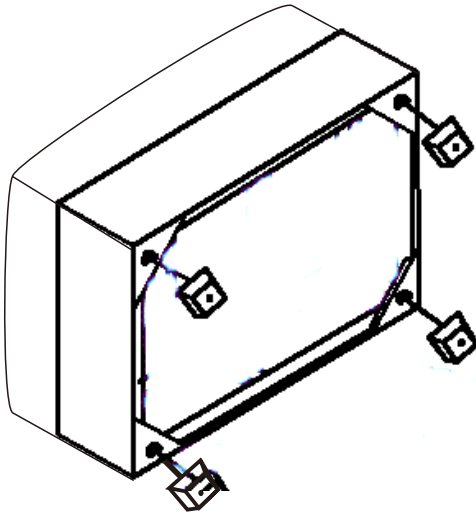

3

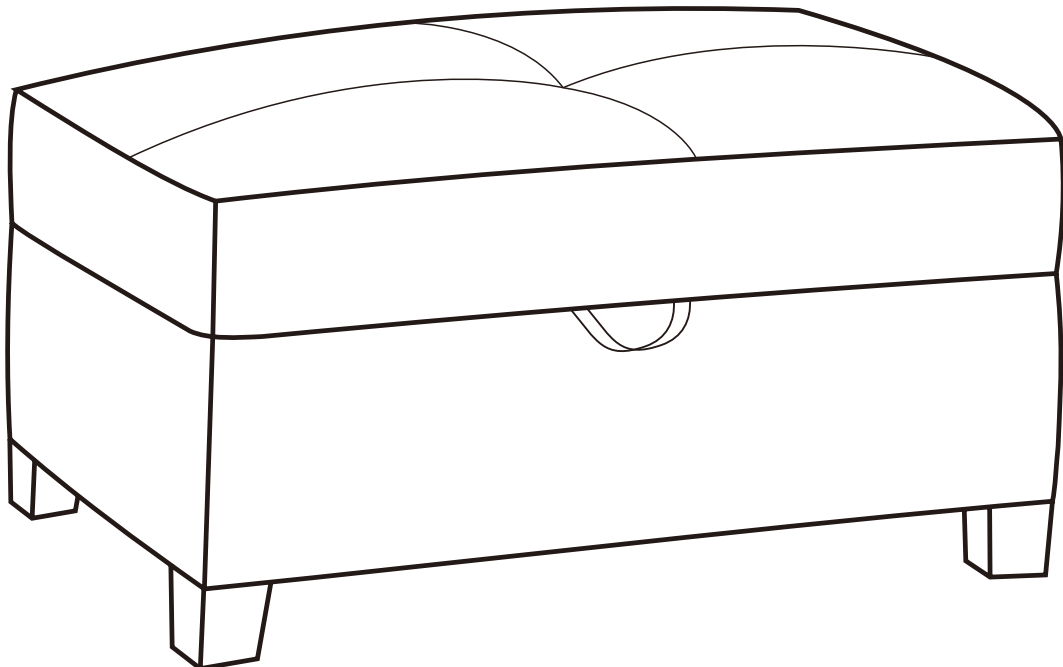
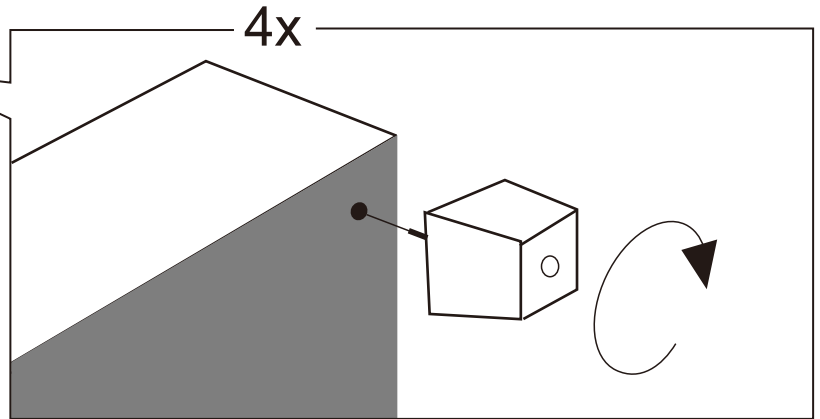

4

**INSERT THE “n” SHAPE HANGER INTO THE SEAT FRAME TO ATTACH THE SECTIONAL TOGETHER.**

