

Assembly Instructions

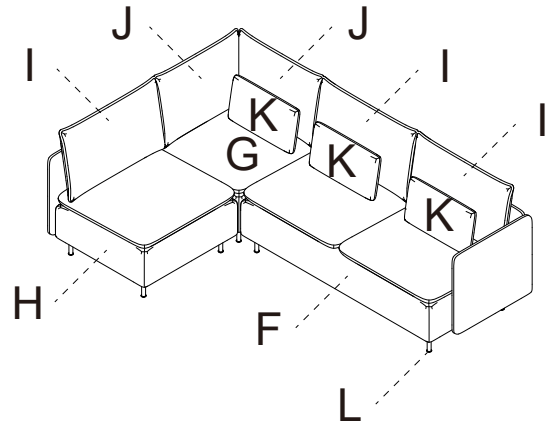

Assemble on the pad to prevent scratching the product.
Do not tighten all screws before instructions prompt.

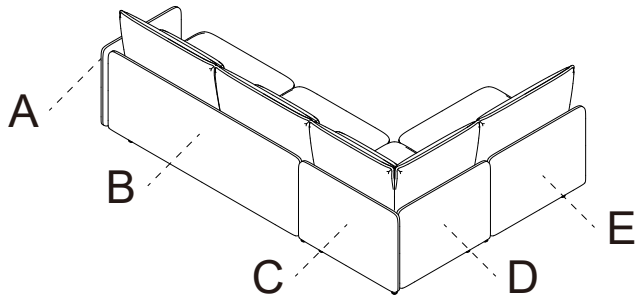

Parts List

Open the hardware check all parts QTY, thanks

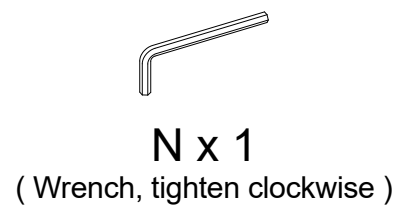
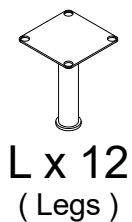
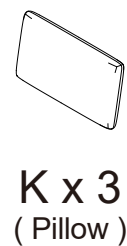
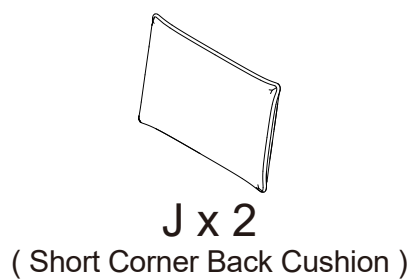
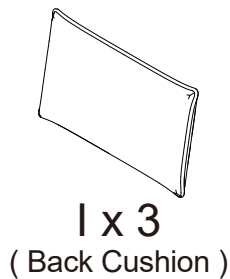
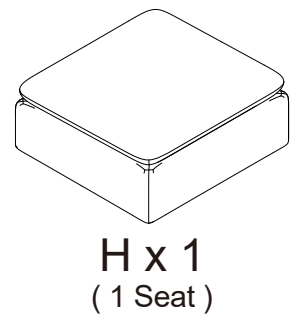
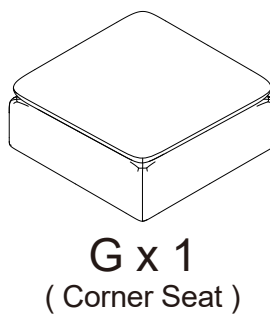
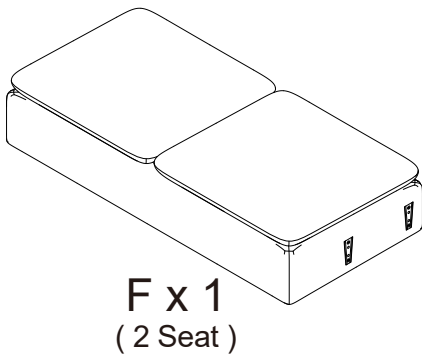
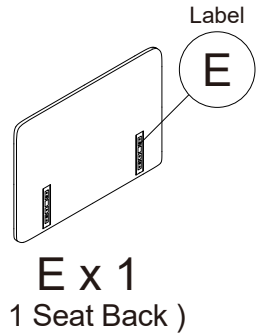
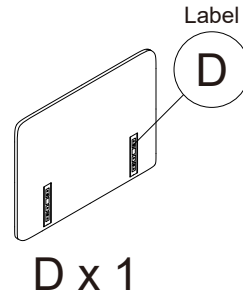
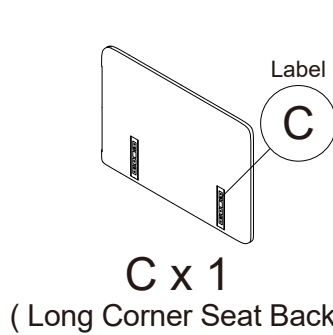
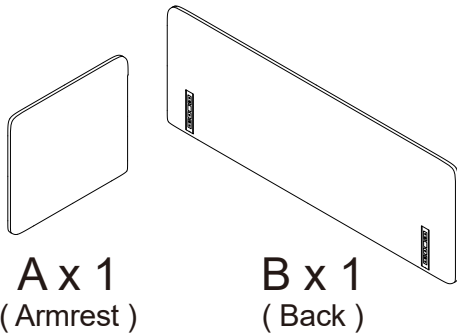

Step 1 Open the velcro on bottom of "F".
Take out "C", "D", "I", "K".

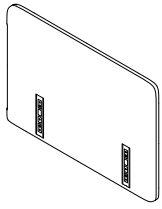

C x 1

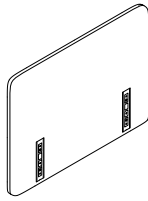

D x 1

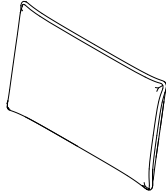

I x 2

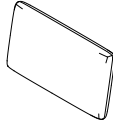

K x 2

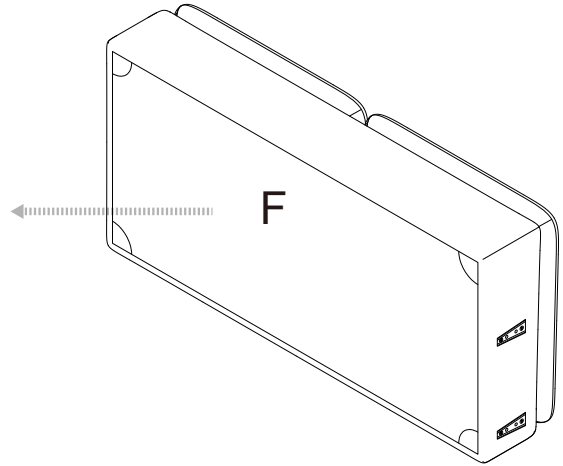

Step 2 Open the velcro on bottom of "G".
Take out "A", "J".

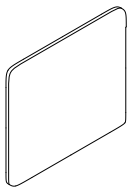

A x 1

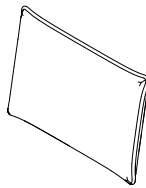

J x 2

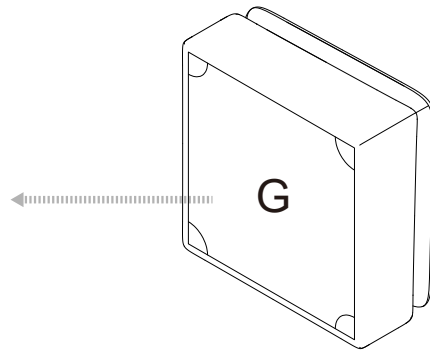

Step 3 Open the velcro on bottom of "H".
Take out "I", "K", "L", "M", "N".

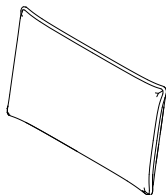

I x 1

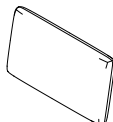

K x 1

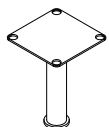

L x 12



M x 48



N x 1

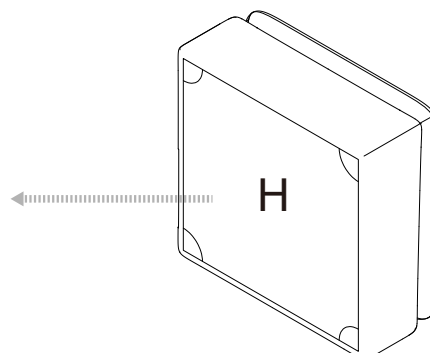

Step 4

First the four screws screwing in, then tighten clockwise.
Close the velcro on bottom of "F", "G", "H".

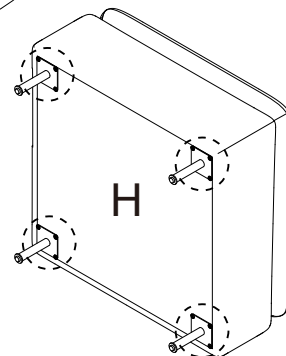
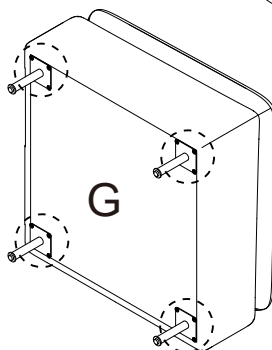
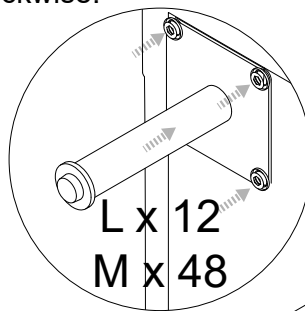
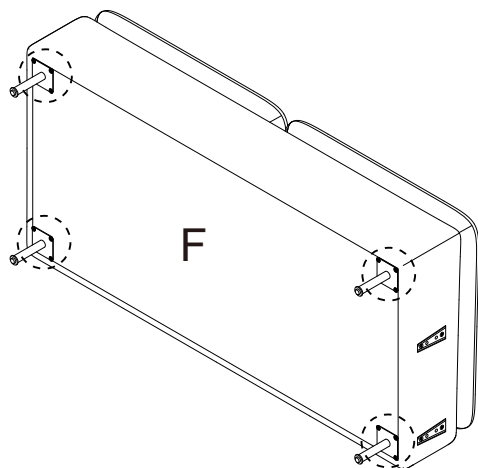

Step 5

Rotate out saw lock under velcro of "F" and "H".
Push "F" and "H" to "G".

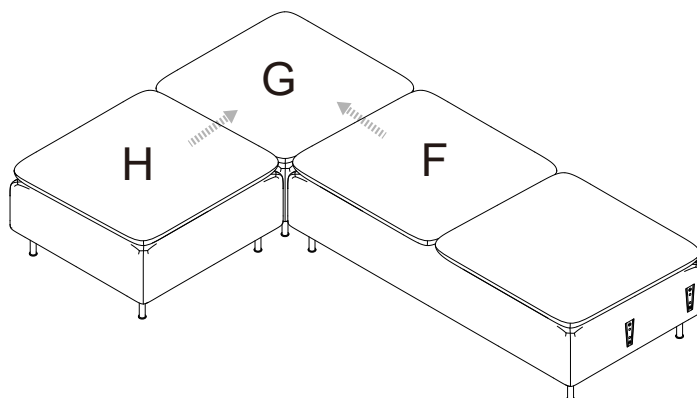
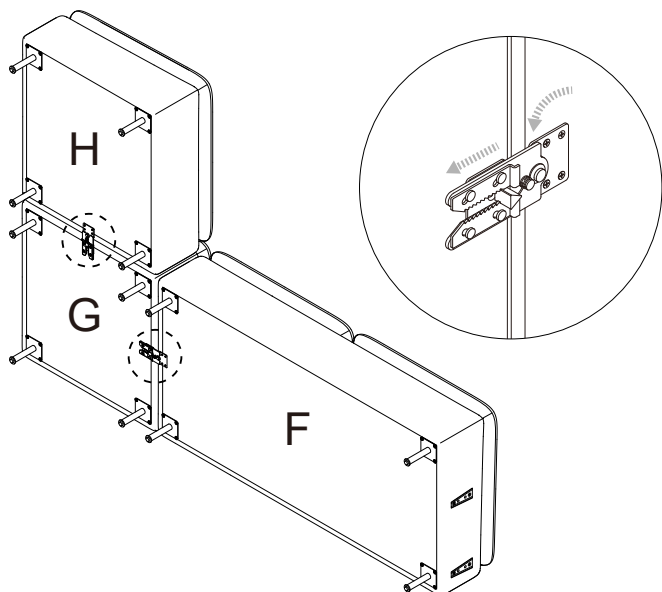

Step 6

Press "E" inserting pieces into "H" slots.
Press "D" inserting pieces into "G" slots.
Press "C" inserting pieces into "G" slots.
Press "B" inserting pieces into "F" slots.
Press "A" inserting pieces into "F" slots.
Place the "I", "J", "K".

