











HARDWARE LIST

- A (2) M6 x 40mm Allen Bolts
- B (8) M6 x 35mm Allen Bolts
- C (10) M3.5 x 32 Wood Screws
- D (8) M8 x 20mm Allen Bolts
- E (4) M6 x 50 Allen Bolts
- F (1) M4 x 100 Allen Wrench
- G (1) M5 x 65 Allen Wrench
- H (16) Flat Washers
- I (16) Spring Washers
- J (2) Wood Dowels

PART	QTY	HARDWARE	PART	QTY	HARDWARE
A	2		B	8	
C	10		D	8	
E	4		F	1	
G	1		H	16	
I	16		J	2	

PARTS LIST

- K (1) Footboard
- L (2) Left Side Rails
- M (2) Right Side Rails
- N (2) Rail Supports
- O (2) Feet
- P (13) Slats
- Q (2) Cross Bars
- R (4) Cross Bar Supports

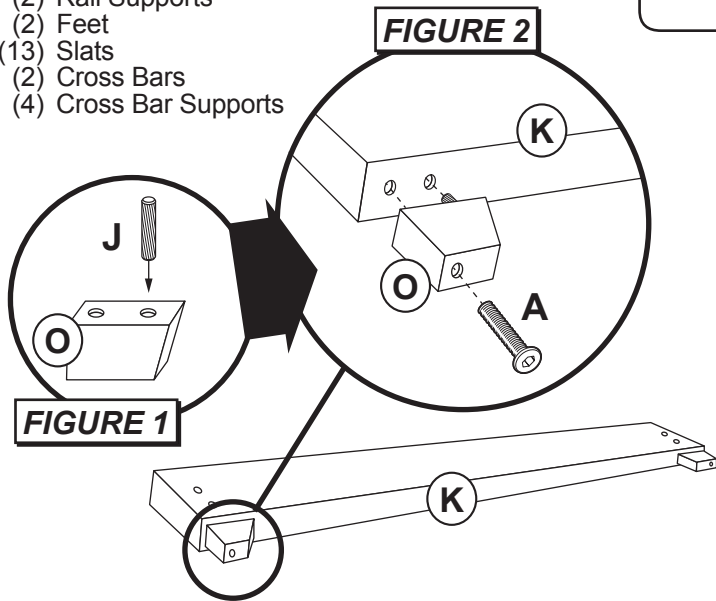

STEP 1 - Figure 1

Begin assembly by inserting 1 Wood Dowel (J) into each Foot (O) on the angled side. Lightly hammer dowels to make sure they are in tightly (hammer not included).

STEP 2 - Figure 2

Next attach Feet (O) to Footboard (K) by inserting the dowel in the inside hole and securing with 1 Allen Bolt (A) per foot. Tighten bolts with Allen Wrench (F) provided.

STEP 3 - Figure 3

Line up each set of Left (L) and Right (M) Side Rails to each other and secure them together with the Rail Supports (N) using 4 Allen Bolts (B), 4 Spring Washers (I) and 4 Flat Washers (H). Tighten all bolts with Allen Wrench (F) provided.

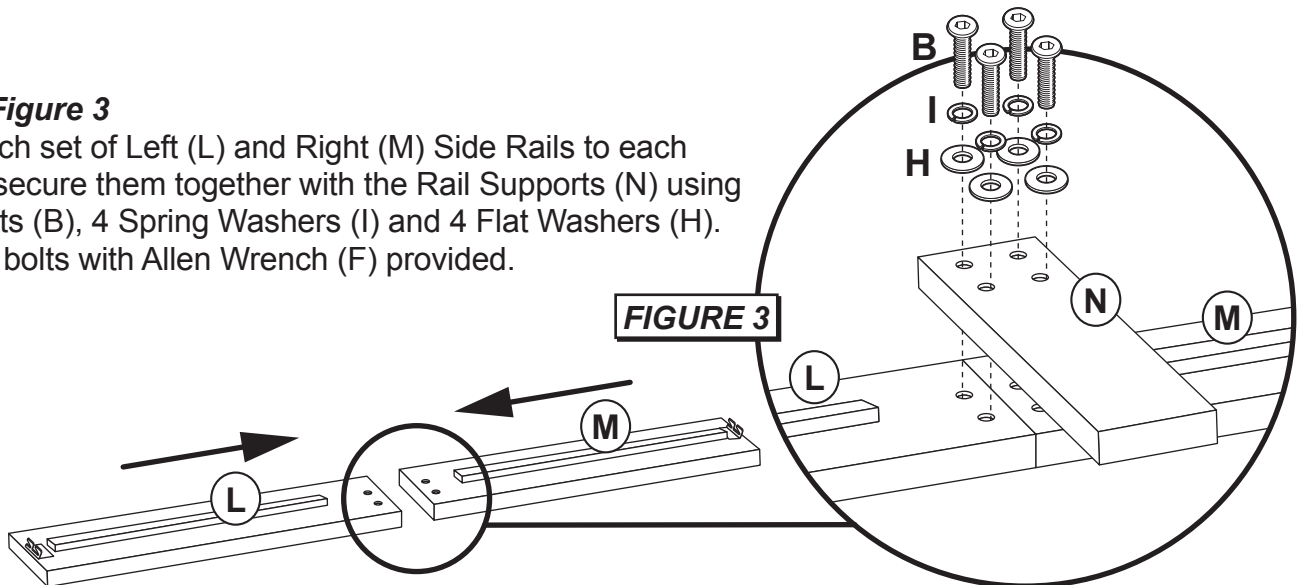

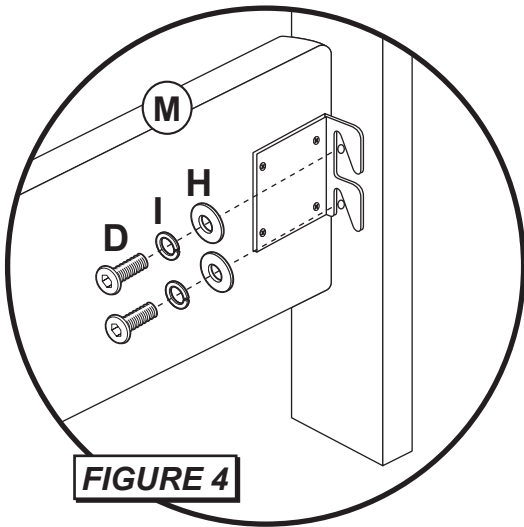
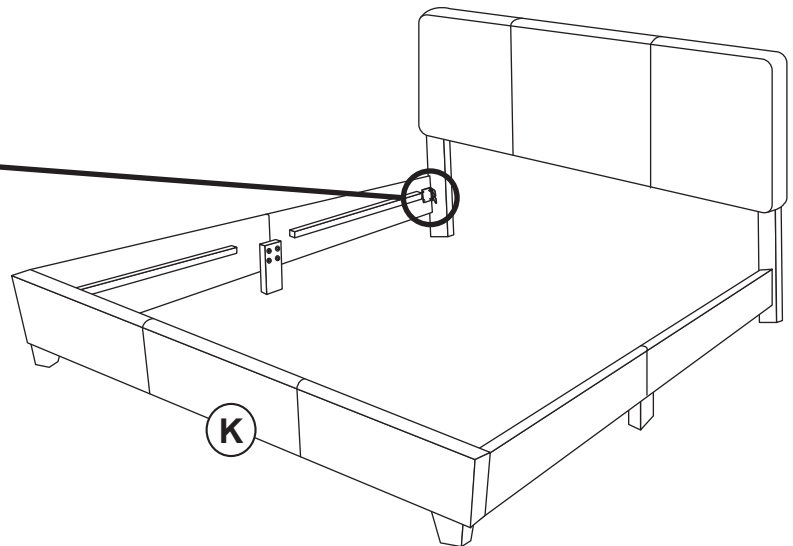

FIGURE 4



STEP 4 - Figure 4

Attach Side Rails (L & M) to Headboard and Footboard (K) using 2 Allen Bolts (D), 2 Spring Washers (I) and 2 Flat Washers (H) per side. Tighten all bolts with Allen Wrench (G) provided.

STEP 5 - Figure 5

Attach center Slat (P) to Rail Supports (N) using 1 Wood Screw (C) per side. Tighten screws with Phillips head screwdriver (not included).

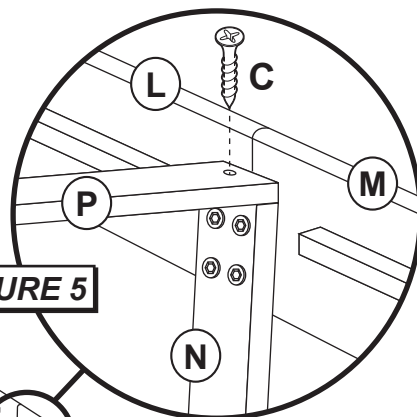
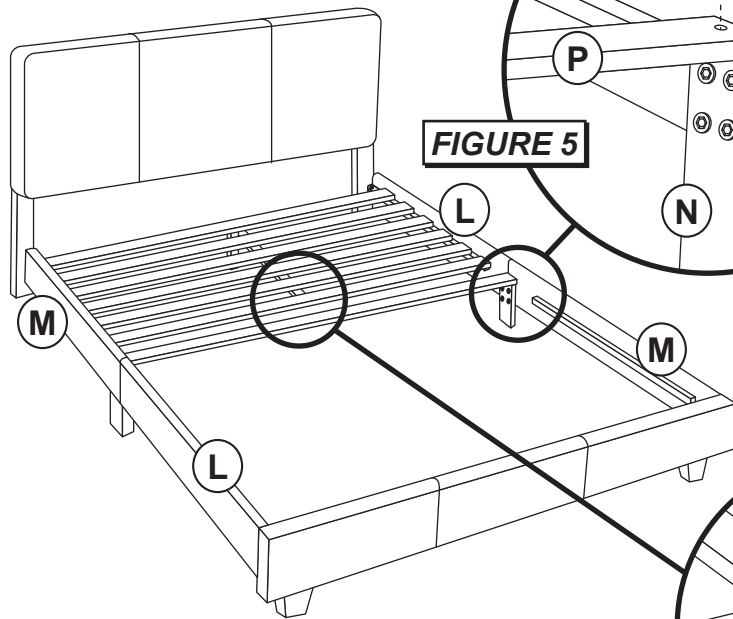

FIGURE 5



STEP 6 - Figure 6

Attach 2 Cross Bars (Q) to 4 Cross Bar Supports (R) securing through Slats (P) with Allen Bolts (E). Tighten all bolts with Allen Wrench (F) provided. The assembly is now complete.

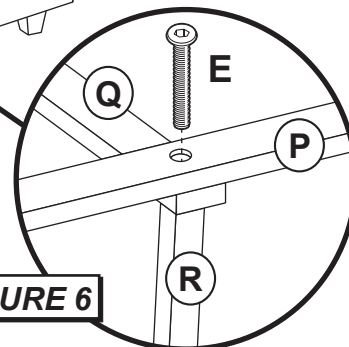

FIGURE 6