



CEILING FAN NO LIGHT
INSTALLATION MANUAL

SAFTY RULES

1. To reduce the risk of electric shock, insure electricity has been turned off at the circuit breaker or fuse box before beginning.
2. All wiring must be in accordance with the National Electrical Code and local electrical codes. Electrical installation should be performed by a qualified licensed electrician.
3. **WARNING:** To reduce the risk of electrical shock and fire, do not use this fan with any solid-state fan speed control device.
4. **WARNING:** To reduce the risk of fire, electric shock, or personal injury, mount to outlet box marked "Acceptable for Fan Support of 45kg (99.12 lbs.) Or Less" and use mounting screws provided with the outlet box. Most outlet boxes commonly used for the support of light fixtures are not acceptable for fan support and may need to be replaced. Due to the complexity of the installation of this fan, a qualified licensed electrician is strongly recommended.
5. The outlet box and support structure must be securely mounted and capable of reliably supporting a minimum of 45KGS. Use only UL Listed outlet boxes marked FOR FAN SUPPORT.
6. The fan must be mounted with a minimum of 7 feet clearance from the trailing edge of the blades to the floor.
7. Avoid placing objects in the path of the blades.
8. To avoid personal injury or damage to the fan and other items, be cautious when working around or cleaning the fan.
9. Do not use water or detergents when cleaning the fan or fan blades. A dry dust cloth or lightly dampened cloth will be suitable for most cleaning.
10. After making electrical connections, spliced conductors should be turned upward and pushed carefully up into the outlet box. The wires should be spread apart with the grounded conductor and the equipment-grounding conductor on one side of the outlet box.
11. Electrical diagrams are for reference only.
12. The fan is suitable for indoor use only.

TOOLS REQUIRED





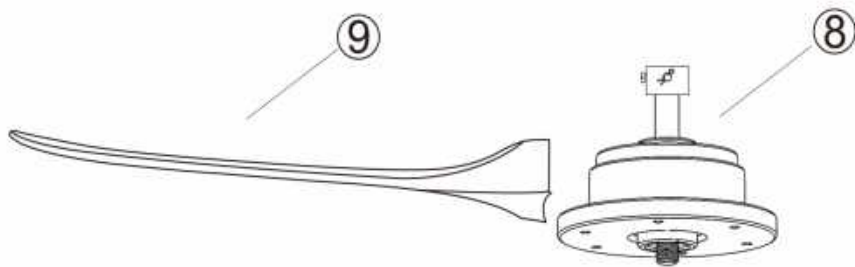
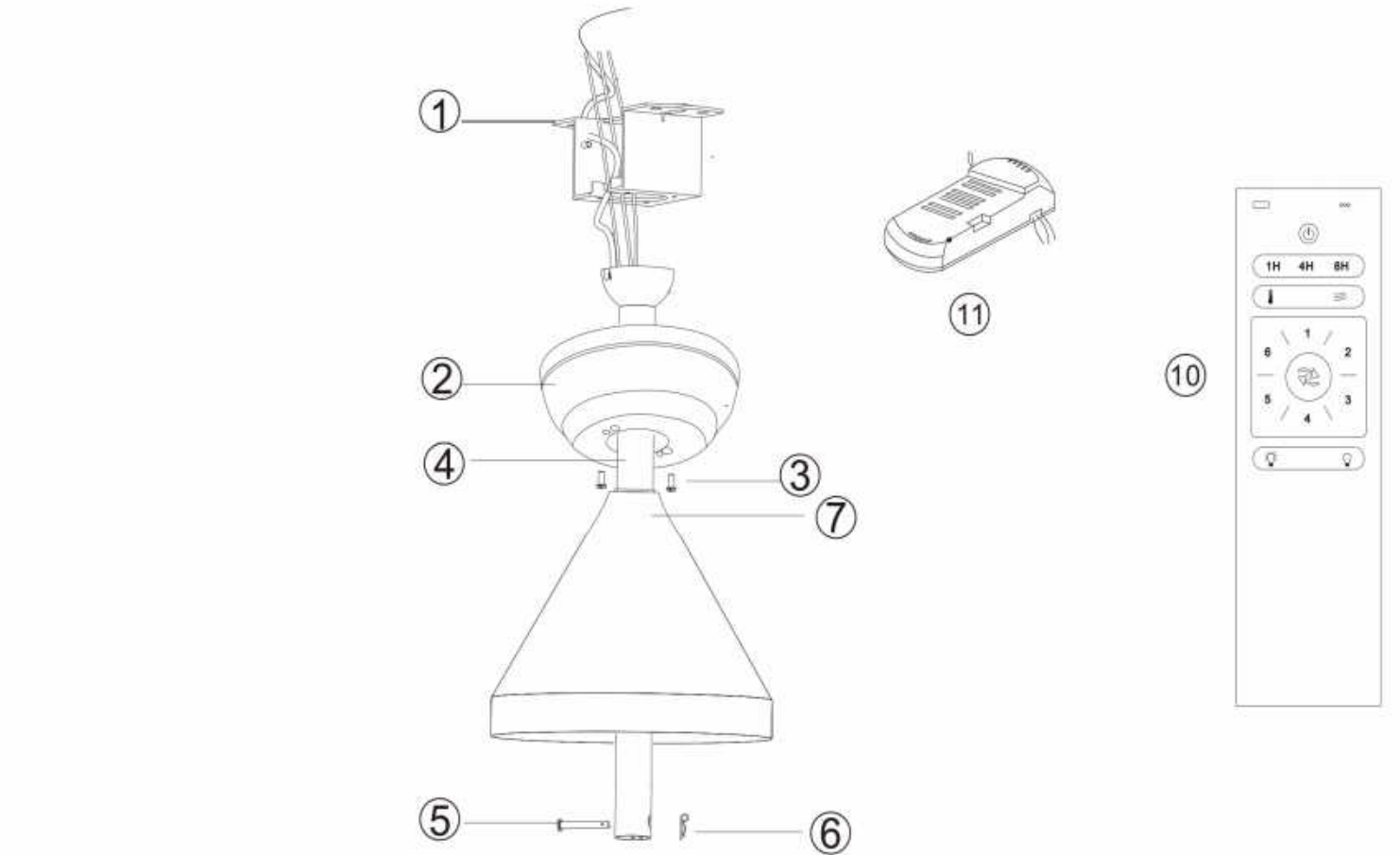

BEFORE INSTALLATION

Unpack your fan and check the contents. You should have followings:

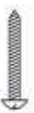

- 1. Mounting Bracket X 1
- 2. Canopy X 1
- 3. Canopy Screws X 2
- 4. Downrod (Short rod 12.5cm) X1
(Long pole 25cm) X1
- 5. Bolt X 1
- 6. Bolt X 1
- 7. Pin Cover X 1
- 8. DC Motor X 1
- 9. Blade X 3
- 10. Remote Control X 1
- 11. Remote Receiver X 1

Note: the remote receiver must match the same code control

							
Explosion screw	4	Balance sticker	2	Self-tapping screws	4	1/4*15mm	6

INSTALLING THE FAN

Tools Required: Phillips Screwdriver, Pair of Pliers, Straight slot screwdriver, Adjustable Wrench, Step Ladder and Wire Cutters.

INSTALL THE MOUNTING BRACKET

To prevent personal injury and damage, ensure that the hanging location allows the blade a clearance of 7.5 feet (2.3 metets) from the floor and 18 inches (45.72 centimeters) from any wall or obstruction.

1. For the concrete ceiling: Mark the location for the ceiling fan first, then drill two holes in the ceiling to aid in securing ceiling bracket with two expansion screws provided, and secure the mounting bracket to the building structure with two expansion screws provided, tighten the screws. (Fig.1)

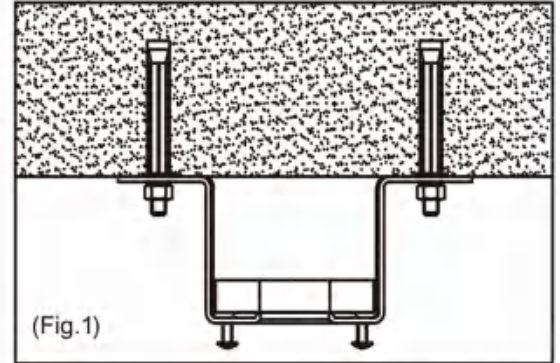

2. For the Wood Ceiling: Mark the location for the ceiling fan first, secure the mounting bracket to the building structure with four wood screws provided. (Fig.2)

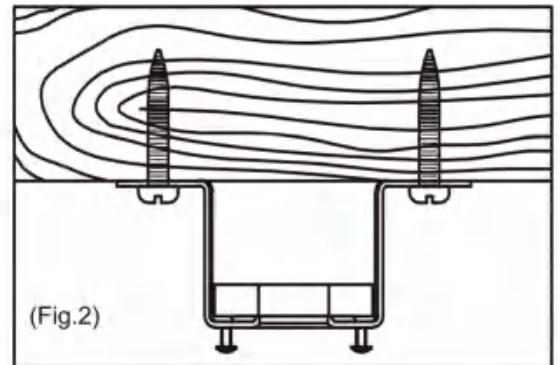

NOTE: Hanger after the installation must be able to withstand the weight of 45 kgs or more.

INSTALL THE BLADE

Insert the blade onto the motor and align the screw holes to lock it in place.

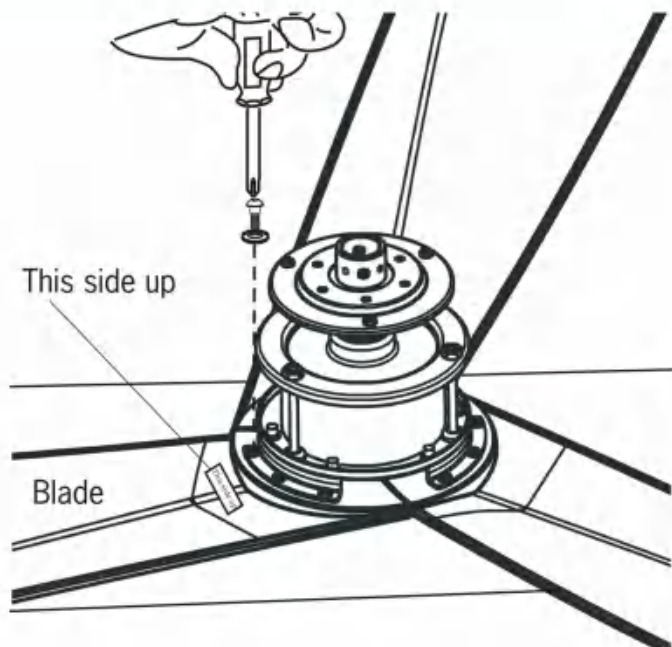

ASSEMBLY OF DOWNROD

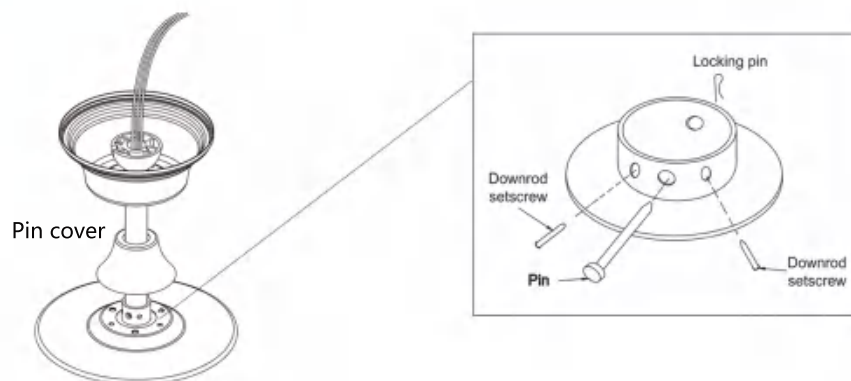

Choose the proper downrod

1. Put the downrod through the top canopy and the downrod canopy
2. Pass the wire from the motor body through the downrod
3. Secure the downrod and motor body with downrod setscrews and celvis pin

CHANGE DOWNROD (OPT)

The Ceiling Fan comes with one 5 inches standard downrod which is preassembled and attached to the hanger ball, one longer 10 inches downrod is also included for higher ceilings.

If you need a different downrod length, please follow these steps:

1. Loosen the hanger ball from downrod by removing set screw.
2. Slide downrod ball off of downrod and remove pin
3. Re-install pin into extended downrod, and slide downrod ball up to the top of the downrod
4. Re-install set screw to secure ball to downrod

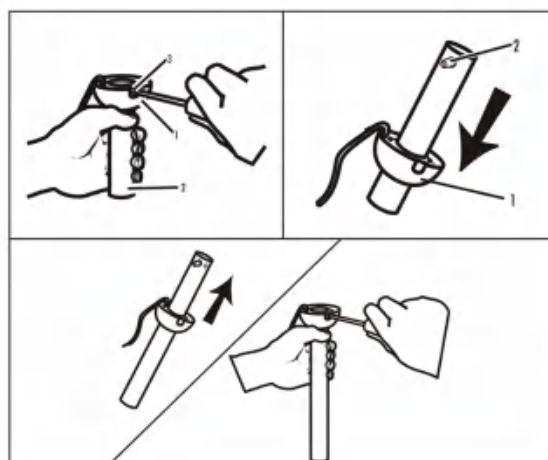

MOUNT FAN TO BRACKET

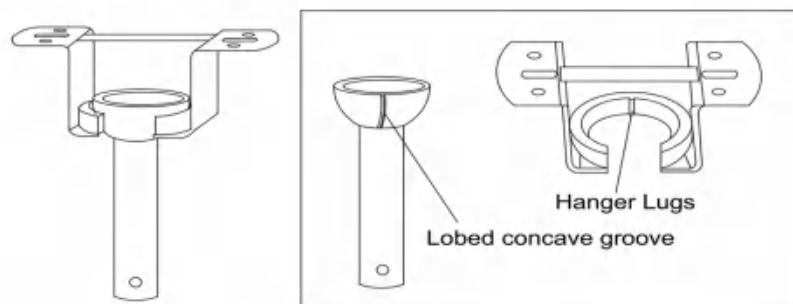

Lift the fan assembly onto the mounting bracket. Ensure the registration slot of the hanger ball is positioned on the stopper of the mounting bracket to prevent the fan from rotating when in operation.

Tips:

Seek the help of another person to hold the stepladder and hang the fan body for you.

INSTALL THE REMOTE CONTROL

Make wiring connections from the house and the motor to the remote receiver as shown right.

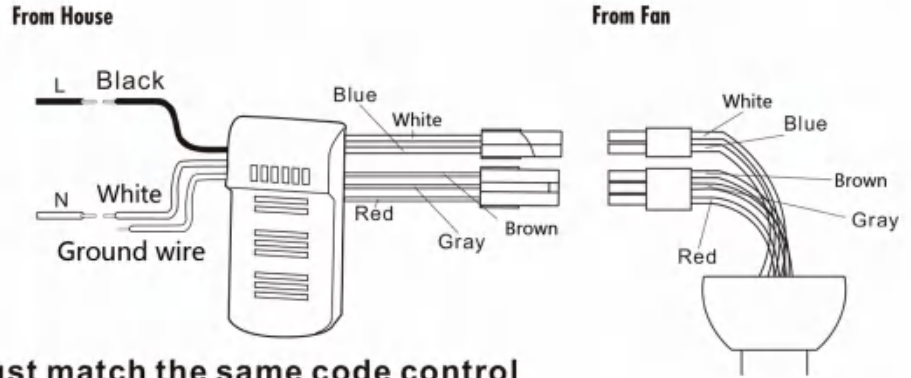

Note: the remote receiver must match the same code control

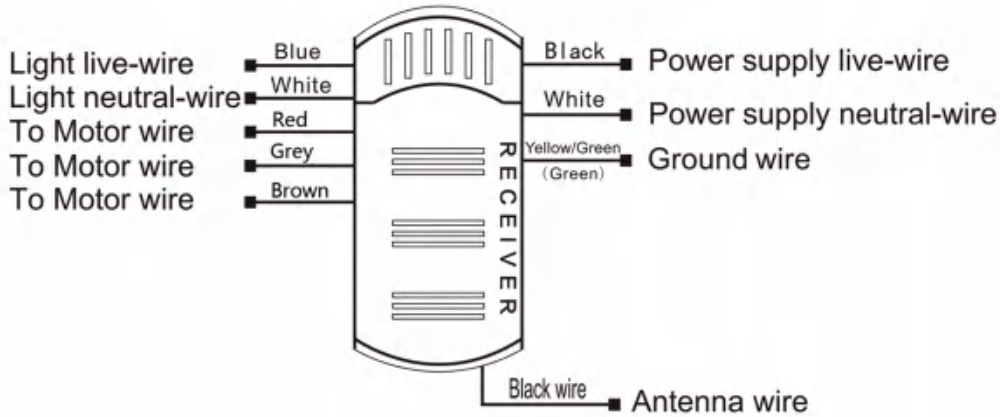

Note: the remote receiver must match the same code control

Insert the receiver into the top of the fan body and make wire connections according to wire colors, labels, and diagram above.

- * Wrap each wire connector separately with electrical tape as an extra safety measure.
- * After wiring finished, leave the receiver in the bracket and secure it with the electrical tape then secure the canopy to the bracket

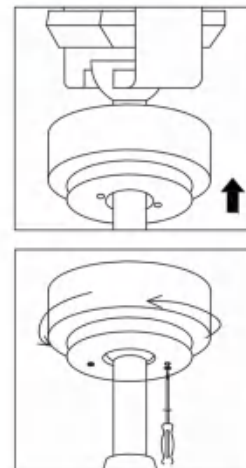
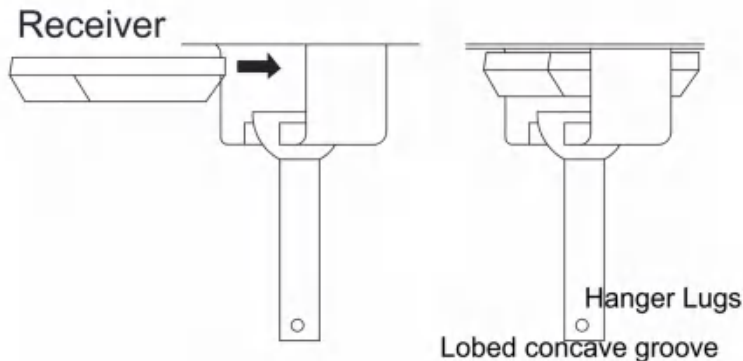

USE OF REMOTE CONTROL

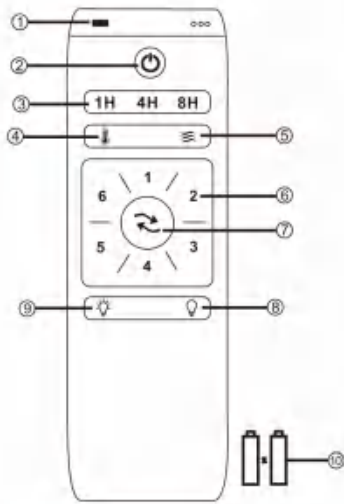

- ① LED indicated light
- ② Turn off the fan
- ③ Timing control of the fan
- ④ Optional: Anti-theft function(Press hold for 3 seconds to turn on this function)
(the light ON about 5~20 minutes every 2 hours)
- ⑤ Natural wind
- ⑥ Speed of the fan
- ⑦ Direction of the fan (reverse switch)
- ⑧ Turn off the light
- ⑨ Turn on the light
- ⑩ 1.5V AAA battery X 2pcs This product does not contain batteries

1. Learning code matching mode is used between emitter and receiver. Turn "ON" the supply power within 30 seconds and press the emitter's " ⏻ " button for 5 seconds, it can load normally after hearing a long sound "bee", which means learning successfully and it can works normally. (PS: Learning mode is not accepted after turn "ON" the supply power for 30 seconds)
2. When the emitter cannot control the receiver, please check the battery switch touching normally or not, correction of the positive and negative, full or empty of the power.
3. When the emitter cannot control the receiver, please check is there any existence of similar remote controlled products nearby, then check whether they works, because remote controlled product with the same frequency will disturb each other.
4. Low voltage of battery will affect the sensitivity of the emitter and the signal reception accordingly (the indicated light will flash out its warning when the battery get low voltage), must replace if the battery is getting low voltage.
5. Please take out the battery from the emitter when leaving unused for long time.
6. The maximum load of lighting see the above "POWER PARAMETER LIST"
PS: please connect the ground wire correctly, otherwise it may cause the light micro-light or flash
7. **When installing the fan, the fan ceiling cover don't press the antenna (or other wire), it is easy to breakdown the wire and short-circuited.**

Fan will not start:

1. Check circuit fuses or breakers.
2. Check line wire connections to the fan and switch wire connections in the switch housing. CAUTION: Make sure main power is off.
3. After the fan is powered on, pressing the remote control does not respond, and the fan beeps. Please do not press the remote control multiple times, Please turn off the power immediately, And check whether the wire between the motor and the receiver is loose. Or remove and re install.

Fan sounds noisy:

1. Make sure all motor housingscrews are snug.
2. Make sure the screws that attach the fan blade bracket to the motor hub are tight.
3. Make sure wire nut connections are not rubbing against each other or the interior wall of the switch housing. CAUTION: Make sure main power is off.
4. Allow a 24-hour "breaking-in" period. Most noises associated with a new fan disappear during this time.
5. If using an optional light kit, make sure the screws securing the glassware are tight. Check that light bulb is also secure.
6. Some fan motors are sensitive to signals from solid-state variable speed controls. If you have installed this type of control, choose and install another type of control.
7. Make sure the upper canopy is a short distance from the ceiling. It should not touch the ceiling.
8. If the above method still does not solve the problem, please contact the manufacturer.

WARRANTY CLAIMS

- There is a 30-day warranty for broken furniture or any other problems that do not work properly. The warranty will start from the date of purchase which must be verified by proof of purchase.
- Before making a claim, we may be able to answer your query, simply call us. Please leave your purchase order number, along with some details of the problem, if you want a replacement part. We will arrange within 48 hours. If there is out of stock, we will reply with a shipping date.
- The product must be used in accordance with the instructions provided. For health reasons.
- For other reasons, if the furniture needs to be returned, it must be cleaned and dried and operated within 30 days of receipt.

Type of Warranty Claim

- Failure to follow the furniture instructions will invalidate the warranty. Attention please.
- Does not include damage during installation, but includes damage during transportation.

Scope of responsibility

- Shall not bear any responsibility for misuse or user damage and / or loss of parts during the installation of furniture.
- After using, the damage and scratches of the furniture are not covered by the warranty.

The Warranty Relates to All Bought in The Us and Covers The Following Areas

- Sheet parts: 1 month from the date of purchase.
- Electrical parts: 1 month from the date of purchase.

CHANGED YOUR MIND AND NEED TO RETURN YOU ITEM?

PLEASE FOLLOW THE BELOW INSTRUCTIONS:

- If you have purchased and have simply changed your mind, follow the retailer's instructions for returns.

DEFECTIVE ITEMS

- If your item is defective in any way, i.e. it doesn't work but you can't identify why, in the first instance, please call us.

DAMAGED ITEMS

- If you receive an order with obvious shipping damage from the retailer, then we suggest the delivery is refused. If the delivery has been accepted and then shipping damage is found, please follow the specific instructions advised by the retailer. In all circumstances please save all packaging material and paperwork for the order. Please be aware that if you dispose of packaging material or attempt to return the merchandise without contacting the fulfiller, you jeopardise your chances of making a claim, and you may not receive a credit for the return.