

# Assembly Guide

## Tip!

Do check for all the components and screws listed in this guide before putting things together. If any part is missing, for the missing part.

## Return Policy

Your satisfaction is our top priority. If our product fails to satisfy you, please let us know how we can make things right for you. Our trained customer care team can handle most concerns and assist you with any questions you may have. Simply shoot them a message at with your orde number and question. To be eligible for a full-refund return, the item must be in pristine condition, in the original packaging, with all of the shipped components intact and not yet assembled, and with the item's unique proof of purchase.



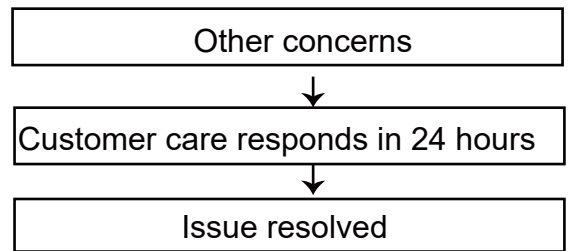
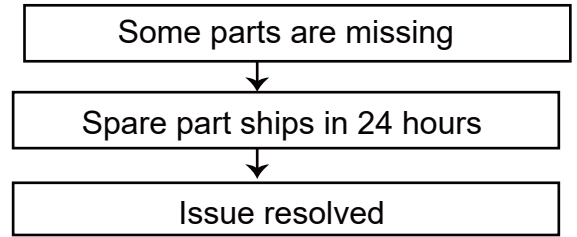



## Trouble shooting:



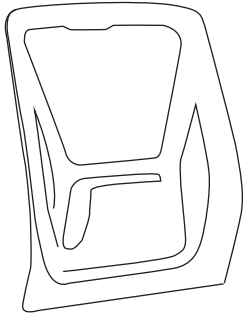

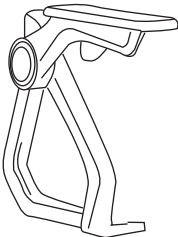
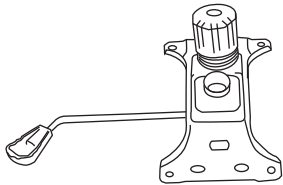
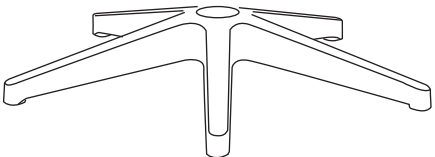
We run our own manufacturer, so rest assured about the quality consistency.



Item Description: Chair

<p><b>A</b></p>		<p>1pcs</p>	<p><b>B</b></p>		<p>1pcs</p>
<p><b>C</b></p>		<p>2pcs</p>	<p><b>D</b></p>		<p>1pcs</p>
<p><b>E</b></p>		<p>1pcs</p>	<p><b>F</b></p>		<p>5pcs</p>
<p><b>G</b></p>		<p>1pcs</p>	<p><b>H</b></p>		<p>1pcs</p>

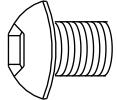
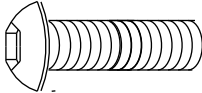
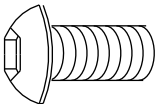
Screws & Tools / Schrauben und Werkzeuge / Vis et outils / Viti e utensili / Tornillos y Herramientas / 

<p><b>I1</b></p>	 <p>M6*20mm</p>	<p>4pcs</p>	<p><b>I2</b></p>	 <p>M6*30mm</p>	<p>4pcs</p>
<p><b>I3</b></p>	 <p>M6*25mm</p>	<p>4pcs</p>	<p><b>J</b></p>		<p>4pcs</p>

## Step 1

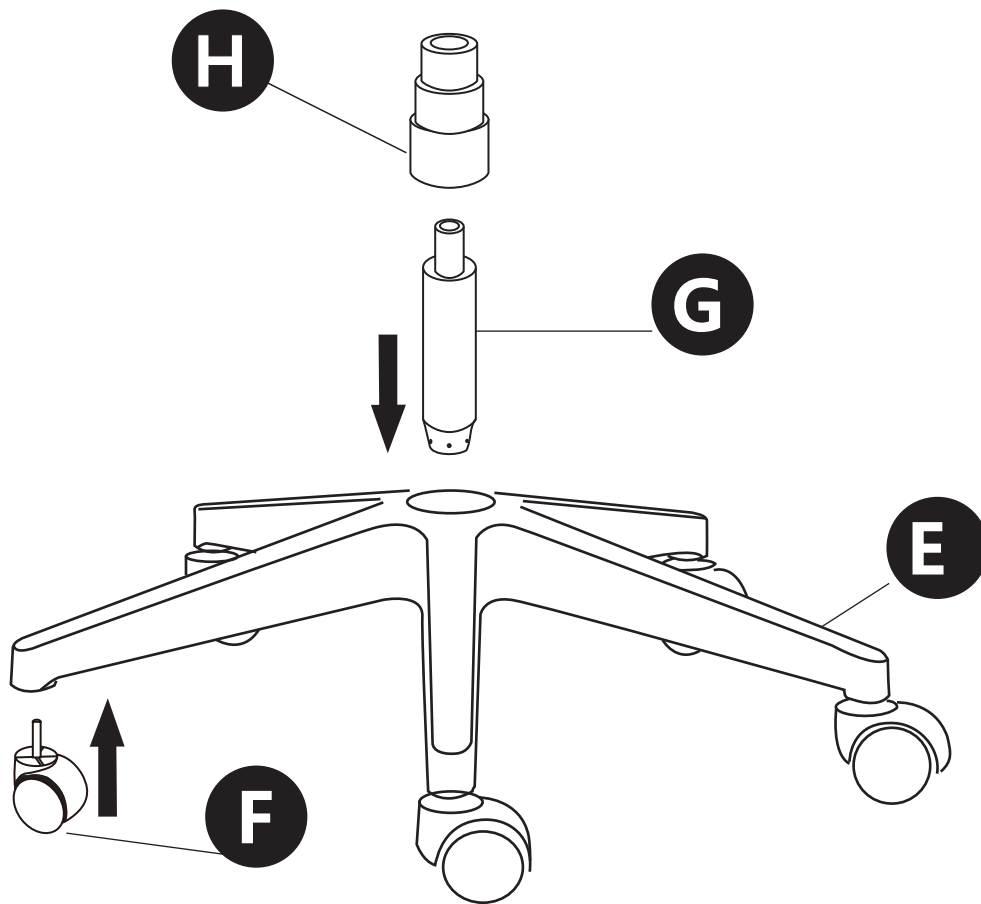

## Step 2

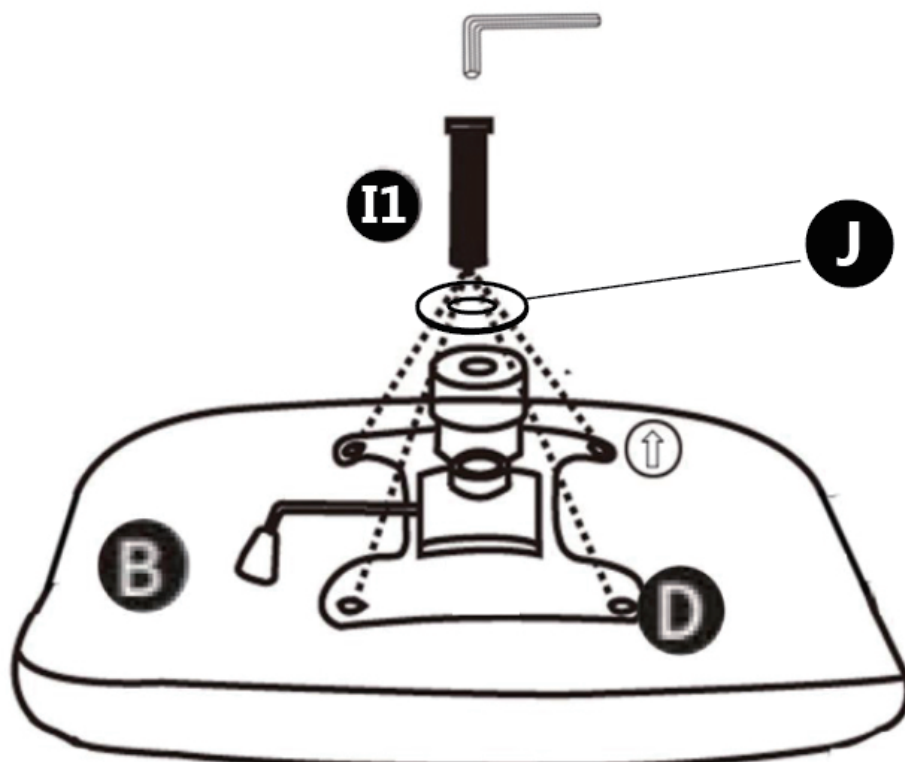
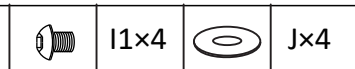

# Step 3

 12x4

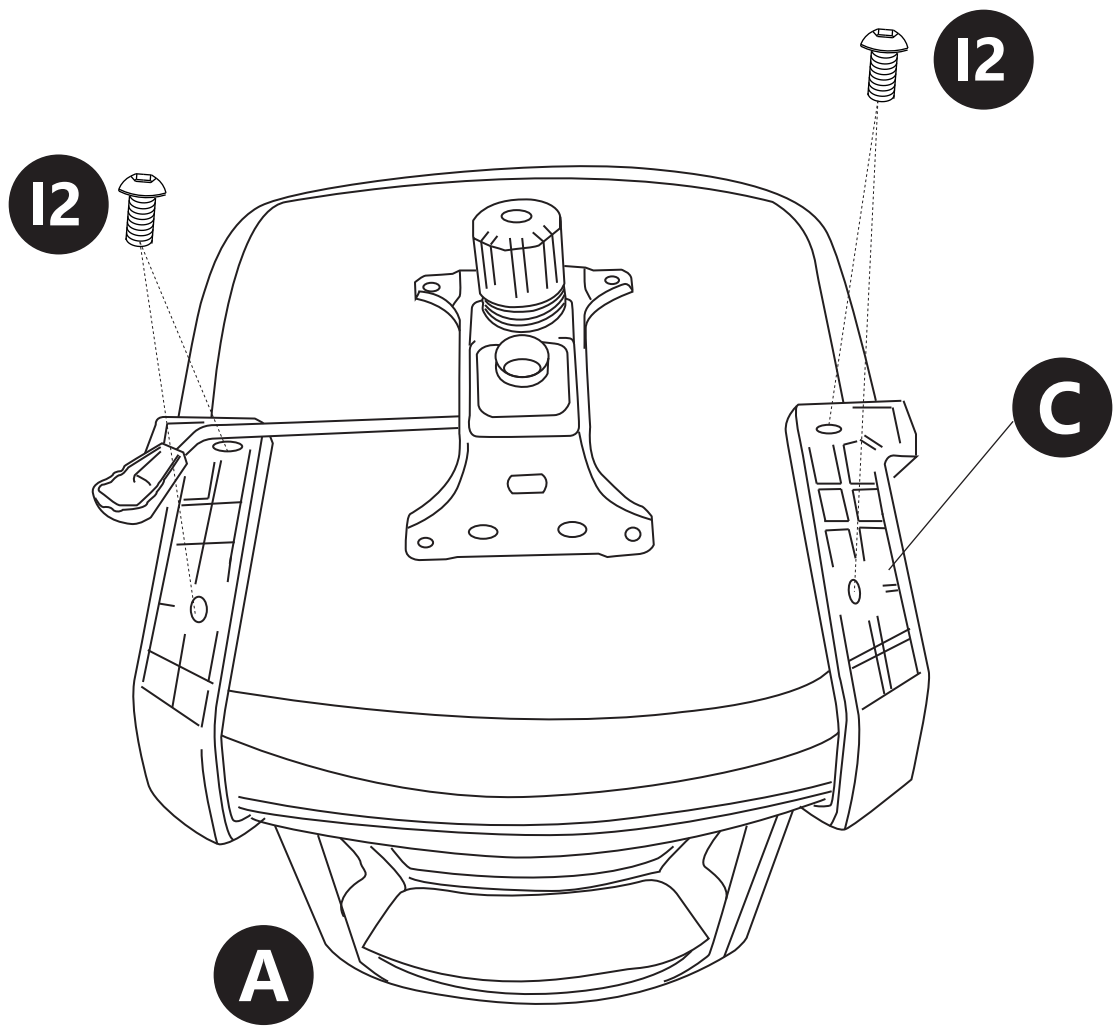

# Step 4



13x4

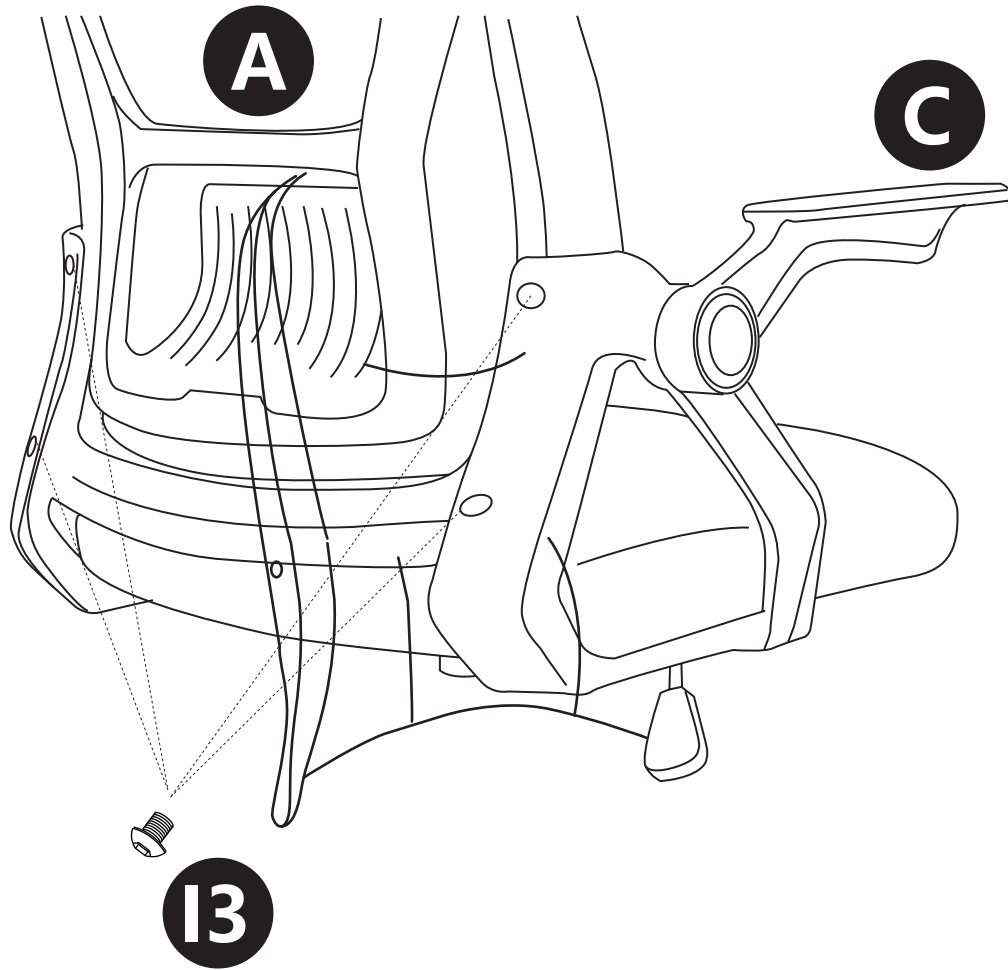

# Step 5

