







ASSEMBLY INSTRUCTION

317-746TL/M 60" Rectangular Table Top
 317-746BL/M 60" Trestle Table Base
 317-747TL/M 80" Rectangular Table Top
 317-747BL/M 80" Trestle Table Base

HARDWARE LIST				
A		Threaded Bolt	Ø5/16"*4"	2PCS
B		Curved Washer Nut	Ø5/16"	2 PCS
C		Spanner Wrench	12MM	1 PC
D		Bolt	Ø5/16"*1"	6 PCS
E		Lock Washer	Ø5/16"	6 PCS
F		Flat Washer	Ø5/16"*19D	6 PCS
G		Allen Key	100*50*4mm	1 PC

PART LIST		
1	Table Top	1 PC
2	Leg Frame	2 PCS
3	Stretcher	1 PC
4	Table Leaf	1 PC

IMPORTANT NOTES

- . Place all wooden parts on clean and smooth surface such as rug or carpet to prevent the parts from being scratched.
- . Check to be sure that you have all parts and hardware.
- . Remove all wrapping materials, including staples and packing straps before you start to assemble.
- . Do not tighten all screws and bolts until completely assembled.
- . Keep all hardware out of the reach of children

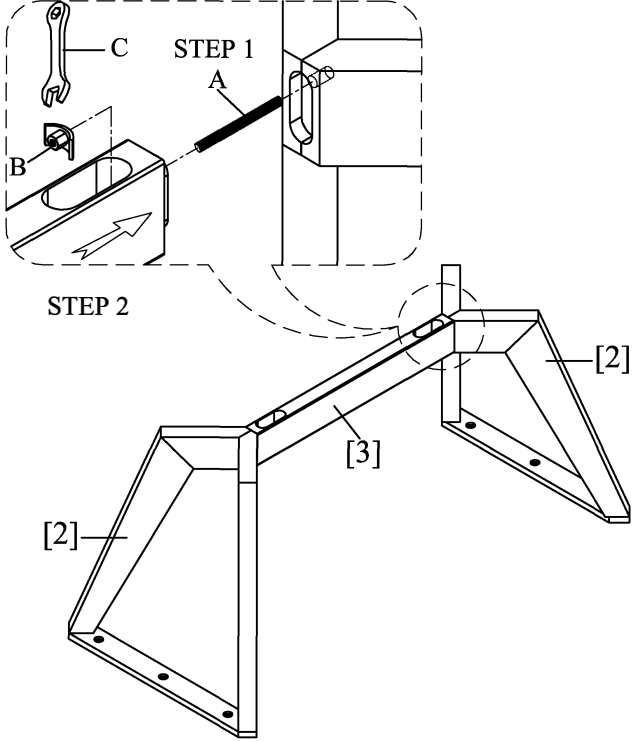

STEP 1. Insert the two threaded bolt (A) into the leg frame (2). Tighten by hand only.

STEP 2. Insert the stretcher (3) into the threaded bolts protruding from the leg frame (2). Attach curve washer nuts (B) onto the threads and secure by hand at first. Tighten evenly using the spanner wrench (C).

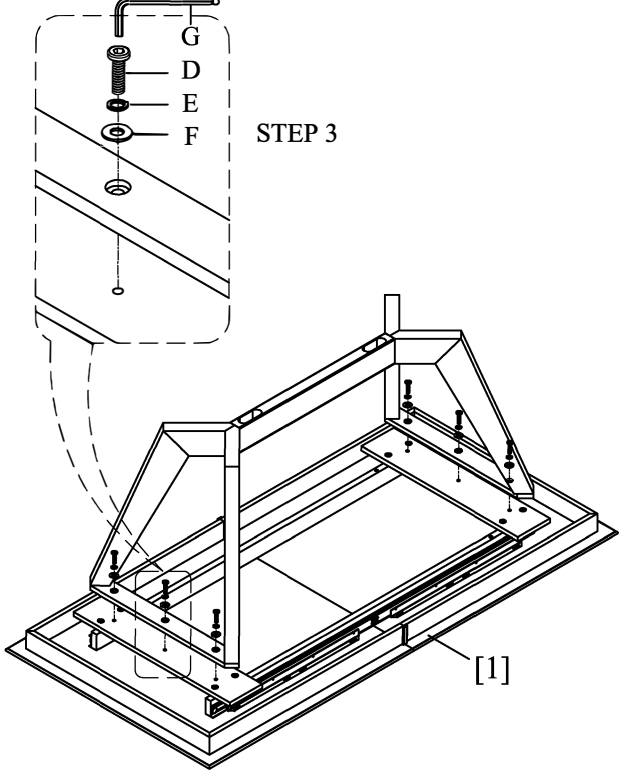

STEP 3. Turn the table top (1) upside down on clean soft surface and attach the leg frame assembly to the table top (1) as shown in the picture using bolt (D), lock washer (E), flat washer (F). And tighten with allen key (G).

ASSEMBLY INSTRUCTION

- 317-746T-L/M 60" Rectangular Table Top
- 317-746B-L/M 60" Trestle Table Base
- 317-747T-L/M 80" Rectangular Table Top
- 317-747B-L/M 80" Trestle Table Base

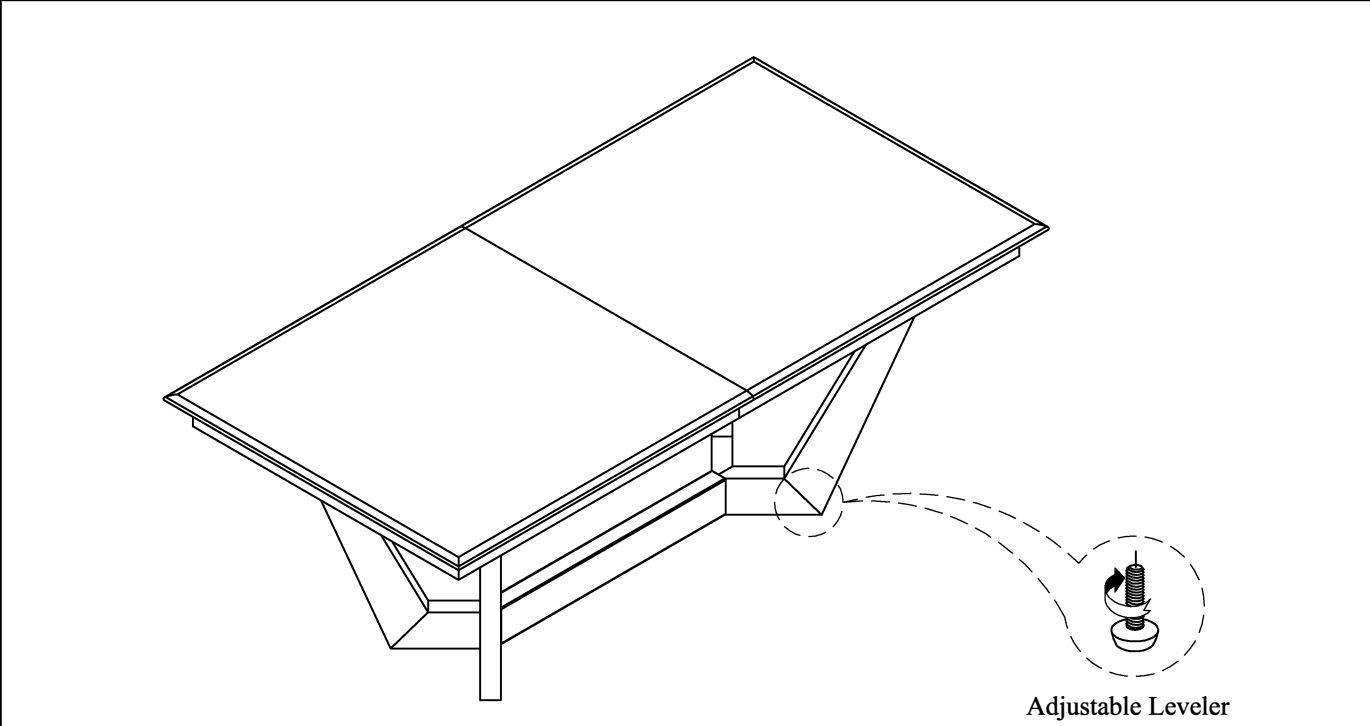

STEP 4. Carefully turn the table up. Adjust leveler if needed to level table on uneven floor.

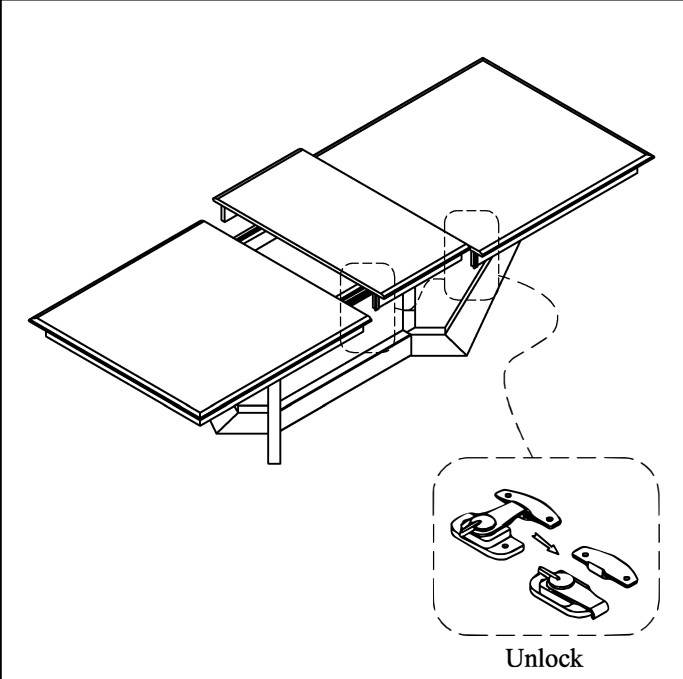

STEP 4. Unlock the table locks and slide open the table halves. Insert one or two the extension table leaf (4) and slide the table halves back together.

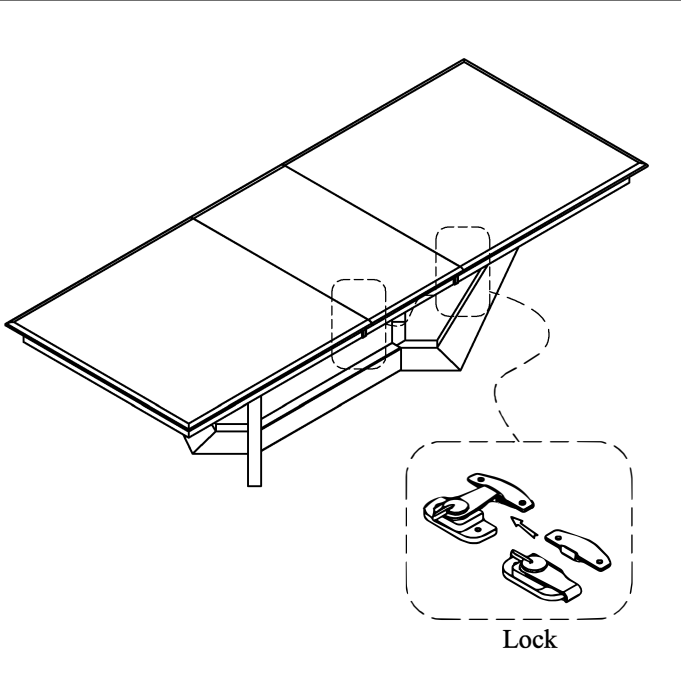

STEP 6. Lock the table locks. Adjust the levelers at the bottom of the feet till the table is even