

# ASSEMBLY INSTRUCTION

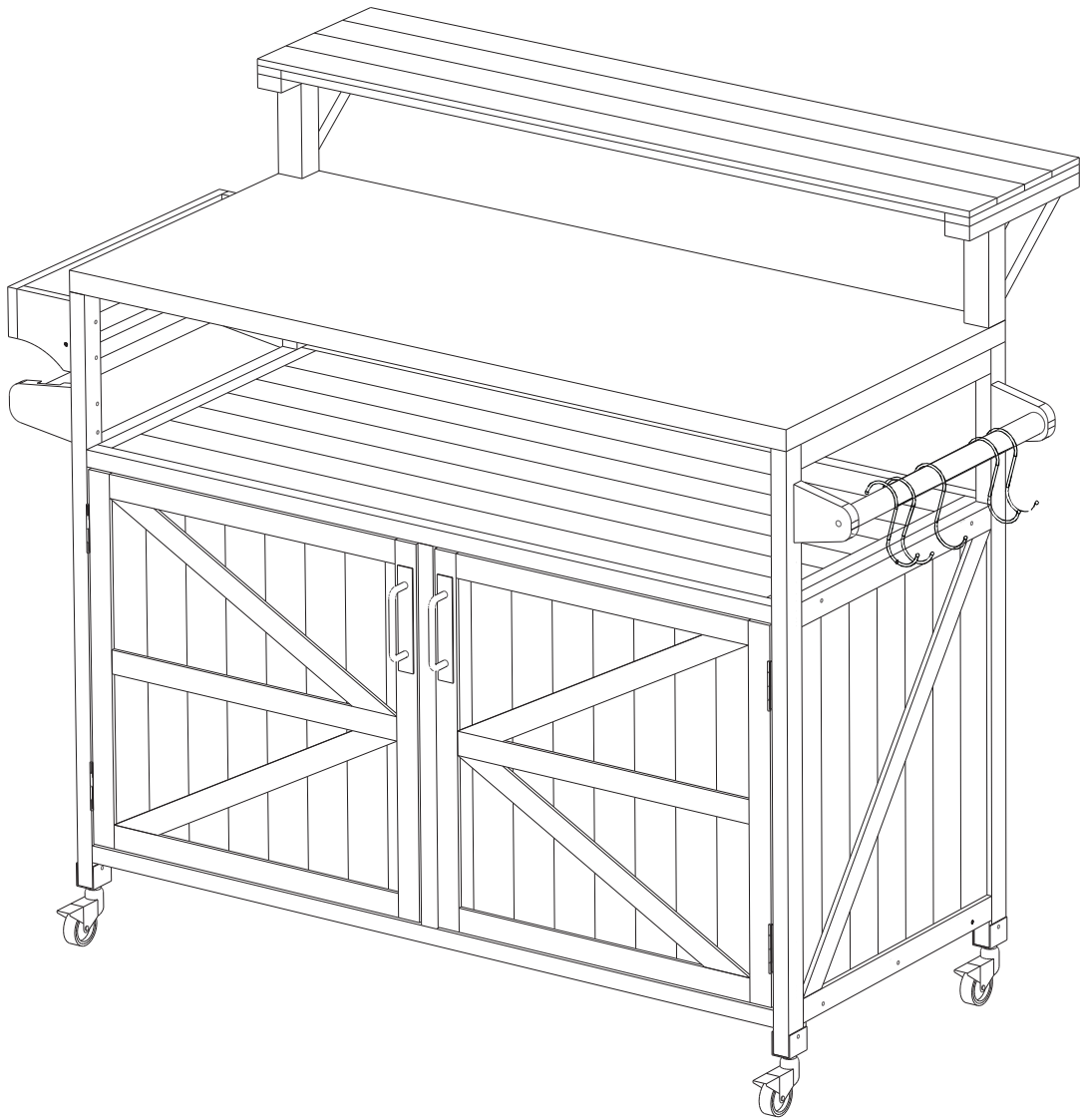

## IMPORTANT NOTE:





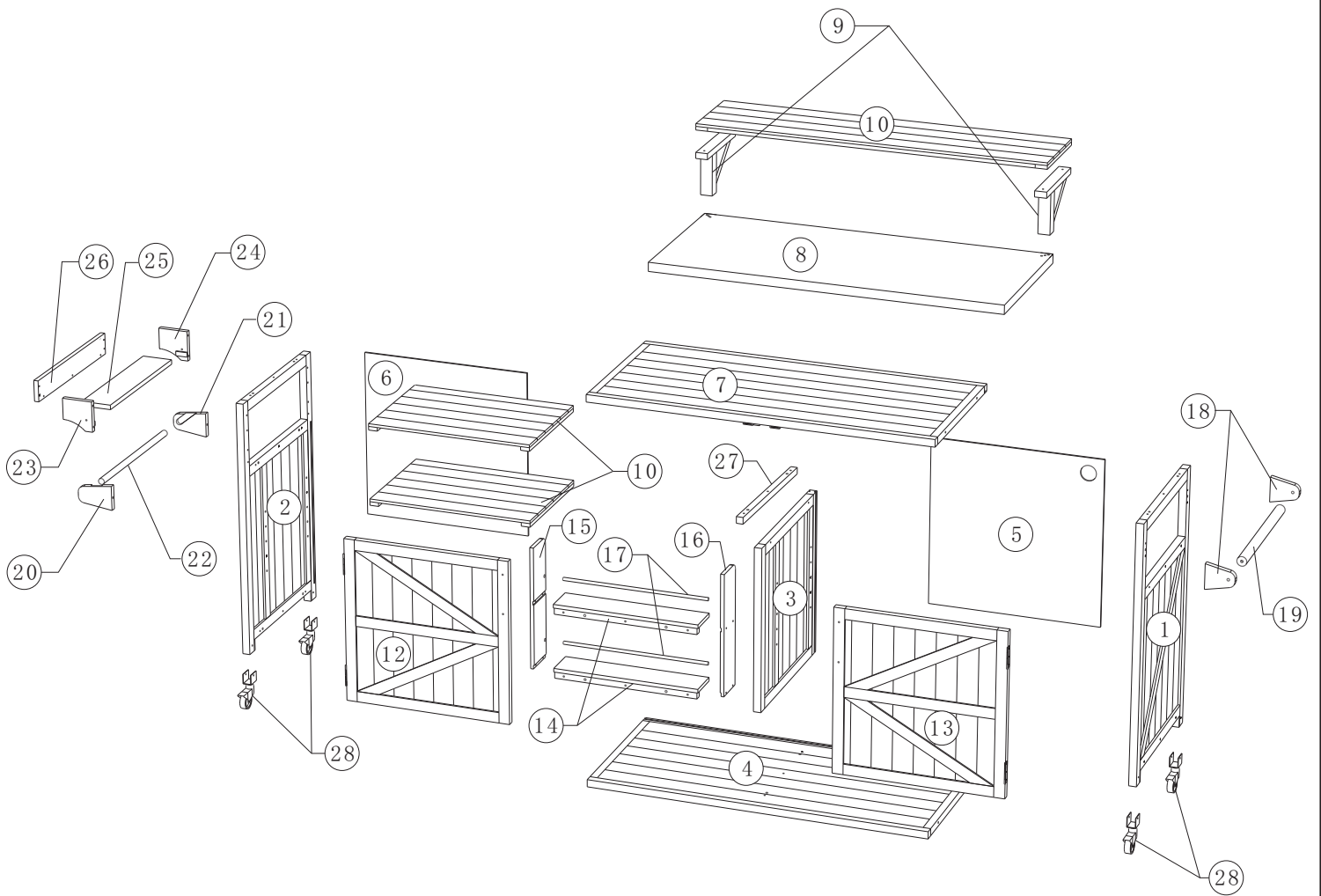

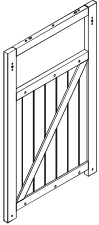
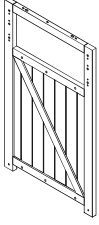
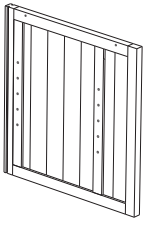
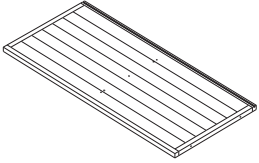
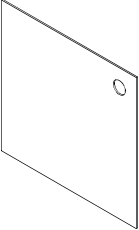
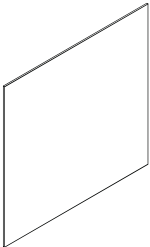
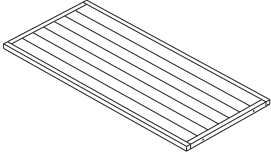
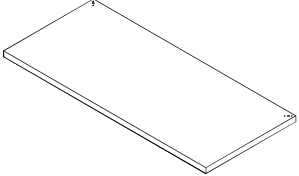
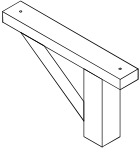
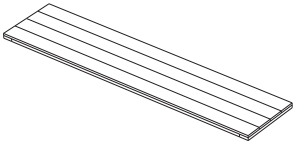
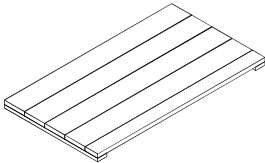
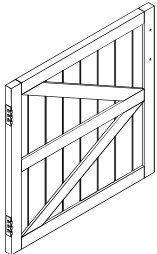
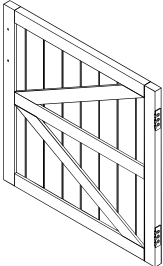
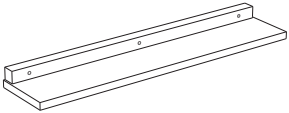
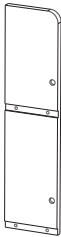
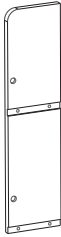
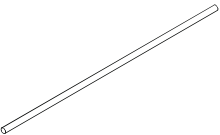
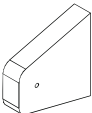
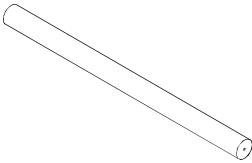
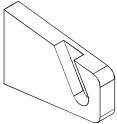
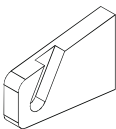
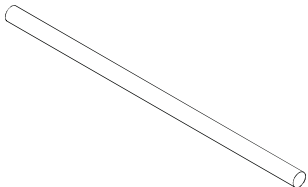
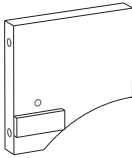
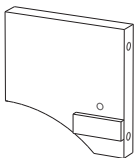
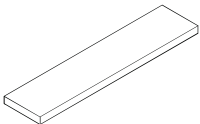
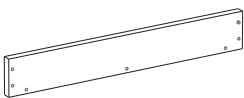
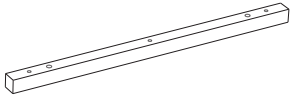
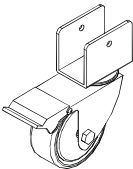

- ① PLACE ALL PARTS ON A CLEAN AND SMOOTH SURFACE SUCH AS A RUG OR CARPET TO AVOID THE PARTS FROM BEING SCRATCHED.
- ② BEFORE YOU BEGIN, KINDLY FOLLOW THE ASSEMBLY INSTRUCTIONS STEP BY STEP.
- ③ DO NOT TIGHTEN ALL SCREWS AND BOLTS UNTIL THIS ITEM IS FULLY SET-UP.

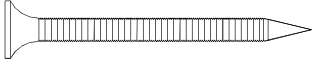
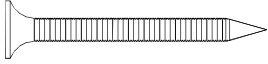
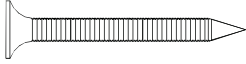
# DETAIL VIEW

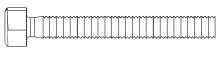
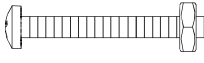
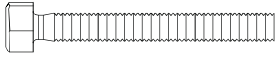

①		1PC	②		1PC	③		1PC	④		1PC
⑤		1PC	⑥		1PC	⑦		1PC	⑧		1PC
⑨		2PCS	⑩		1PC	⑪		2PCS	⑫		1PC
⑬		1PC	⑭		2PCS	⑮		1PC	⑯		1PC
⑰		2PCS	⑱		2PCS	⑲		1PC	⑳		1PC
㉑		1PC	㉒		1PC	㉓		1PC	㉔		1PC
㉕		1PC	㉖		1PC	㉗		1PC	㉘		4PCS

# HARDWARE LIST

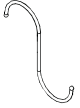
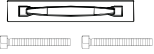
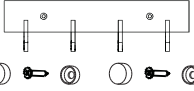
 (A) M3.5*60(4PCS)	 (B) M3.5*50(33PCS)	 (C) M3.5*40(5PCS)
 (D) M3.5*35(4PCS)	 (E) M3.0*30(23PCS)	 (F) M3.0*16(16PCS)
 (G) M6*40(2PCS)	 (H) M4*35(4PCS)	 (I) M6*50(2PCS)
(J)  28PCS	(K)  2PCS	(L)  8PCS
(M)  1PC	(N)  5PCS	(O)  2PCS
(P)  1PCS		

## ASSEMBLY TOOLS REQUIRED(NOT INCLUDED)

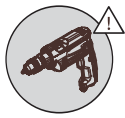

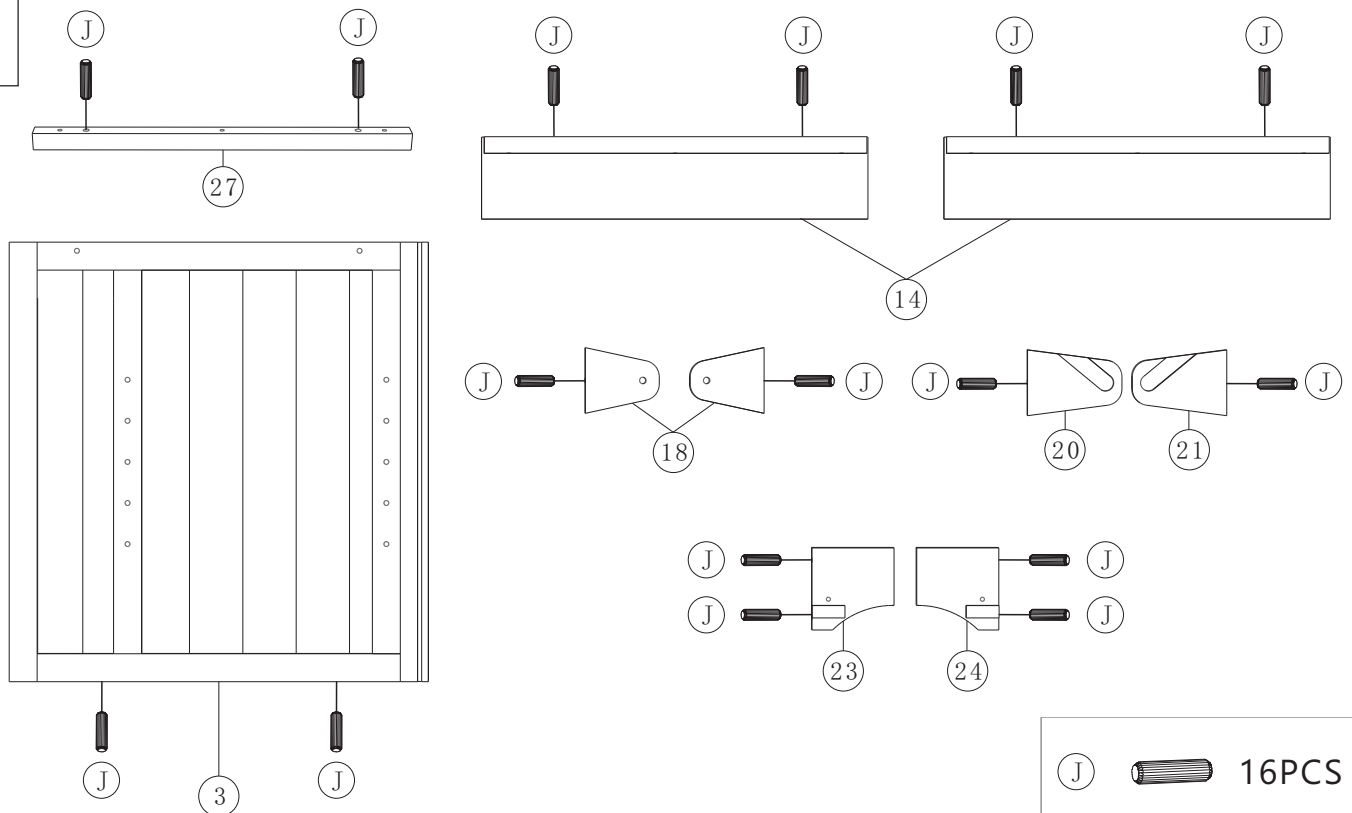

PLEASE BE CAREFUL DO NOT DAMAGE THE HOLE POSITION WHEN YOU USE POWERTOOLS

# 1



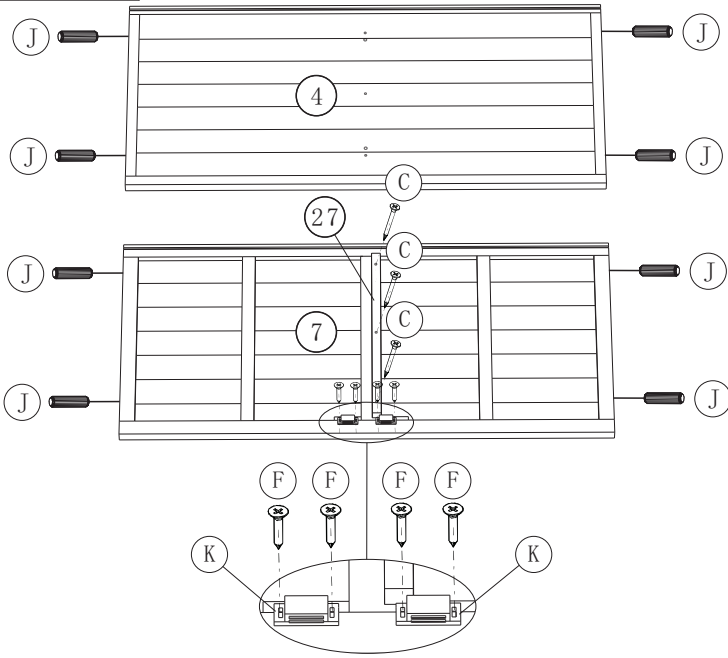

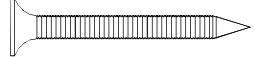
# 2

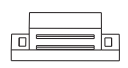

 C M3.5*40(3PCS)	 F M3.0*16(4PCS)
 J 8PCS	 K 2PCS

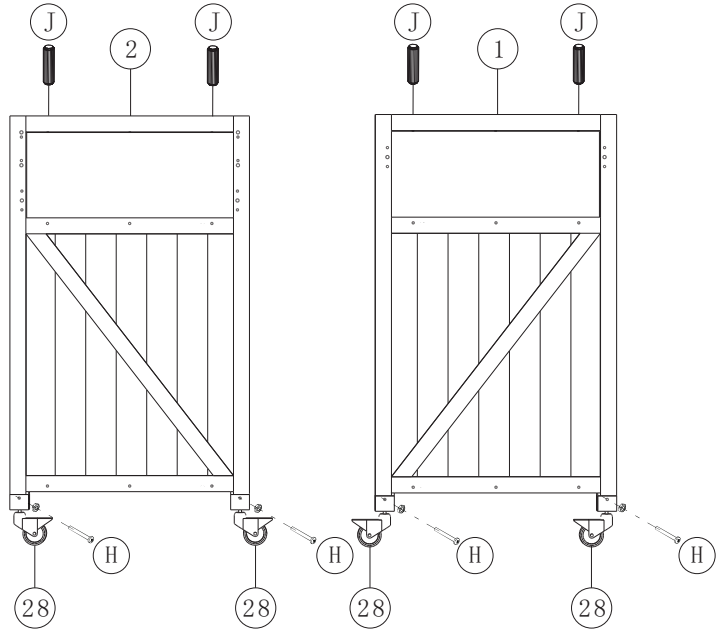

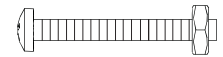
# 3

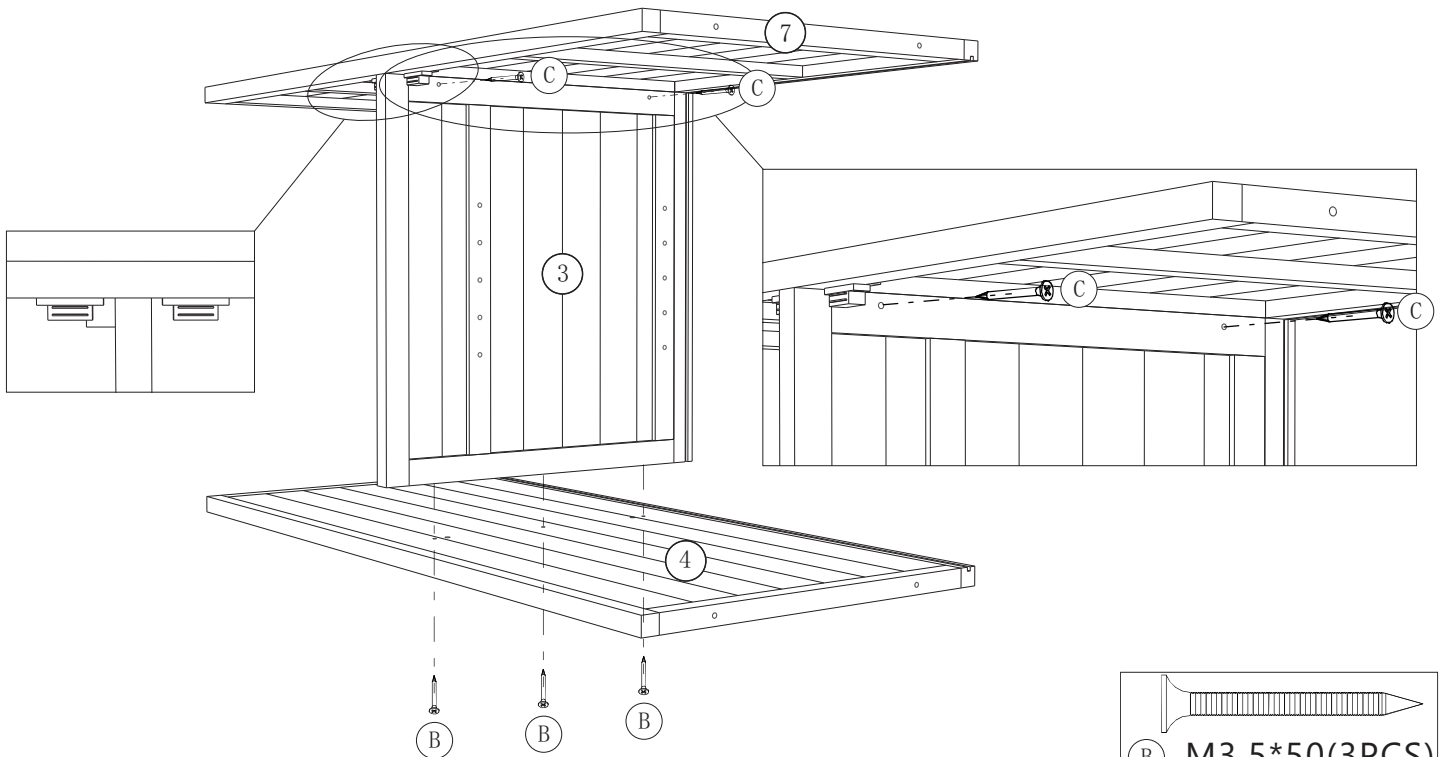

 H M4*35(4PCS)
 J 4PCS

# 4

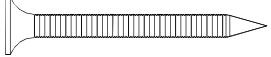

 B M3.5*50(3PCS)
 C M3.5*40(2PCS)

5

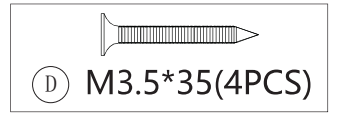
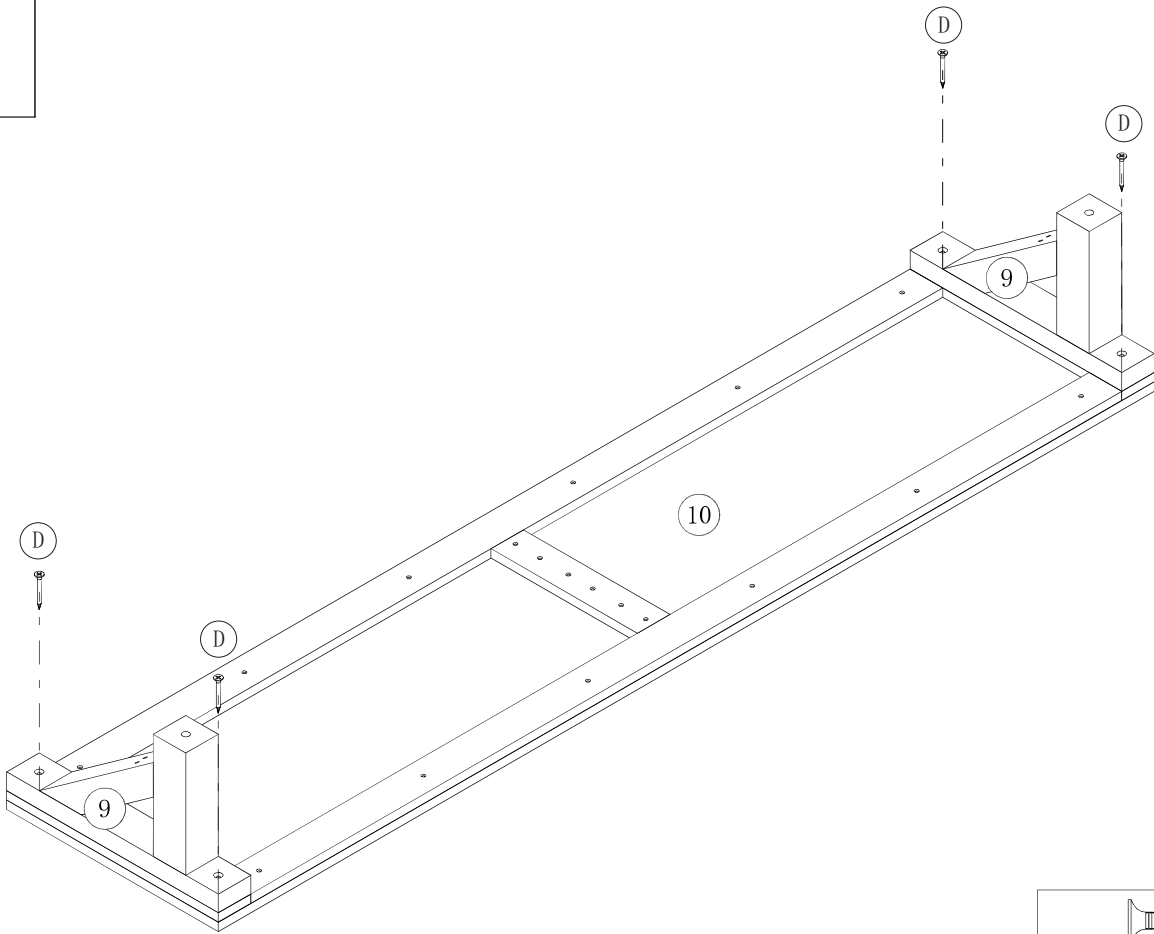

6

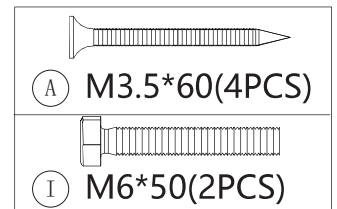
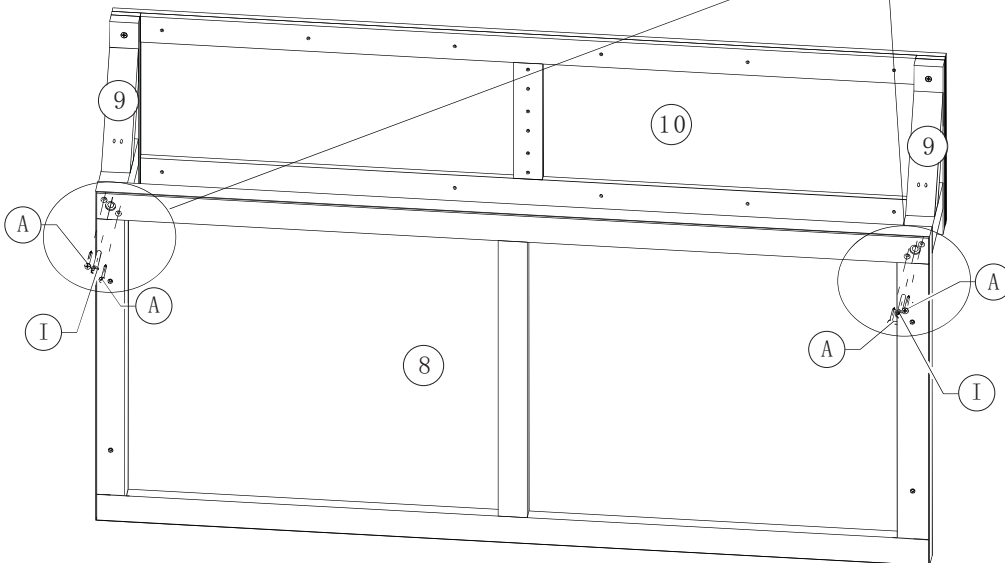
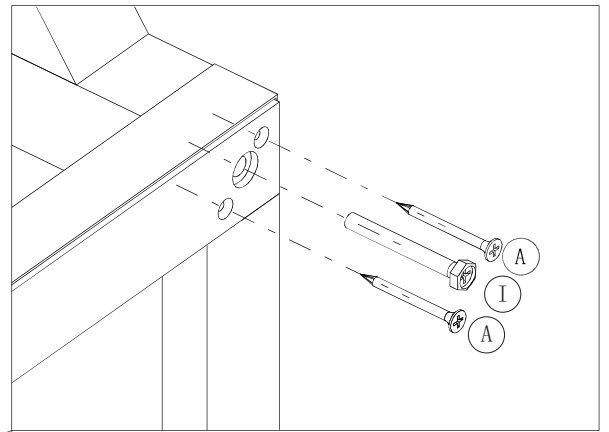

# 7

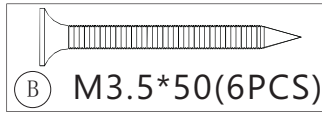
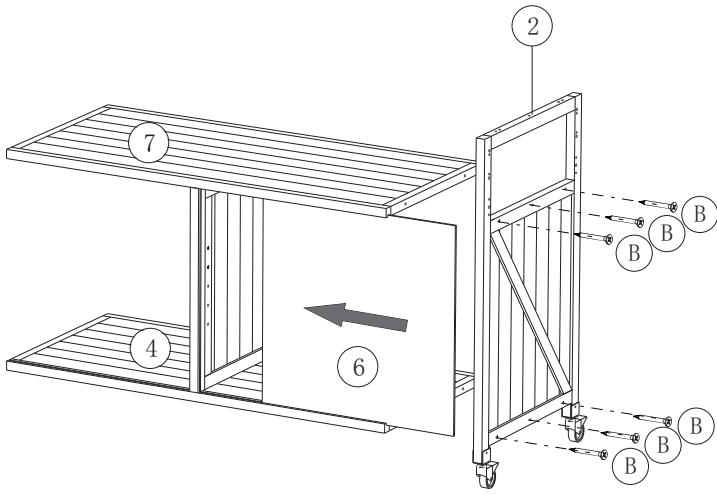

# 8

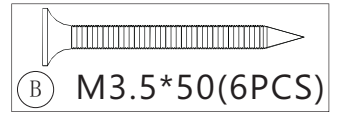
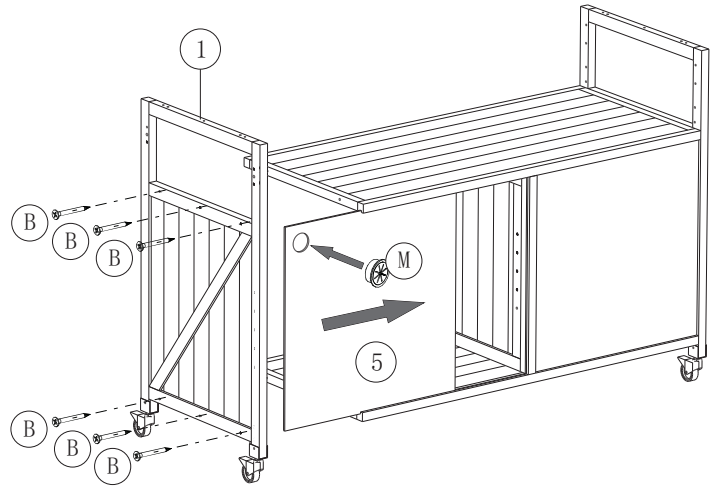

# 9

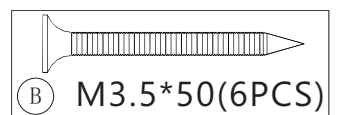
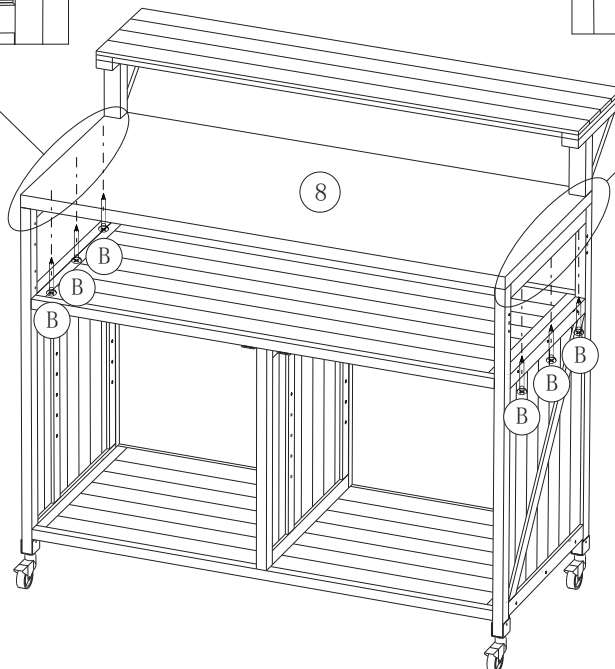
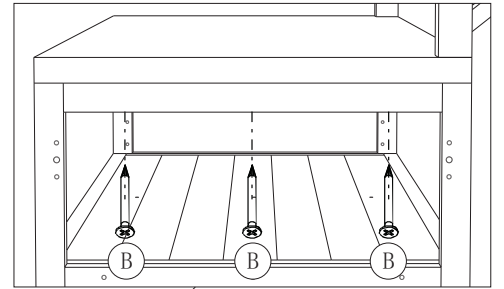
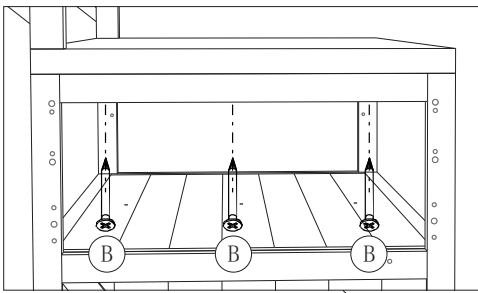

# 10

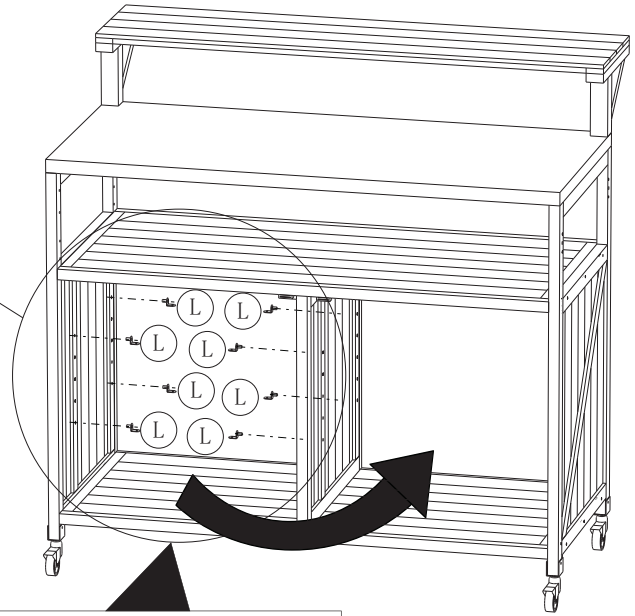
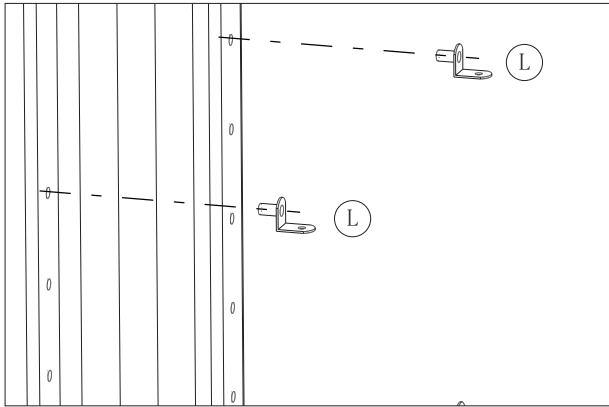

Part (L) can be placed on the left or right side as desired. The height can be freely adjusted.

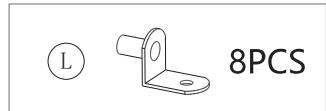

# 11

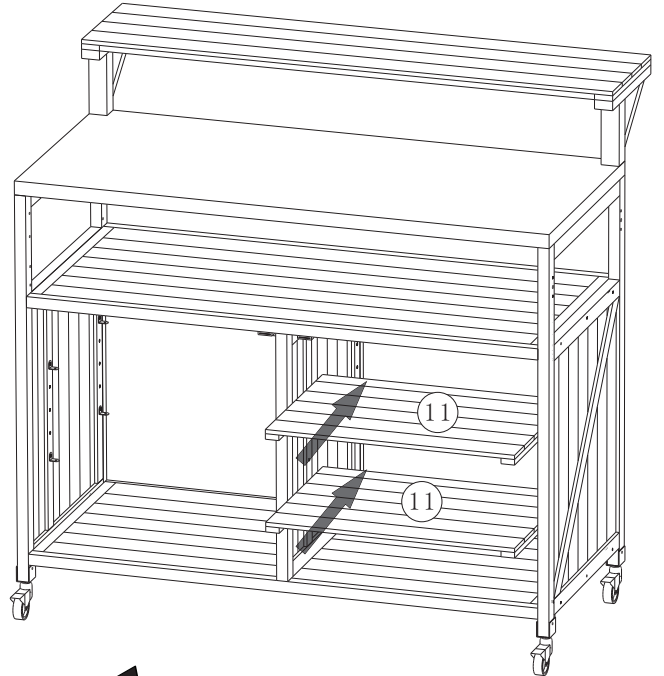
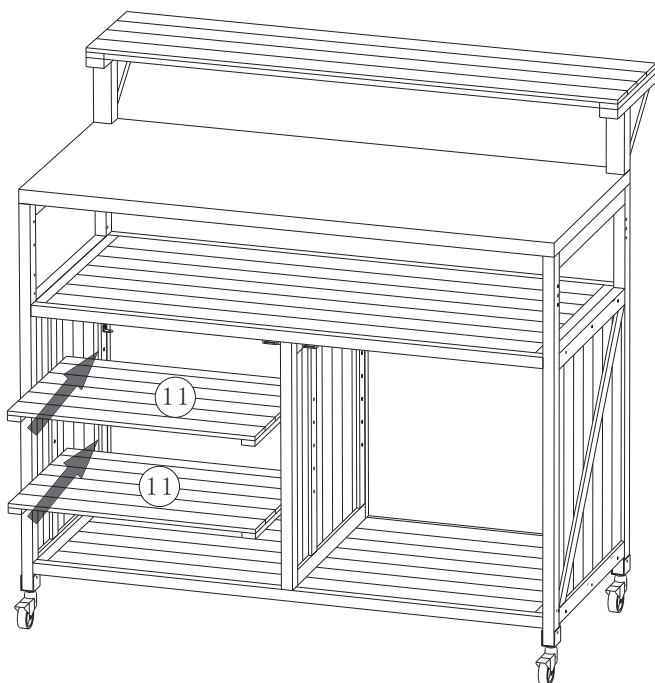

The two shelves (11) can be put into any left or right side as desired. The height can be freely adjusted.

# 12

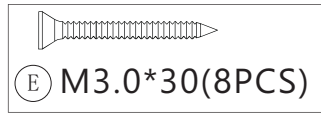
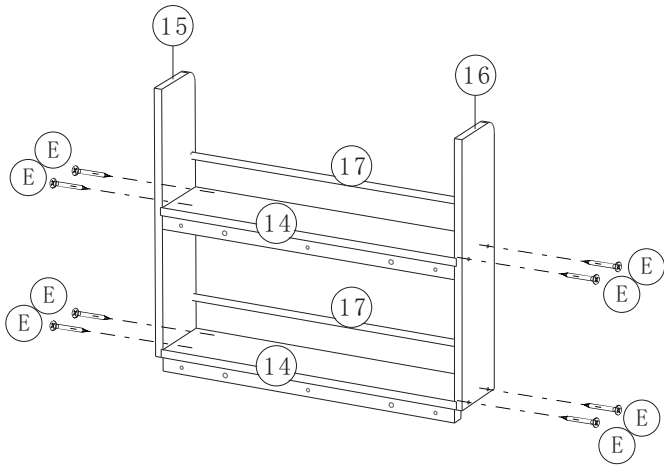

# 13

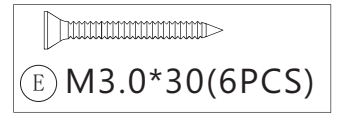
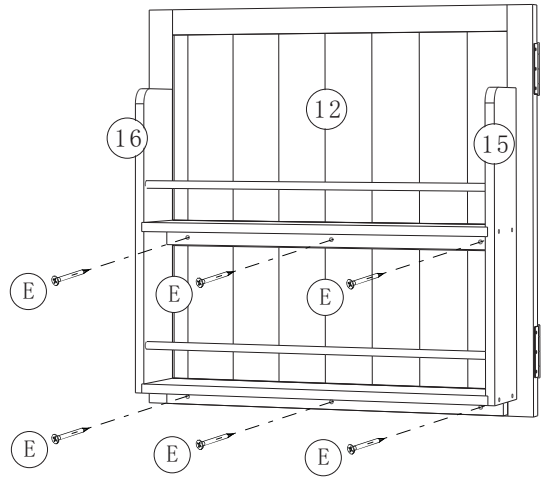

# 14

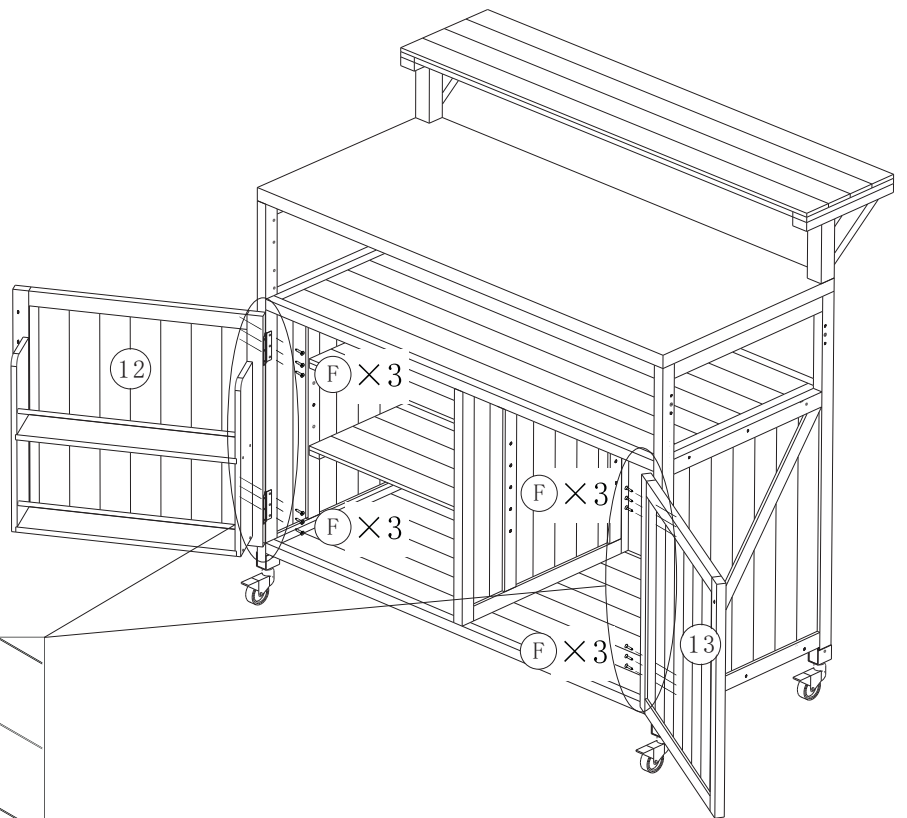

3.00 mm

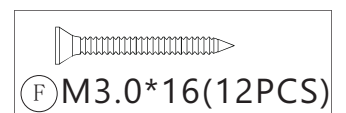
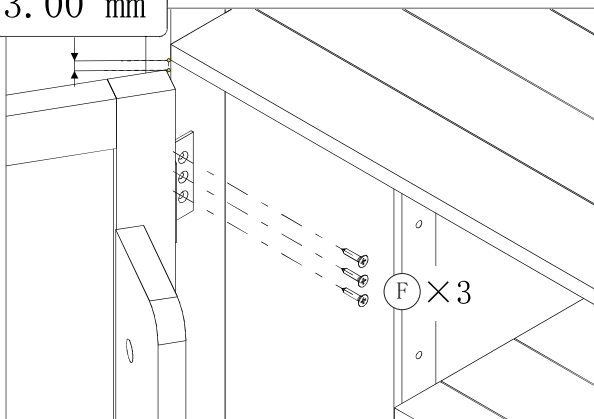

# 15

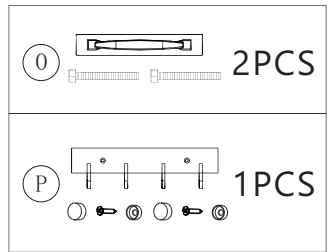
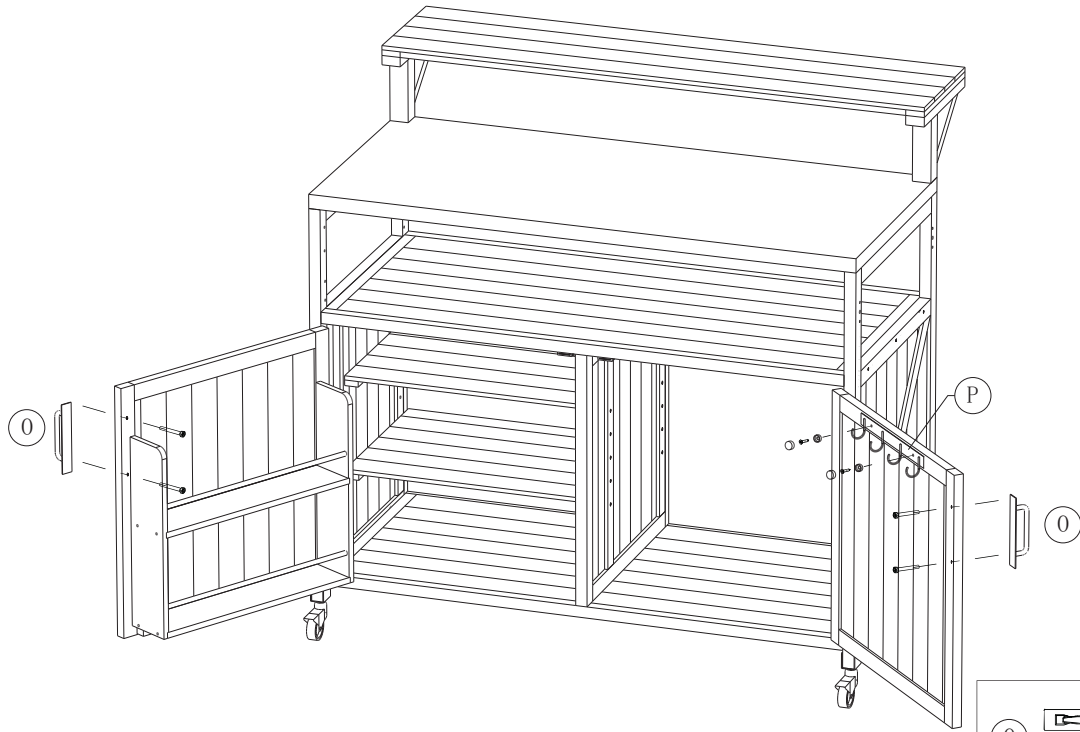

# 16

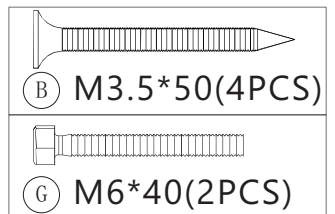
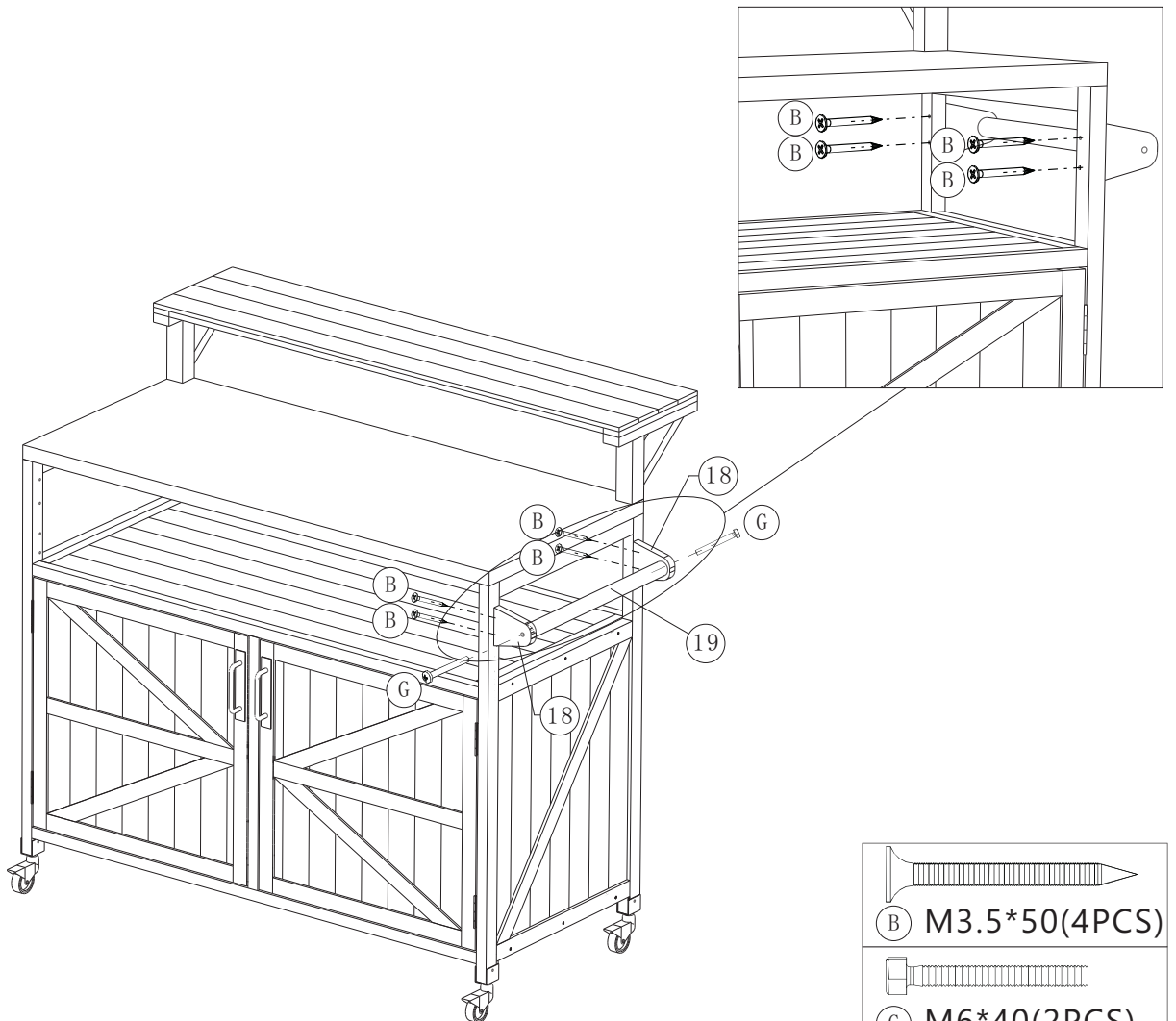

# 17

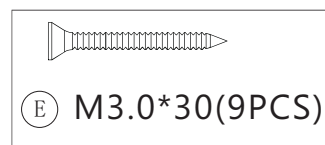
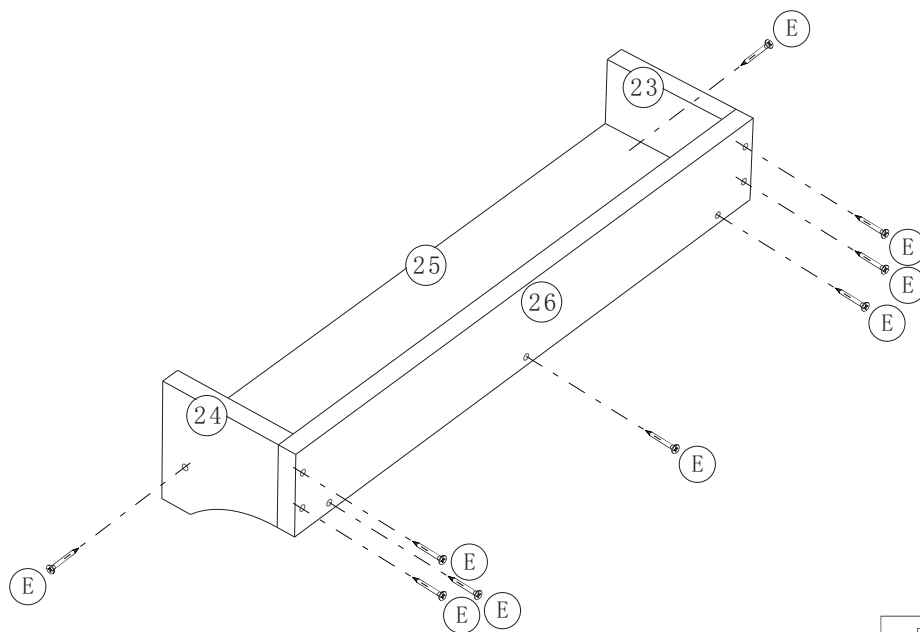

# 18

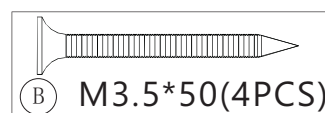
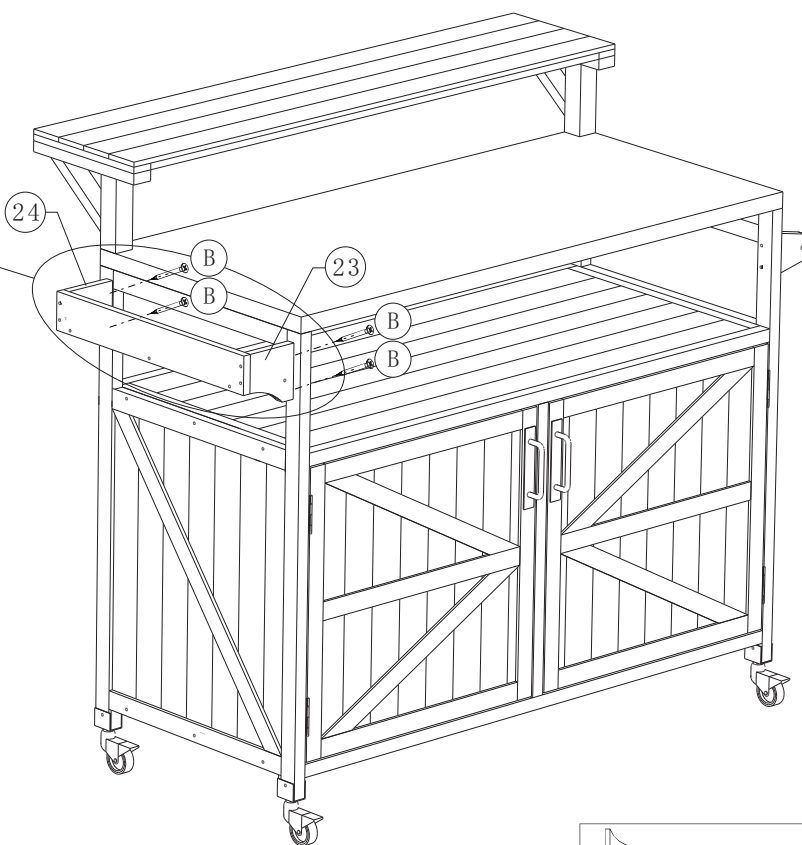
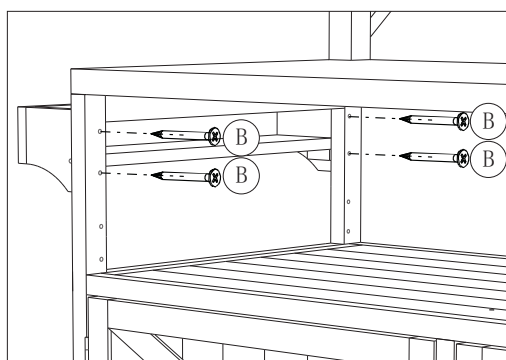

# 19

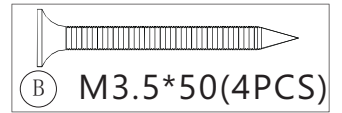
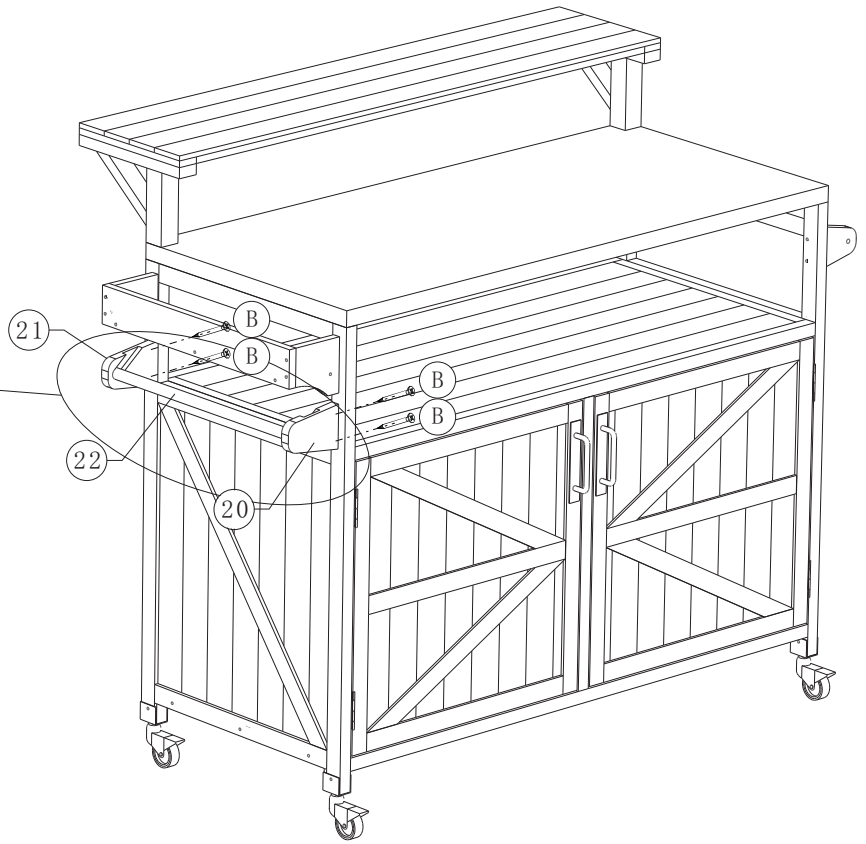
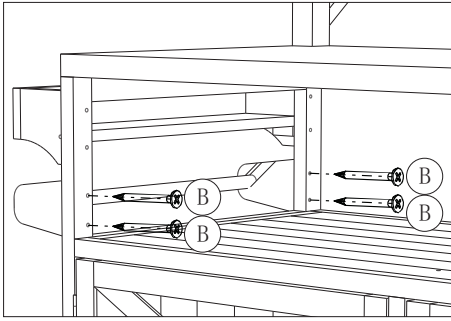

# 20

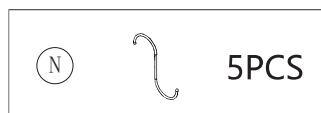

# 21

