

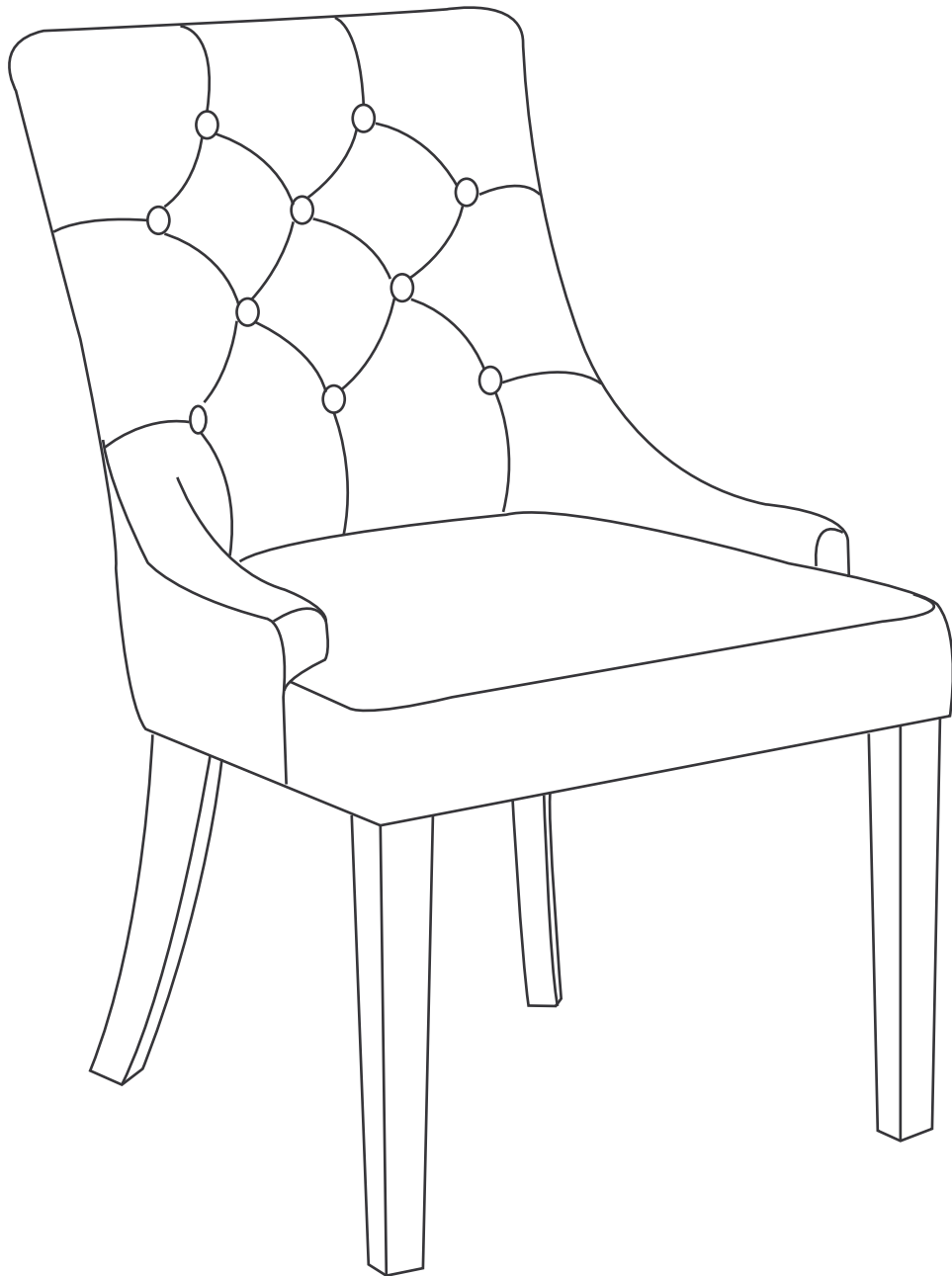

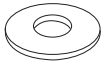



DINING CHAIR

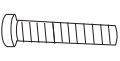
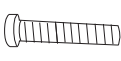

Hardware:

A×8  Φ8 Flat washer	B×8  Φ8 Lock washer	C×1  M8 Allen key	D×4  M8×55MM Shorter Screw	E×4  M8×60MM Longer Screw
---	--	--	---	--

Parts list:

F×1  Back
G×2  Hind Legs
H×2  Front Legs

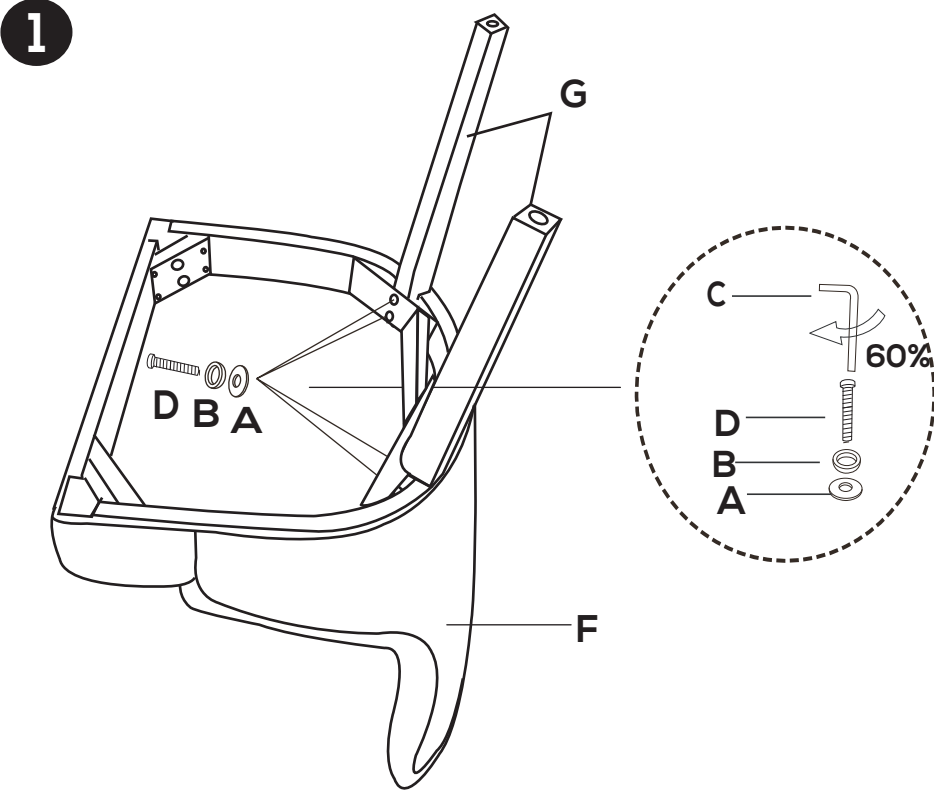

Put chair back on a clean flat surface. Align Hind legs in the seat pad as shown in the diagram.

Using SHORTER SCREW (D) with Washer (#A,B).

DO NOT FULLY TIGHTEN.

First HAND tighten then tightened using key up-to 60-80% only at this stage.

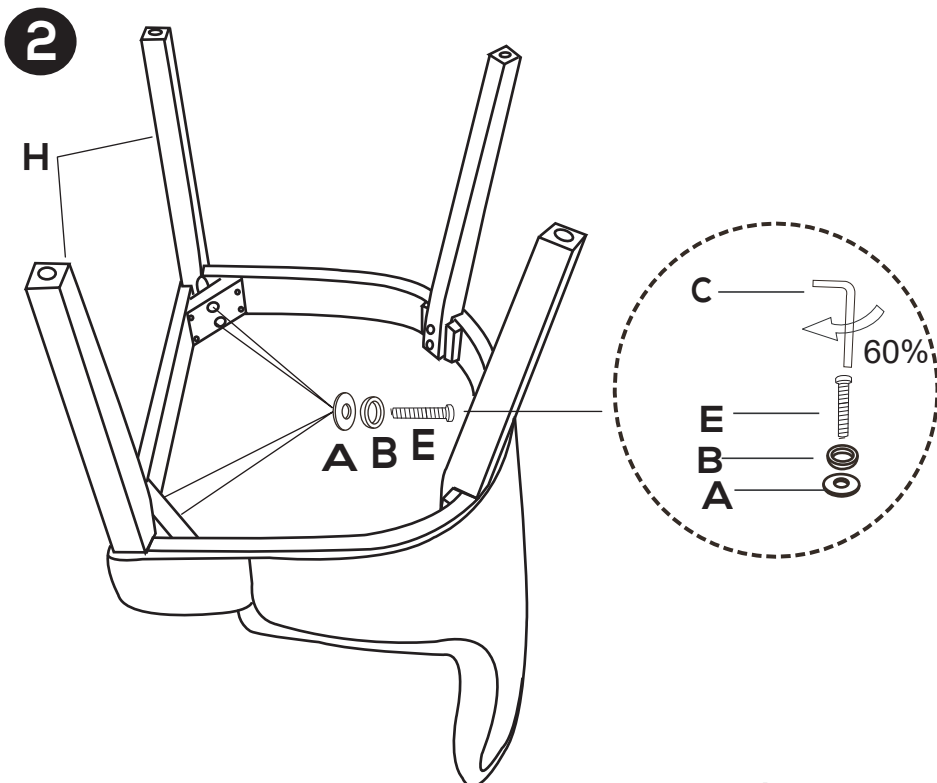

Align front legs in the seat pad as shown in the diagram.

Using LONGER SCREW (E) with Washer (#A,B).

DO NOT FULLY TIGHTEN.

First HAND tighten then tightened using key up-to 60-80% only at this stage.

3

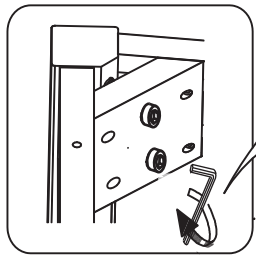
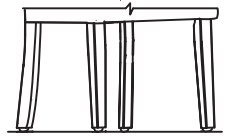
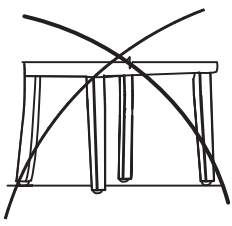

100%

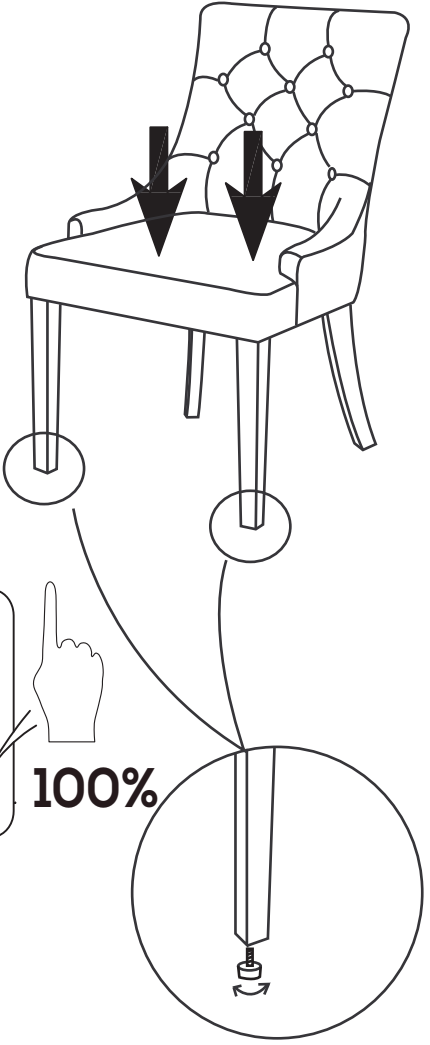

Put chair in the upright position and SIT ON THE CHAIR to press downwards on the seat pad ensuring that all 4 feet touch the ground and chair is leveled.

Proceed to tighten all screws making sure the chair remains level when tightening.

Check that all screws are tight on a regular basis to ensure chair remains level and secure.

Also you can using adjustable feet to keep four legs level .

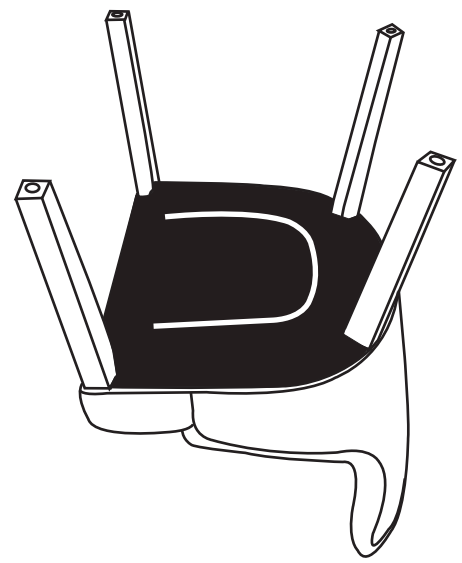

4

