

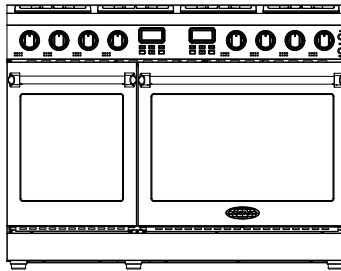

RANGE

COS-GRC304KB(-BK) COS-GRC366KB(-BK)
COS-GRC488KB(-BK)

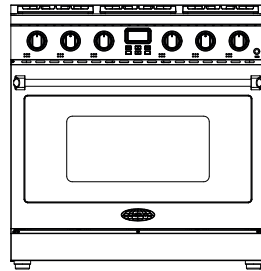
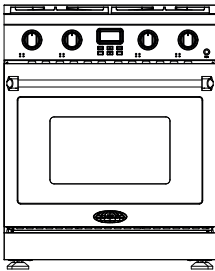

SLIDE-IN GAS RANGE

INSTALLATION INSTRUCTIONS

IMPORTANT: READ AND SAVE THESE INSTRUCTIONS.
FOR RESIDENTIAL USE ONLY.

INSTALLER: PLEASE LEAVE THESE INSTRUCTIONS WITH THIS UNIT FOR
THE OWNER.

OWNER: PLEASE RETAIN THESE INSTRUCTIONS FOR FUTURE
REFERENCE.

THANK YOU FOR YOUR PURCHASE

Thank you for your purchase. We know that you have many brands and products to choose from and we are honored to know that you have decided to take one of our products into your home and hope that you enjoy it.

COSMO Appliances are designed according to the strictest safety and performance standard for the North American market. We follow the most advanced manufacturing philosophy. Each appliance leaves the factory after thorough quality inspection and testing. Our distributors and our service partners are ready to answer any questions you may have regarding how to install, use and care for your products. We hope that this manual will help you learn to use the product in the safest and most effective manner.

Before using this product, please read through this manual carefully. Keep this user manual in a safe place for future reference. Please ensure that other persons using this product are familiar with these instructions as well.

If you have any questions or concerns, please contact the dealer from whom you purchased the product, or contact our Customer Support at:

1-888-784-3108

Reach us online at:

www.cosmoappliances.com



TABLE OF CONTENTS

RANGE SAFETY	4
Anti-tip Device	7
INSTALLATION REQUIREMENTS	8
Tools and Parts	8
Location Requirements	12
Product Specifications.....	14
Product Dimensions	15
Clearances.....	18
Venting Requirements.....	20
Electrical Requirements	21
Gas Supply Requirements	23
INSTALLATION INSTRUCTIONS	27
Unpack Range	27
Install Rear Rubber Pads (Optional)	28
Install Anti-tip Device	29
Install/Remove Control Knobs.....	35
Install/Remove Oven Door Handle.....	36
Removing/Assembling Oven Door	39
Gas Connection.....	41
Complete Installation.....	45
Electrical Connection.....	45
Placement and Leveling Range.....	46
Verify Anti-tip Bracket Engagement	48
Assembling the Surface Burners and Grates	49
Checking Operation of the Surface Burners	52
Checking Operation of the Oven.....	55
GAS CONVERSION	57

RANGE SAFETY

READ ALL INSTRUCTIONS BEFORE USING THE APPLIANCE

Your safety and the safety of others are very important.

We have provided many important safety messages in this manual and on your appliance. Always read and obey all safety messages.



This is the safety alert symbol.

This symbol alerts you to potential hazards that can kill or hurt you and others.

All safety messages will follow the safety alert symbol and either the word "WARNING" or "CAUTION." These words mean:



You can be killed or seriously injured if you don't follow instructions.



A potentially hazardous situation which, if not avoided, could result in minor or moderate injury.

All safety messages will tell you what the potential hazard is, tell you how to reduce the chance of injury, and tell you what can happen if the instructions are not followed.

In the State of Massachusetts, the following installation instructions apply:

- Installations and repairs must be performed by a qualified or licensed contractor, plumber, or gasfitter qualified or licensed by the State of Massachusetts.
- If using a ball valve, it shall be a T-handle type.
- A flexible gas connector, when used, must not exceed 3 feet (91.5 cm).

California Proposition 65 Warning

 **WARNING:** Cancer and Reproductive Harm - www.P65Warnings.ca.gov.

WARNING



FIRE AND EXPLOSION HAZARD

If the information in this manual is not followed exactly, a fire or explosion may result causing property damage, personal injury or death.

- Do not store or use gasoline or other flammable vapors and liquids in the vicinity of this or any other appliance.
- **WHAT TO DO IF YOU SMELL GAS**
 - Do not try to light any appliance.
 - Do not touch any electrical switch.
 - Do not use any phone in your building.
 - Clear the room, building, or area of all occupants.
 - Immediately call your gas supplier from a neighbor's phone. Follow the gas supplier's instructions.
 - If you cannot reach your gas supplier, call the fire department.
- Installation and service must be performed by a qualified installer, service agency or the gas supplier.

WARNING

Never Operate the Top Surface Cooking Section of this Appliance Unattended.

- Failure to follow this warning statement could result in fire, explosion, or burn hazard that could cause property damage, personal injury, or death.
- If a fire should occur, keep away from the appliance and immediately call your fire department.

DO NOT ATTEMPT TO EXTINGUISH AN OIL/GREASE FIRE WITH WATER.

WARNING

- Gas leaks cannot always be detected by smell. Gas suppliers recommend that you use a gas detector approved by UL or CSA. For more information, contact your gas supplier.
- Do not install a ventilation system that blows air downward toward this cooking appliance. This type of ventilation system may cause ignition and combustion problems with this cooking appliance resulting in personal injury or unintended operation.
- This appliance is intended for normal residential use. It is not approved for commercial use, outdoor installation, or any other application not specifically allowed by this manual.
- This appliance requires connection to a 3-prong, 120VAC single-phase (split-phase), 60Hz grounded electrical source protected by a 15- or 20-Amp circuit breaker or slow blow fuse. When installed, appliance must be electrically grounded in accordance with local codes or, in the absence of local codes, with the National Electrical Code, NFPA 70 or the Canadian Electric Code, CSA C22.1-02.
- Proper installation is the responsibility of the installer. Any adjustment and service should be performed only by qualified range installers or service technicians. The manufacturer is not responsible for any injury or damage that may result from incorrect or defective installation by unauthorized personnel.
- Product failure due to improper installation is not covered under warranty.

ANTI-TIP DEVICE

WARNING



TIP OVER HAZARD

- A child or adult can tip the range and be killed.
- Install anti-tip bracket to floor or wall per installation instructions.
- Slide range back so rear range foot is engaged in the slot of the floor-mounting anti-tip bracket or rear range pin is engaged under the wall-mounting anti-tip bracket.
- Re-engage the anti-tip bracket if range is moved.
- Do not operate the range without anti-tip bracket installed and engaged.
- Failure to follow these instructions can result in death or serious burns to children and adults.

Making sure the anti-tip bracket is installed:

- Slide range forward.
- Look for the anti-tip bracket securely attached to floor or wall.
- Slide range back and make sure rear range foot is under floor-mounting anti-tip bracket or rear range pin is under the wall-mounting anti-tip bracket.

Range foot

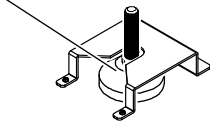

Floor-mounting anti-tip bracket

Range pin

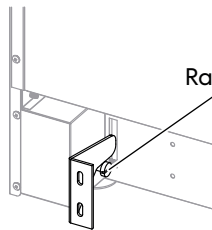

Wall-mounting anti-tip bracket

INSTALLATION REQUIREMENTS

TOOLS AND PARTS

Gather the required tools and parts before starting installation. Read and follow the instructions provided with any tools listed here.

TOOLS NEEDED

- Tape measure
- Phillips screwdriver
- Level
- Drill and drill bit (for anti-tip bracket installation)
- Adjustable wrench or pliers
- Marker or pencil
- Safety glasses
- Gloves

For Propane/Natural Gas Conversions

- Combination wrench
- Nut driver

PARTS NEEDED

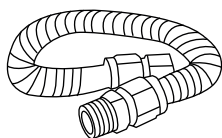

New flexible gas supply line
(3/4" or 1/2" NPT x 1/2" ID)



New Flare Union Adapter
(3/4" or 1/2" NPT x 1/2" ID)

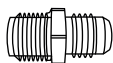

New Flare Union Adapter
(1/2" NPT x 1/2" ID)

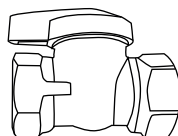

Gas line shut-off valve

PARTS SUPPLIED

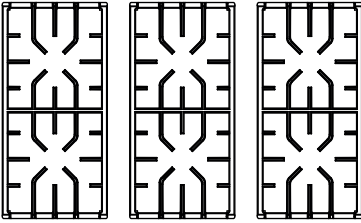

Surface burner grates

30" Models (2)

36" Models (3)

48" Models (4)



Surface burners and caps

(pre-installed)

30" Models (4)

36" Models (6)

48" Models (8)

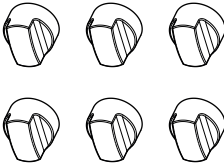

Control knobs

30" Models (4)

36" Models (6)

48" Models (8)

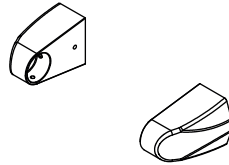

Oven door handle end caps

30" Models (2)

36" Models (2)

48" Models (4)

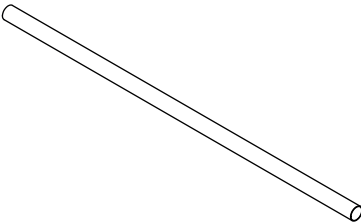

Oven door handle

30" Models (1)

36" Models (1)

48" Models (2)

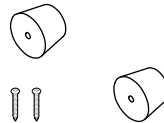

Oven racks

30" Models (2)

36" Models (2)

48" Models (4)

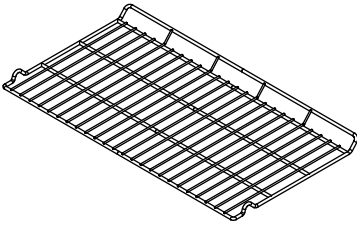

2-Piece broiler pan

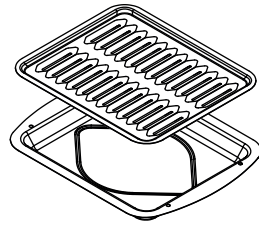

Rear rubber pads (2)

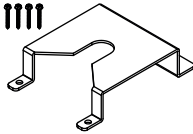

Floor-mounting anti-tip bracket
and mounting screws
30" Models (1)

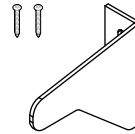

Wall-mounting anti-tip bracket
and mounting screws
36" Models (1)
48" Models (1)

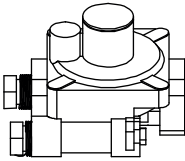

Gas pressure regulator
(pre-installed)

OPTIONAL PARTS

To purchase these or any other accessories or replacement parts, please visit www.cosmoappliances.com or reference the contact information at the end of this manual.

- Stylish color handle & knob kits (sold separately)



Scan to find
available handle &
knob kits

- LP conversion kits (sold separately)



Scan to find
available LP Kits

LOCATION REQUIREMENTS

IMPORTANT: Observe all governing codes and ordinances. Do not obstruct flow of combustion and ventilation air.

- It is the installer's responsibility to comply with installation clearances specified on the model/serial/rating plate. The model/serial/rating plate is located behind the oven door on the oven frame, and also on the back panel of the range.

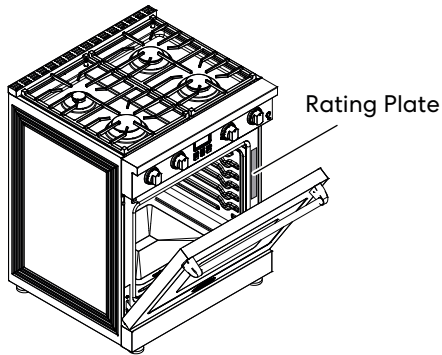

- The range should be located for convenient use in the kitchen.
- Recessed installations must provide complete enclosure of the sides and rear of the range.
- To eliminate the risk of burns or fire by reaching over heated surface units, cabinet storage space located above the surface units should be avoided. If cabinet storage is to be provided, the risk can be reduced by installing a range hood or microwave hood combination that projects horizontally a minimum of 5" (12.7 cm) beyond the bottom of the cabinets.
- Do not install a ventilation system that blows air downward toward the range.
- Do not locate the range where it may be subject to strong drafts.
- All openings in the wall or floor where range is to be installed must be sealed.
- Do not seal the range to the side cabinets.
- Cabinet opening dimensions that are shown must be used.
- The anti-tip bracket must be installed.
- Grounded electrical supply is required. See "Electrical Requirements" section.

- Proper gas supply connection must be available. See "Gas Supply Requirements" section.
- Contact a qualified floor covering installer to check that the floor covering can withstand at least 167°F (75°C).
- Use an insulated pad or 1/4" (0.64 cm) plywood under range if installing range over carpeting.

IMPORTANT: To avoid damage to your cabinets, check with your builder or cabinet supplier to make sure that the materials used will not discolor, delaminate, or sustain other damage.

Mobile Home - Additional Installation Requirements

- The installation of this range must conform to the Manufactured Home Construction and Safety Standard, Title 24 CFR, Part 3280 (formerly the Federal Standard for Mobile Home Construction and Safety, Title 24, HUD Part 280). When such standard is not applicable, use the Standard for Manufactured Home Installations, ANSI A225.1/NFPA 501A or with local codes.

In Canada, the installation of this range must conform with the current standards CAN/CSA-A240-latest edition, or with local codes.

Mobile Home Installations Require:

- When this range is installed in a mobile home, it must be secured to the floor during transit. Any method of securing the range is adequate as long as it conforms to the standards listed above.
- Four-wire power supply cord or cable must be used in a mobile home installation. The appliance wiring will need to be revised. See "Electrical Connection" section.

PRODUCT SPECIFICATIONS

Model	COS-GRC304KB(-BK)
Description	30" Gas Range
Oven Capacity	4.8 cu. ft.
Electrical Requirements	120VAC 60Hz
Exterior Dimensions (WxDxH)	29 7/8" x 29 3/4" x 37 1/4" (75.9 x 75.5 x 94.6 cm)
Height to Cooking Surface	37 1/8" - 38 1/8" (94.3 - 96.9 cm)
Net Weight	185 lb (84.0 kg)

Model	COS-GRC366KB(-BK)
Description	36" Gas Range
Oven Capacity	6.1 cu. ft.
Electrical Requirements	120VAC 60Hz
Exterior Dimensions (WxDxH)	35 7/8" x 29 15/16" x 37 1/4" (91.1 x 76.1 x 94.6 cm)
Height to Cooking Surface	37 1/8" - 40 1/8" (94.3 - 102 cm)
Net Weight	225 lb (102 kg)

Model	COS-GRC488KB(-BK)
Description	48" Gas Range
Oven Capacity	4.8 cu. ft. + 2.2 cu. ft.
Electrical Requirements	120VAC 60Hz
Exterior Dimensions (WxDxH)	47 7/8" x 30 1/6" x 37 3/6" (121.6 x 76.4 x 94.4 cm)
Height to Cooking Surface	37 1/8" - 40 1/8" (94.2 - 102 cm)
Net Weight	311 lb (141 kg)

PRODUCT DIMENSIONS

Your model may appear different from the model depicted. Dimensions given are maximum dimensions.

30" Models: COS-GRC304KB(-BK)

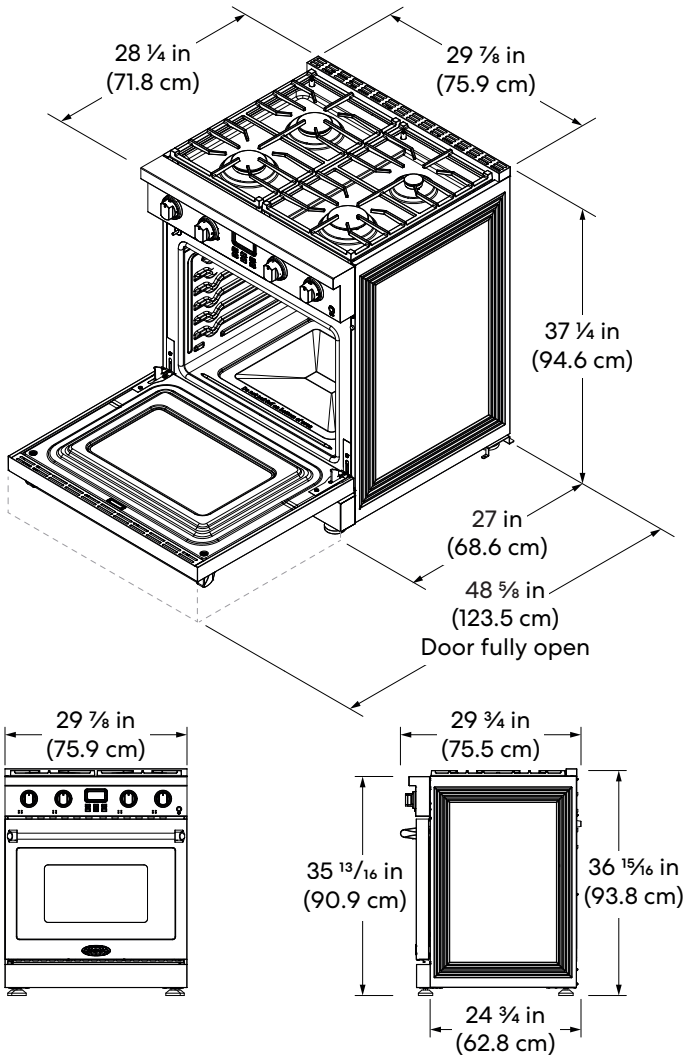

NOTE:

- Range can be raised approximately 1" (2.5 cm) by adjusting the leveling legs.

36" Models: COS-GRC366KB(-BK)

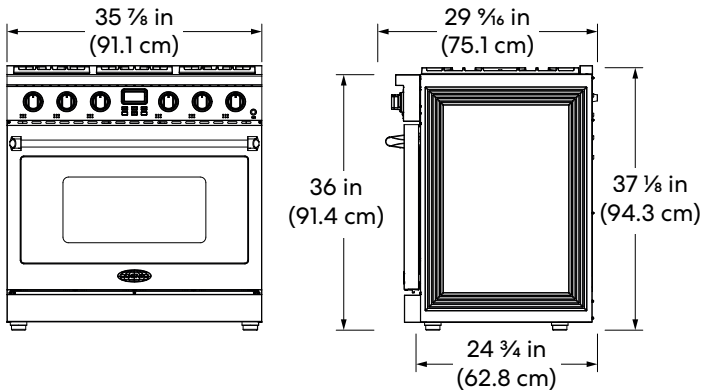
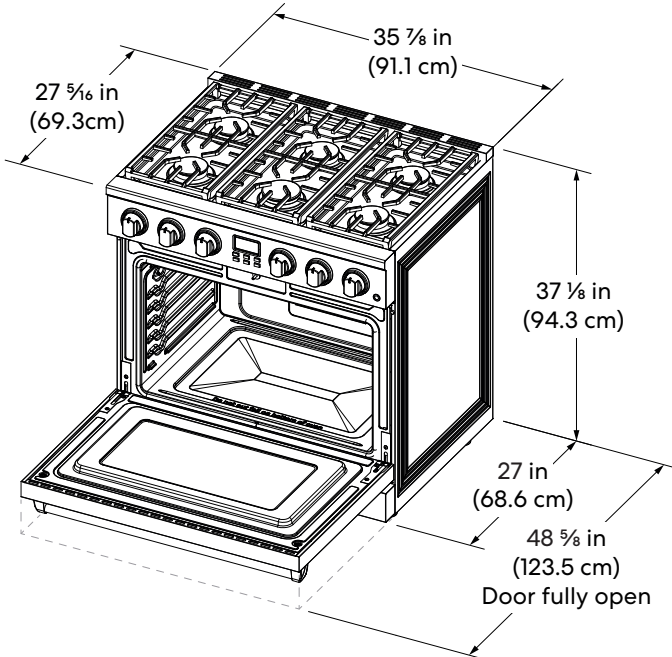

NOTE:

- Range can be raised approximately 3" (7.6 cm) by adjusting the leveling legs.

48" Models: COS-GRC488KB(-BK)

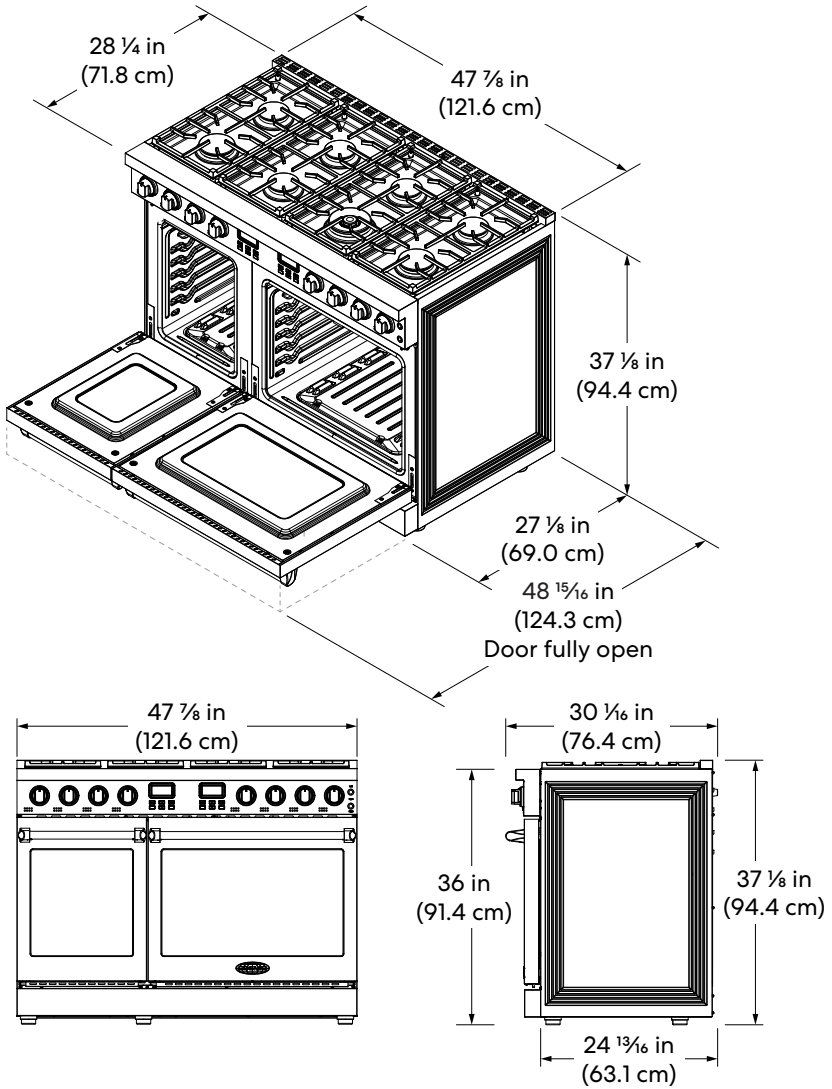

NOTE:

- Range can be raised approximately 3" (7.6 cm) by adjusting the leveling legs.

CLEARANCES

IMPORTANT: Some cabinet and building materials are not designed to withstand the heat produced by the oven for baking and self-cleaning. Check with your builder or cabinet supplier to make sure that the materials used will not discolor, delaminate or sustain other damage.

GIVEN DIMENSIONS ARE MINIMUM CLEARANCES.

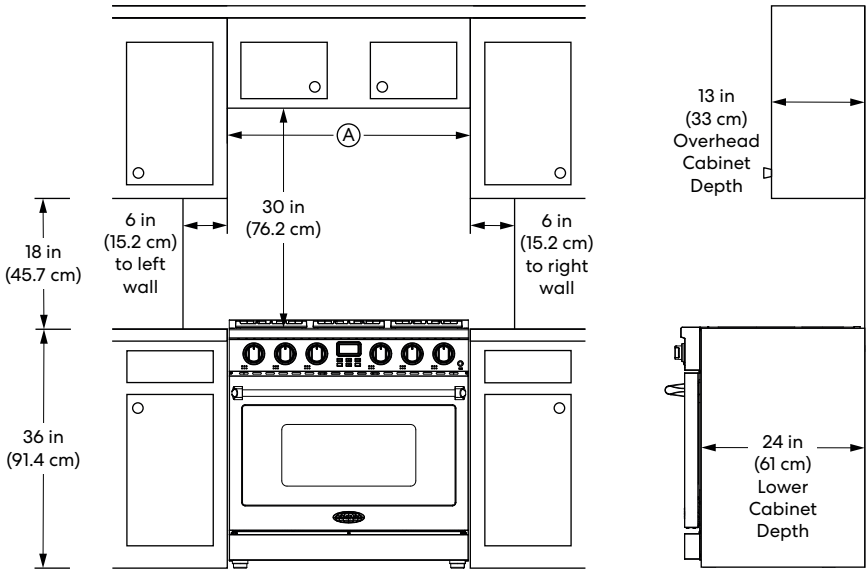

Model	A
	Horizontal Clearance
30" Models: COS-GRC304KB(-BK)	30" (76.2 cm)
36" Models: COS-GRC366KB(-BK)	36" (91.4 cm)
48" Models: COS-GRC488KB(-BK)	48" (121.9 cm)

NOTE:

- 30" (76.2 cm) minimum clearance between cooking surface and bottom of the overhead cabinet.
- 18" (45.7 cm) minimum clearance from upper cabinet to countertop on either side of unit.
- Island Installations: Maintain 6" (15.2 cm) minimum clearance from cutout to back and side edges of countertop.

POWER SUPPLY LOCATION

IMPORTANT: An electrical outlet in the floor, may be either recessed or surface mounted, but an electrical outlet in the wall must be recessed to make the connection.

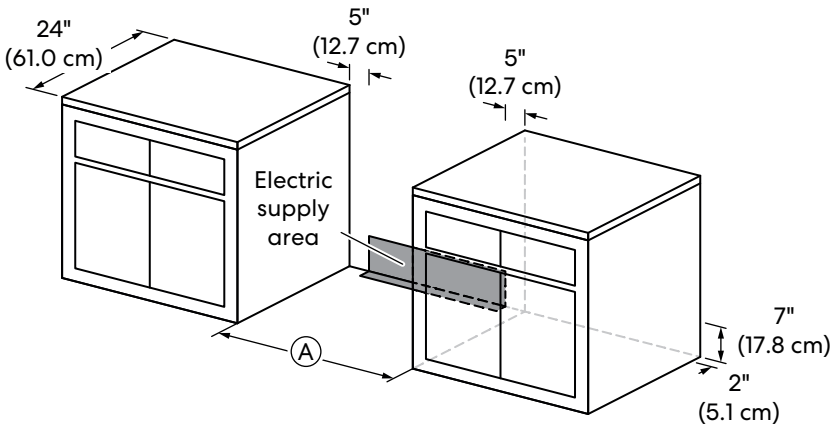

Model	A
	Horizontal Clearance
30" Models: COS-GRC304KB(-BK)	30" (76.2 cm)
36" Models: COS-GRC366KB(-BK)	36" (91.4 cm)
48" Models: COS-GRC488KB(-BK)	48" (121.9 cm)

VENTING REQUIREMENTS

IMPORTANT: This range must be exhausted outdoors unless you are using ductless venting. Observe all governing codes and ordinances. Do not obstruct flow of combustion and ventilation air.

- Do not terminate the vent system in an attic or other enclosed area.
- Use an approved vent cap for proper performance. If an alternate wall or roof cap is used, be certain the cap size is not reduced and that it has a backdraft damper.
- Vent system must terminate to the outside unless you are using a ductless vent kit.
- Rigid metal vent is recommended. For best performance, do not use plastic or metal foil vent.
- If a joist or stud must be cut, then a supporting frame must be constructed.
- The size of the vent should be uniform.
- The vent system must have a damper.
- Seal all joints in the vent system.
- Use caulking to seal exterior wall or roof opening around the cap.
- Determine which venting method is best for your application.

MAKEUP AIR

Local building codes may require the use of makeup air systems when using ventilation systems greater than specified CFM of air movement. The specified CFM varies from locale to locale. Consult your HVAC professional for specific requirements in your area.

ELECTRICAL REQUIREMENTS

WARNING



ELECTRICAL SHOCK HAZARD

- Do not use an extension cord with this appliance.
- Remove house fuse or open circuit breaker before beginning installation.

ELECTRICAL GROUNDING INSTRUCTIONS

- The power cord of this appliance is equipped with a three-prong (grounding) plug which plugs into a standard three-prong grounding wall receptacle to minimize the possibility of electric shock hazard.
- **DO NOT, UNDER ANY CIRCUMSTANCES, CUT OR REMOVE THE (THIRD) GROUNDING PRONG FROM THE PLUG.**

U.S.A. ONLY

Be sure that the electrical connection and wire size are adequate and in conformance with the National Electrical Code, ANSI/NFPA No. 70 - latest edition and all local codes and ordinances.

A copy of the above code standards can be obtained from:

National Fire Protection Association
1 Batterymarch Park
Quincy, MA 02169

CANADA ONLY

Be sure that the electrical connection and wire size are adequate and in conformance with the CSA Standard C22.1, Canadian Electrical Code, Part 1 - latest edition and all local codes and ordinances.

A copy of the above code standards can be obtained from:

Canadian Standards Association
178 Rexdale Blvd.
Toronto, ON M9W 1R3 CANADA

ELECTRICAL CONNECTION

WARNING: Improper connection of the equipment-grounding conductor can result in a risk of electric shock. Check with a qualified electrician or service technician if you are in doubt as to whether the appliance is properly grounded. Do not modify the power supply cord plug. If it will not fit the outlet, have a proper outlet installed by a qualified electrician.

- The receptacle of this range is to be connected to a properly grounded dedicated circuit providing 120 VAC/60 Hz power and protected by a 15- or 20-Amp circuit breaker or slow blow fuse. It is recommended that a separate circuit serving only this range be provided.
- Where a standard two-prong wall receptacle is encountered, contact a qualified electrician to have it replaced with a properly grounded three-prong wall receptacle.
- This range is equipped with an electronic ignition system that will not operate properly if plugged into an outlet that is not correctly polarized. Reverse polarity will result in continuous sparking of the electrodes, even after flame ignition.
- Electronic ignition systems operate within wide voltage limits, but proper grounding and polarity are necessary. Check that the outlet provides 120-volt power and is correctly grounded.
- Do not use an extension cord or an adapter plug.
- Check local codes and consult gas supplier. Check existing electrical supply and gas supply. It is recommended that all electrical connections be made by a licensed, qualified electrical installer.
- Range must be connected to the proper electrical voltage and frequency as specified on the model/serial/rating plate. The plate is located behind the oven door on the oven frame, and also on the back panel of the range. Refer to the illustrations in the "Location Requirements" section.
- It is the personal responsibility of the range owner to provide the correct electrical service for this range.
- This gas range is not required or recommended to be plugged into a GFCI (Ground-Fault Circuit Interrupter) outlet. It is recommended that you not plug an electric spark ignition gas range or any other major appliance into a GFCI wall outlet as it may cause the GFCI to trip during normal cycling.
- Performance of this range will not be affected if operated on a GFCI-protected circuit. However, occasional nuisance tripping of the GFCI breaker is possible due to the normal operating nature of electronic gas ranges.
- The wiring diagram is located on the back of the range.

GAS SUPPLY REQUIREMENTS

WARNING



FIRE AND EXPLOSION HAZARD

- Use a new CSA International approved gas supply line.
- Install a shut-off valve.
- Securely tighten all gas connections.
- If connected to LP, have a qualified person make sure gas pressure does not exceed the maximum pressure listed in this section.
- Examples of a qualified person include:
 - licensed heating personnel
 - authorized gas company personnel
 - authorized service personnel
- Failure to do so can result in death, explosion or fire.

IMPORTANT:

- Observe all governing codes and ordinances.
- This installation must conform with all local codes and ordinances. In the absence of local codes, installation must conform with American National Standard, National Fuel Gas Code ANSI Z223.1/NFPA 54 - latest edition, or in Canada, the Natural Gas and Propane Installation Code, CAN 1-1.1-M81 - latest edition.
- Leak testing of the range must be conducted according to the manufacturer's instructions. Do not use a flame to check for leaks.

TYPE OF GAS

This range has been design-certified according to ANSI Z21.1a, latest edition for use with Natural gas (NG) or, after proper conversion, for use with Propane (LP) gas.

Natural Gas

This range is factory-set for use with Natural gas (NG). The model/serial/rating plate located on the back panel of the range has information on the types of gas that can be used. If the types of gas listed do not include the type of gas available, check with the local gas supplier.

Propane Gas (LP) Conversion

The LP conversion kit is sold separately. Conversion must be performed by a qualified service technician. The qualified agency performing this work assumes the gas conversion responsibility. No attempt shall be made to convert the appliance from the gas specified on the model/serial/rating plate for use with a different gas without consulting the serving gas supplier.

GAS SHUT-OFF VALVE

A manual gas line shut-off valve must be installed in an easily accessible location. Do not block access to shut-off valve. The valve is for turning on or shutting off gas to the range.

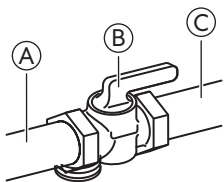

- Ⓐ Gas Supply Line
- Ⓑ Shutoff Valve "Open" Position
- Ⓒ To Range

GAS SUPPLY LINE

Provide a gas supply line of 3/4" (1.9 cm) rigid pipe to the range location. A smaller size pipe on longer runs may result in insufficient gas supply. Pipe-joint compounds that resist the action of LP gas must be used. With LP gas, piping or tubing size can be 1/2" (1.3 cm) minimum. Usually, LP gas suppliers determine the size and materials used in the system.

Flexible Metal Appliance Connector

- If local codes permit, a new CSA design-certified, 4 - 5 ft (122 - 152.4 cm) long, 1/2" (1.3 cm) or 3/4" (1.9 cm) I.D., flexible metal appliance connector may be used for connecting range to the gas supply line. In Canada, flexible connectors must be single wall metal connectors less than 6 feet (182.9 cm) in length.

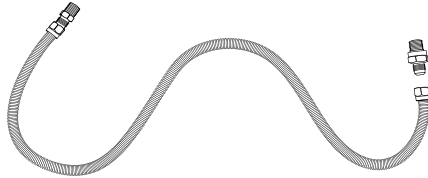

- A 1/2" (1.3 cm) male pipe thread is needed for connection to the female pipe threads of the inlet to the appliance pressure regulator.
- Do not kink or damage the flexible metal tubing when moving the range.

Rigid Pipe Connection

- Since the range must be pulled away from the installation space to provide access to the gas regulator connections, and because hard piping restricts movement of the range, the range can only be installed using a CSA International-certified flexible metal appliance connector.
- If local codes require a hard-piped connection, a combination of pipe fittings must be used to connect the range to the existing gas line and maintain an accessible working space behind the range. Consult with a qualified local technician for an optimal connection suitable for your installation.

GAS PRESSURE REGULATOR

The gas pressure regulator supplied with this range must be used. The inlet pressure to the regulator should be as follows for proper operation:

	Natural gas	LP gas
Minimum pressure	3.5" WC	8" WC
Maximum pressure	7" WC	11" WC

Contact local gas supplier if you are not sure about the inlet pressure.

Burner Input Requirements

Input ratings shown on the model/serial/rating plate are for elevations up to 2,000 ft (609.6 m).

For elevations above 2,000 ft (609.6 m), ratings are reduced at a rate of 4% for each 1,000 ft (304.8 m) above sea level (not applicable for Canada).

GAS SUPPLY PRESSURE TESTING

Gas supply pressure for testing regulator must be at least 1" (2.5 cm) water column pressure above the manifold pressure shown on the model/serial/rating plate.

Line pressure testing above 0.5 psi gauge (14" WCP)

The range and its individual shut-off valve must be disconnected from the gas supply piping system during any pressure testing of that system at test pressures in excess of 0.5 psi (3.5 kPa).

Line pressure testing at 0.5 psi gauge (14" WCP) or lower

The range must be isolated from the gas supply piping system by closing its individual manual shut-off valve during any pressure testing of the gas supply piping system at test pressures equal to or less than 1/2 psi (3.5 kPa).

INSTALLATION INSTRUCTIONS

IMPORTANT: This appliance shall be installed only by authorized persons and in accordance with the manufacturer's installation instructions, local gas fitting regulations, municipal building codes, electrical wiring regulations, local water supply regulations.

UNPACK RANGE

WARNING

EXCESSIVE WEIGHT HAZARD

- Use two or more people to move and install range. Failure to do so can result in back or other injury.

1. Remove shipping materials, tape and film from the range. Do not dispose of anything until the installation is complete.
2. Remove oven racks and parts package from oven and shipping materials.
3. Using 2 or more people, gently move range close enough but outside its final installation location to allow for final electrical connections.

NOTE:

- Do not remove any warning-type labels, the model/serial number label, or the Tech Sheet that is located on the back of the range.
- Do not use sharp instruments, rubbing alcohol, flammable fluids, or abrasive cleaners to remove tape or glue. These products can damage the surface of your range.
- Do not push or pull the range by grabbing the open oven door or cooktop only. Doing so can result in serious damage to the range.

NOTE:

- Do not lift the range using the cooktop or oven door handle. Doing so can cause damage and improper operation of the range.
- To reduce the weight of the range while being moved, adjusted, and installed, leave the cooktop grates, oven racks, and any other accessories to the side until they are ready to be installed later in these instructions.
- To further reduce the weight of the range while being moved, adjusted, and installed, detach the oven door from the range. See "Removing/Assembling Oven Door" section.

INSTALL REAR RUBBER PADS (OPTIONAL)

1. Locate the rubber pads and screws from the parts bag.
2. Install the rubber pads to the back panel of range. Do not overtighten.

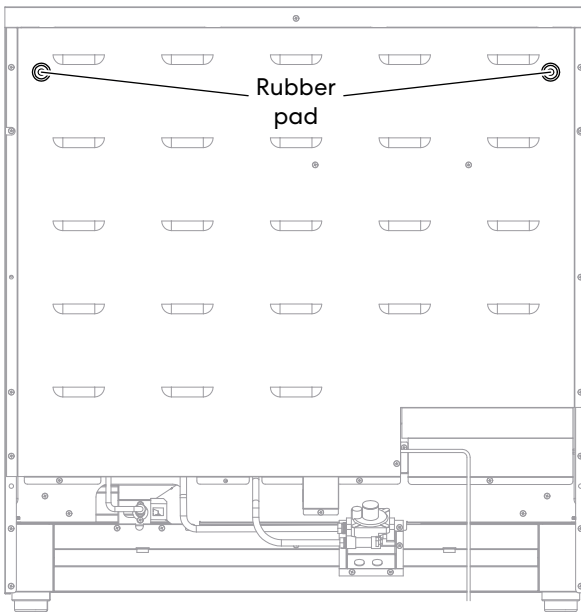

INSTALL ANTI-TIP DEVICE

WARNING



TIP OVER HAZARD

- A child or adult can tip the range and be killed.
- Install anti-tip bracket to floor or wall per installation instructions.
- Slide range back so rear range foot is engaged in the slot of the floor-mounting anti-tip bracket or rear range pin is engaged under the wall-mounting anti-tip bracket.
- Re-engage the anti-tip bracket if range is moved.
- Do not operate the range without anti-tip bracket installed and engaged.
- Failure to follow these instructions can result in death or serious burns to children and adults.

IMPORTANT:

- An anti-tip bracket is provided with the range.
- **Floor-mounting anti-tip bracket:**
 - The anti-tip bracket uses a rear range foot to secure the range to the floor.
 - Attach the anti-tip bracket to the floor so that the rear range foot will be centered within the bracket when the range is pushed into its final position.
- **Wall-mounting anti-tip bracket:**
 - The anti-tip bracket uses a pin near the rear bottom of the range to secure the range to the floor.
 - Attach the anti-tip bracket to the wall so that the pin near the rear bottom of the range will be centered below the arm of the anti-tip bracket when the range is pushed into its final position.

FLOOR-MOUNTING ANTI-TIP BRACKET (FOR 30" MODELS ONLY)

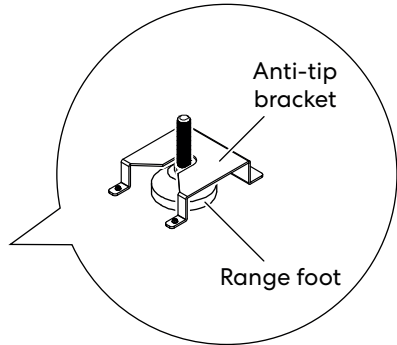
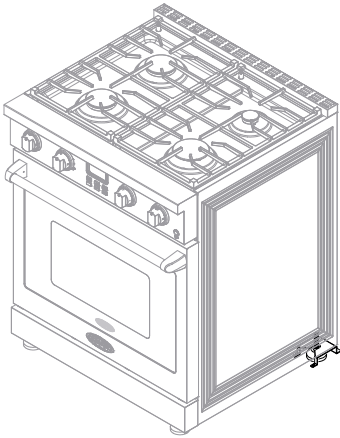

1. Locate and remove the anti-tip bracket and mounting screws from the parts bag.

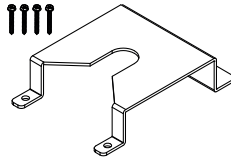

2. Locate the preferred location for installation of the anti-tip bracket and mark the location of the screw holes. Bracket may be installed at either the back-left or back-right corner of the installation space.

NOTE:

- Only one anti-tip bracket needs installed.

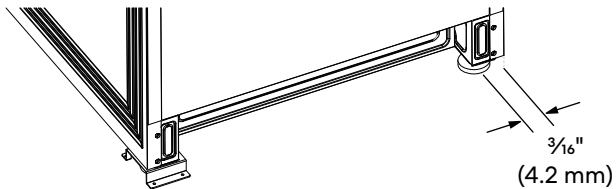

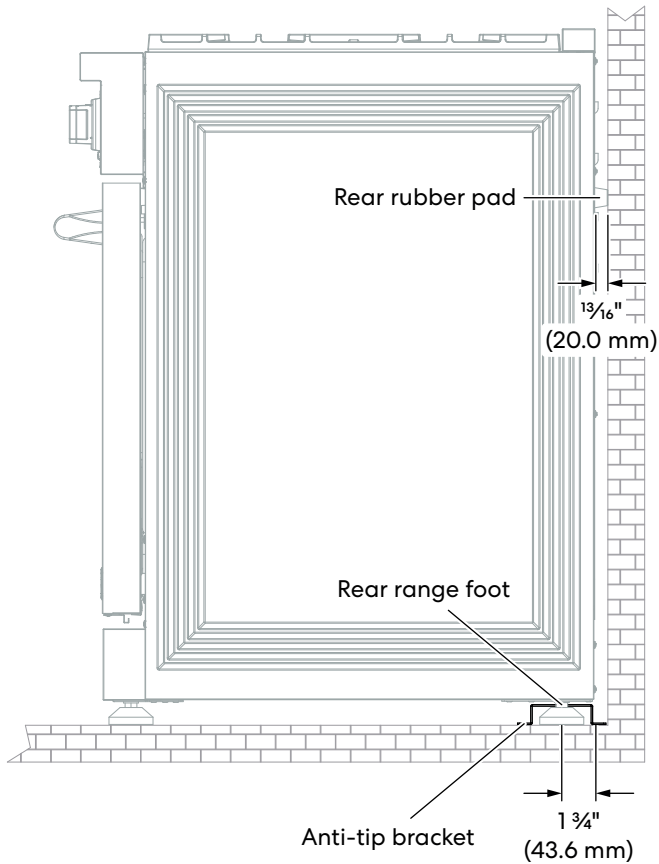

3. Follow the instructions specific to your construction.

Wood Construction

- Drill an appropriate hole where screws are to be located. Screw must enter wood.

Masonry Construction

- Due to the variety of masonry materials that may be present at installation site, hardware is not provided for attaching the anti-tip bracket to masonry. If bracket is to be mounted to masonry or ceramic floors, attach anti-tip bracket using two $5/16"$ OD sleeve anchors (with $1/4"$ bolt - either hex bolt head or hex nut head) rated for minimum 300lb tension for the masonry material present at installation site. Screw must enter masonry.

- Secure anti-tip bracket to floor with the screws provided.

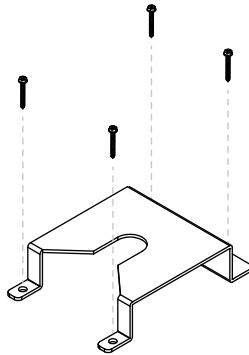

WALL-MOUNTING ANTI-TIP BRACKET (FOR 36" & 48" MODELS ONLY)

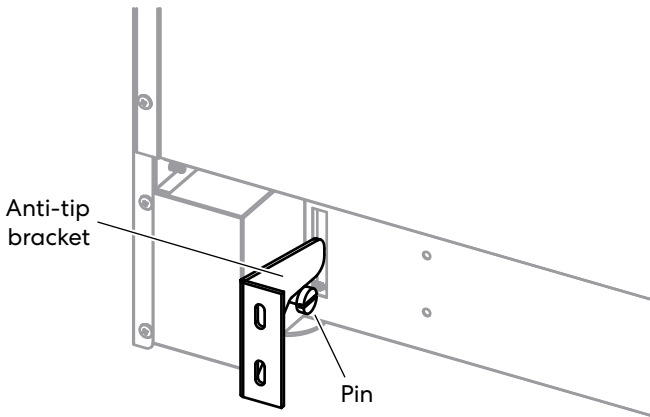

- Locate and remove the anti-tip bracket and mounting screws from the parts bag.

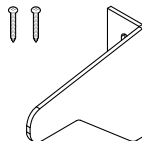

2. Locate the pin on the back of the range near the bottom corner.

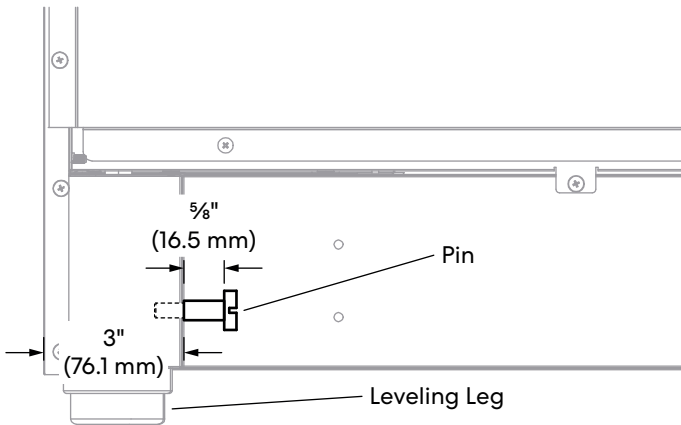

3. Locate the preferred location on the wall for installation of the anti-tip bracket. The pin must be engaged under the arm of anti-tip bracket when sliding range into final position.

- The top of the anti-tip bracket should be at least 4 1/4" (107 mm) above floor with the leveling legs fully contracted.
- The edge of the anti-tip bracket arm should be between 3" (76.1 mm) and 3 5/16" (90.6 mm) from the side panel of the range.

NOTE:

- Height given here is minimum clearance with the leveling legs of the range fully contracted. If the leveling legs are to be extended to level the cooking surface with the countertop, the anti-tip bracket position should also be raised by the same amount.
- It is recommended to adjust leveling legs as necessary first, then hold the anti-tip bracket level above the pin with the pin engaged under the arm, and measure the final height from the floor to the top of the anti-tip bracket.

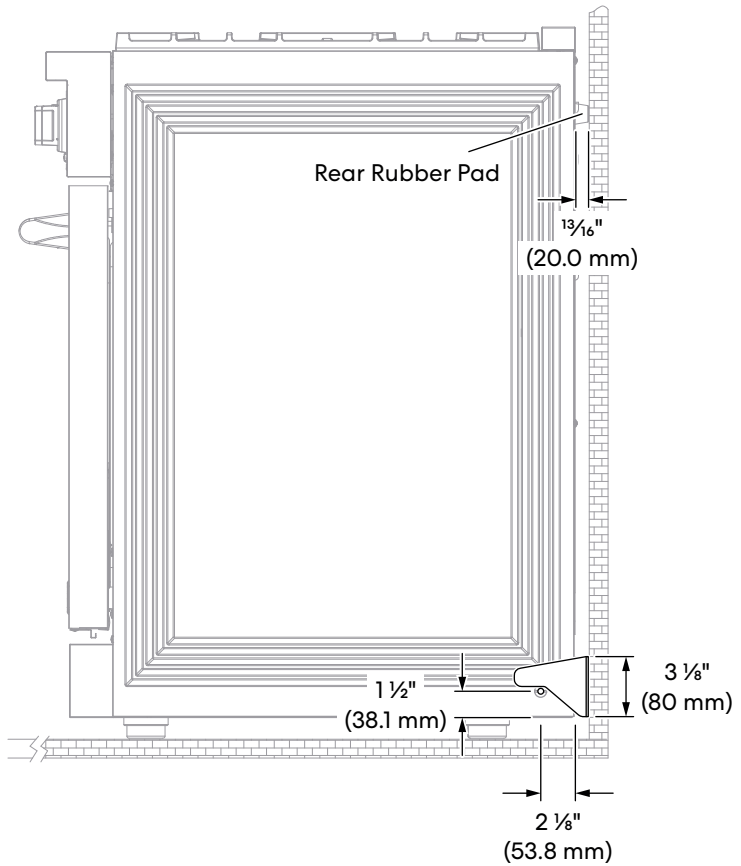

4. Mark the location of the anti-tip bracket screw holes on the wall.
5. Drill an appropriate hole where screws are to be located. Screw must enter wood.
6. Secure anti-tip bracket to wall with the screws provided.

INSTALL/REMOVE CONTROL KNOBS

Be very careful not to scratch the surface of the unit. The appearance of the knobs may vary from what are shown below.

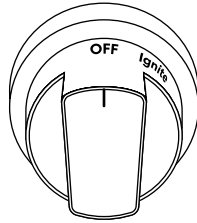

Cooktop control knob

30" Models: COS-GRC304KB(-BK)

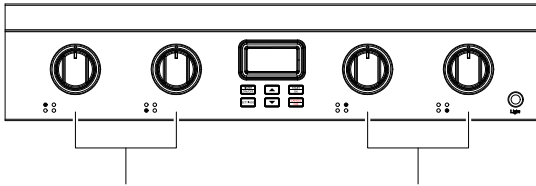

Cooktop control knobs

Cooktop control knobs

36" Models: COS-GRC366KB(-BK)

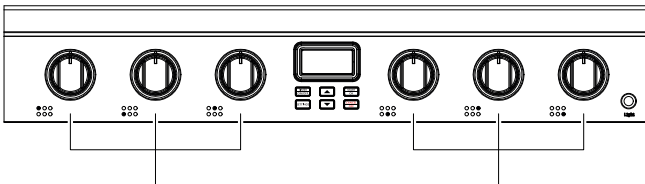

Cooktop control knobs

Cooktop control knobs

48" Models: COS-GRC488KB(-BK)

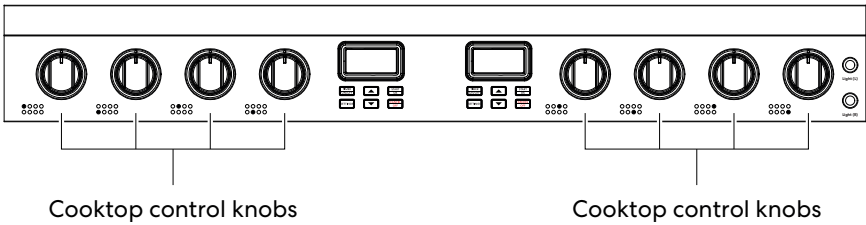

Installing the Control Knob

1. Hold the knob in an upright position with the OFF marking facing upward. Observe the open part centered on the back of the knob.
2. Place and align the open part on the back of the knob over the control stem that is sticking out of the control panel.
3. Press the knob onto the stem, and make sure the knob is in the OFF position.

Removing the Control Knob

1. Pull the knob straight off the stem.

INSTALL/REMOVE OVEN DOOR HANDLE

Be very careful not to scratch the surface of the unit. The appearance of the handle may vary from what is shown below, but the installation will be the same.

Tool Needed

- Hex key (provided)

Installing the Handle

1. Partially loosen the set screws in the handle end caps with the Hex key.

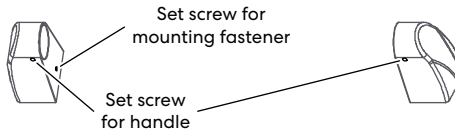

2. Attach handle end cap over each end of the handle, and slightly tighten the set screws for handle.

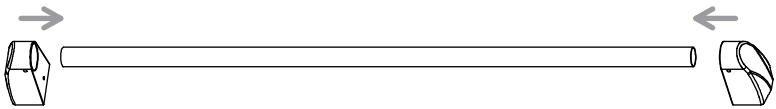

3. Place the handle on the door by fitting the handle end cap footprints over the mounting fasteners.

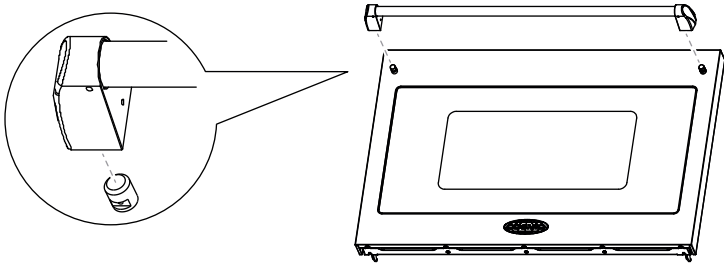

4. Tighten all set screws with the Hex key while supporting the handle.

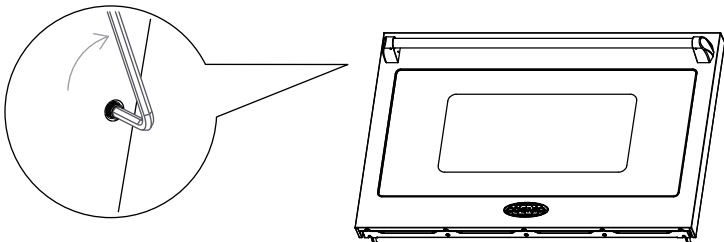

Removing the Handle

1. Locate the set screws for mounting fastener on the handle end caps.

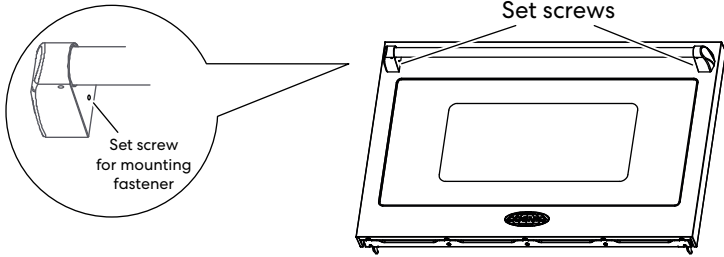

2. Loosen the set screw on one end with the Hex key while supporting the handle. Do not remove the set screw from the handle end cap.

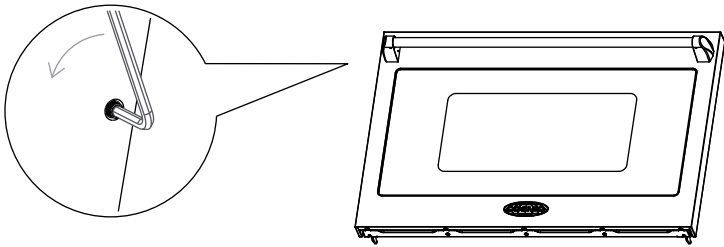

3. Keep supporting the handle while loosening the set screw on the other handle end cap.

4. Remove the handle from the mounting fasteners on the door and set aside.

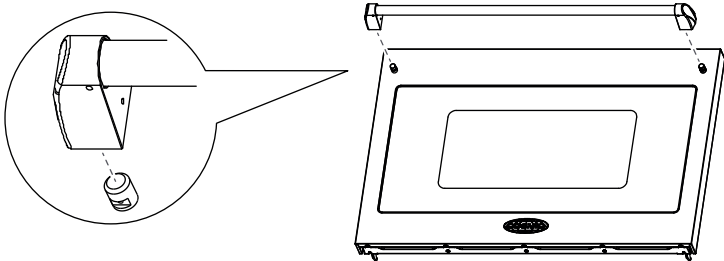

REMOVING/ASSEMBLING OVEN DOOR

For normal range use, it is not suggested to remove the oven door. However, if removal is necessary, make sure the oven is off and cool.

NOTE:

- The oven door is heavy.
- If door is removed, confirm that door operates correctly and seals properly when reinstalled. If door gasket does not seal completely, heat escaping from around doors could ignite cabinetry.

Removing Door

1. Fully open the oven door.
2. Unlock the hinge locks on both sides, rotating them as far toward the open door frame as they will go.
3. Firmly grasp both sides of the door.
4. Close the door to the removal position, which is approximately five degrees or 2-3 inches from being fully closed. If the position is correct, the hinge arms will move freely.
5. Lift door up and out until the hinge arms are clear of the slots.

IMPORTANT: Do not lift door by door handle.

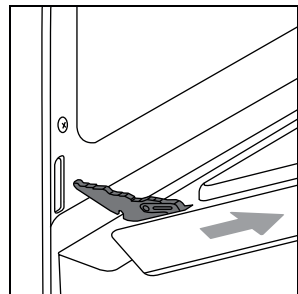
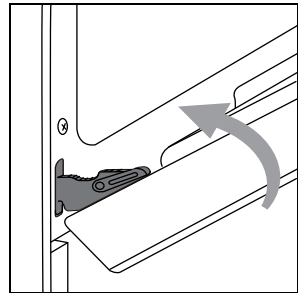
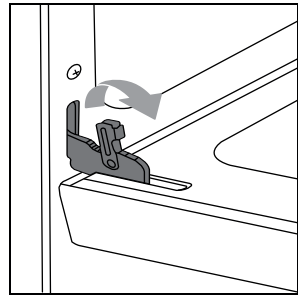

Assembling Door

1. Firmly grasp both sides of the door.
2. With the door at the same angle as the removal position, which is approximately five degrees or 2-3 inches from being fully closed, seat the indentation of the hinge arms into the bottom edge of the hinge slots. The notch in the hinge arms must be fully seated into the bottom edge of the slots.

IMPORTANT: Do not lift door by door handle.

3. Open the door fully. If the door will not open fully, the indentation is not seated correctly in the bottom edge of the slots.
4. Lock the hinge locks, rotating them back toward the slots in the oven frame until they lock.
5. Close the oven door. Check that the door is free to open and close and is level while closed.

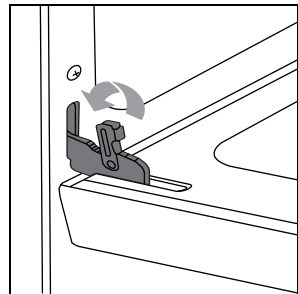
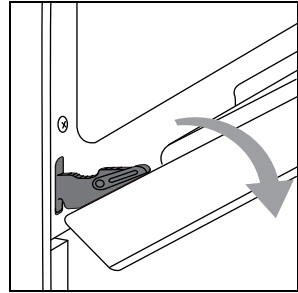
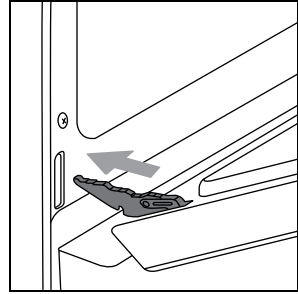

GAS CONNECTION

WARNING



FIRE AND EXPLOSION HAZARD

- Use a new CSA International approved gas supply line.
- Install a shut-off valve.
- Securely tighten all gas connections.
- If connected to LP, have a qualified person make sure gas pressure does not exceed the maximum pressure listed in the "Gas Supply Requirement" section.
- Examples of a qualified person include:
 - licensed heating personnel
 - authorized gas company personnel
 - authorized service personnel
- Failure to do so can result in death, explosion or fire.

This appliance shall be installed only by authorized persons and in accordance with the manufacturer's installation instructions, local gas fitting regulations, municipal building codes, electrical wiring regulations, local water supply regulations. The agency performing this work assumes responsibility for the quality of work performed, including checking for leaks and ensuring installation meets code requirements.

This range is factory-set for use with Natural gas. To use this range with Propane gas, see the "Gas Conversion" section before connecting this range to the gas supply. Gas conversions from Natural gas to Propane gas or from Propane gas to Natural gas must be done by a qualified installer.

The gas pressure regulator supplied with this range must be used. See "Gas Supply Requirements" section for more details.

TYPICAL FLEXIBLE CONNECTION

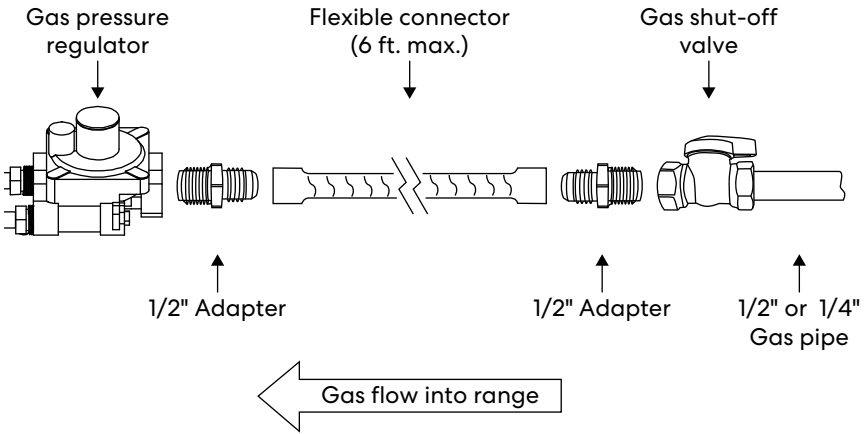

1. Make sure a manual gas line shut-off valve is installed in an easily accessible location.
2. Turn manual shut-off valve to the closed position.
3. Unplug range or disconnect power.
4. If present, remove the plastic cap at the regulator inlet on the back of the range.

IMPORTANT: Do not remove the gas pressure regulator.

30" & 36" Models: COS-GRC304KB(-BK), COS-GRC366KB(-BK)

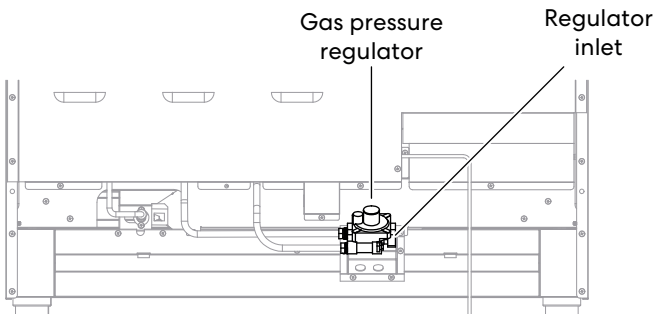

48" Models: COS-GRC488KB(-BK)

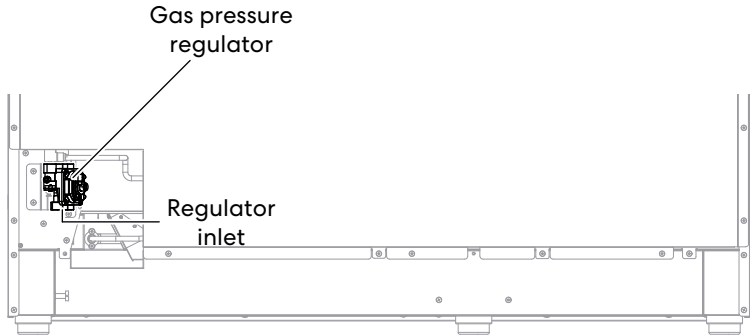

5. Apply pipe-joint compound made for use with NG/LP gas to the smaller thread ends of the flare union adapters.
6. Attach male 1/2" flare union adapter to the 1/2" NPT internal thread at the regulator inlet with a wrench using no more than 15 ft-lbs of torque. Use a backup wrench on the regulator fitting to avoid damage.

NOTE:

- Do not make connections to the gas regulator too tight. Overtightening may crack the regulator resulting in a gas leak and possible fire or explosion.

7. Attach male 1/2" or 3/4" flare union adapter to the NPT internal thread of the manual shut-off valve with a wrench using no more than 15 ft-lbs of torque, being certain not to move or turn the shut-off valve.
8. Connect one end of flexible gas supply line connector to the flare union adapter on the range.
9. Position range near the installation space to permit flexible gas supply line connection at the shut-off valve, and connect other end of flexible gas supply line connector to the flare union adapter at the shut-off valve. Check that flexible gas supply line is not kinked, and use wrenches to tighten flexible gas supply line connections.

TYPICAL RIGID PIPE CONNECTION

Since the range must be pulled away from the installation space to provide access to the gas regulator connections, and because hard piping restricts movement of the range, the range can only be installed using a CSA International-certified flexible metal appliance connector.

If local codes require a hard-piped connection, a combination of pipe fittings must be used to connect the range to the existing gas line and maintain an accessible working space behind the range. Hard-piped connections vary according to the supply line type, size and location. Consult with a qualified local technician for an optimal connection suitable for your installation.

CONVERT TO LP GAS (OPTIONAL)

This range is shipped from the factory set up to use natural gas. It can be converted to operate on propane gas (LP) by a qualified service technician.

The LP conversion kit is sold separately. The conversion to LP requires all surface and oven burner gas orifices to be changed. In addition, the gas pressure regulator must also be adjusted for LP.

See "Gas Conversion" section for detailed instructions.

To order LP conversion kit, see "Optional Parts" in the "Tools and Parts" section.

NOTE:

- All replaced orifices must be left with the consumer, including the instructions and retrofit sizes and orifice indication.

COMPLETE GAS CONNECTION

1. Check that all range controls are in the OFF position.
2. Open the manual shut-off valve in the gas supply line. The valve is open when the handle is parallel to the gas pipe.
3. Test all connections by brushing on an approved noncorrosive leak-detection solution. If bubbles appear, a leak is indicated. Correct any leak found.

COMPLETE INSTALLATION

ELECTRICAL CONNECTION

WARNING



ELECTRICAL SHOCK HAZARD

- Remove house fuse or open circuit breaker to disconnect power before servicing.
- Plug into a grounded 3-prong outlet.
- Do not use an adapter or an extension cord.
- Failure to do so can result in death, fire, or electrical shock.

IMPORTANT:

- The power cord of this appliance is equipped with a three-prong (grounding) plug which plugs into a standard three-prong grounding wall receptacle.
 - Where a standard two-prong wall receptacle is encountered, contact a qualified electrician to have it replaced with a properly grounded three-prong wall receptacle.
 - **DO NOT, UNDER ANY CIRCUMSTANCES, CUT OR REMOVE THE (THIRD) GROUNDING PRONG FROM THE PLUG.**
 - Before connecting the appliance to the power supply, make sure that the voltage and frequency listed on the rating label correspond with the household electrical supply. This data must correspond to prevent appliance damage. Consult an electrician if in doubt. It is the personal responsibility of the oven owner to provide the correct electrical service for this oven.
 - Do not use an extension cord or an adapter plug.
1. Check that all range controls are in the OFF position. Plug in range to a grounded 3-prong wall receptacle.

PLACEMENT AND LEVELING RANGE

WARNING

EXCESSIVE WEIGHT HAZARD

- Use two or more people to move and install range. Failure to do so can result in back or other injury.

CAUTION

LACERATION, FOREIGN OBJECT, CRUSH HAZARD

- When installing, moving, or servicing any appliance, wear proper protective equipment, including cut resistant gloves, steel-toed shoes, and safety glasses.

IMPORTANT:

- Do not lift by the oven door handle or control knobs. Push, pull, or lift only on the body or structural areas, such as oven, oven face, or back corners of range.
- Do not move unit by pushing or pulling on the door or control panel. Grasp the left/right door area to push the unit.
- Move range by lifting, not sliding, to prevent damage to floors.
- Use a belt when moving the range to prevent damaging the floor, or use cardboard, plywood, or stiff plastic to protect floors if sliding is necessary.
- Be careful not to pinch or kink the gas or electrical connection. If unit does not move in smoothly, check for obstructions. Do not attempt to force the unit into position.

Getting the unit properly placed in the installation space and level may require multiple attempts. It is recommended to measure and adjust leveling legs carefully before placing into the installation space, as the leveling legs may be difficult to adjust once the range is in its final position.

1. Use tape measure to measure from the floor to the top of the countertop at all four corners of the installation space.
2. While range is still positioned outside the installation space, use a plier or wrench to adjust the leveling leg at each corner so that the distance from the floor to the underside of the cooktop edge matches the dimensions measured in the installation space.
3. Using 2 or more people, gently move range into its final installation location and make sure rear range foot is engaged with the floor-mounting anti-tip bracket or rear pin is engaged under the arm of wall-mounting anti-tip bracket, being careful not to damage countertops, floor, or appliance.
4. Check to ensure the flexible metal gas connector and electrical cord are not kinked.
5. Place the level diagonally on the oven bottom or oven rack, and check each diagonal direction for level. Adjust the leveling legs as necessary.

NOTE:

- The range must be level for optimum cooking and baking performance.

6. Reassemble oven door and insert oven racks if they were previously removed. See "Removing/Assembling Oven Door" section.

VERIFY ANTI-TIP BRACKET ENGAGEMENT

Do not operate the range if its rear foot is not engaged in the slot of the floor-mounting anti-tip bracket or its rear pin is not engaged under the arm of wall-mounting anti-tip bracket.

IMPORTANT: If the range is pulled away from the wall for any reason, always verify anti-tip bracket engagement again.

1. Place the outside of your foot against the bottom of the front panel to keep the range from moving, and then grasp the back of the range, as shown.

2. Carefully and slowly attempt to tilt the range forward.

- If you encounter immediate resistance, the rear foot or the rear pin is engaged with the anti-tip bracket. Skip Steps 3 and 4 below.
- If the rear of the range lifts more than 1/2" (1.3 cm) off the floor without resistance, stop tilting the range and lower it gently back to the floor. The rear foot or the rear pin is not engaged with the anti-tip bracket. Proceed to Steps 3 and 4.

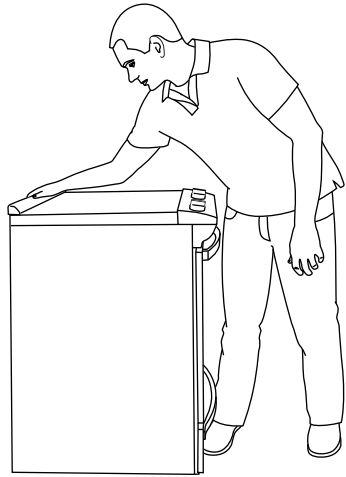

IMPORTANT: If there is a snapping or popping sound when tilting the range, the range may not be fully engaged with the anti-tip bracket. Check to see if there are obstructions keeping the range from sliding to the wall or keeping the rear foot or the rear pin from engaging with the bracket. Verify that the bracket is held securely in place by the mounting screws.

3. Slide the range forward, and verify that the anti-tip bracket is securely attached to the floor or the wall.
4. Slide range back so the rear foot or the rear pin is engaged with the anti-tip bracket.

ASSEMBLING THE SURFACE BURNERS AND GRATES

IMPORTANT: Do not operate the burners without all parts in place.

1. Check that all range controls are in the OFF position.
2. If the surface burner bases and caps are not already installed, remove them from package containing parts.
3. Align and place the burner bases and caps in the correct locations.

30" Models: COS-GRC304KB(-BK)

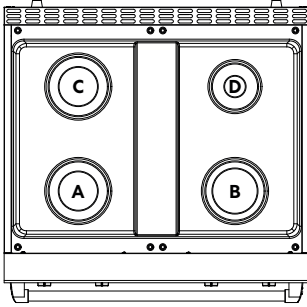

- A. Rapid (Medium)
- B. Super Rapid (Large)
- C. Semi Rapid (Medium)
- D. Auxiliary (Small)

36" Models: COS-GRC366KB(-BK)

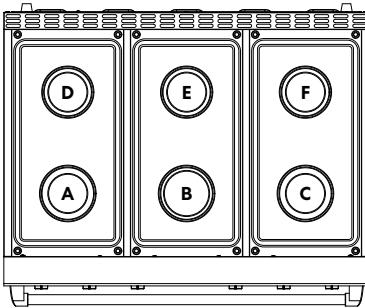

- A. Rapid (Medium)
- B. Super Rapid (Large)
- C. Rapid (Medium)
- D. Semi Rapid (Medium)
- E. Rapid (Medium)
- F. Semi Rapid (Medium)

48" Models: COS-GRC488KB(-BK)

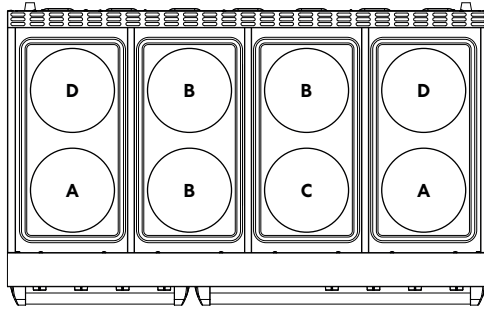

A. Super Rapid (Large)

B. Rapid (Medium)

C. Dual Ring

D. Semi Rapid (Medium)

NOTE:

- Align notches in burner caps with pins in burner base.
- Make sure the hole in the burner base is positioned over the igniter.
- Burner caps should be level when properly positioned. If burner caps are not properly positioned, surface burners will not light.
- The burner cap should not rock or wobble when properly aligned.

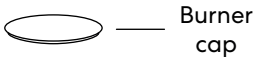

— Burner cap



— Burner base



— Orifice holder



Correctly positioned

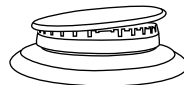

Incorrectly positioned

4. Remove any packaging materials on burner grates if present, and place burner grates over burner bases and caps.

NOTE:

- The burner grates must be properly positioned before cooking. Improper installation of the grates may result in scratching of the cooktop and/or poor combustion.

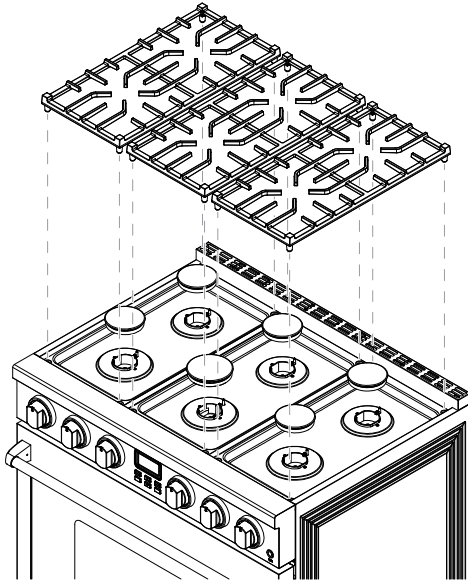

CHECKING OPERATION OF THE SURFACE BURNERS

Cooktop burners use electronic igniters. When the cooktop control knob is turned to the ignite position, the system creates a spark to light the burner. All or some other cooktop burners will spark, but only the burner with the control knob turned to the ignite position will produce a flame. This sparking continues as long as the control knob is turned to the ignite position.

STANDARD SURFACE BURNERS

The appearance of the knobs may vary from what are shown below.

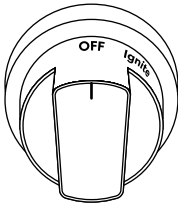

OFF position

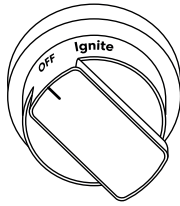

Ignite position

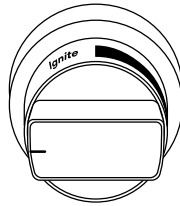

Max. position

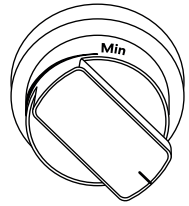

Min. position

1. For each burner, one at a time, push in and turn control knob to the ignite position, and turn control knob to the highest setting after the burner is lit.
2. The flame should light within 4 seconds. The first time a burner is lit, it may take longer than 4 seconds to light because of air in the gas line.
3. For each burner, one at a time, rotate the knob quickly to the lowest setting - confirm that the flame is not extinguished.
4. With one burner still at the lowest setting (and all others at highest setting), quickly open and close the oven door - confirm that the flame is not extinguished.
5. Compare flame height at the highest and lowest setting - confirm flame height is sufficiently reduced when turned to the lowest setting.

QUALITY OF FLAMES

The combustion quality of the burner flames needs to be confirmed visually.

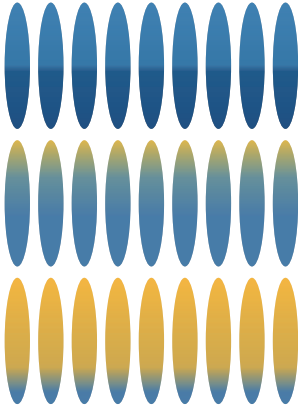

Soft blue flames

This is normal for natural gas.

Yellow tips on outer cones

This is normal for LP gas.

Yellow flames

This is abnormal for any gas operation.
Call for service.

If Burners Do Not Light Properly:

1. Turn cooktop control knob to the OFF position.
2. Check that the range is plugged into a grounded 3 prong outlet. Check that the circuit breaker has not tripped or the fuse has not blown.
3. Check that the gas shut-off valves are set to the open position.
4. Check that burner caps are properly positioned on burner bases.

Repeat start-up. If a burner does not light at this point, turn the control knobs to the OFF position and contact your dealer or authorized service company for assistance.

ABNORMAL OPERATION

ANY OF THE FOLLOWING ARE CONSIDERED TO BE ANBORMAL OPERATION AND MAY REQUIRE SERVICING:

- Yellow burner flames.
- Sooting up of cooking utensils.
- Burners not igniting properly.
- Burners failing to remain lit.
- Burners extinguished by oven door.
- Gas valves, which are difficult to turn.

IN CASE THE APPLIANCE FAILS TO OPERATE CORRECTLY, CONTACT THE AUTHORIZED SERVICE PROVIDE IN YOUR AREA.

THE BURNERS REQUIRE NO REGULATION OF THE PRIMARY AIR.

CHECKING OPERATION OF THE OVEN

Oven burners do not require any adjustment.

NOTE:

- Ensure door is closed, all packaging is removed, and oven is empty except for oven rack(s).

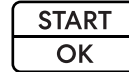
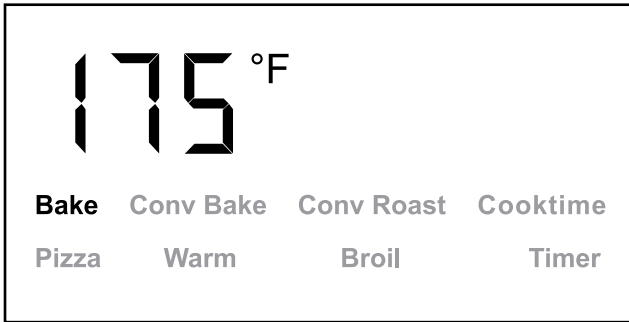

To Check Bake Burner:

1. Keep the oven door closed. The oven burners will turn off when oven door is open.
2. Press ▲ or ▼ repeatedly to select Bake mode, and press **START/OK**.
3. Press/Hold ▼ to adjust bake temperature setting to 175°F while it is flashing, and press **START/OK**.

4. Press **START/OK** to skip cook time setting and start the oven.
 - After a couple minutes when the oven temperature reaches above 100°F, the temperature on the display will begin to rise and show the current oven temperature.
 - Confirm that display shows temperature increasing.

5. Allow Bake mode to continue until oven has preheated to 175°F.
 - Confirm that preheat signals when temperature is reached.
 - Open the oven door temporarily. Without touching the oven bottom, confirm that heat can be felt radiating from the oven bottom and close the oven door.

6. Press **CANCEL/OFF** to stop Bake mode.

To Check Broil Burner:

1. Keep the oven door closed. The oven burners will turn off when oven door is open.

2. Press ▲ or ▼ repeatedly to select Broil mode, and press **START/OK**.

3. Press ▲ or ▼ to adjust broil setting to Hi or Lo while it is flashing, and press **START/OK** to start the oven.
 - After 30-60 seconds, the upper broil burner should light and can be visually seen through the oven door window.

4. Press **CANCEL/OFF** to stop Broil mode.

GAS CONVERSION

WARNING



FIRE AND EXPLOSION HAZARD

- Use a new CSA International approved gas supply line and install a shut-off valve for new installations.
- Securely tighten all gas connections.
- If connected to LP, have a qualified person make sure gas pressure does not exceed the maximum pressure listed in the "Gas Supply Requirement" section.
- Examples of a qualified person include:
 - licensed heating personnel
 - authorized gas company personnel
 - authorized service personnel
- Failure to do so can result in death, explosion or fire.

WARNING



TIP OVER HAZARD

- A child or adult can tip the range and be killed.
- Install anti-tip bracket to floor or wall per installation instructions.
- Slide range back so rear range foot or rear range pin is engaged with the floor-mounting or wall-mounting anti-tip bracket.
- Re-engage the anti-tip bracket if range is moved.
- Do not operate the range without anti-tip bracket installed and engaged.
- Failure to follow these instructions can result in death or serious burns to children and adults.

This range is factory-set for use with Natural gas (NG). The Propane gas (LP) conversion kit is sold separately. To order LP conversion kit, see "Optional Parts" in the "Tools and Parts" section.

IMPORTANT: Gas conversions must be done by a qualified service technician in accordance with the manufacturer's instructions and all codes and requirements of the authority having jurisdiction. The qualified agency performing this work assumes the gas conversion responsibility.

Keep and store the regulator cap that has just been replaced in case of re-installation with another gas.

CONVERT GAS PRESSURE REGULATOR

1. Turn manual gas shut-off valve to the closed position.
2. Unplug range or disconnect power.
3. Locate the regulator cap for correct fuel type being used.

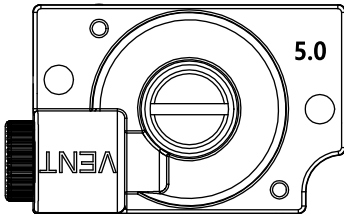

NG regulator cap

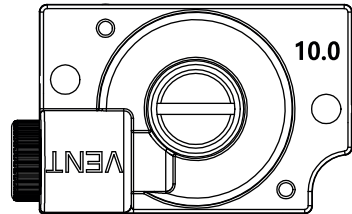

LP regulator cap

NOTE:

- **NG:** This range is factory-set with the NG regulator cap installed. If converting back for NG from LP, retrieve the NG regulator cap removed and stored from previous conversion.
- **LP:** Locate the LP regulator cap from LP conversion kit.

4. Locate gas pressure regulator at rear of range.

30" & 36" Models: COS-GRC304KB(-BK), COS-GRC366KB(-BK)

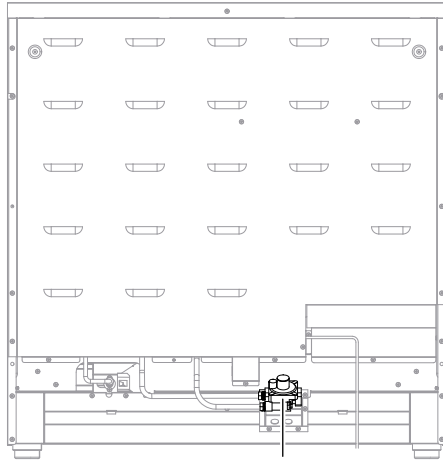

Gas pressure
regulator

48" Models: COS-GRC488KB(-BK)

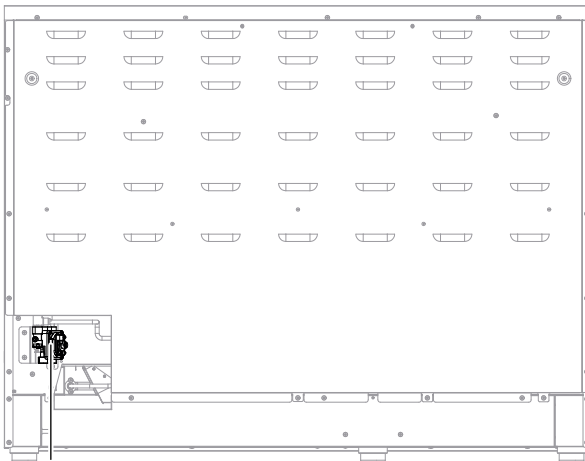

Gas pressure
regulator

5. Remove 2 screws near center of gas pressure regulator, and remove regulator cap.

IMPORTANT: Do not remove the gas pressure regulator. Keep the sealing gasket in place on the gas pressure regulator.

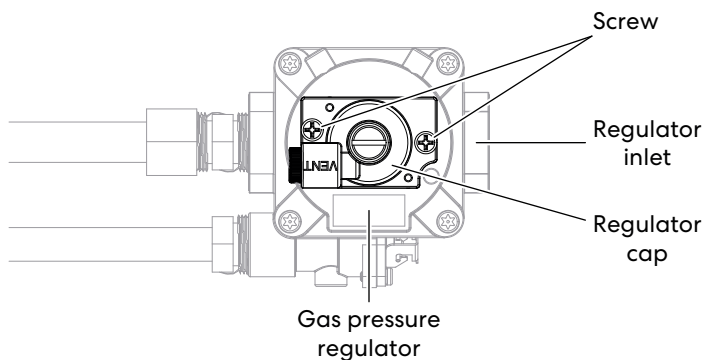

6. Replace the regulator cap for correct fuel type being used.

IMPORTANT: Keep and store the regulator cap that has just been replaced in case of re-installation with another gas.

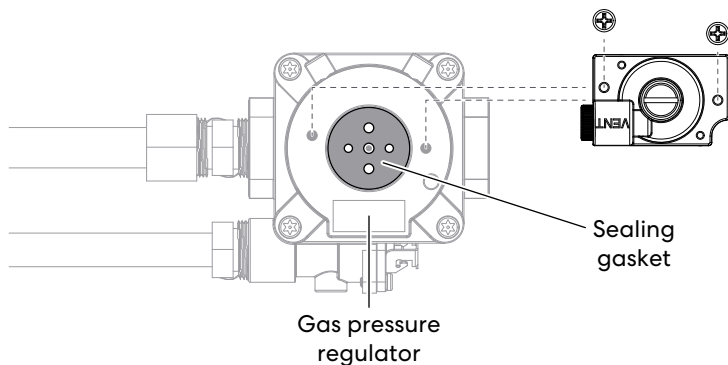

NOTE:

- If converting to propane from natural gas, please apply a label sticker with "LP Converted" notice on or near the regulator cover. If converting back to natural gas from propane, please remove the sticker so others know the appliance is set to use natural gas.

CONVERT SURFACE BURNERS

Tool Needed

- 9/32" (7 mm) nut driver

NG/LP Orifice Chart for Surface and Oven Burners

30" Models: COS-GRC304KB(-BK)

Burner Placement	NG Orifice Size (mm)	LP Orifice Size (mm)	Rating (BTU/h)
Front Left	1.57	1.03	12,000
Front Right	1.97	1.28	18,000
Rear Left	1.36	0.91	9,000
Rear Right	0.85	0.58	3,500
Oven Top	1.56	1.01	NG: 12,000 / LP: 10,000
Oven Bottom	1.90	1.18	18,500

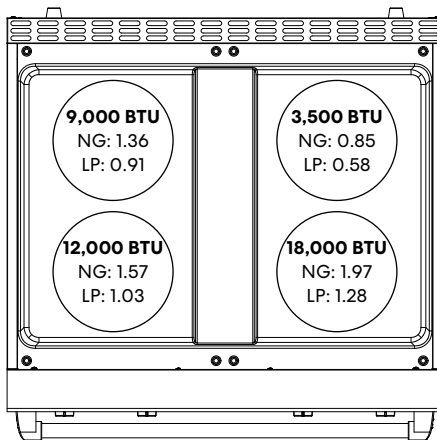

NG/LP Orifice Chart for Surface and Oven Burners

36" Models: COS-GRC366KB(-BK)

Burner Placement	NG Orifice Size (mm)	LP Orifice Size (mm)	Rating (BTU /h)
Front Left	1.57	1.03	12,000
Front Middle	1.97	1.28	18,000
Front Right	1.57	1.03	12,000
Rear Left	1.36	0.91	9,000
Rear Middle	1.57	1.03	12,000
Rear Right	1.36	0.91	9,000
Oven Top	1.62	1.01	NG: 13,500 / LP: 12,000
Oven Bottom	1.90	1.21	NG: 18,500 / LP: 16,000

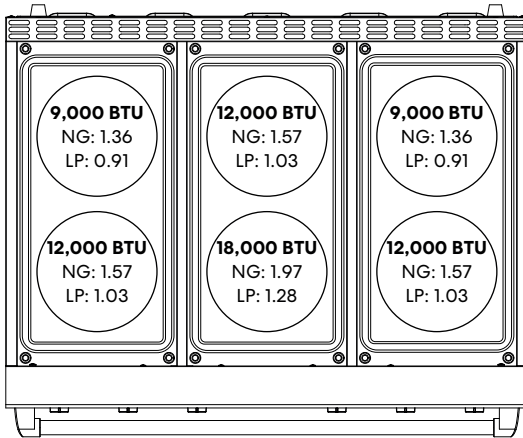

NG/LP Orifice Chart for Surface and Oven Burners

48" Models: COS-GRC488KB(-BK)

Burner Placement	NG Orifice Size (mm)	LP Orifice Size (mm)	Rating (BTU /h)
Front Left	1.97	1.28	18,000
Front Middle Left	1.57	1.03	12,000
Front Middle Right	2.09 + 0.78	1.21 + 0.50	NG: 22,000 / LP: 20,000
Front Right	1.97	1.28	18,000
Rear Left	1.36	0.93	9,500
Rear Middle Left	1.57	1.03	12,000
Rear Middle Right	1.57	1.03	12,000
Rear Right	1.36	0.93	9,500
Main Oven Top	1.66	1.01	NG: 13,500 / LP: 12,000
Main Oven Bottom	2.20	1.35	22,000
Sub Oven Bottom	1.66	1.10	14,000

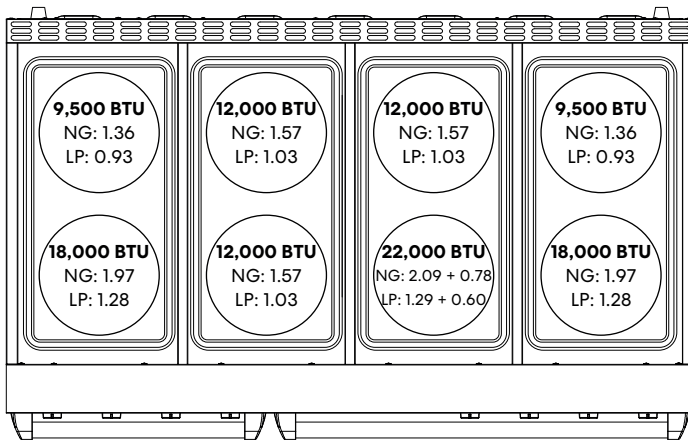

1. If installed, remove burner grates, burner caps, and burner bases.

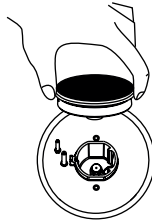

2. Remove the existing orifices with a 9/32" (7 mm) nut driver.

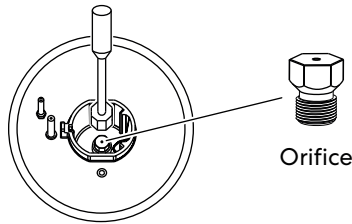

3. Replace the orifices with the correct fuel type orifices. Gas orifices are stamped with a size number. Refer to the orifice chart earlier for correct Natural gas (NG) and Propane gas (LP) orifice sizes and proper placement.

IMPORTANT: Keep and store the orifices that have just been replaced in case of re-installation with another gas.

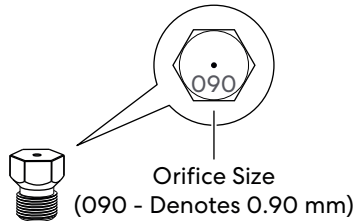

4. Replace the burner bases, burner caps, and burner grates. See "Assembling the Surface Burners and Grates" section.

NOTE:

- Align notches in burner caps with pins in burner base.
- Make sure the hole in the burner base is positioned over the igniter.
- Burner caps should be level when properly positioned. If burner caps are not properly positioned, surface burners will not light.
- The burner cap should not rock or wobble when properly aligned.

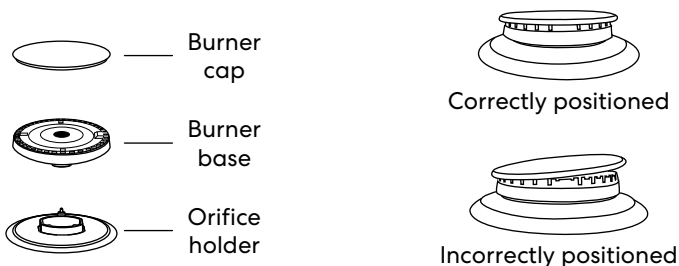

CONVERT OVEN BURNERS

This product cannot be converted to Natural gas (NG) or Propane gas (LP) by adjusting or tightening the oven orifices. The orifices must be replaced.

Be very careful not to scratch the surface of the oven cavity. To gain better access to the oven components, the oven door may be detached from the range. See "Removing/Assembling Oven Door" section.

Tool Needed

- 3/8" (9.5 mm) combination wrench

IMPORTANT: Make sure to save the orifices that have just been replaced in the conversion.

Converting Broil Burner

1. Empty the oven.
2. Remove the 4 screws from broil burner baffle at the oven top.
3. Remove the 3 screws from broil burner while supporting it.
4. Carefully remove broil burner assembly (burner, igniter, and baffle) from broil orifice holder.
5. Tip front of assembly downwards and lean assembly out of the way, being careful not to damage igniter wire or oven surfaces.
6. Using a 3/8" (9.5 mm) combination wrench, replace the broil orifice with the correct fuel type orifice. Gas orifices are stamped with a size number. Refer to the orifice chart earlier for correct NG and LP gas orifice sizes.
7. Place broil burner gas inlet on broil orifice holder and align burner assembly with the top and the rear of the oven. Make sure igniter wire is properly inserted into rear hole.
8. Replace the screws on burner assembly.

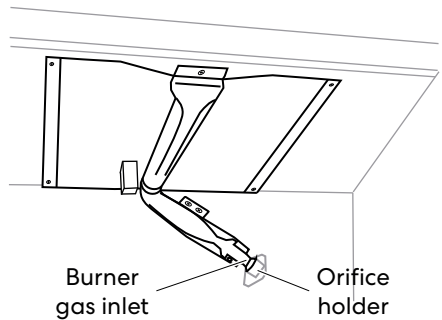
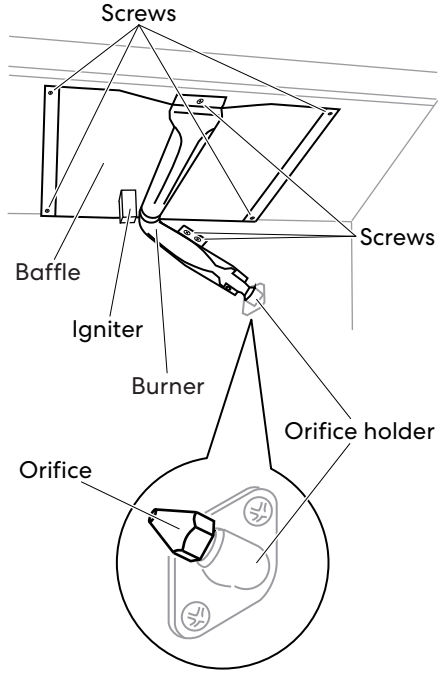

Converting Bake Burner

1. Lift and remove bake burner cover on the oven bottom.
2. Remove the screw in the middle of lower heat shield on the right, and pull out rear heat shield plate to unveil bake orifice holder.
3. Remove the 3 screws from bake burner.
4. Gently move burner to the left and away from bake orifice holder, being careful not to damage igniter wire.
5. Using a 3/8" (9.5 mm) combination wrench, replace the bake orifice with the correct fuel type orifice. Gas orifices are stamped with a size number. Refer to the orifice chart earlier for correct NG and LP gas orifice sizes.
6. Place bake burner gas inlet on bake orifice holder and align burner with the oven. Make sure igniter wire is properly inserted into rear hole, and replace the screws on burner.
7. Replace the rear heat shield plate, the bake burner cover.
8. **For 48" Models Only** – Repeat the above converting bake burner steps for sub oven.

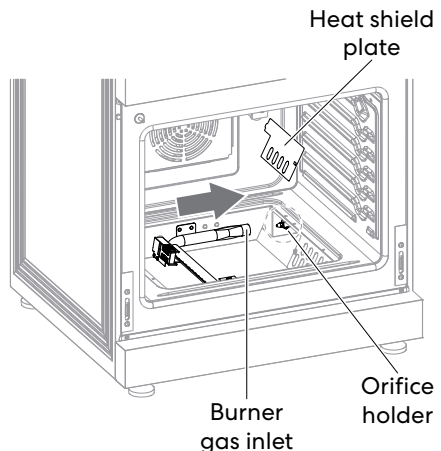
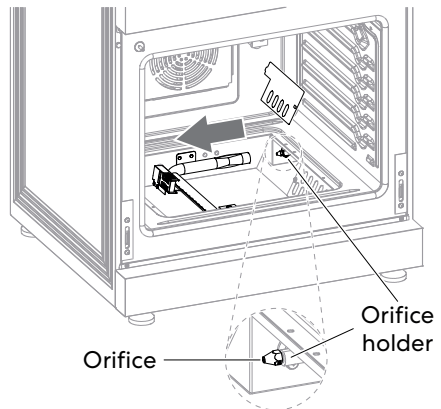
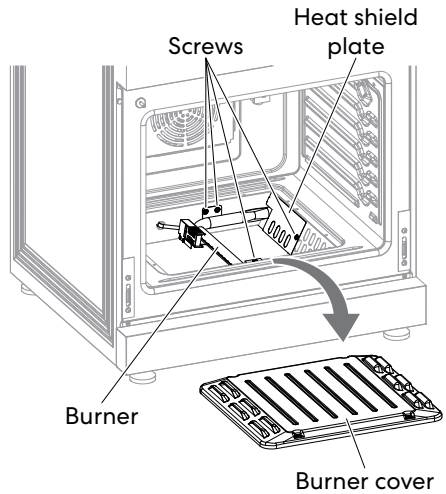

Converting Sub Oven Bake Burner (For 48" Models Only)

1. Remove the 16 screws along edges and across center of rear range panel.

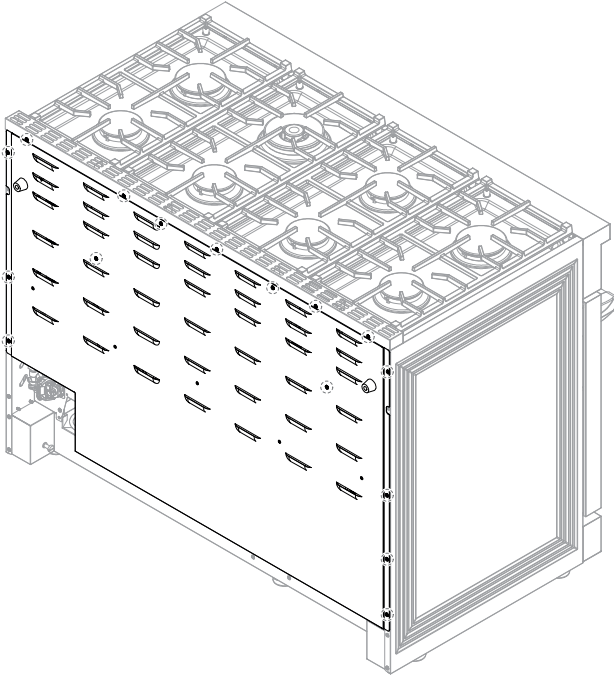

2. Loosen the support screws on both sides and remove rear range panel.

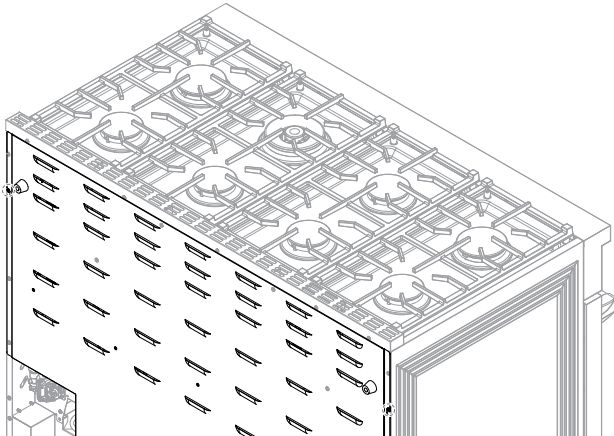

3. Remove the screws from bake burner orifice holder. The orifice is located behind the orifice holder.

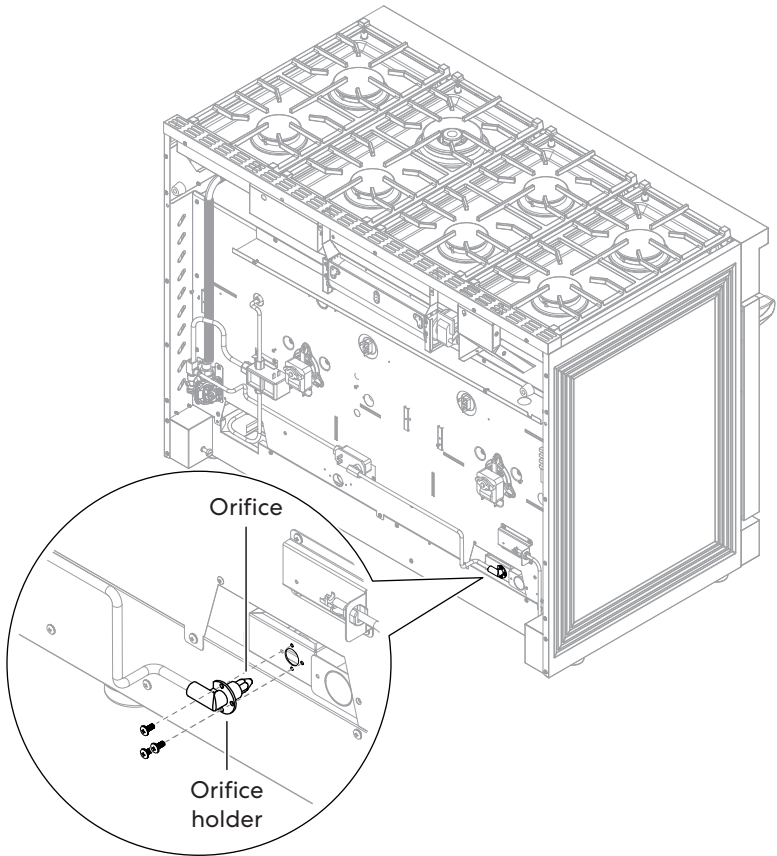

4. Using one wrench to hold orifice holder and a 3/8" (9.5 mm) combination wrench to turn and remove orifice, being careful not to damage gas pipe.
5. Replace the orifice with the correct fuel type orifice.
 - Gas orifices are stamped with a size number. Refer to the orifice chart earlier for correct Natural gas and LP gas orifice sizes.
6. Place orifice holder back in position and replace the screws.
7. Place rear range panel back in position and replace the screws.

ADJUST SURFACE BURNER VALVES

Be very careful not to scratch the surface of the unit.

Tool Needed

- Slotted (flat-head) screwdriver

1. Remove the surface burner knobs by pulling the knobs straight off the stem.

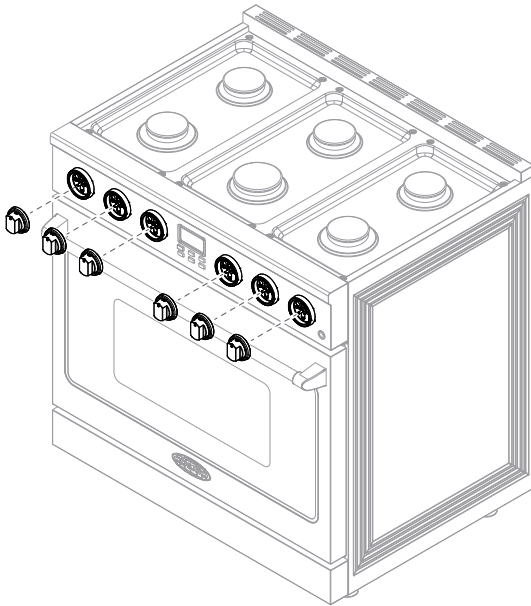

2. Locate the adjustment screw of burner valve next to the stem.

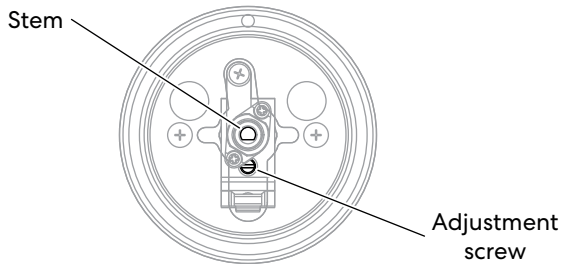

3. Tighten the adjustment screw to the correct fuel type position.

Standard Burner Valves

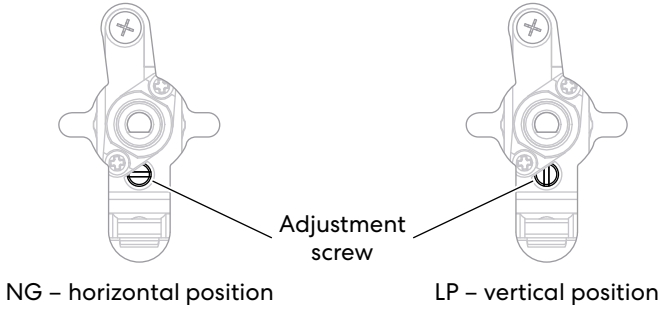

Dual-Ring Burner Valves (For 48" Models Only)

- Remove the bezel temporarily to access the adjustment screws.

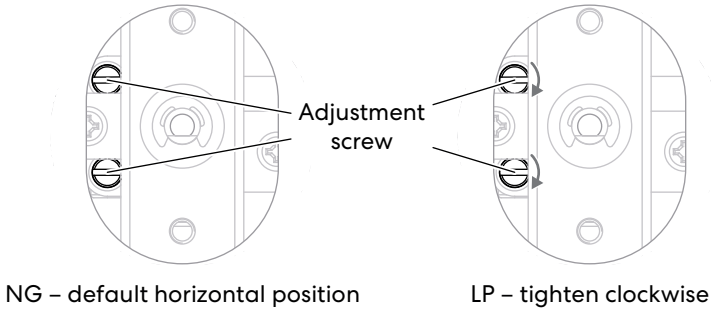

4. Replace the knobs. See "Install/Remove Control Knobs" section.

COMPLETE GAS CONVERSION

1. Open shut-off valve in the gas supply line.
 - Refer to "Gas Connection" in the "Installation Instructions" section for proper connection of the range to the gas supply.
2. Plug in range or reconnect power, and carefully move range into its final installation location.
 - Refer to the "Complete Installation" section to complete this procedure.

IMPORTANT

Do Not Return This Product to The Store

If you have a problem with this product, please contact Customer Support at

+1 (888) 784-3108

Dated proof of purchase, model #, and serial # required for warranty service.

IMPORTANT

Ne pas Réexpédier ce Produit au Magasin

Pour tout problème concernant ce produit, veuillez contacter le service des consommateurs Customer Support au

+1 (888) 784-3108

Une preuve d'achat datée est requise pour bénéficier de la garantie.

IMPORTANTE

No regrese este producto a la tienda

Si tiene algún problema con este producto, por favor contacte el ayuda al cliente al

+1 (888) 784-3108

(Válido solo en E.U.A.)

Necesita una prueba de de compra fechada, número de modelo y de serie para el servicio de la garantía.



Correct disposal of this product:

This marking indicates that this appliance should not be disposed with other household wastes. To prevent possible harm to the environment or human health from uncontrolled waste disposal, recycle it responsibly to promote the sustainable reuse of material resources.

MEMO

A series of horizontal dashed lines for writing.

MEMO

A series of horizontal dashed lines for writing.



APPLIANCES

Cosmo is constantly making efforts to improve the quality and performance of our products, so we may make changes to our appliances without updating this manual.

Electronic version of this manual is available at:
www.cosmoappliances.com