

ASSEMBLY INSTRUCTIONS

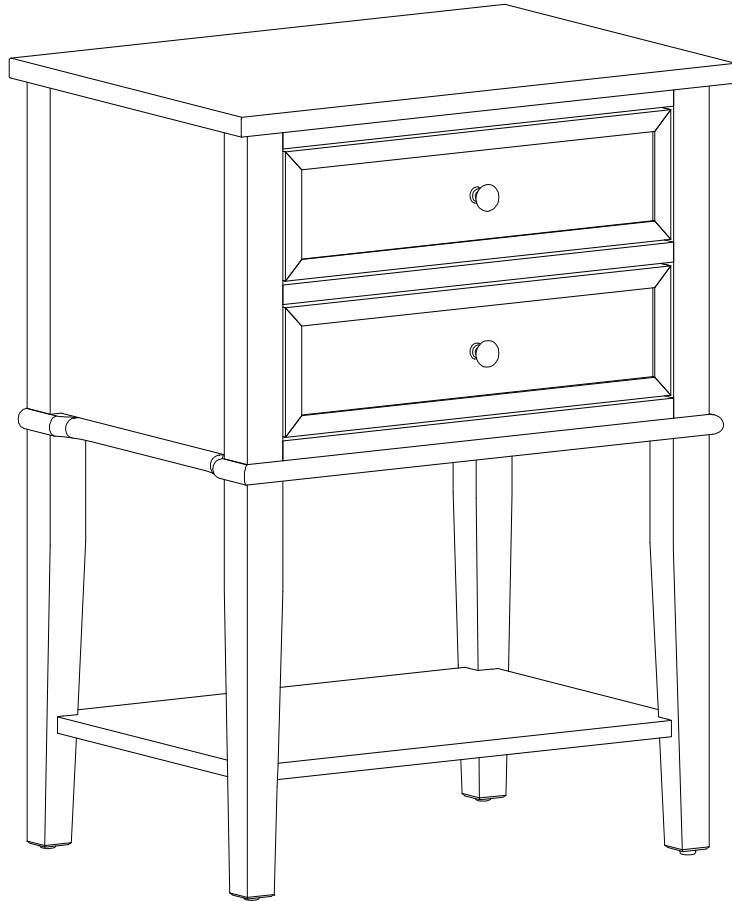

Product Dimension : 22"x15.7"x28"

Cube Size : 24"x17.7"x16.3"

NW: 33 LBS
GW: 37.4 LBS

BEFORE ASSEMBLY

Thank you for purchasing our product. This product has been designed for easy assembly and long lasting use. Please take the time to read and follow the assembly instructions carefully.

Be sure to check all packing material carefully for small parts that may have come loose inside the carton during shipment. Please separate, identify, and count all parts and metal hardware. Compare with the part list to be sure all parts are present. If the hardware is missing or you have difficulty assembling this product, please call for us.

IMPORTANT NOTE:

- Place all wooden parts on a clean and smooth surface such as a rug or carpet to avoid the parts from being scratched.
- Remove all wrapping material, including staples & packing straps, before you start to assemble.
- DO NOT tighten all screws and bolts until completely assembled.
- Keep all hardware parts out of reach of children.



PART LIST

When unpacking, please be careful not to discard any parts with the packaging. Before continuing, please make sure you have the following parts:

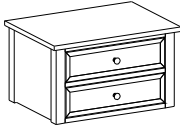
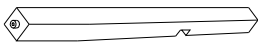
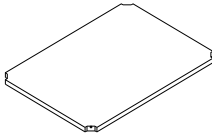
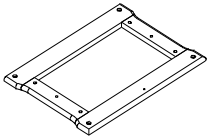
NO	Description	Qty	Sketch	NO	Description	Qty	Sketch
A	Chest	1		B	Legs	4	
C	Middle Shelf	1		D	Bottom Frame	1	

HARDWARE LIST

When unpacking, please be careful not to discard any parts with the packaging. Before continuing, please make sure you have all of the following hardware:

NO	Description	Qty	Sketch	NO	Description	Qty	Sketch
1	Bolt (M6x30mm)	4		2	Bolt Screw (M6x40mm)	4	
3	Screw (M4x35mm)	4		4	Screw (M4x25mm)	1	
5	Lock washer (Ø6.5mx9mm)	4		6	Plat washer (Ø6.5mx19mm)	4	
7	Allen key	1					

STEP 1

Attach two Legs (B) to the Bottom frame (D) with Bolt screws (2) then Tighten with Allen key (7).

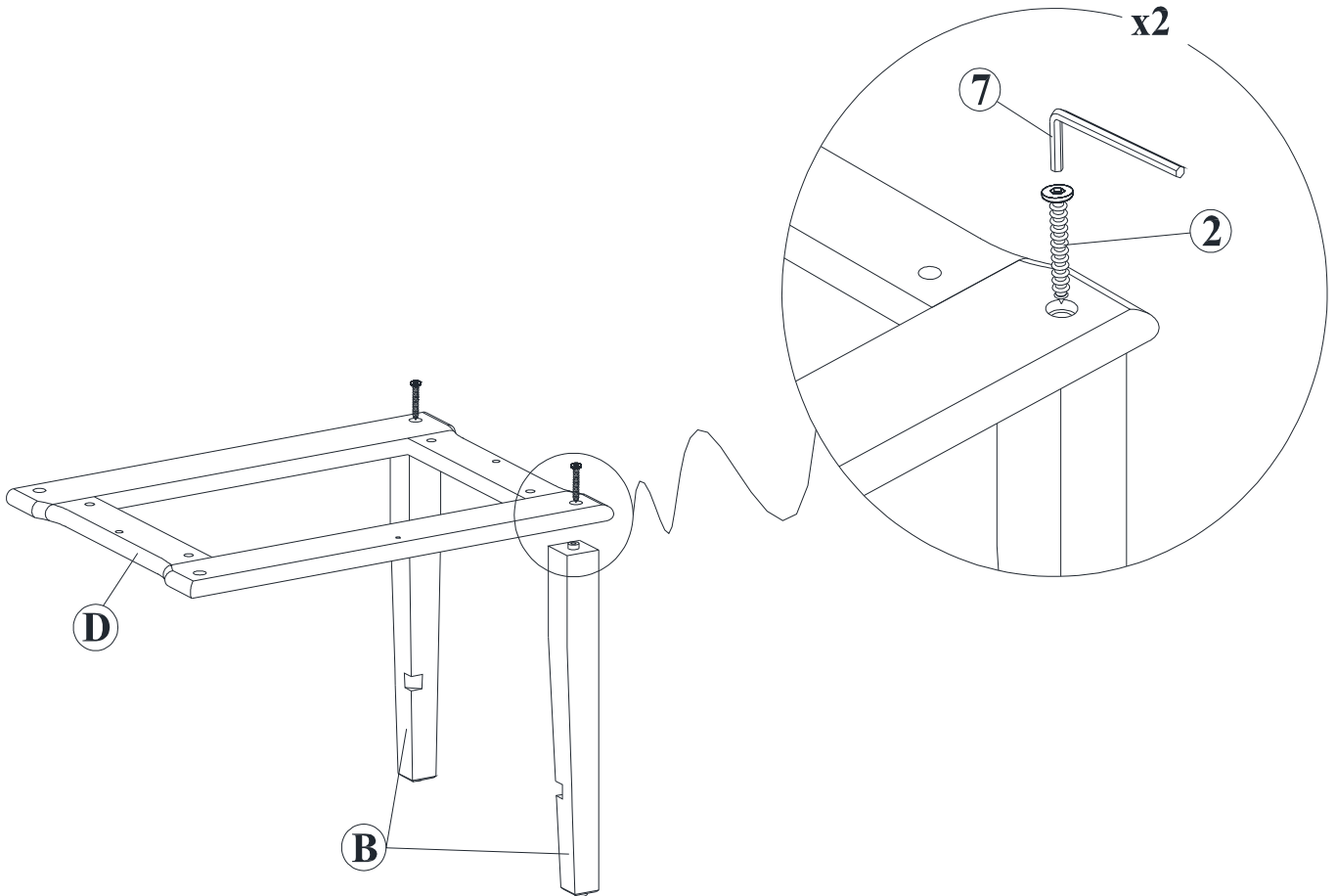

STEP 2

Attach shelf (C) to the legs (B) (on step 1) and attach both the other legs to the bottom frame (D) with bolt screws (2) tighten with the Allen Key (7). Use the screw driver to tighten the screws (3) as shown below.

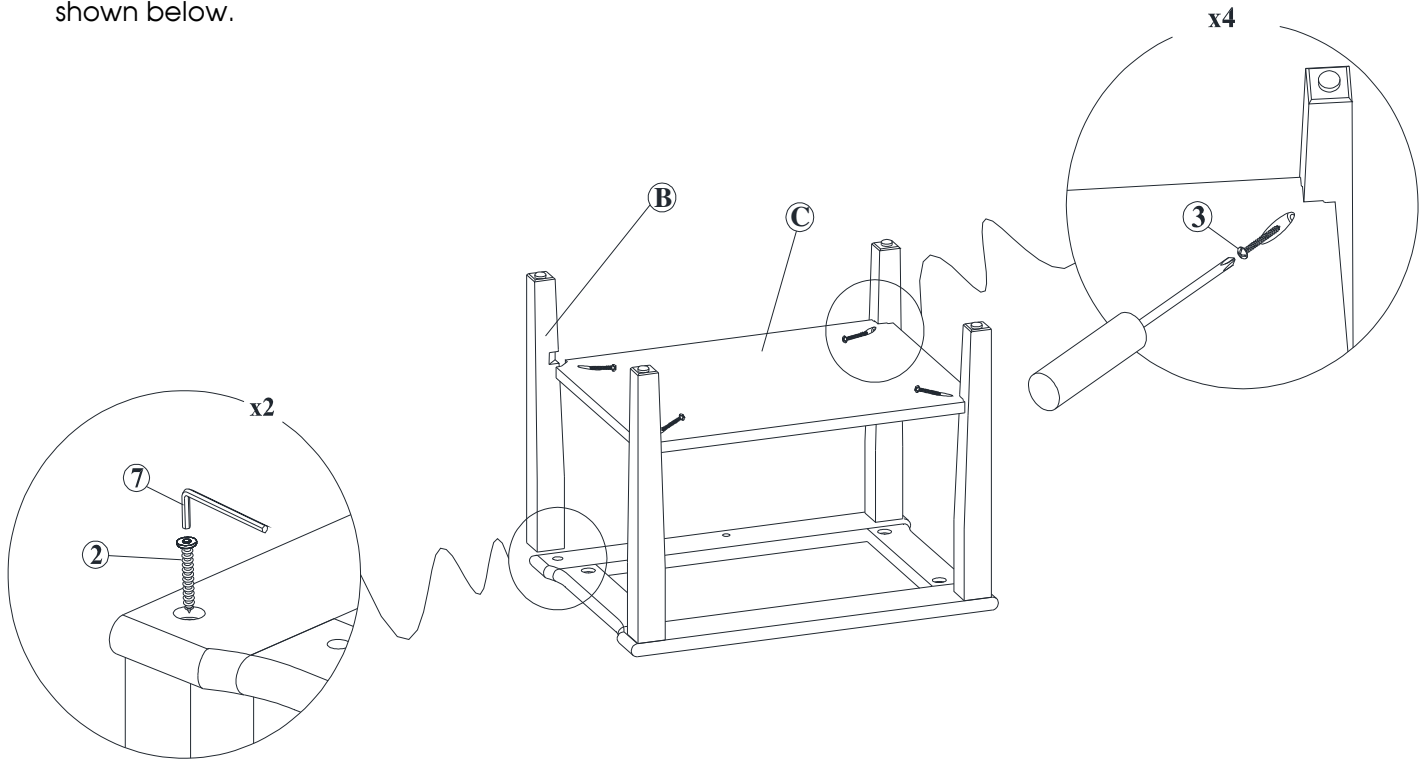

STEP 3

Slowly pull out Drawers of Chest (A) out as shown below.

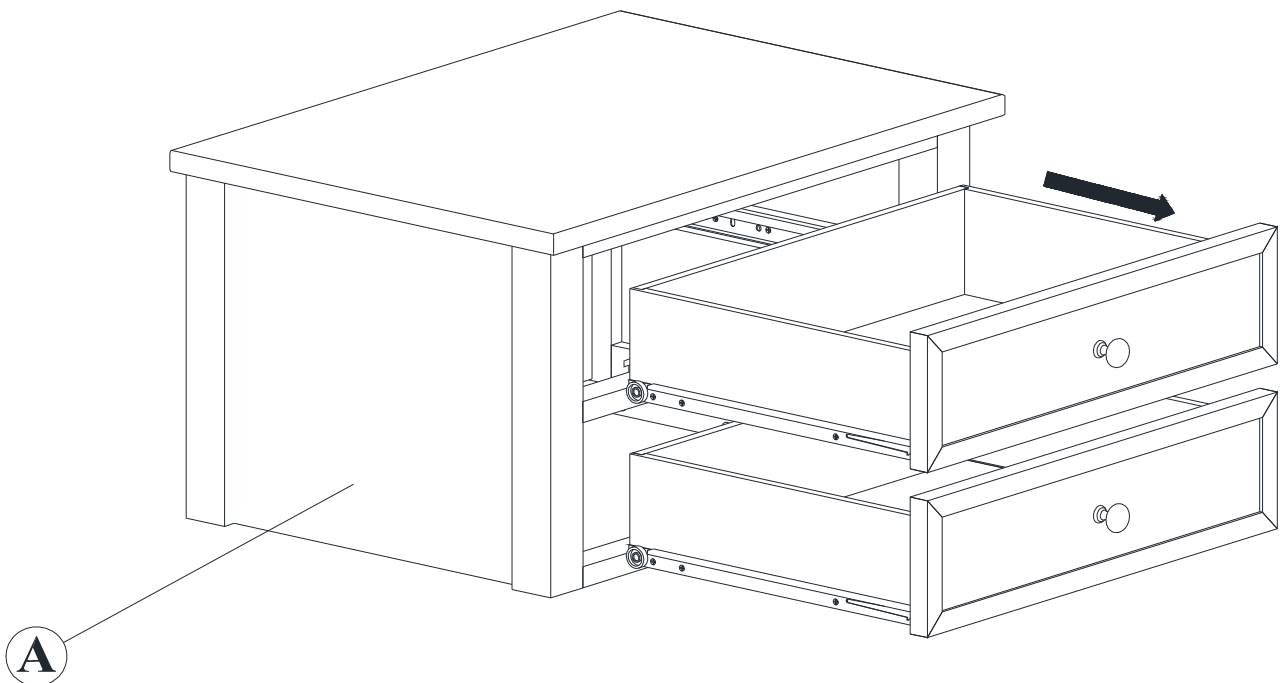

STEP 4

Attach the bottom of the chest (completed in step 2) to the Chest (Step 3) with bolts (1) and washers (5), (6) . Tighten with Allen key (7). Use the screw driver to tighten the screws (4) as shown below.

