

LOUNGE CHAIR

Assembly Instructions

3"
BUTTON
BOLTS



2 1/4"
BUTTON
BOLTS



FLANGE
NUTS



FLAT
WASHERS



TOOLS NEEDED

- 1/2" open end wrench
- 3/16" Allen wrench

PARTS LIST

- 1 – assembled back
- 1 – assembled seat
- 2 – assembled arms
- 8 – 2 1/4" button bolts
- 4 – 3" button bolts
- 4 – flat washers
- 12 – flange nuts

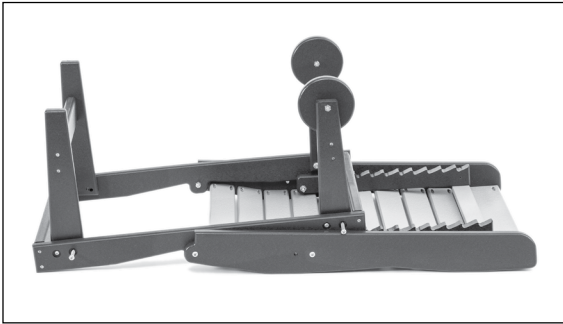

FIGURE 1

Lay chair back and base on floor as shown. Place legs in upright position.

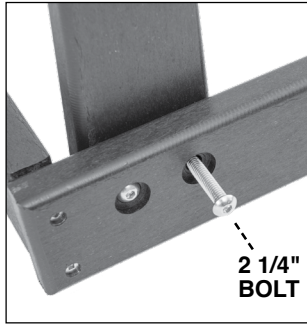

FIGURE 2

Align predrilled holes and insert 2 1/4" bolts.

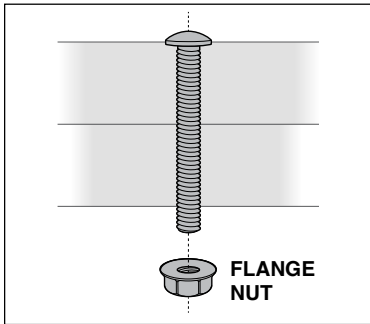

FIGURE 2-1

Add flange nuts to inside of frame. Tighten thoroughly.

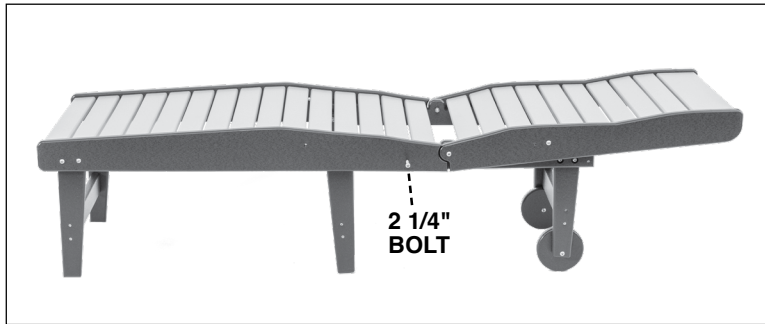

FIGURE 3

Flip base and back over (legs down). Set seat piece on base as shown. Align predrilled holes and insert 2 1/4" bolts. Add flange nuts to inside of frame. Tighten thoroughly.

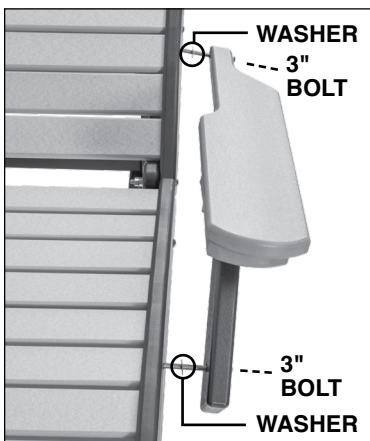

FIGURE 4

Attach arms. Put washer between arm and frame. Insert 3" bolts. Put on flange nut. Tighten thoroughly.

