

Assembly Instructions

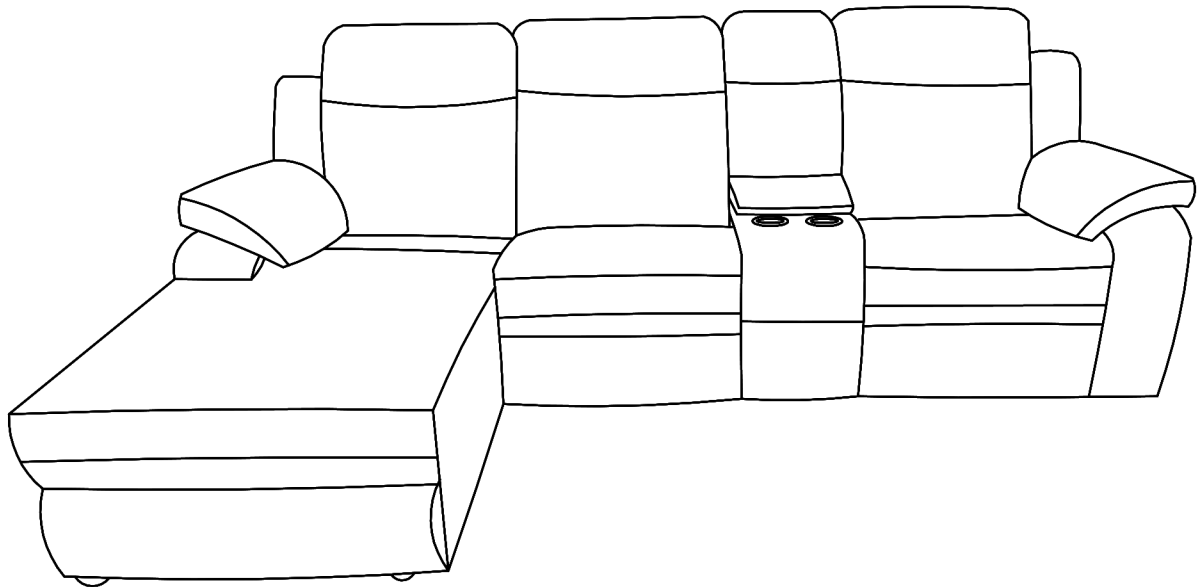

ASSEMBLY RATING

The Assembly Rating is a 5-point system that shows the degree of effort needed in assembling a specific product (with 1 being easy and 5 being difficult). For some products, two persons are recommended.

No Tools Required For Assembly

EASY  DIFFICULT



2 PERSONS RECOMMENDED

ASSEMBLY & CARE ADVICE

FOR YOUR FURNITURE TO LAST, CORRECT ASSEMBLY AND PROPER MAINTENANCE ARE NECESSARY. PLEASE FOLLOW THE INFORMATION PROVIDED BELOW TO FULLY ENJOY YOUR FURNITURE.

BASIC ASSEMBLY TECHNIQUES

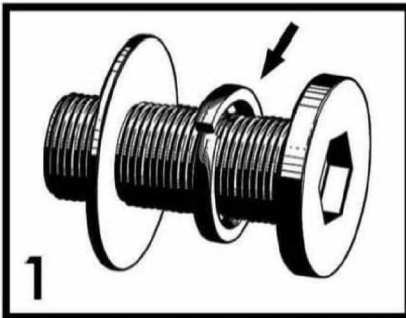

When lock or spring washer is used in an assembly, please make sure the lock or spring washer is placed between the larger flat washer and the head of the screw or bolt.

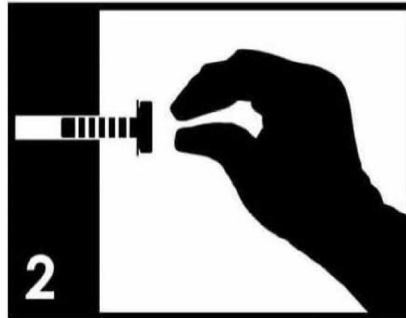

Position each part correctly and insert screws or bolts into their respective holes by hand tighten or using the proper hand tool. Only tighten when step is completed or when instructed to do so.

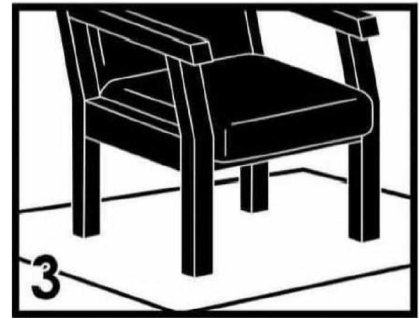

Use cardboard or carpet area when assembling furniture to prevent scratches. Make sure the furniture rests on a flat and level surface with each leg evenly touching the floor.

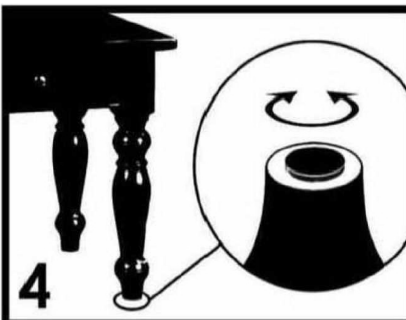

Some furniture comes with height adjustment knobs underneath each leg. To lower or to raise each leg, you need to turn clockwise or counterclockwise, respectively.

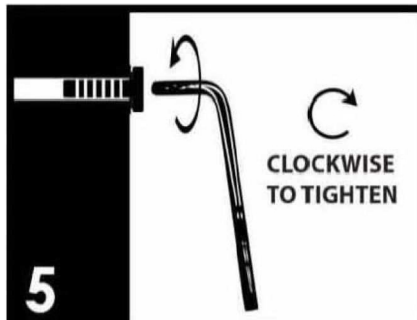

Make sure all parts are properly aligned, then use the appropriate hand tool to completely tighten the bolts or screws. Do not use power tools and do not overtighten.

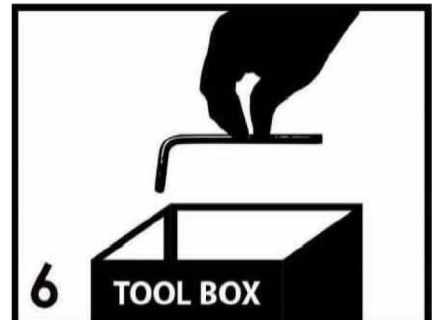

Save the instructions and store the Allen wrench or any supplied tool for later maintenance. After two weeks, check and tighten any loose hardware and repeat again every six months thereafter.

IT IS THE USER'S RESPONSIBILITY TO MAINTAIN THE FURNITURE. THE HARDWARE MAY LOOSEN OVER TIME AND MAY CAUSE THE FURNITURE TO BE WOBBLY AND UNABLE TO SUPPORT ITS INTENDED WEIGHT CAPACITY. THIS MAY LEAD TO COLLAPSE AND MAY CAUSE SERIOUS INJURY.



FAILURE TO FOLLOW THE GUIDELINES ABOVE MAY RESULT IN INJURY AND/OR PROPERTY DAMAGE.

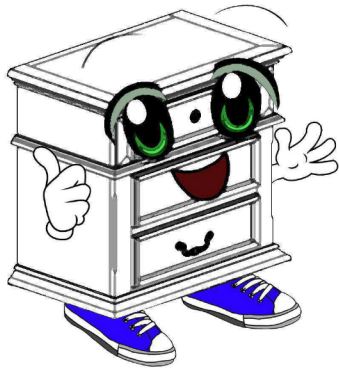

Before you begin, please read Page 2 of "Assembly and Care Advice".

And remember, do not tighten until each step is completed or instructed.

Parts List



#1 x 2pcs
Loveseat Back Cushion



#2 x 1pc
Royal Chair Back Cushion



#3 x 1pc
Console Back Cushion



#4 x 1pc
Left ear



#5 x 1pc
Right ear

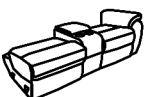

#6 x 1pc
Loveseat



#7 x 1pc
Royal Chair



#8 x 4pcs
Leg



#9 x 1pc
Support Leg



Align the brackets along the love seat back cushion (#1) to the brackets along the love seat (#6). Slide until firmly secured.

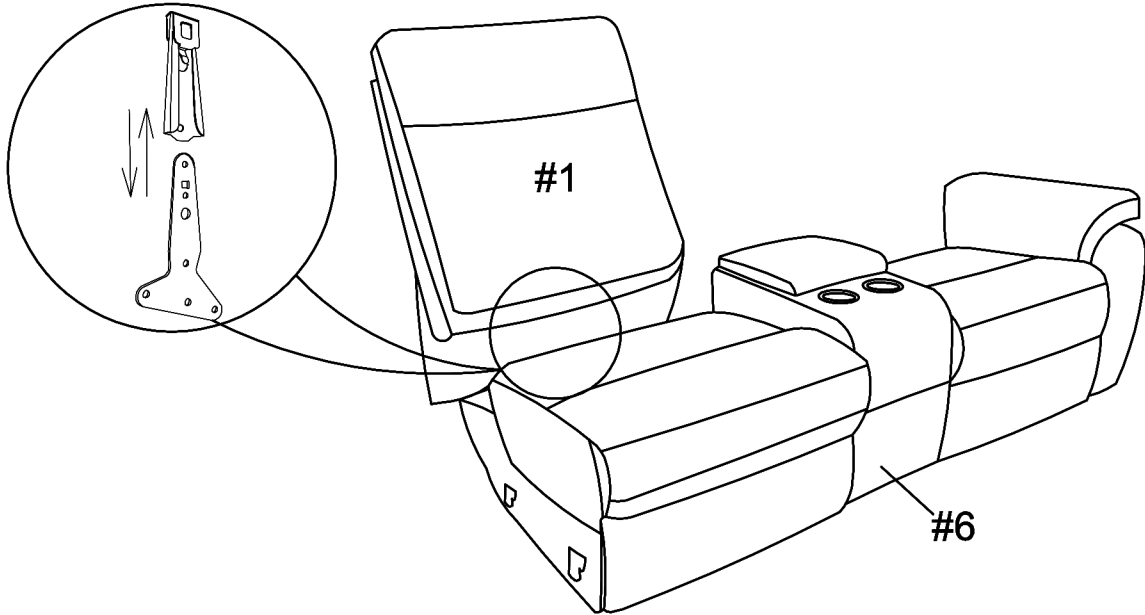

Align the brackets along the console back cushion (#3) to the brackets along the love seat (#6). Slide until firmly secured.

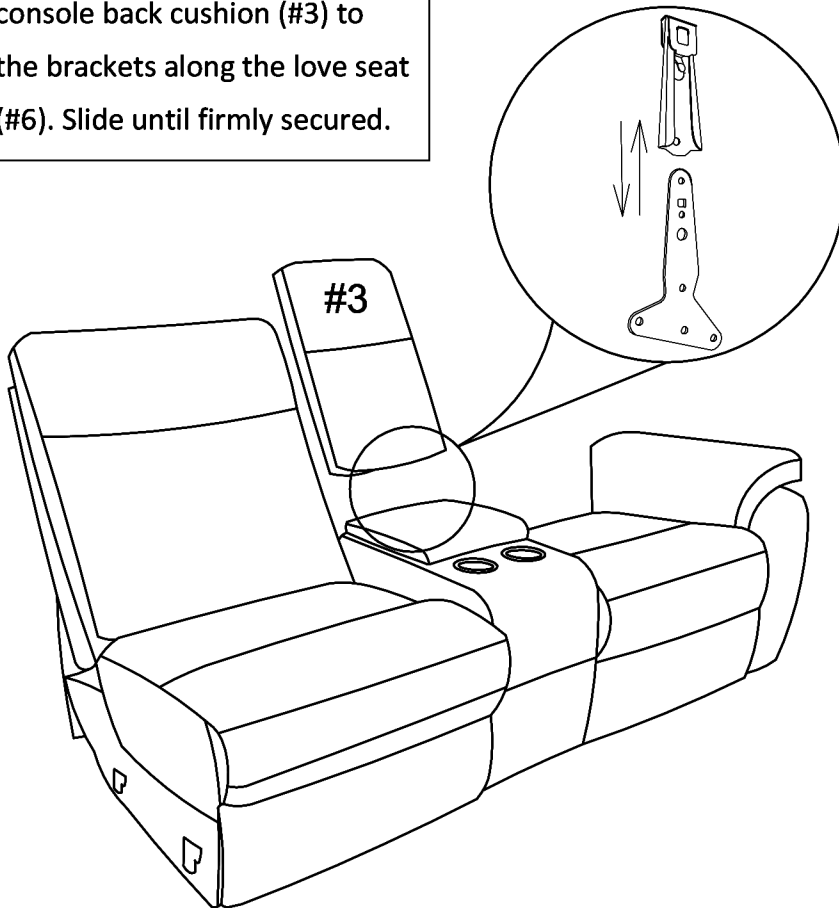



Align the brackets along the love seat back cushion (#1) to the brackets along the love seat (#6). Slide until firmly secured.

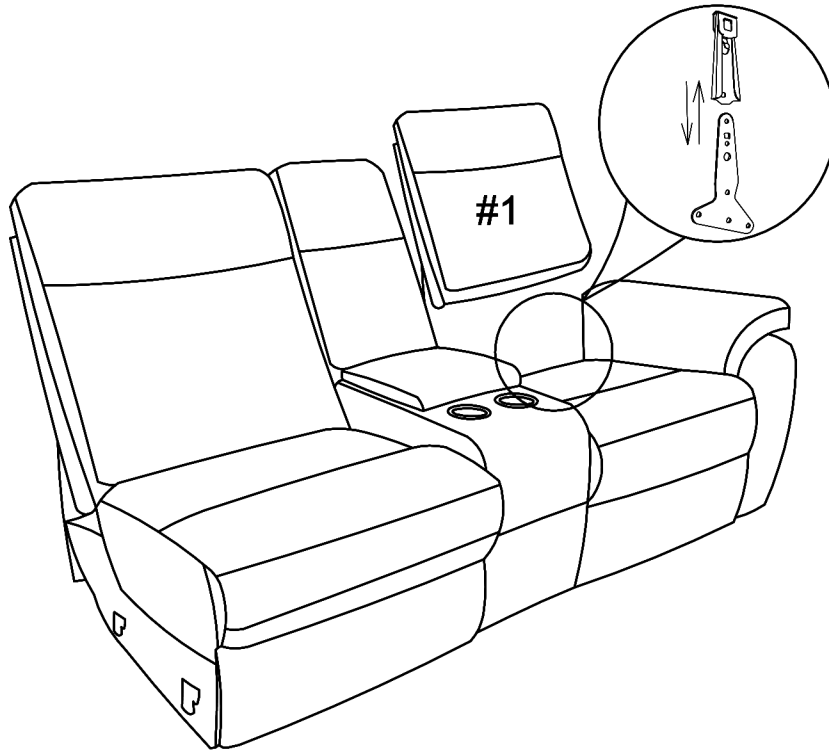

Align the brackets along the right ear (#4) to the brackets along the right side of the love seat (#6). Slide until firmly secured.

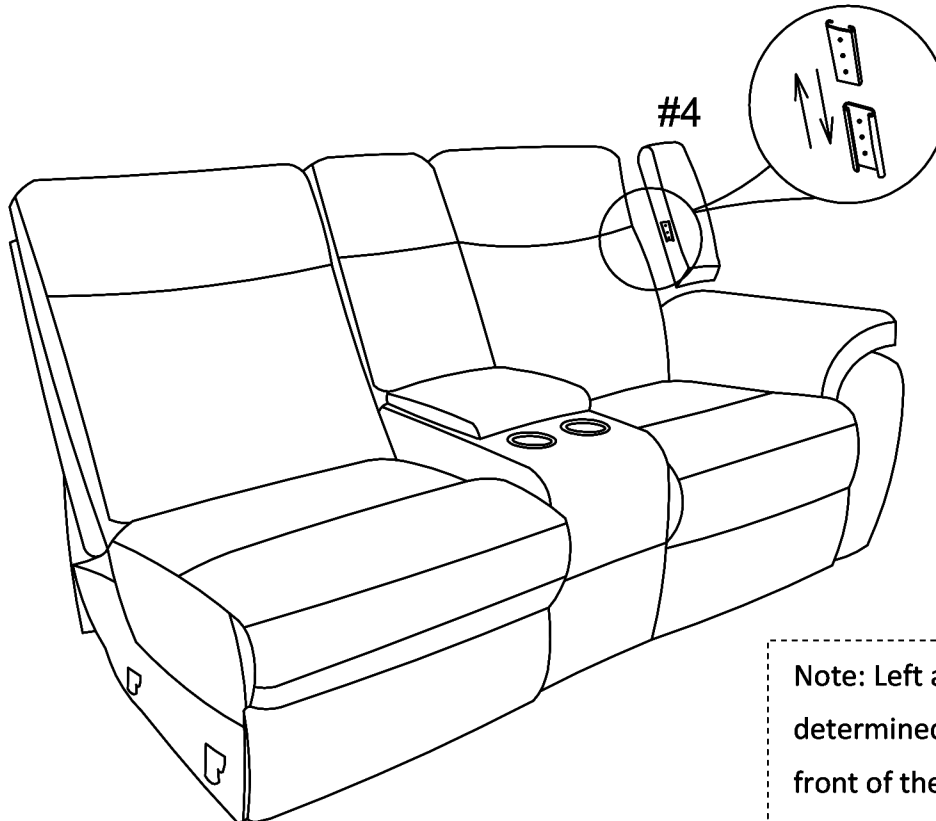

Note: Left and right are determined by facing the front of the love seat in its upright position.

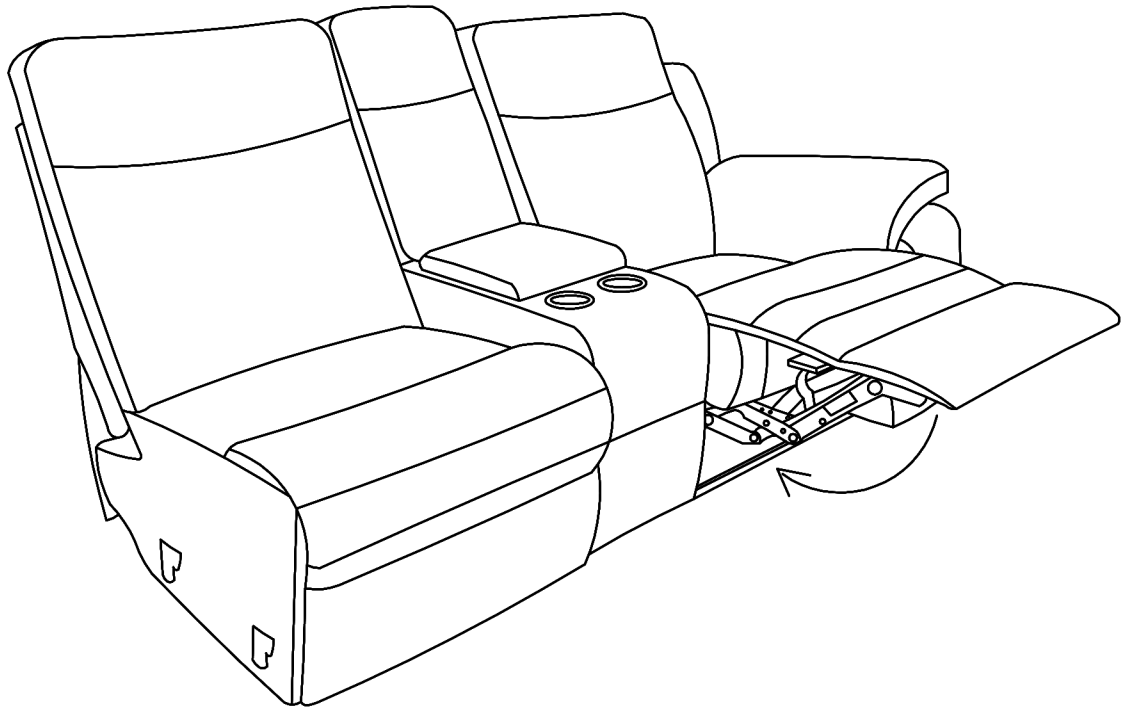

Insert the threaded ends of the legs (#8) into the bottom corner holes along the bottom of the royal chair (#7). Turn right to tighten.

Insert the threaded end of the support leg (#9) into the center hole, turn right to tighten.

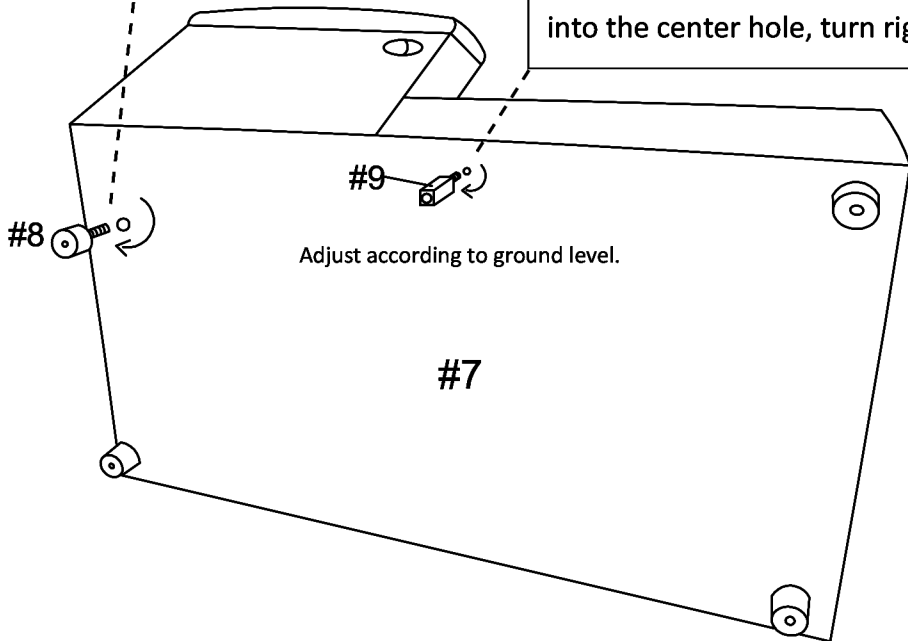



Align the brackets along the royal chair back cushion (#2) to the brackets along the royal chair (#7). Slide until firmly secured.

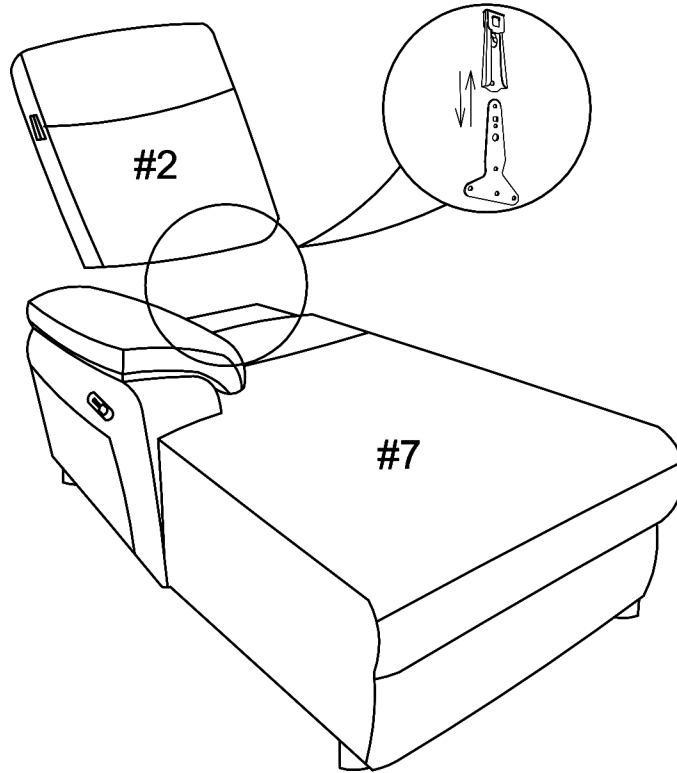

Align the brackets along the right ear (#5) to the brackets along the royal chair (#7). Slide until firmly secured.

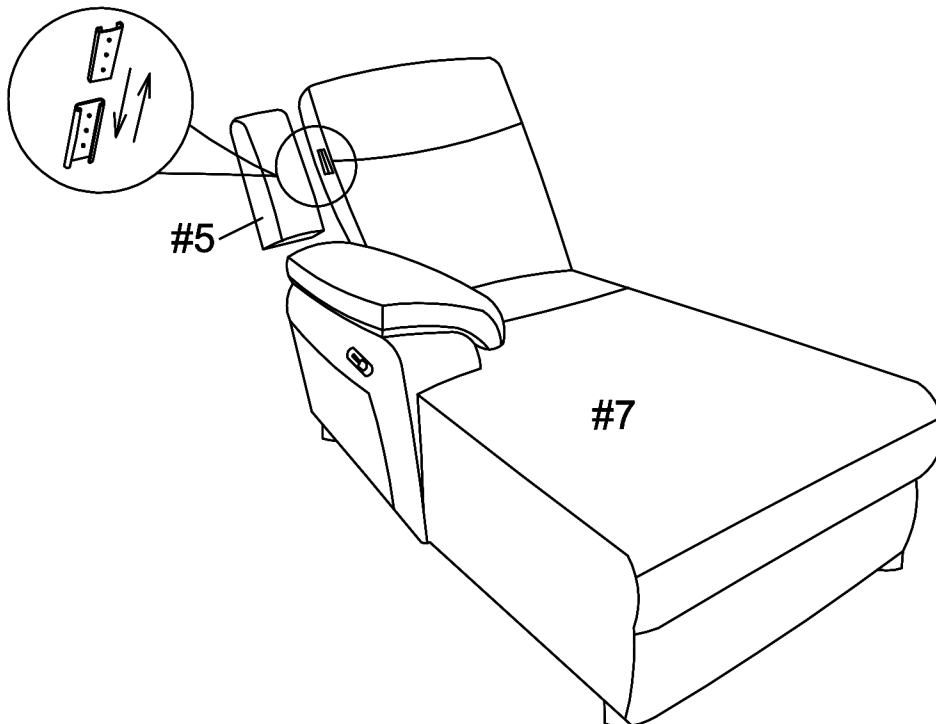

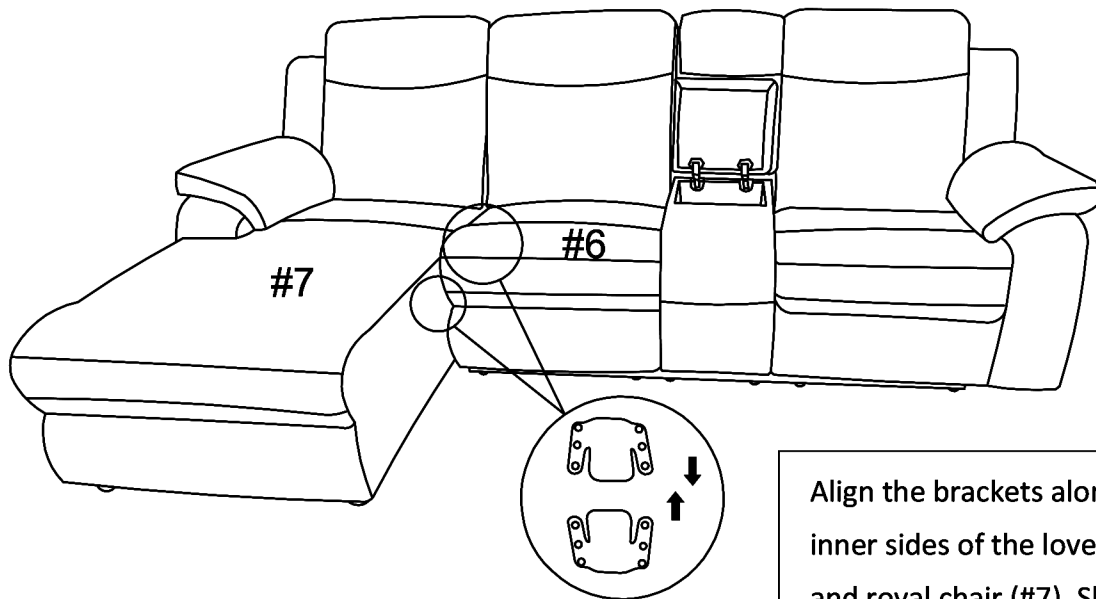
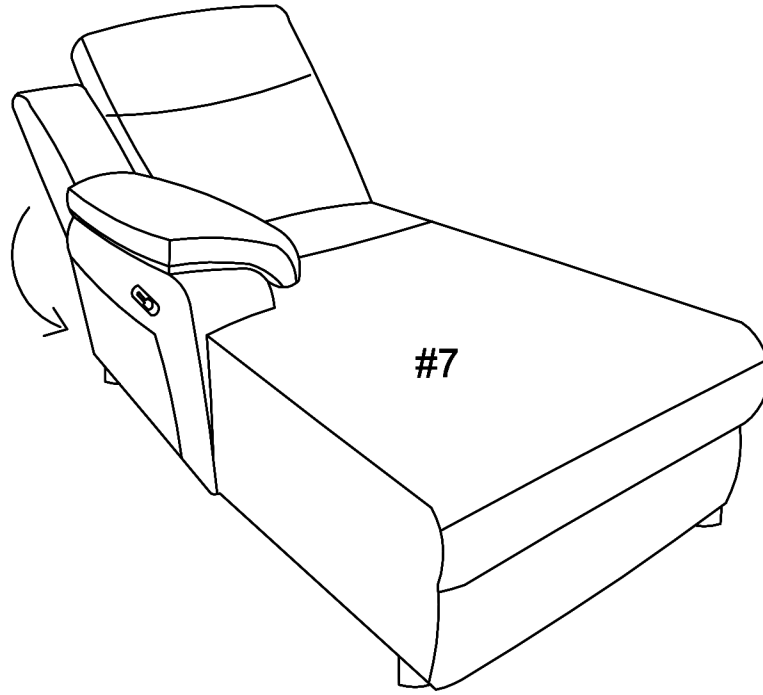

Align the brackets along the inner sides of the loves seat (#6) and royal chair (#7). Slide the brackets until firmly secured.

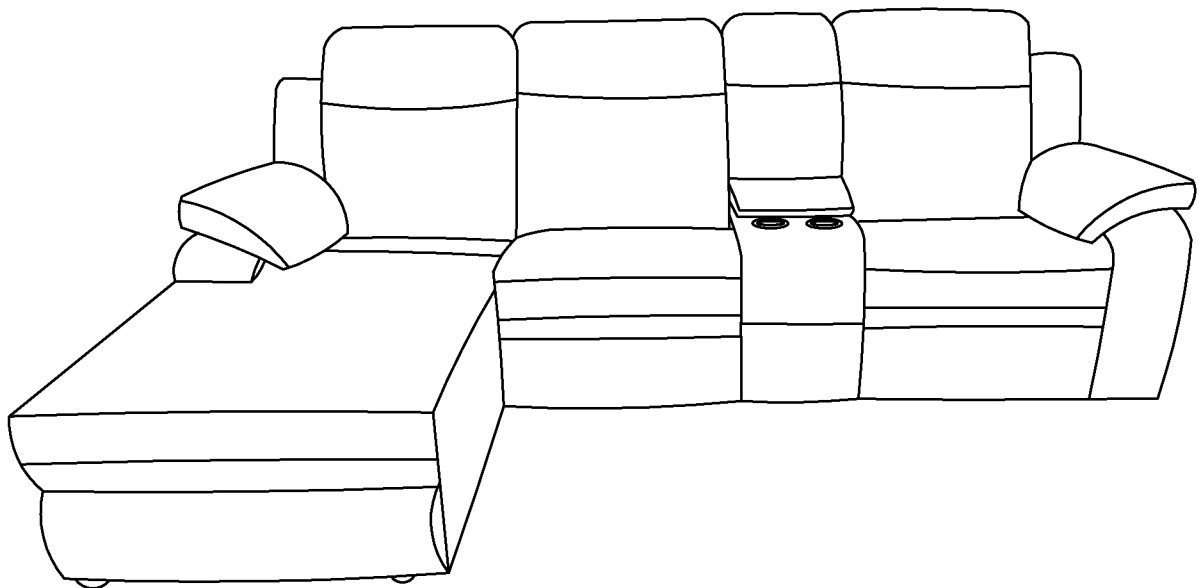
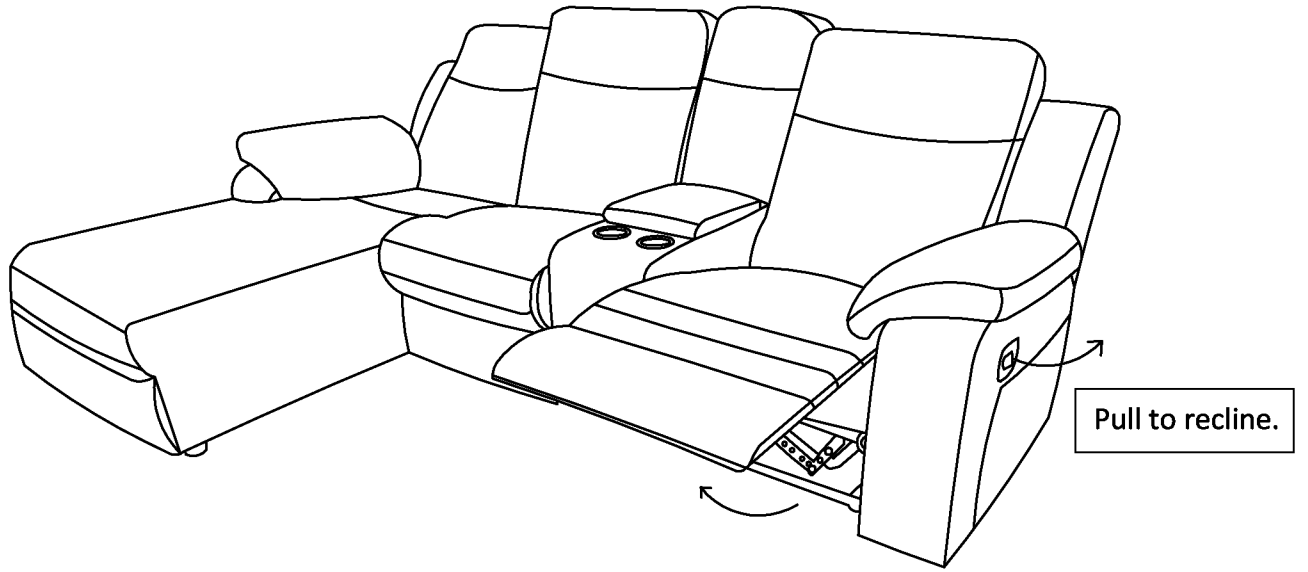

ASSEMBLY IS COMPLETED