

ASSEMBLY GUIDE

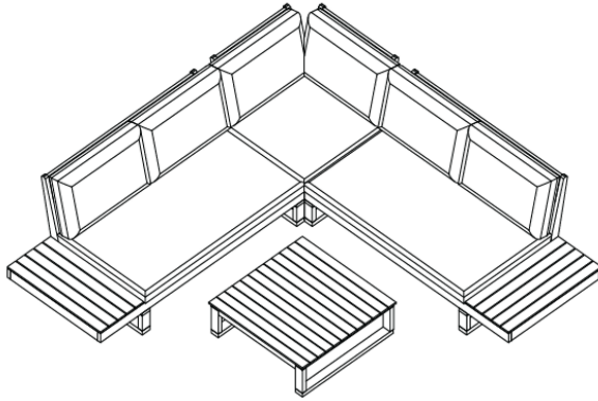

Important - Please read these instructions fully before starting assembly



**SAFETY AND
CARE ADVICE**



NO POWER TOOLS

SAFETY AND CARE ADVICE

- Check you have all the components and tools listed.
- Remove all fittings from the plastic bags and separate them into their groups.
- We do not recommend the use of power drills/drivers for inserting screws, as this could damage the unit. Only use hand screwdrivers and Allen keys.
- Keep children and animals away from the work area, small parts could cause choking if swallowed.
- Make sure you have enough space to lay out the parts before starting.
- Assemble the item as close to its final position as possible.
- Do not overtighten the nuts to avoid causing damage to the threads.
- Only clean using a damp cloth and mild detergent, do not use bleach or abrasive cleaners.
- From time to time check that there are no loose screws on this unit
- This product should not be discarded with household waste. Take to your local authority waste disposal centre

IMPORTANT INFORMATION



30 MINUTE
BUILD







TWO
PERSON





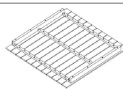





TABLE MAX CAPACITY 75Kg
SOFA MAX CAPACITY 110Kg
CHAIR MAX CAPACITY 110Kg

PLEASE CHECK CAREFULLY AND MAKE SURE YOU HAVE ALL FITTINGS AND TOOLS LISTED BELOW BEFORE YOU START.









Table Parts

PARTS		
CODE	PICTURES	Q.TY
A	 Table Top	1pc
B	 Leg	2pcs
HARDWARES		
CODE	PICTURES	Q.TY
1	 Bolt M8x40x15	6pcs
2	 Allen Key M4	1pc







Left Bench Parts

PARTS			PARTS		
CODE	PICTURES	Q.TY	CODE	PICTURES	Q.TY
F	 Seat	1pc	D	 Seat Cushion (Bench 2)	1pc
B	 Back	1pc	E	 Back Cushion	2pcs
C	 Leg	2pcs	HARDWARES		
			CODE	PICTURES	Q.TY
			1	 Bolt M8x45x15	6pcs
			2	 Bolt M8x55x15	6pcs
			3	 Allen Key M4	1pc

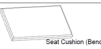
Corner Bench Parts

PARTS			PARTS		
CODE	PICTURES	Q.TY	CODE	PICTURES	Q.TY
A	 Seat	1pc	D	 Seat Cushion (Bench Corner)	1pc
B	 Back	2pcs	E	 Back Cushion	2pcs
C	 Leg	2pcs	HARDWARES		
			CODE	PICTURES	Q.TY
			1	 Bolt M8x45x15	6pcs
			2	 Bolt M8x55x15	6pcs
			3	 Allen Key M4	1pc

Right Bench Parts

PARTS			PARTS		
CODE	PICTURES	Q.TY	CODE	PICTURES	Q.TY
A	 Seat	1pc	D	 Seat Cushion (Bench 2)	1pc
B	 Back	1pc	E	 Back Cushion	2pcs
C	 Leg	2pcs	HARDWARES		
			CODE	PICTURES	Q.TY
			1	 Bolt M8x45x15	6pcs
			2	 Bolt M8x55x15	6pcs
			3	 Allen Key M4	1pc

NOTE: The quantities above are the correct amount to complete the assembly. In some cases more fittings may be supplied than are required.

Table Assembly

STEP 1

Use a clear, flat, soft surface to avoid bumps or scratches. Lay all your components and fixings out.

Place the table top [A] upside down and align 2 x legs [B]. Attach using 6 x bolts [1] and tighten with allen key [2].

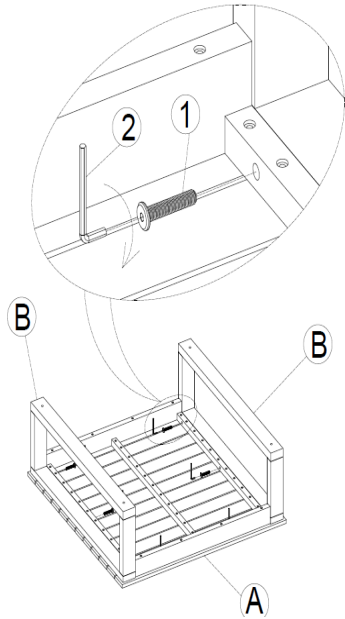

STEP 2

Carefully, and with help, flip your table so it stands on its legs. Check stability. Your table is now ready to use!

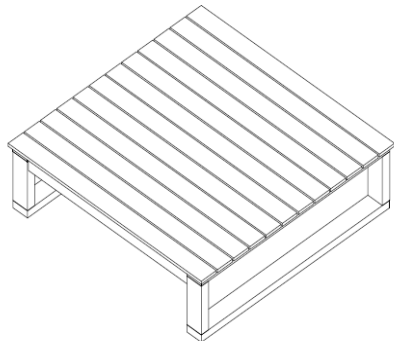

Left Bench Assembly

STEP 3

Place back rest panel [B] on the flat surface and align the left bench seat panel [F] onto the pre-drilled holes. Attach using 2 x bolts [2] and tighten with allen key [3] - 6 bolts in total.

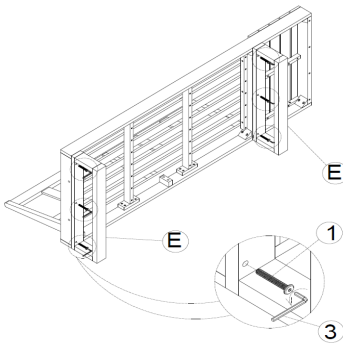
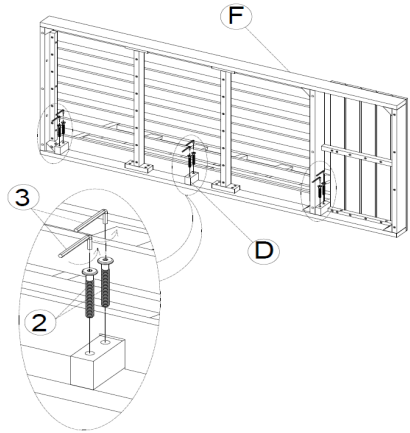

STEP 4

Align 2 x legs [E] to the pre-drilled holes on the seat panel [F] and secure using 3 x bolts [1] - 6 in total. Tighten with allen key [3].

STEP 5

Carefully, and with help, flip the bench onto the legs. Check stability.

Place 1 x seat cushion [D] + 2 x back rest cushion [E] into place.

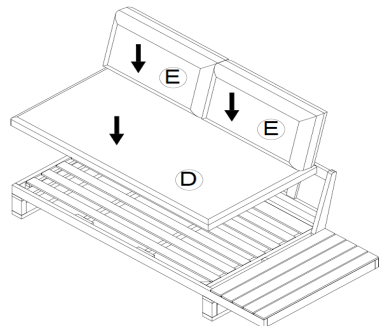

Right Bench Assembly

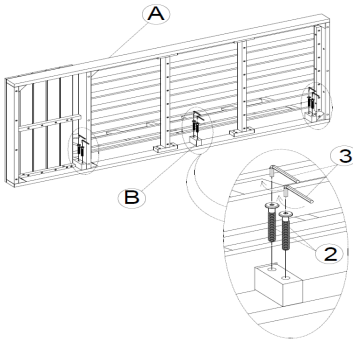

STEP 6

Place back rest panel [B] on the flat surface and align the right bench seat panel [A] onto the pre-drilled holes.

Attach using 2 x bolts [2] and tighten with allen key [3] - 6 in total.

STEP 7

Align 2 x legs [C] to the pre-drilled holes on the seat panel [A] and secure using 3 x bolts [1] - 6 in total.

Tighten with allen key [3].

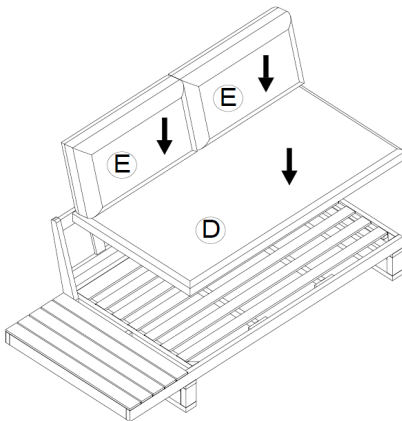
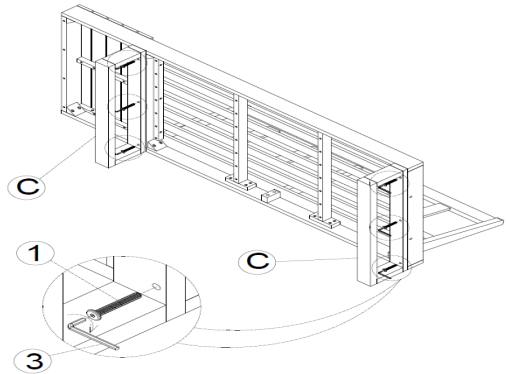

STEP 8

Carefully, and with help, flip the bench onto the legs. Check stability.

Place 1 x seat cushion [D] + 2 x back rest cushion [E] into place.

Corner Bench Assembly

STEP 9

Place 1 x back rest panels [B] on the flat surface and align the second back rest panel [B] plus the corner bench seat panel [A] onto the pre-drilled holes. Attach using 2 x bolts [2] and tighten with allen key [3] - 8 in total.

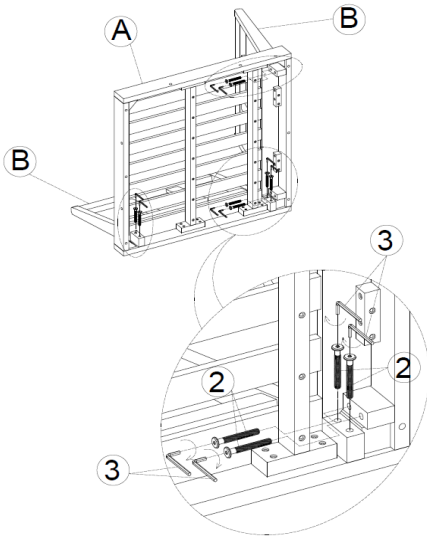

STEP 10

Align 2 x legs [C] to the pre-drilled holes on the seat panel [A] and secure using 3 x bolts [1] - 6 in total. Tighten with allen key [3].

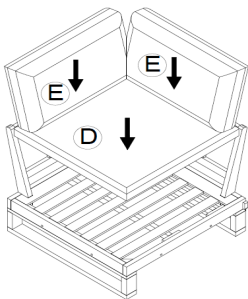
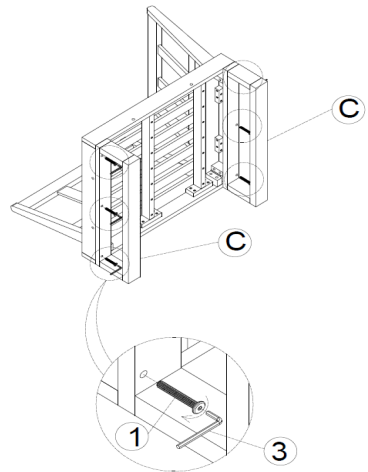

STEP 11

Carefully, and with help, flip the corner bench onto the legs. Check stability.

Place 1 x seat cushion [D] + 2 x back rest cushion [E] into place.

Full Bench Assembly

STEP 12

Align the assembled left and right benches [A + B] with the pre-drilled holes on the assembled corner bench [C]. Attach using 4 x bolts [1] and tighten with allen key [2].

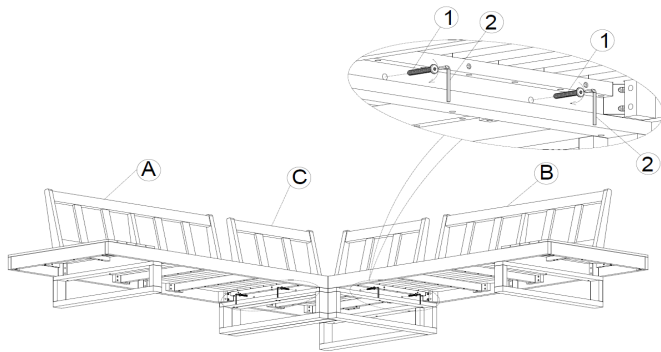

STEP 13

Carefully, and with help, flip the full bench onto the legs. Check stability.

Place 3 x seat cushions [D + E] + 6 x back rest cushions [F] into place.

Your full bench seat is now ready to use!

