

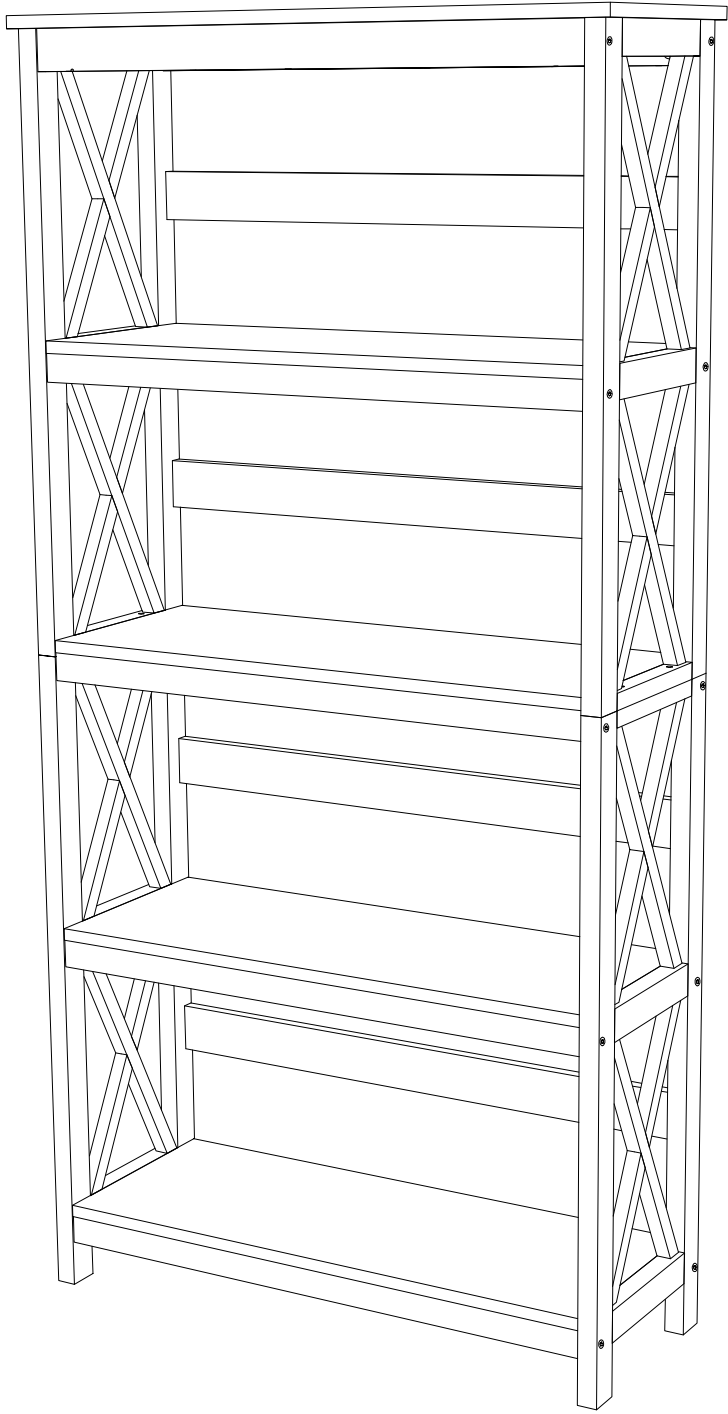

**ASSEMBLY INSTRUCTIONS / INSTRUCTIONS
D'ASSEMBLAGE / INSTRUCTIVO DE ARMADO**



FG-DI/KO/DJ-PU-3-251-WAY

NOTES ON ASSEMBLY / NOTES POUR L'ASSEMBLAGE / NOTAS SOBRE EL ENSAMBLE

- To ensure ease of assembly read all instructions before assembly and follow step by step illustrations.
- Keep instructions for future use.
- Adult assembly required. 
- Due to the presence of small parts during assembly, keep out of reach of children until assembly is complete.

- Pour assurer l'assemblage facile veuillez lire toutes les instructions avant l'assemblage et veuillez suivre les illustrations pour chaque étapes.
- Veuillez garder ces instructions pour l'usage ulterieur.
- Assemblage requis pas un adulte. 
- Due a la presence de petite pieces durant l'assemblage, veuillez garder hors de porter des enfants jusqu'a ce que l'assemblage soit completer.

- Para garantizar la facilidad de ensamble lea las instrucciones antes de iniciar y siga paso a paso las ilustraciones.
- Guarde las instrucciones para futuras referencias.
- El ensamble requiere de un adulto. 
- Debido a que hay piezas pequeñas, mantenga fuera del alcance a los niños durante el ensamble, hasta que haya terminado.

MAINTENANCE TIPS / CONSEILS D'ENTRETIEN / CONSEJOS DE MANUTENIMIENTO

- Never let liquids or damp cloths sit on this furniture.
- Never use chemical cleaning products. They can damage the finish. For cleaning, use only a slightly damp cloth and wipe dry.
- To avoid dulling of the finish, do not place furniture in direct sunlight.
- Do not put plastic or rubber rings under appliances. Use cloth of felt protectors.
- To clean, use a soft or slightly damp cloth, then wipe with a clean, dry cloth.

- Ne jamais laisser de liquide ou linge humide sur le meuble.
- Ne jamais utiliser de nettoyeurs à base de produits chimiques, cela va endommager le fini. Utiliser seulement un linge légèrement humide.
- Ne pas placer le meuble directement au soleil pour prévenir le ternissement.
- Évitez de déposer des appareils avec des rondelles de plastique ou de caoutchouc. Utilisez un protecteur en tissu ou en feutre.
- Pour nettoyer, utilisez un linge doux ou légèrement humecté. Essuyez par la suite avec un linge propre et sec.

- Nunca deje un líquido o un trapo húmedo sobre el mueble.
- Nunca utilice limpiadores a base de químicos, estos dañaran le acabado. Use sólo un paño húmedo.
- No esponga el mueble directamente al sol para prevenir empañamiento.
- Evite apoyar aparatos con redondeles de plástico o de goma. Utilizar un protector de tela o de fieltro.
- Para limpiar, utilice un trapo suave o ligeramente humedecido. Seque luego con un trapo limpio y seco.

⚠ WARNING ⚠
AVERTISSEMENT / ADVERTENCIA

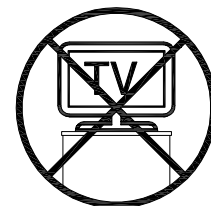
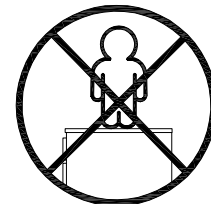
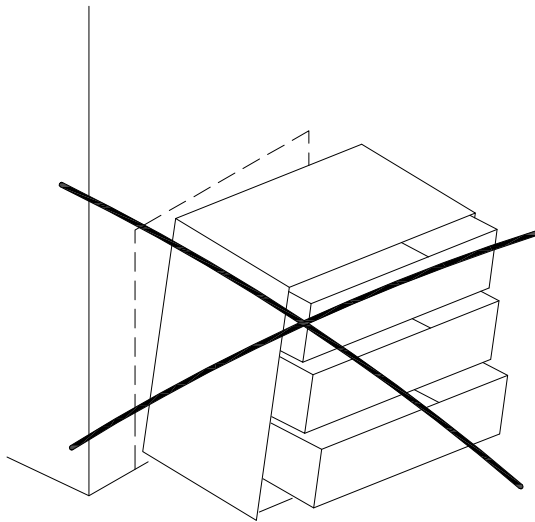
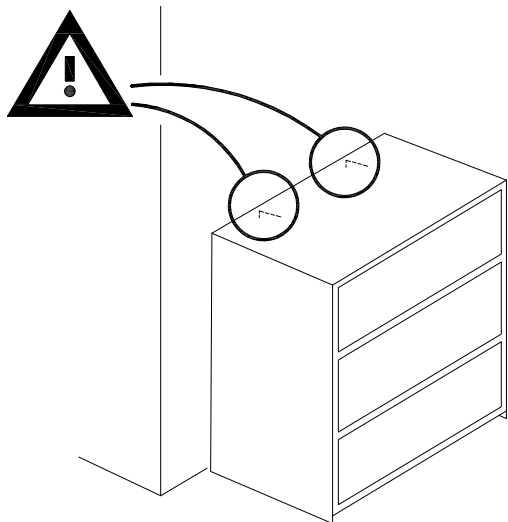

Children have died from furniture tipover. To reduce the risk of furniture tipover:

- ALWAYS install tipover restraint provided.
- NEVER put a TV on this product.
- NEVER allow children to stand, climb or hang on drawers, doors, or shelves.
- Never open more than one drawer at a time.
- Place heaviest items in the lowest drawers.

Enfants morts suite au basculement d'un meuble. Afin de limiter le risque de basculement de meuble :





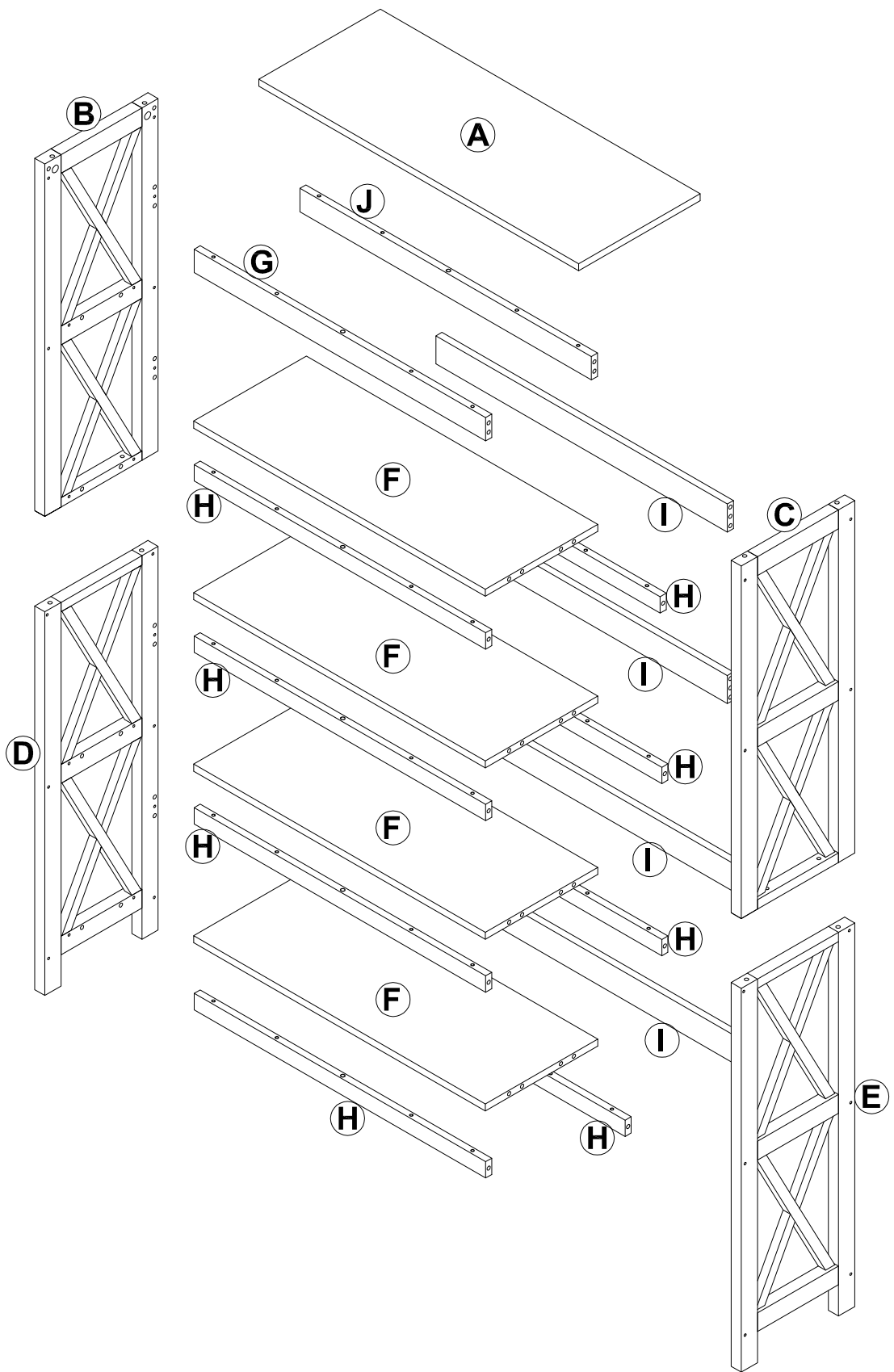

- TOUJOURS utiliser les fixations anti-basculement fournies.
- NE JAMAIS installer de TV sur ce produit.
- NE JAMAIS laisser d'enfants se tenir debout sur les tiroirs, portes ou étagères, y grimper ou s'y suspendre.
- NE JAMAIS ouvrir plus d'un tiroir à la fois.
- Placer les choses les plus lourdes dans les tiroirs du bas.

Han muerto niños por el vuelco de muebles. Para limitar el riesgo de vuelco de los muebles:



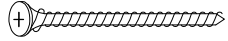

- Utilizar SIEMPRE las fijaciones antivuelco que se suministran.
- NUNCA instalar un TV sobre este producto.
- NUNCA permitir que los niños se pongan de pie, trepen o se cuelguen de los cajones, puertas o baldas.
- NUNCA abrir más de un cajón a la vez.
- Colocar los objetos más pesados en los cajones inferiores.

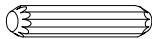

HARDWARE QUINCAILLERIE / HERRAJE

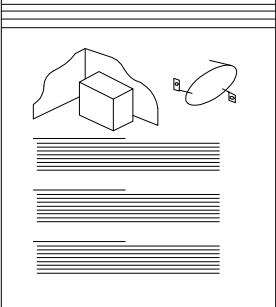
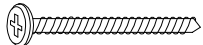
(A)	Cam Bolt	(B)	Cam Lock	(C)	Screw M4 x 38mm
					
	28 units		28 units		30 units
(D)	Dowel Ø8 x 30mm	(E)	Unitar M7 x 60mm	(F)	Hex Key M4
					
	56 units		20 units		1 units
(G)	Screw M6 x 25mm	(H)	Dowel Ø10 x 30mm		
					
	4 units		4 units		

FURNITURE TIPPING RESTRAINT SEGURO CONTRA VOLCADO DE MUEBLES DISPOSITIF DE SÉCURITÉ POUR MEUBLES

 x 2	(I)	Screw 2"	(J)	Screw 5/8"
				
		2 units		2 units
	(K)	Bracket	(L)	Restraint Strap
				
	4 units		2 units	

TOOLS NOT INCLUDED OUTILS PAS INCLUS / HERRAMIENTAS NO INCLUIDAS

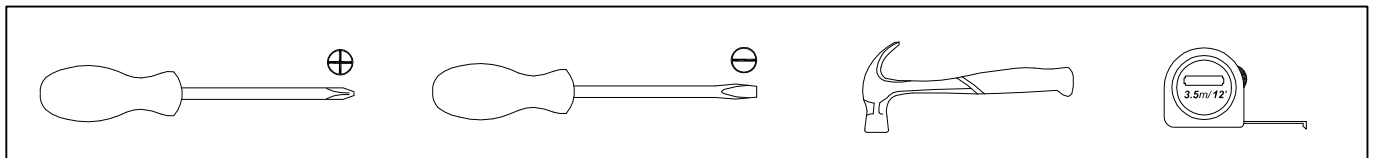

STEP 1

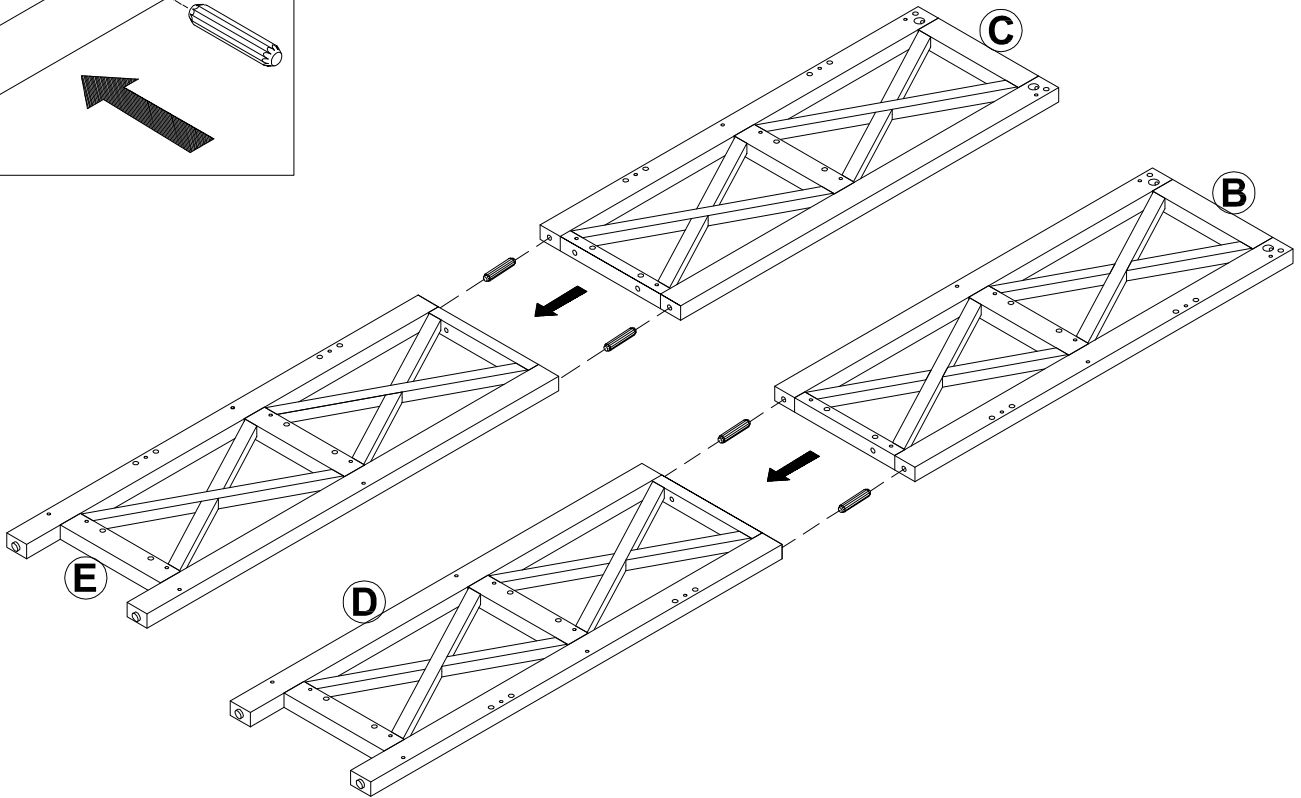
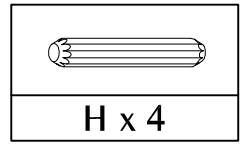
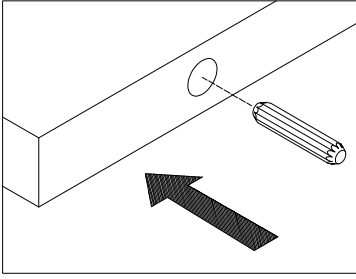

STEP 2

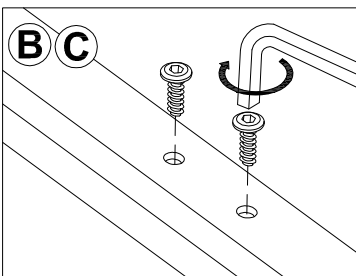
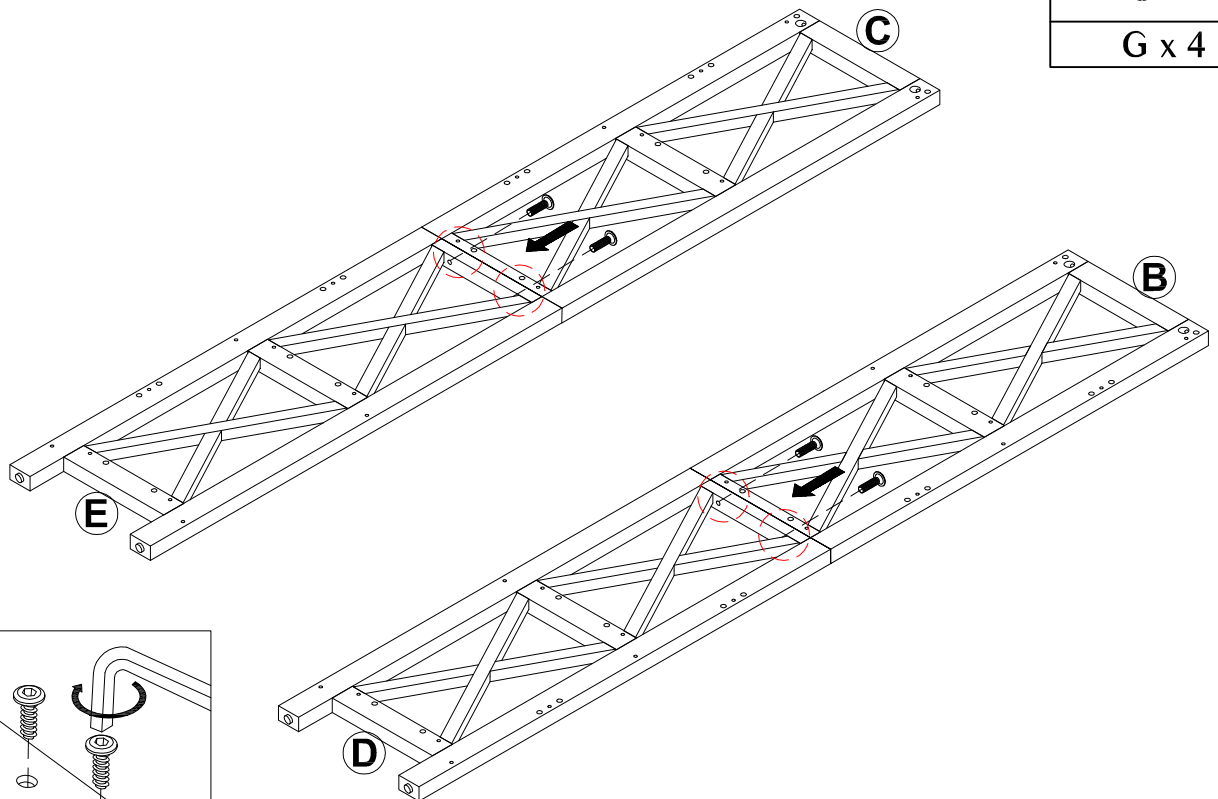
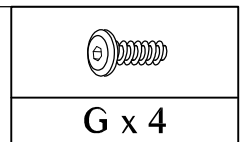

STEP 3

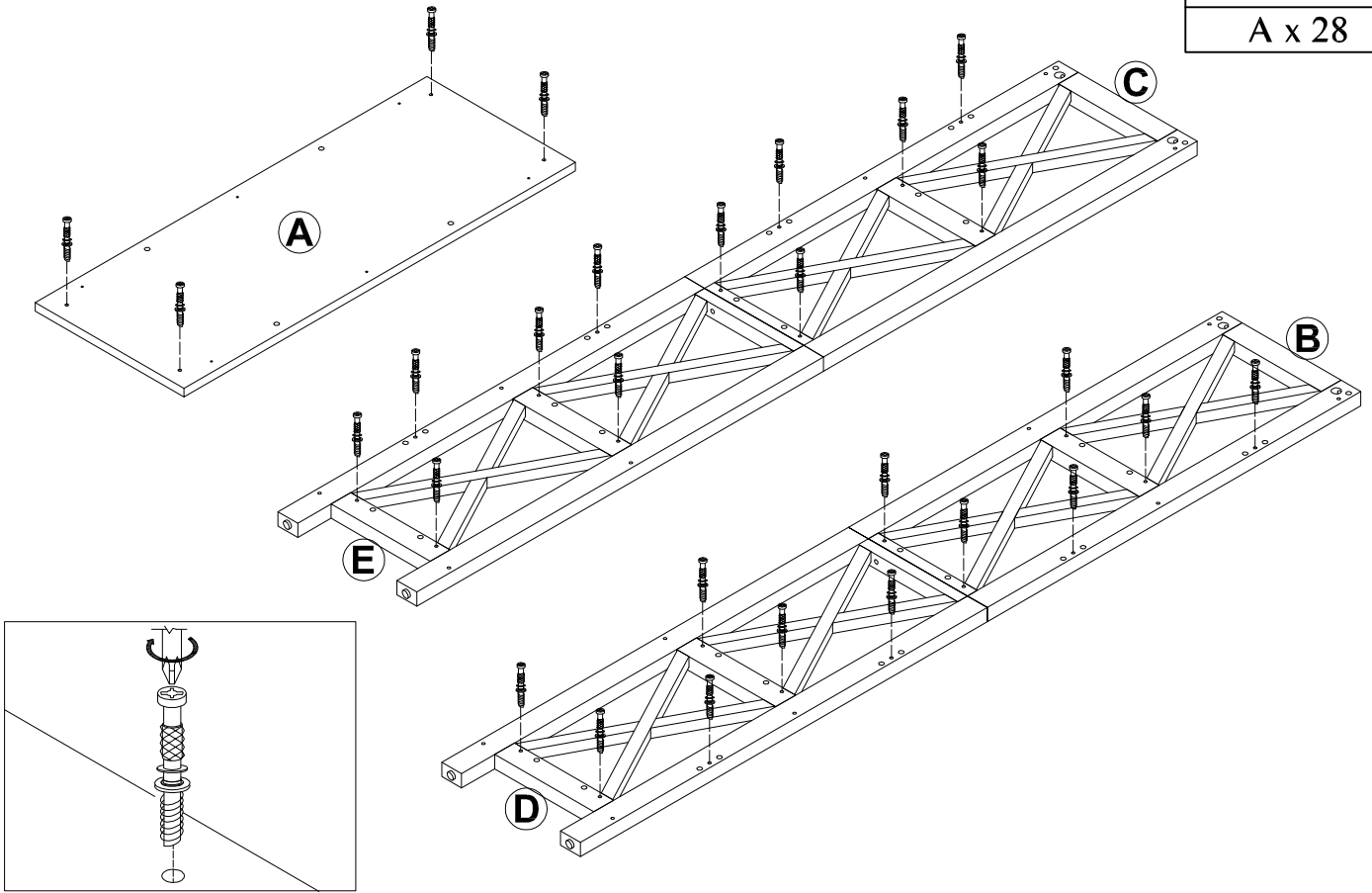
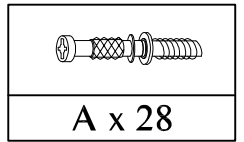

STEP 4

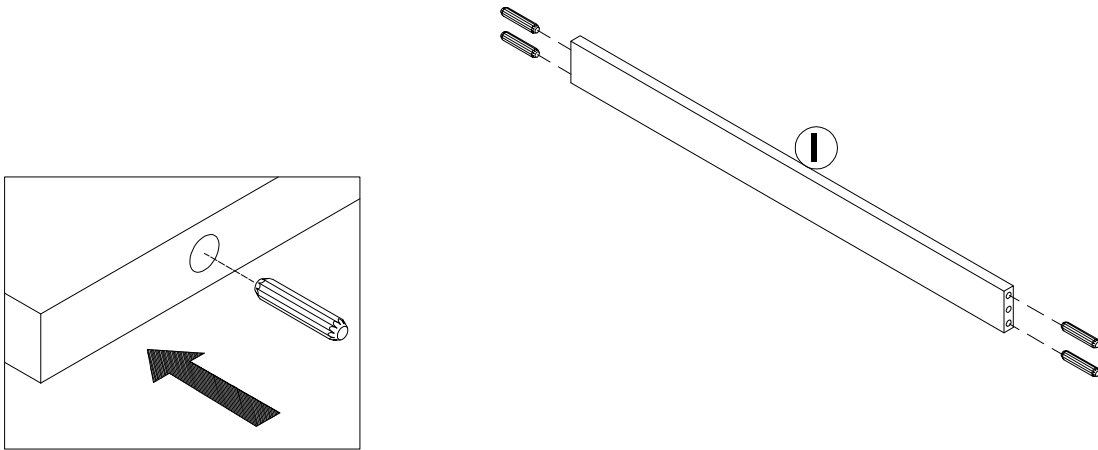
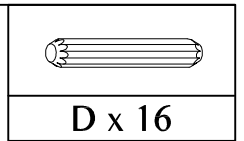

(4X)

STEP 5

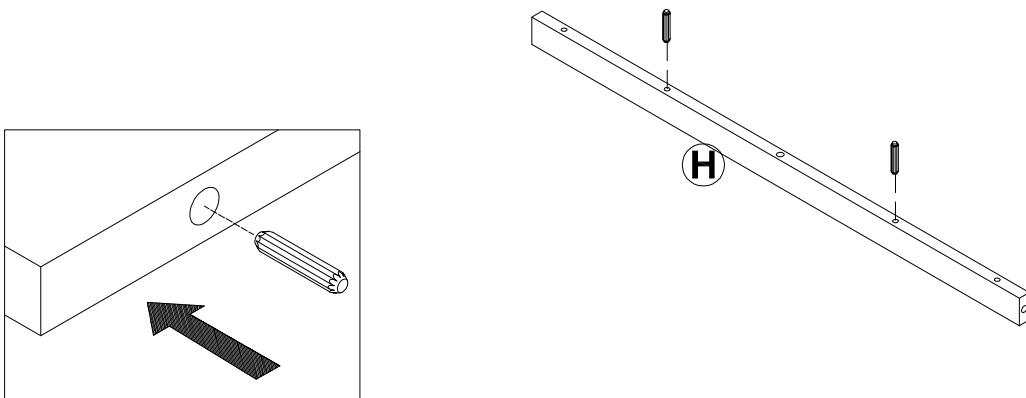
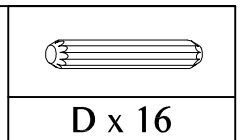

(8X)

STEP 6

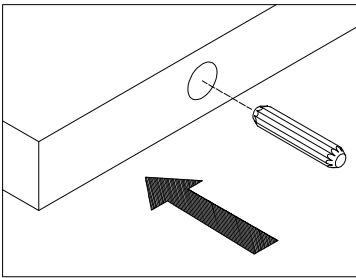
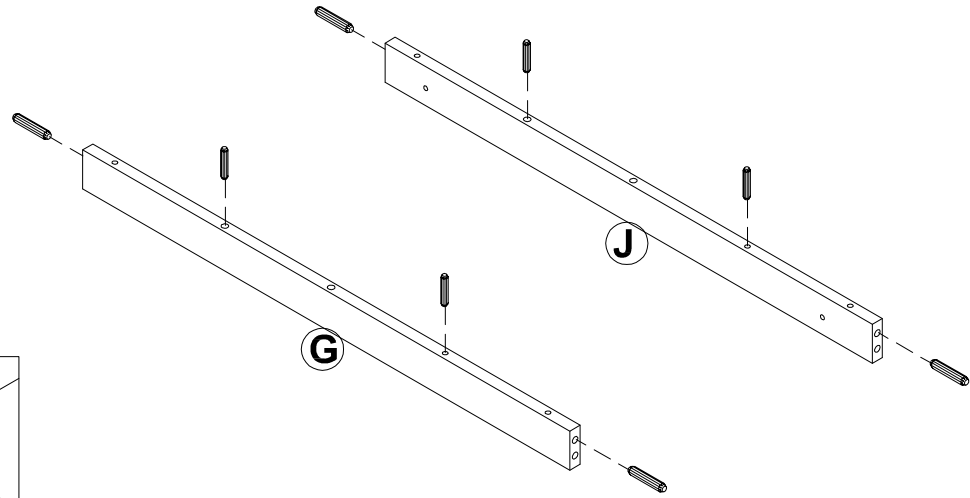
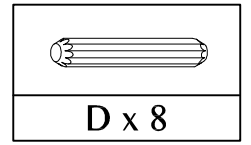

STEP 7

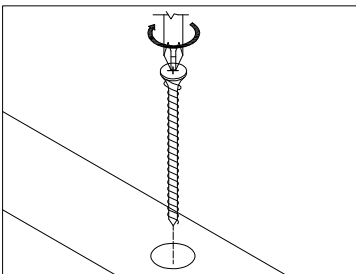
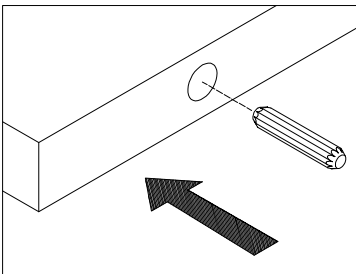
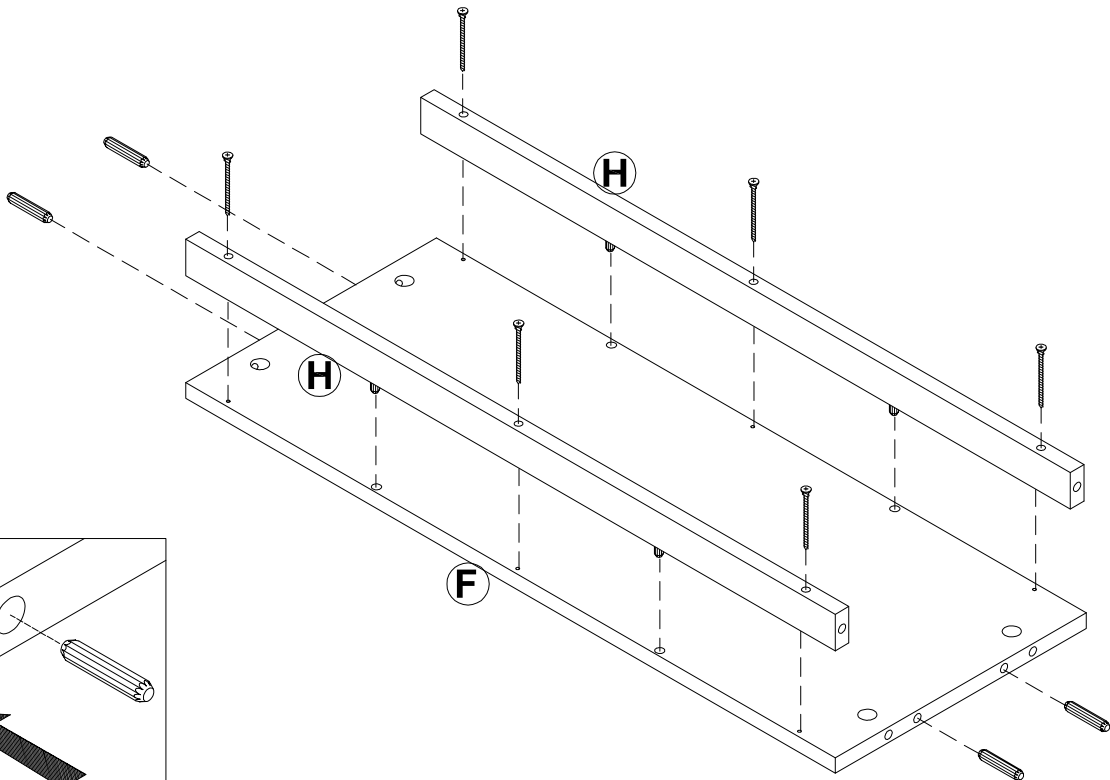
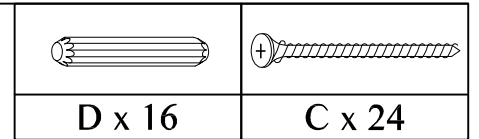

(4X)

STEP 8

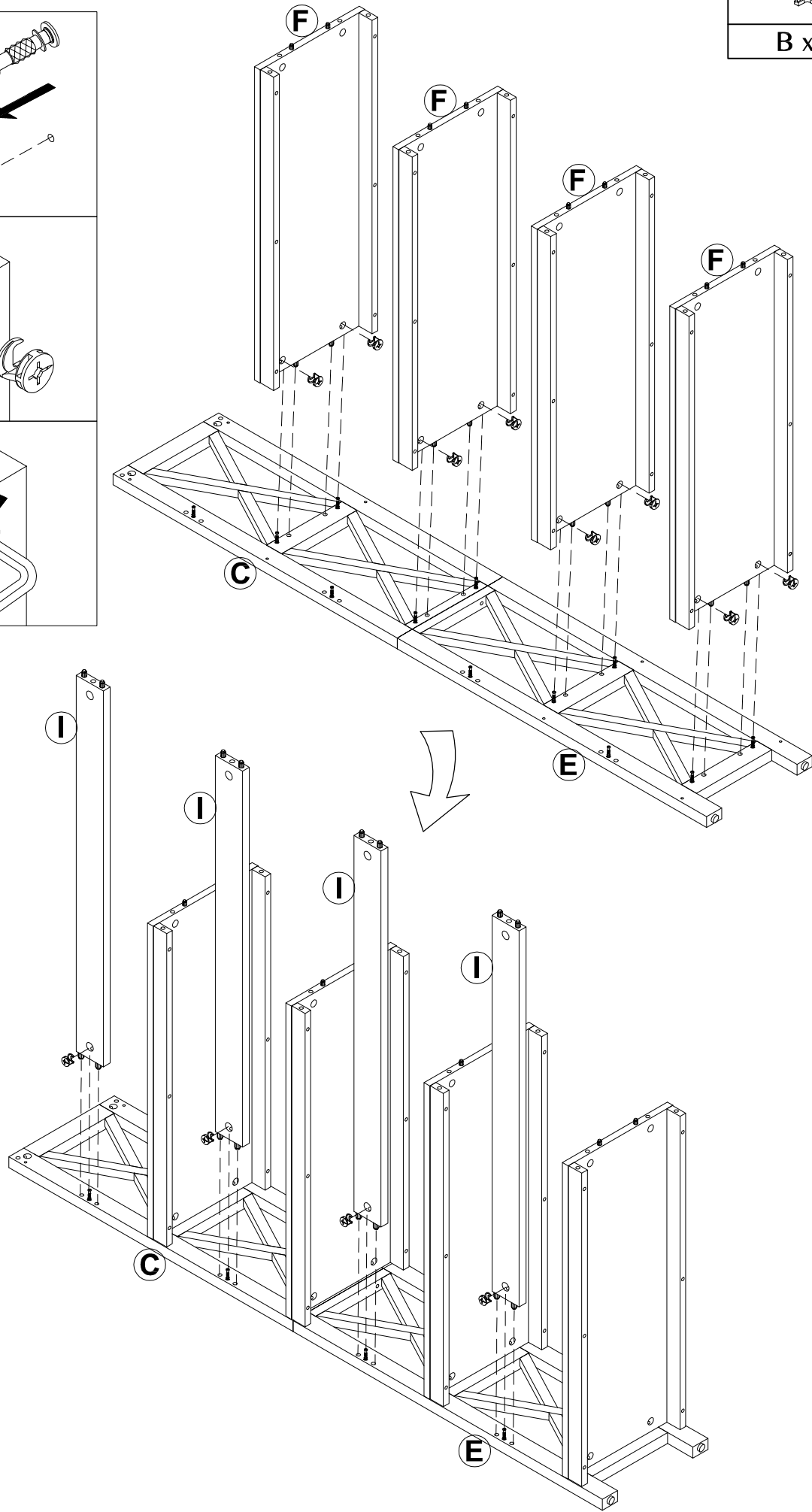
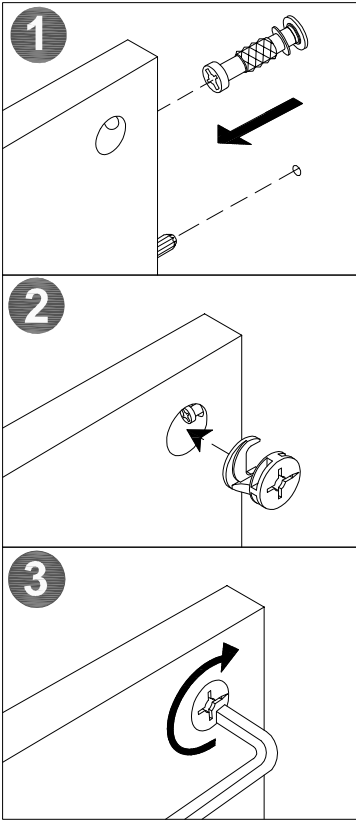
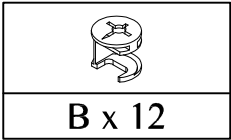

STEP 9

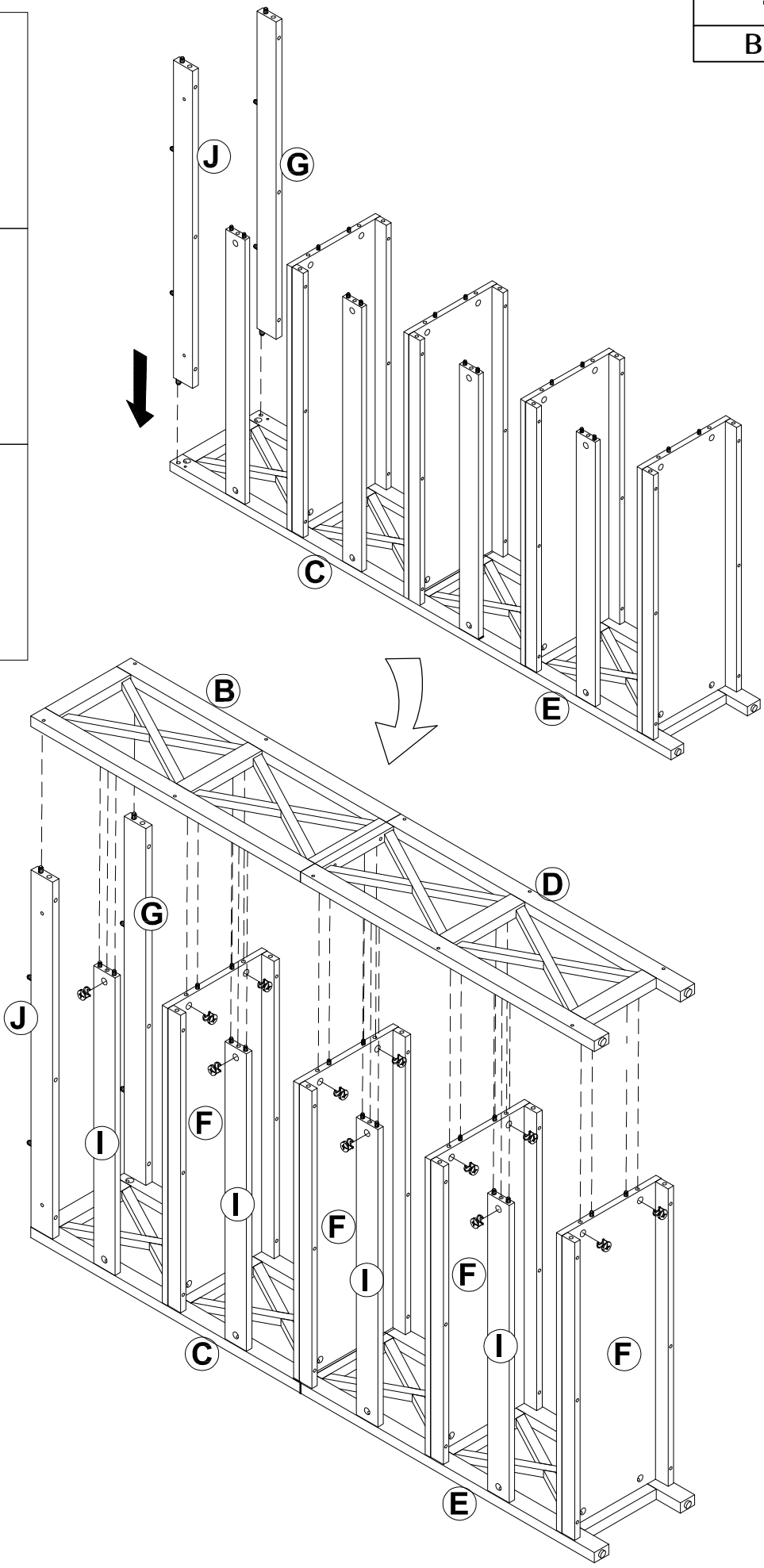
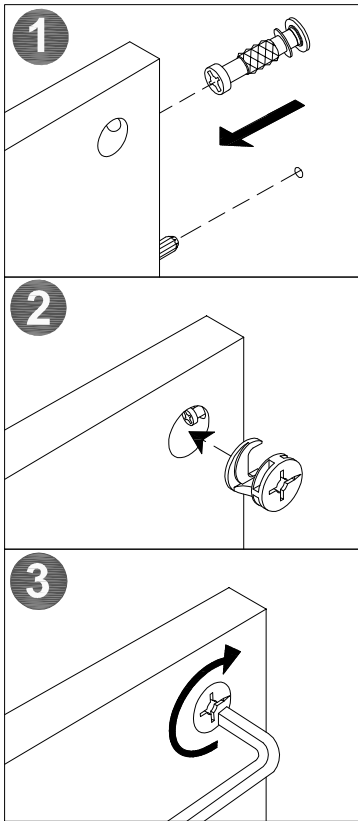
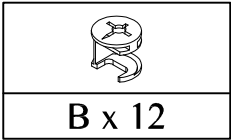

STEP 10

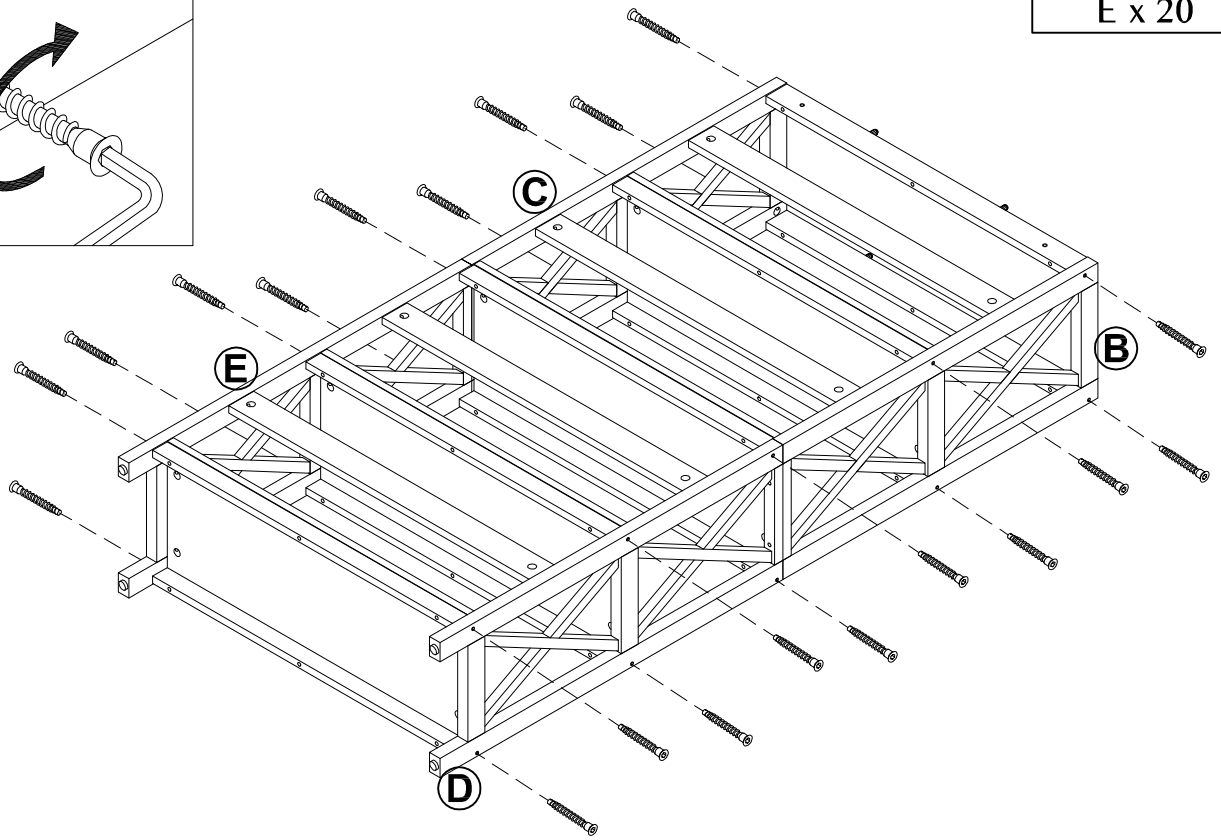
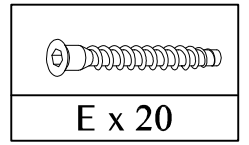
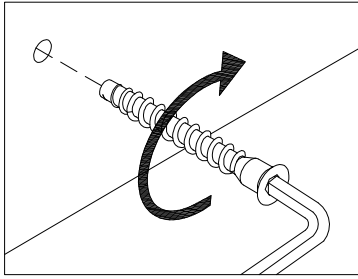

STEP 11

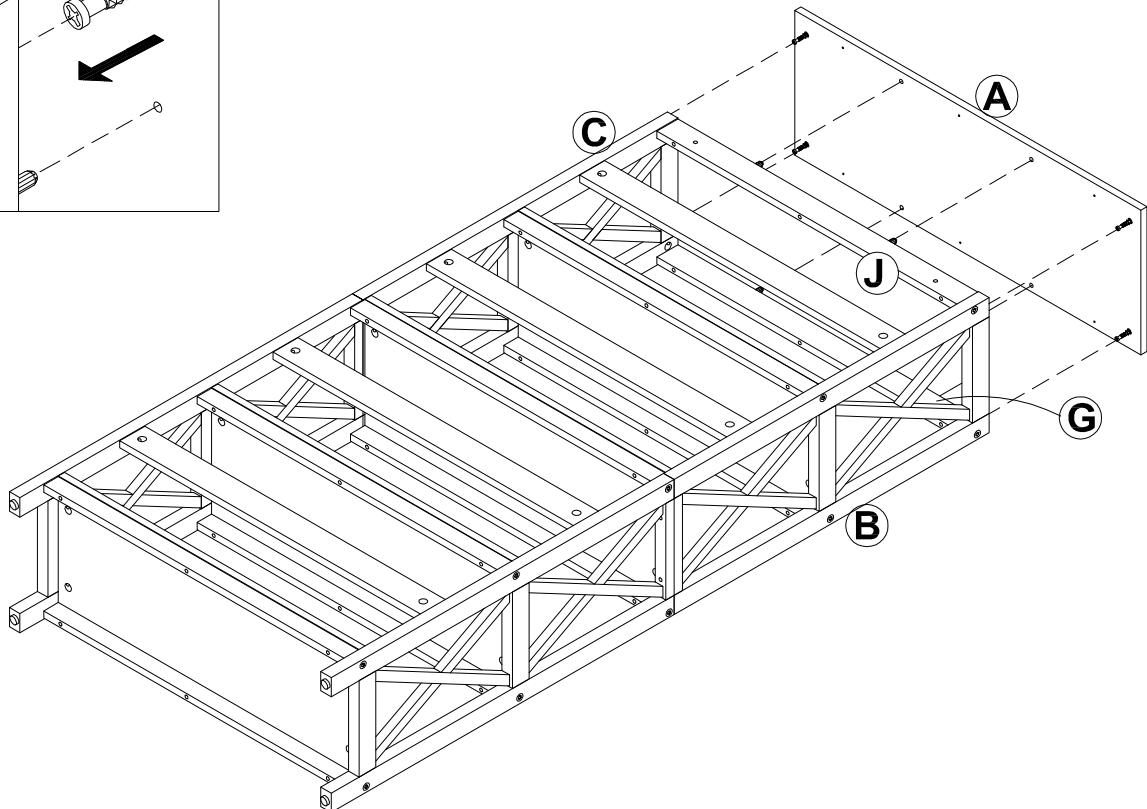
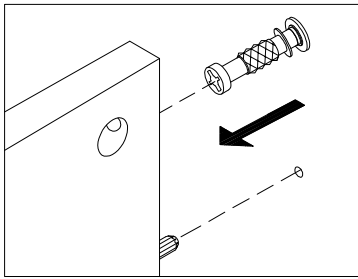

STEP 12

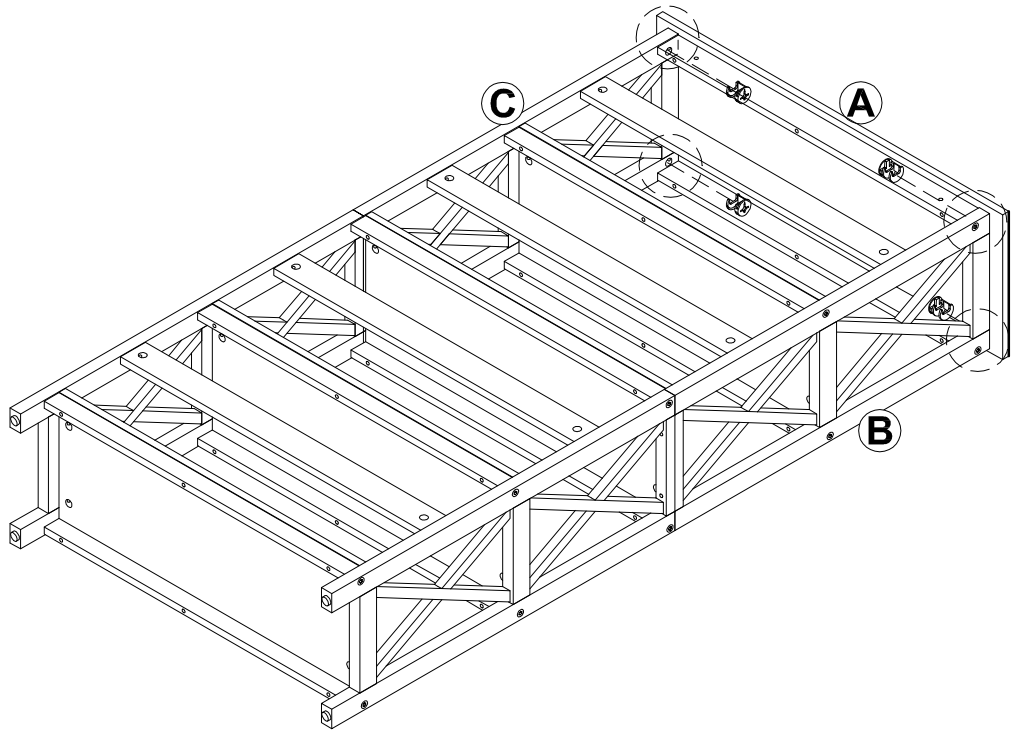
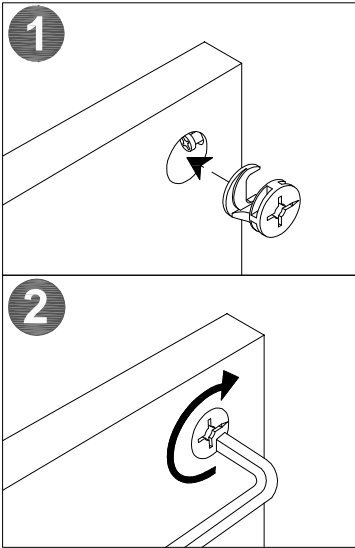
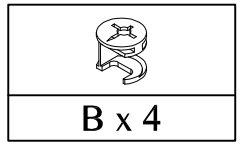

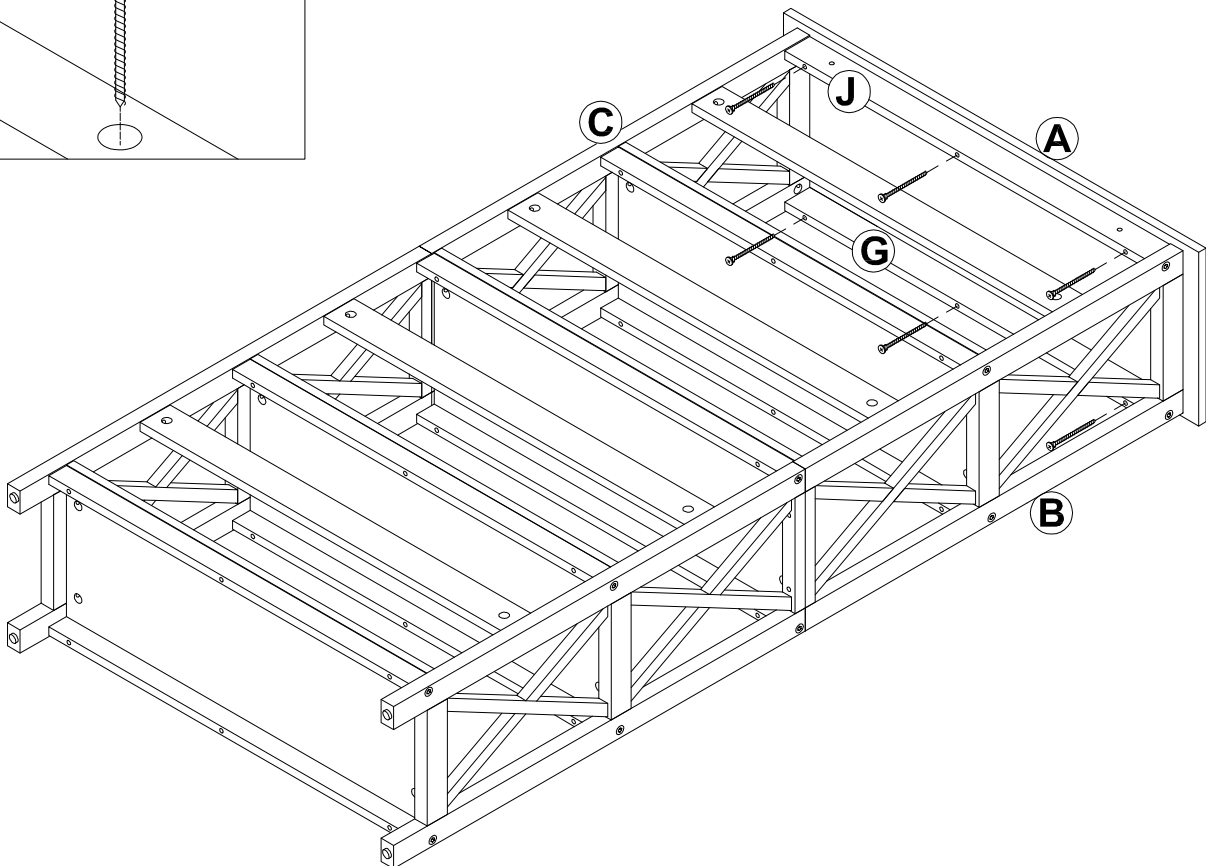
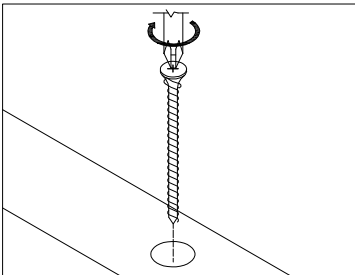
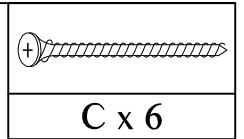

STEP 13

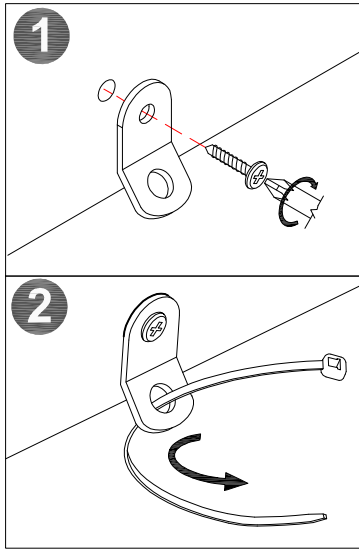

STEP 14

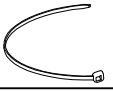

		
J x 2	K x 2	L x 2

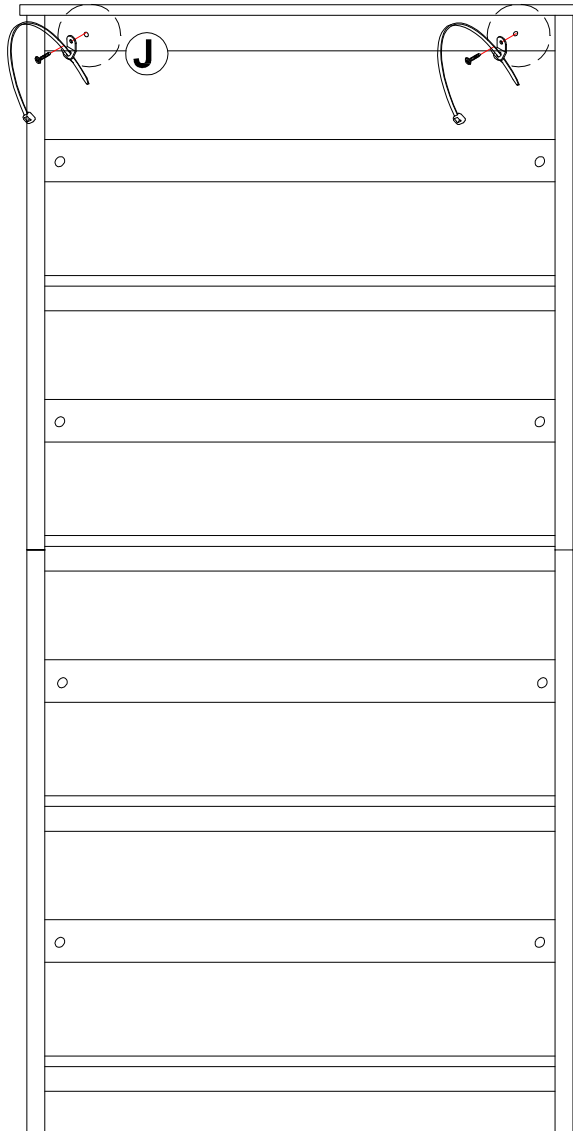
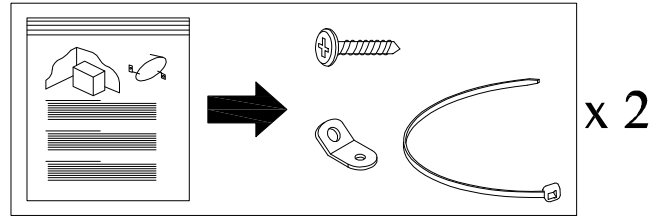

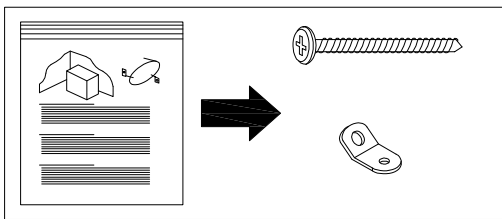
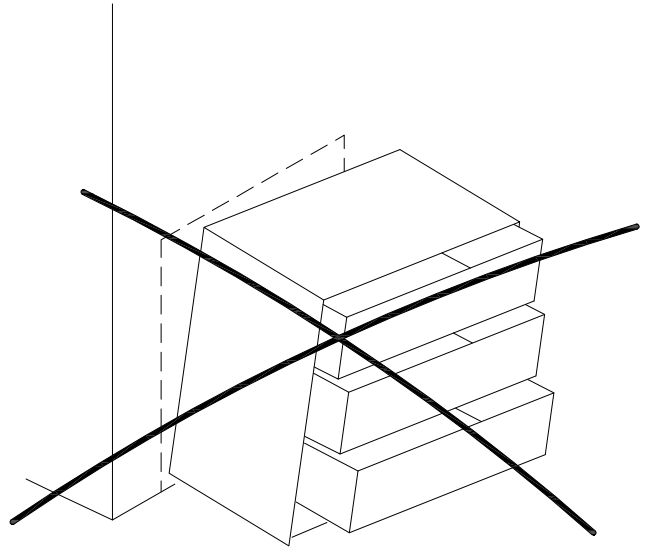
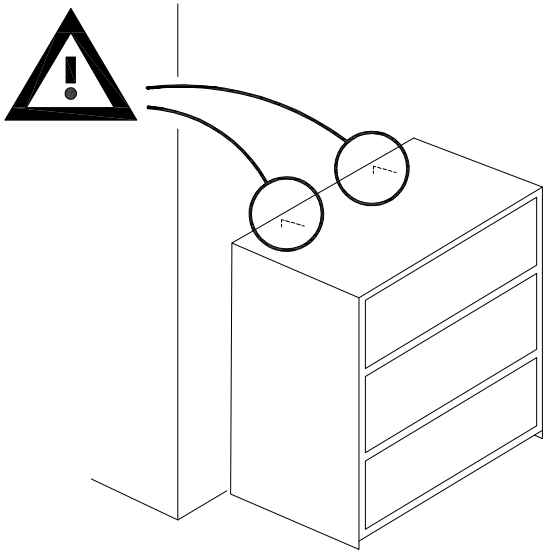

⚠ WARNING ⚠
AVERTISSEMENT / ADVERTENCIA

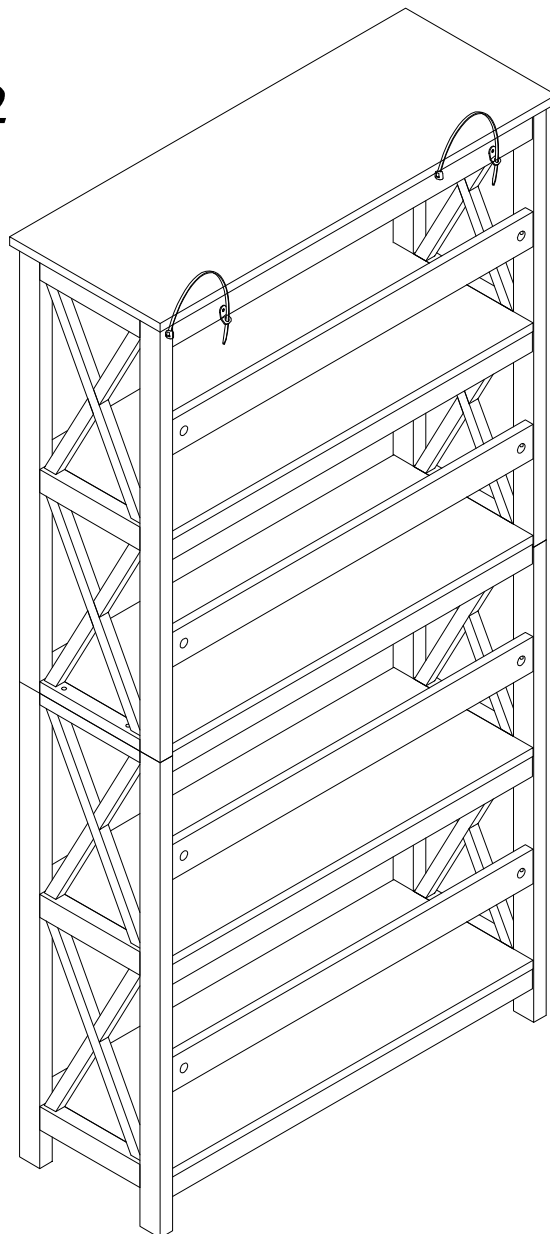

x 2

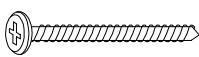

- Move the furniture unit to its final position to the wall.
- Locate a stud in the wall behind the unit. Does not have to be centered.

	
I x 2	K x 2

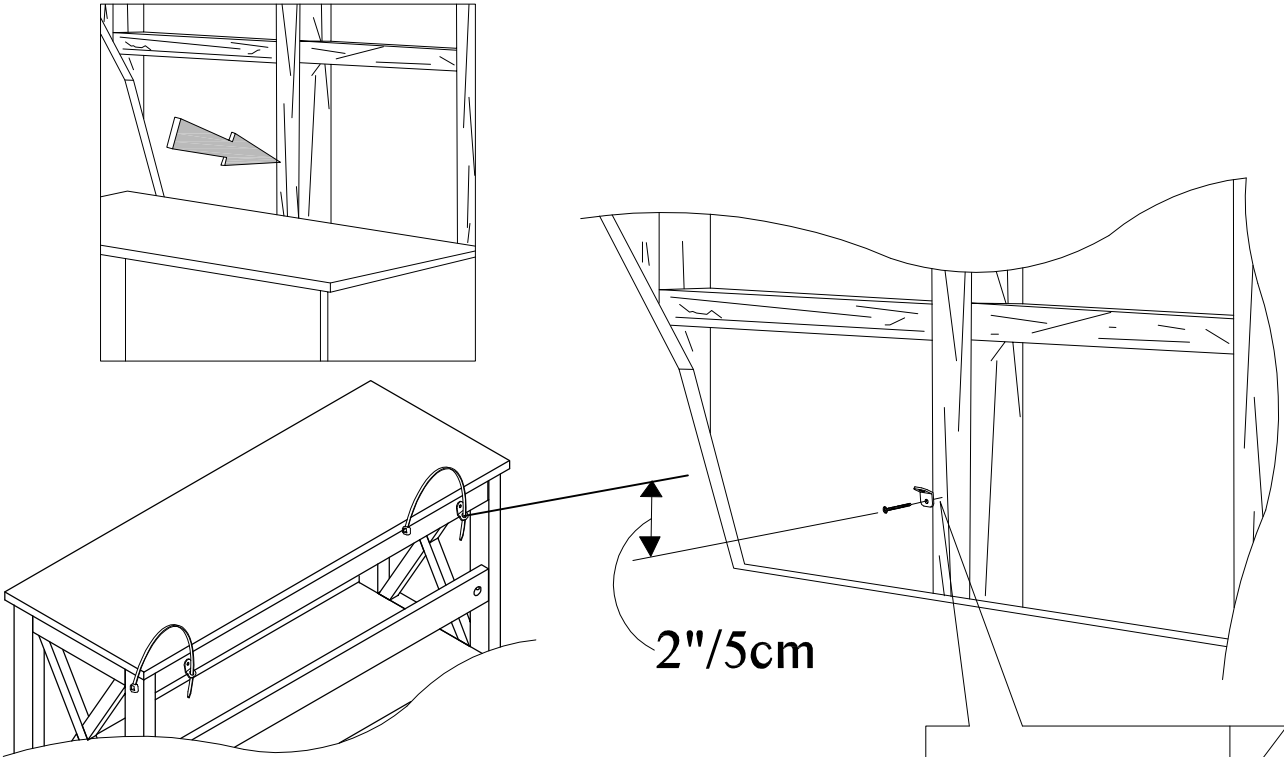

Locate the other bracket on the wall in the wall stud, 2 inches below the mounting bracket secured to the back of your unit. Attach to the wall stud using 2" screw through the smaller hole of bracket.

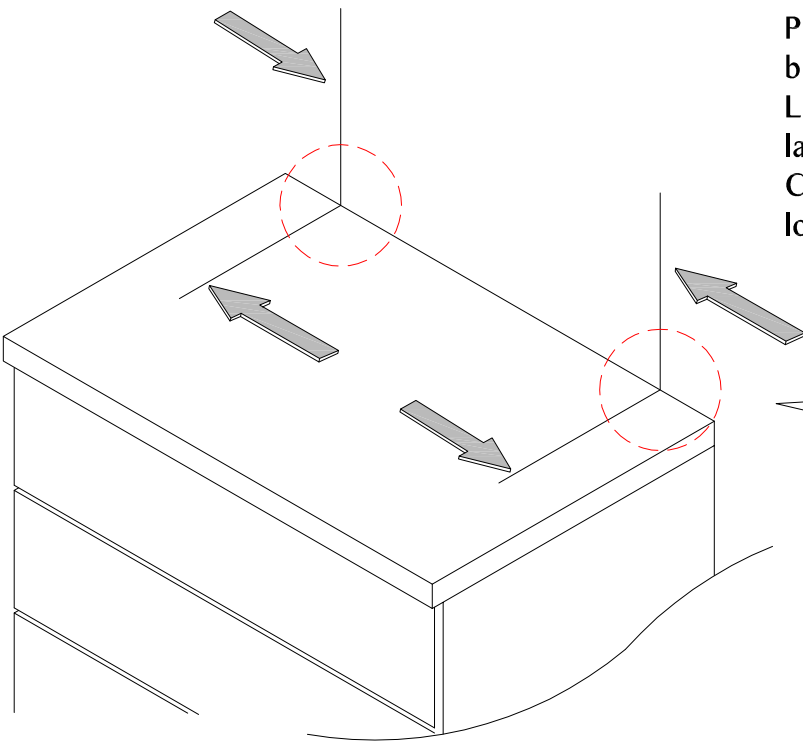
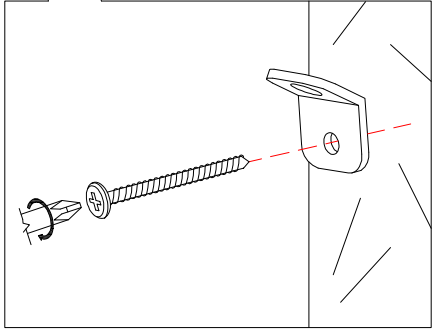

Place the furniture into position so mounting bracket are vertically in line.
Lace the end of the restraint strap through the larger hole in each mounting bracket.
Confirm that the strap is securely laced and locked.

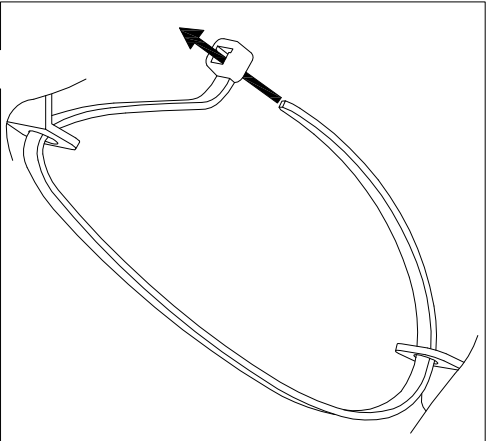

MAXIMUM LOADS CHARGES MAXIMALES / CARGA MAXIMA

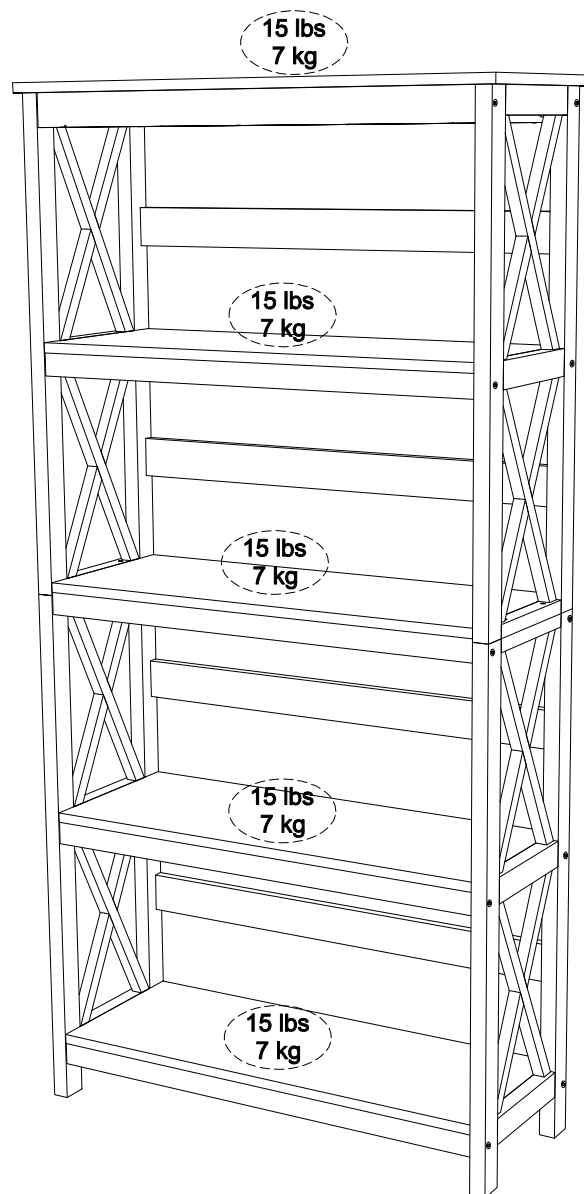

This unit has been designed to support the maximum loads shown. Exceeding these load limits could cause sagging, instability, product collapse, and/or serious injury.

Ce meuble a été conçu pour supporter les charges maximales indiquées. En excédant ces limites de charge, le meuble pourrait devenir instable, s'effondrer, et/ou causer des blessures graves.

Esta unidad ha sido diseñada para soportar la carga máxima anotada. El exceder estos límites puede causar inestabilidad, colapsarse y/o causar serias lesiones.