

WARRANTY

We strive to offer high-quality products, and we also try our best to satisfy each and every customer that orders from us with product or service as needed. We provide 30 days warranty starting from the time you receive the item. Each customer must provide a record of their order such as the order number, or item receipt for any items that are out of the warranty period you may also still receive replacement parts by purchasing them with our company if they are available.

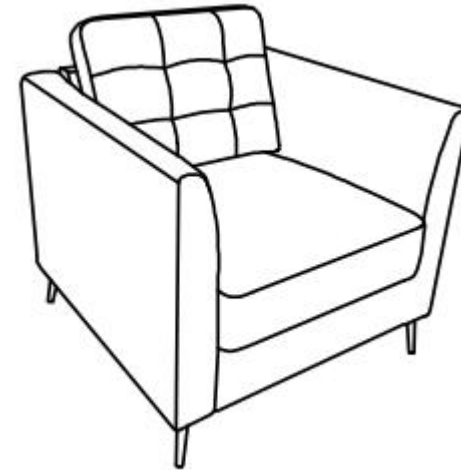

**Appreciated your purchasing from us.
Pop up your life by our furniture piece!**

NOTE:

This brochure contains IMPORTANT safty info. Please read and keep for future reference.

MAINTAINANCE AND WARNING

- Keep furniture away from heat.
- Do not clean furniture with harsh cleansers or polish. Do not use detergents, Solvents, abrasives, spray packs or leather cleaner. Use non-color mild soap with warm water clean spills(Mix 1:10 soap to water)
- Do not place furniture under direct sunlight, material will possibly fade over time.
- Do not use on site dry Cleaning machine.
- Children should not climb or jump on the furniture.
- Do not write on furniture without a padded barrier to protect the surface.
- Not for commercial use, For residential use only.



Weight Limitation

250LBS

PARTS LIST

A: Seat

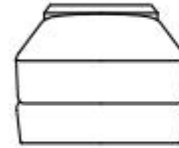

B: Left armrest



C: Right armrest



D: Backrest

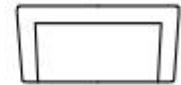

E: Back Cushion



Fx4: Legs



HARDWARE LIST

①x12: bolt
M6*18mm



②x1: allen key
M6x30x80mm



SPARE

①x1: bolt
M6*18mm



Be sure to check all packing material carefully for small parts, which may have come loose inside the carton during shipment.

ASSEMBLY INSTRUCTIONS

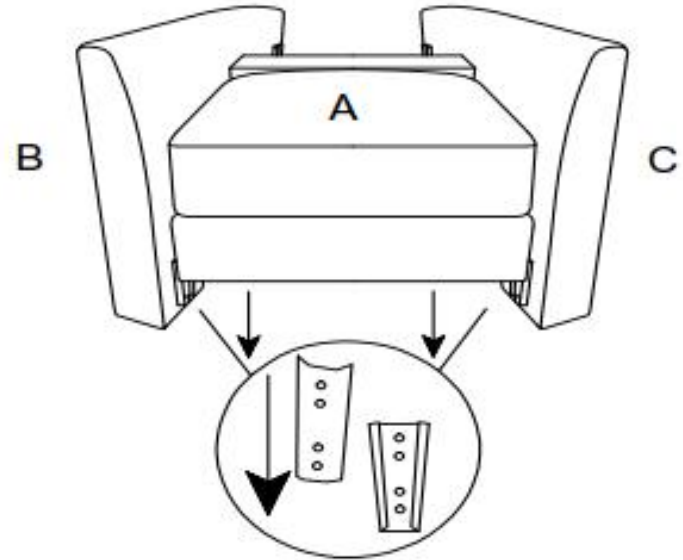

STEP 1:Place the Arms B and C on clean padded surface. Align and insert the metal bracket of seat A downwards into the metal bracket of armrest B and C. Make sure they are connected tightly and secure.

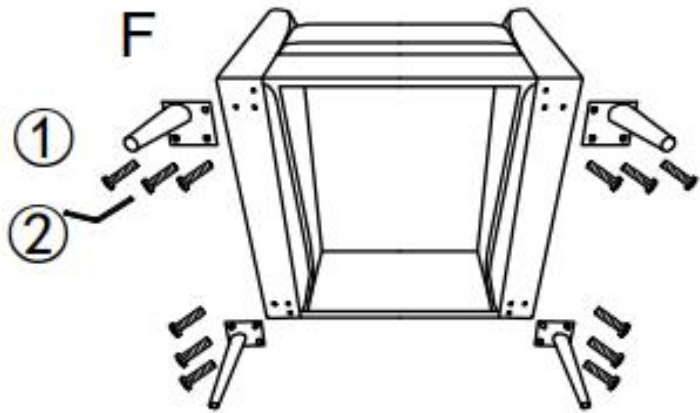

STEP 2: Use bolt ①, allen key ② to attach Leg F to bottom of the armrest, make sure all holes align then fasten bolts to secure.

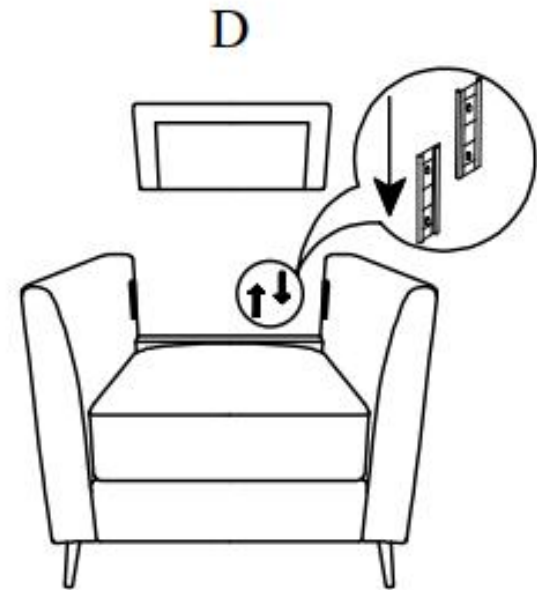

STEP 3: Insert the Back D into chair from the top down. Be sure to have adult partner help to hold both armrests while aligning metal brackets on backrest/armrests.

E



STEP 4:Put the Cushion E on chair. Assembly completed.



Assembly completed.