

# Outdoor storage shed

Product ID. 7AUFW



Scan for Support  
[support@garvee.com](mailto:support@garvee.com)



Distributed by  
**GARVEE**.com

# Assembly Preparation

## Owner's Manual :

Please check local building codes regarding footings, location and other requirements before beginning construction.

## Assembly instructions:

Reviewing all instructions and the appropriate information before you begin, make sure following the step sequence carefully for successful results.

## Flooring base:

A good location for the storage building is a square and level area with good drainage. The base is not included in the kit which may need purchase separately or may construct a foundation and anchoring system of your own.

A strong plastic sheet (thickness: at least 150µm) should be placed under the foundation to assist in reducing rising dampness from the soil, thus reducing condensation build up in the shed. Your storage building must be anchored to prevent wind damage. Once secured, it is highly recommended applying silicone along the inside of the base rail to minimize condensation.

## Parts and Parts List:

Before you start, separate and identify all the parts and hardware to be sure that you have all the necessary parts for your building (refer to the Parts List Page), If you find that a part is missing, please notify the seller within one week after receiving the product. Do not attempt to assemble the building if parts are missing because any building left partially assembled may be seriously damaged by light winds.

## Tools you need:

( Please tear off the safety protection layer before the assembly, keep the part number label if needed)

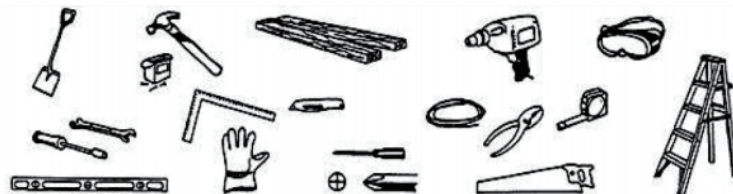

## Safety must be put in the No. 1 position:

1. Select a dry and calm day for your assembly. Team works (Two or more people) are required during the assembly. It is also recommended to finish the assembly in a day to avoid damage to the product or missing of some small parts.
  2. Wearing safety gloves, eye protection and long sleeves during the assembly to prevent injury. Pay attention to the sharp edge of some parts.
  3. Children and pets are not allowed entering into the construction site.
  4. Never concentrate your total weight on the roof of the building.
- When using a step ladder make sure that it is safe.







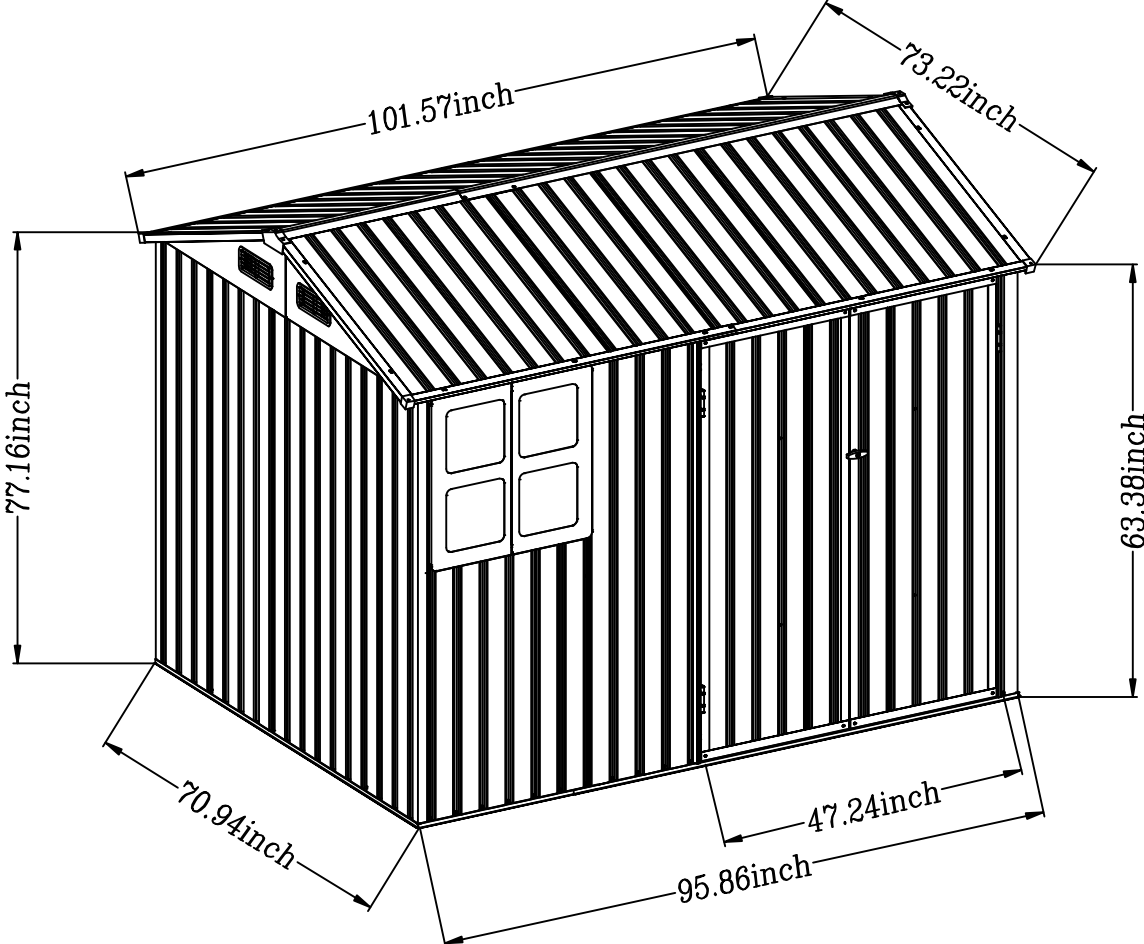



## Care & Maintenance:

1. Keep the shed clean with soft cloth, use water if necessary.
2. Keep the door tracks clear of dirt and other stuff that prevent them from sliding easily.
3. Clean the snow with necessary tools to make sure it is safe to enter into.
4. The shed is not made for living but storing stuff.
5. Please add some oil on the top and bottom door sliding channel to make door slides smoothly.

















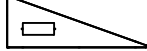
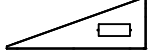





# Size:





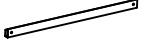



















# F68parts list(A)

| PART  | NO.    | QTY. |
|---|--------|------|
|    | W5     | 10   |
|    | W5-K   | 2    |
|    | F68-7L | 2    |
|    | F68-7M | 8    |
|  | F68-7R | 2    |
|  | W5-C   | 4    |
|  | W3     | 3    |
|  | W2-HL  | 1    |
|  | W2-HR  | 1    |
|  | W5-F   | 1    |
|  | W3-F   | 1    |

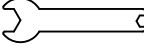
# F68parts list(B)



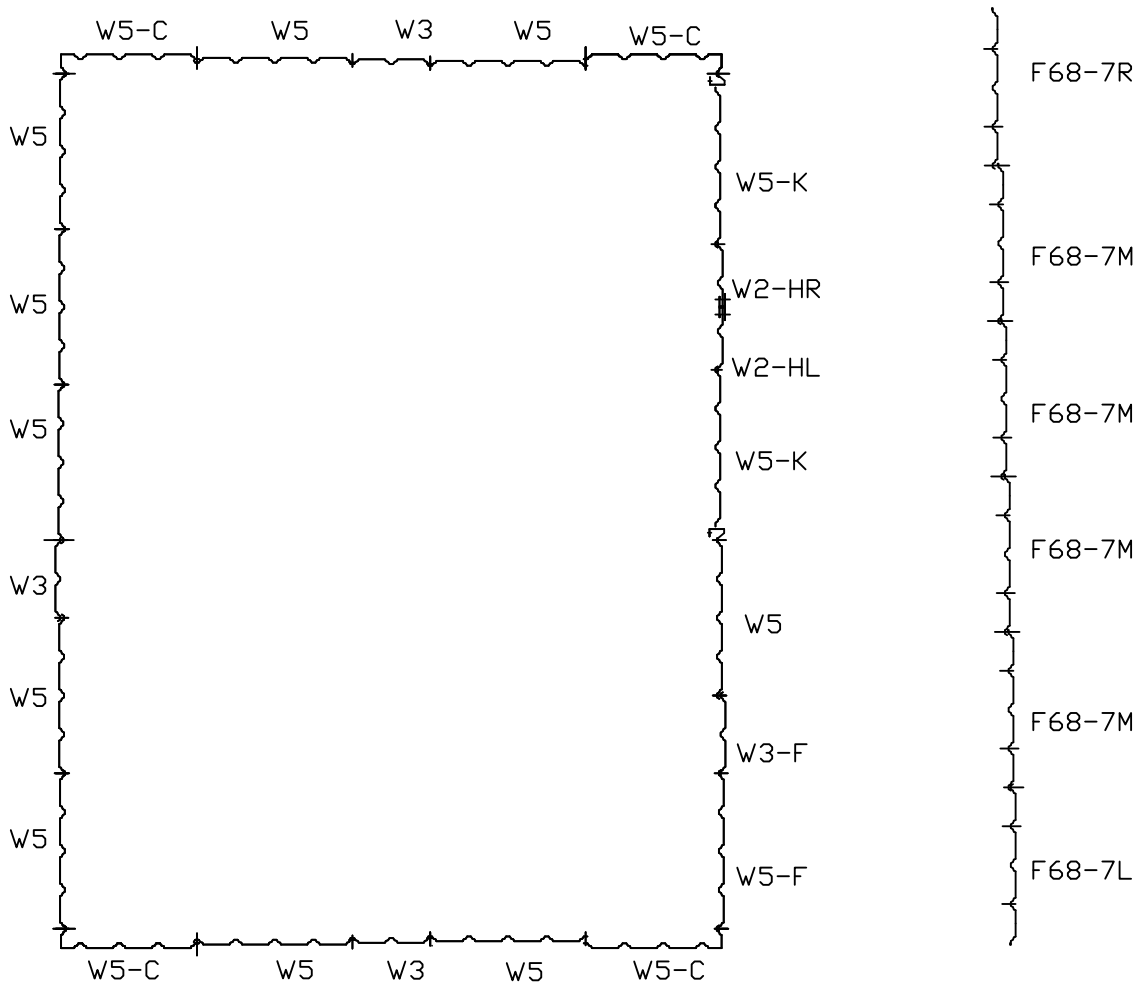

| PART  | NO.      | QTY. |
|---|----------|------|
|    | F68-1    | 2    |
|    | F68-2L   | 2    |
|    | F68-2R   | 2    |
|    | F68-3L   | 2    |
|    | F68-3R   | 2    |
|    | F68-4    | 2    |
|    | K46-5L   | 2    |
|    | K46-5R   | 2    |
|    | K810-6   | 2    |
|   | K810-6R  | 2    |
|  | F68-8    | 4    |
|  | F68-9L   | 2    |
|  | F68-9R   | 2    |
|  | K810-10  | 1    |
|  | K810-10R | 1    |
|  | UA       | 2    |
|  | DA       | 2    |
|  | DLA      | 1    |
|  | DRA      | 1    |
|  | DDA      | 4    |
|  | DBA      | 4    |
|  | C3       | 4    |
|  | TCH      | 2    |

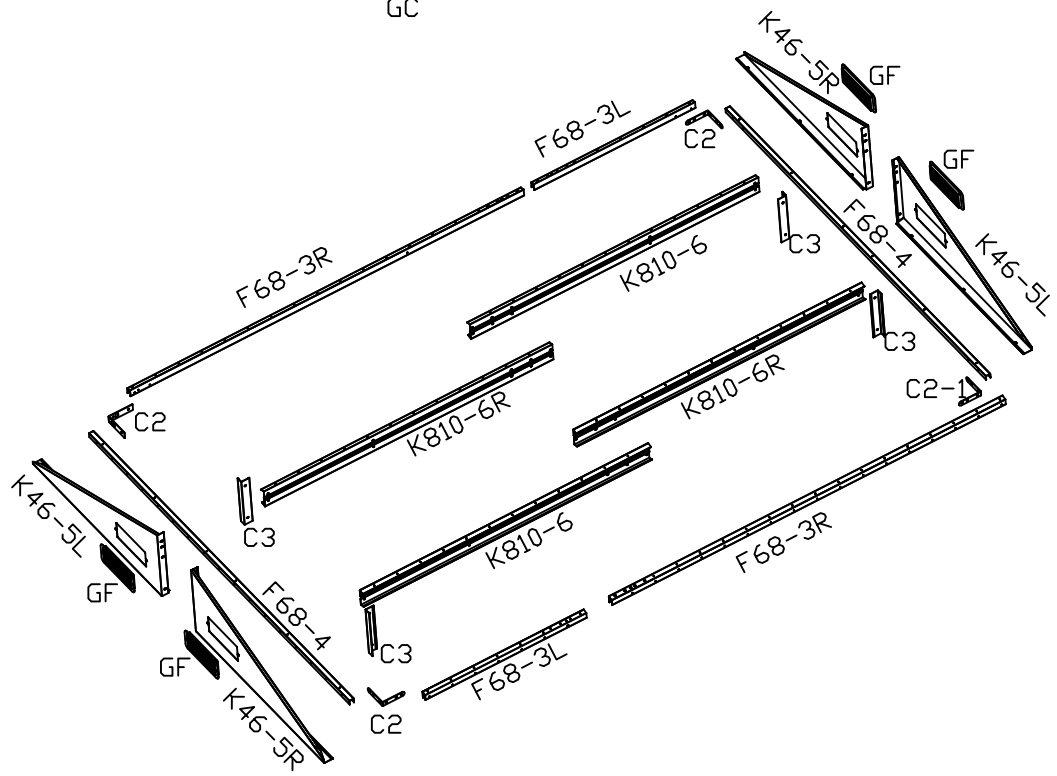
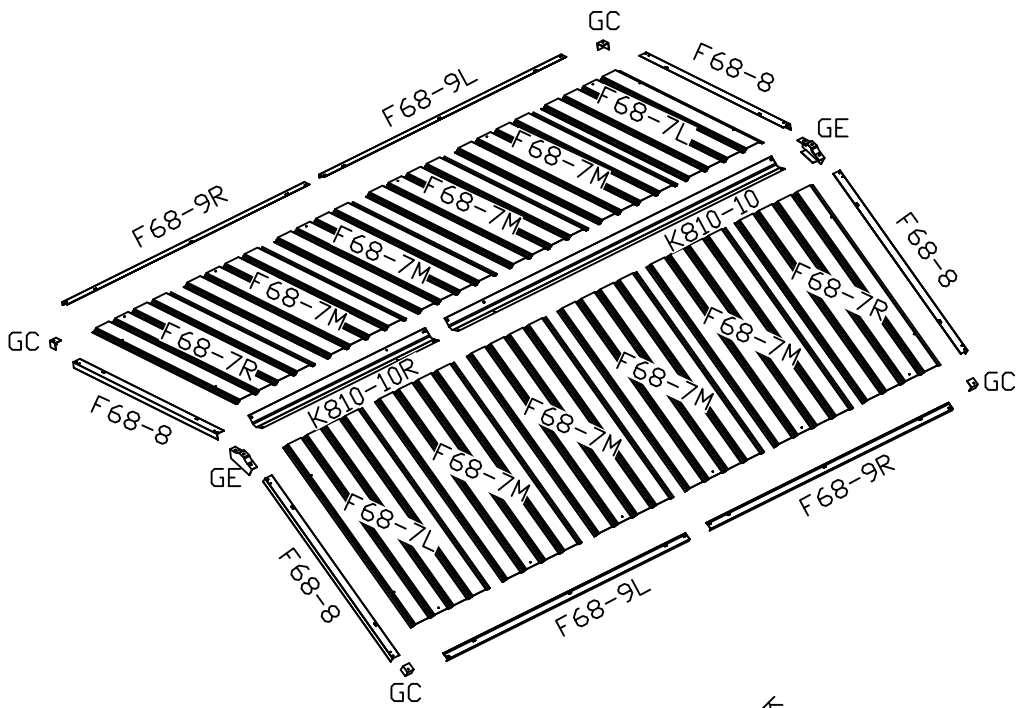
| PART   | NO.         | QTY. |
|--|-------------|------|
|     | TCH3        | 1    |
|    | TCH5        | 1    |
|    | TCH6        | 1    |
|     | TCH7        | 1    |
|     | GC          | 4    |
|     | GE          | 2    |
|     | GF          | 4    |
|     | T-F         | 4    |
|     | F1          | 375  |
|    | F2          | 54   |
|   | F3          | 32   |
|   | V2          | 136  |
|   | F4          | 4    |
|   | DC          | 2    |
|   | C2-1        | 1    |
|   | C2          | 3    |
|   | DH          | 4    |
|   | GL          | 1    |
|   | SL          | 46   |
|  | M20         | 1    |
|   | ST          | 1    |
|   | LED         | 1    |
|   | 3M adhesive | 1    |

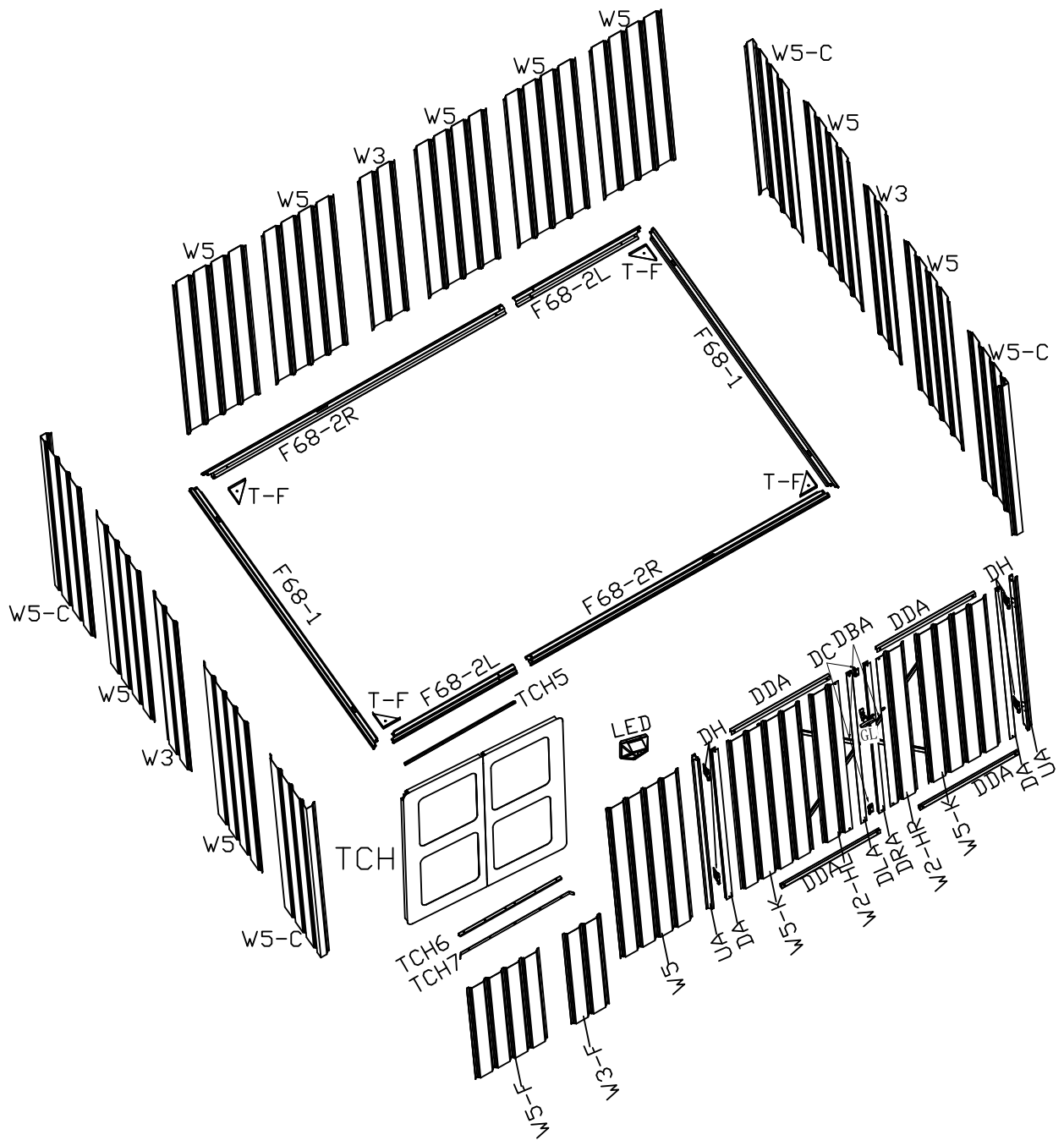



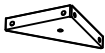



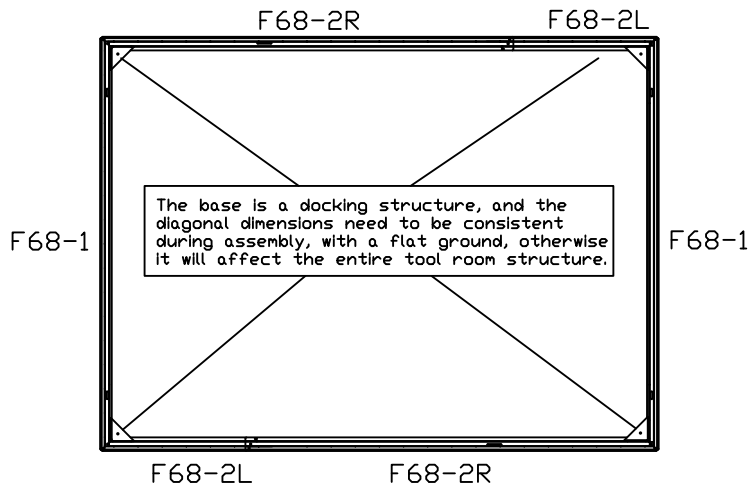
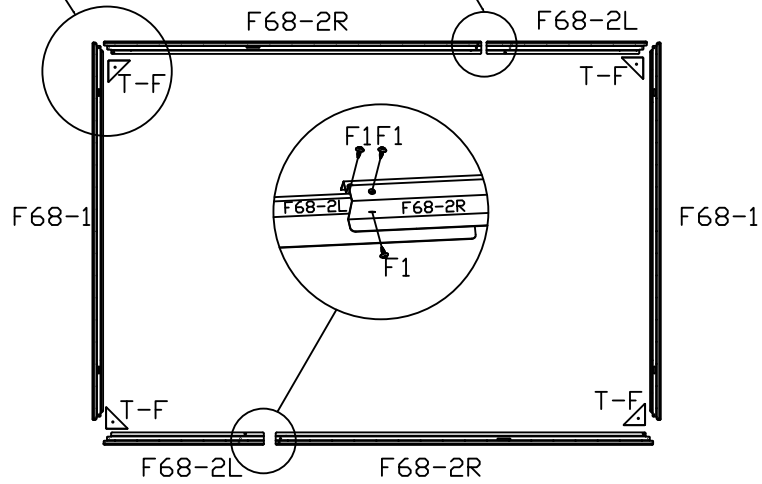
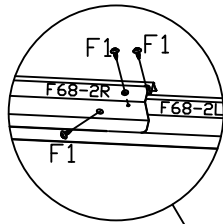
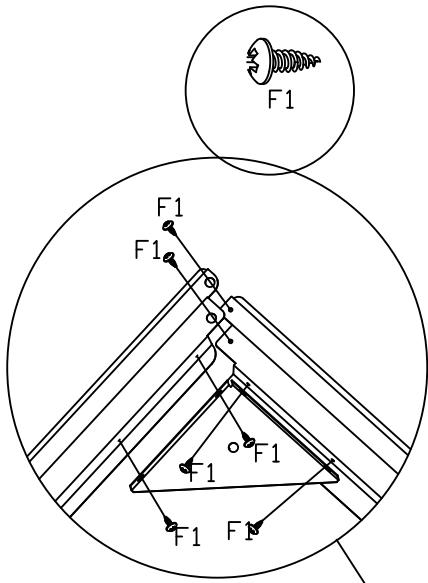

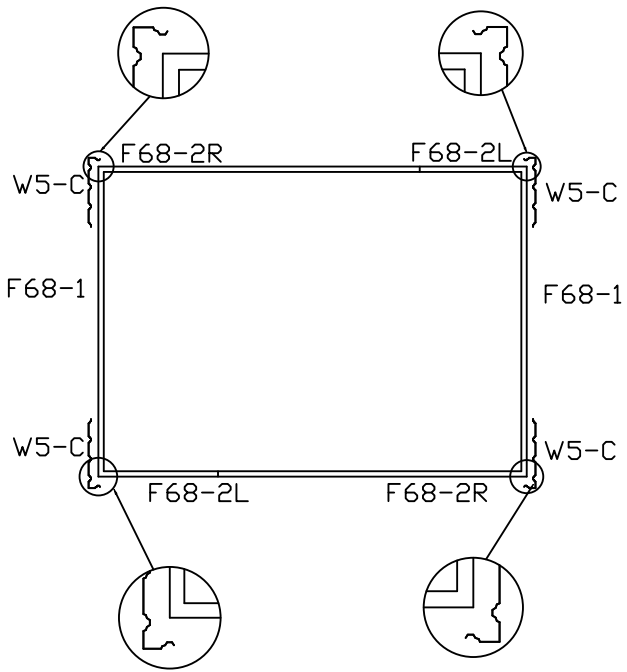



| PART  | NO.    | QTY. |
|---|--------|------|
|   | F68-1  | 2    |
|   | F68-2L | 2    |
|   | F68-2R | 2    |
|  | T-F    | 4    |
|  | F1     | 30   |

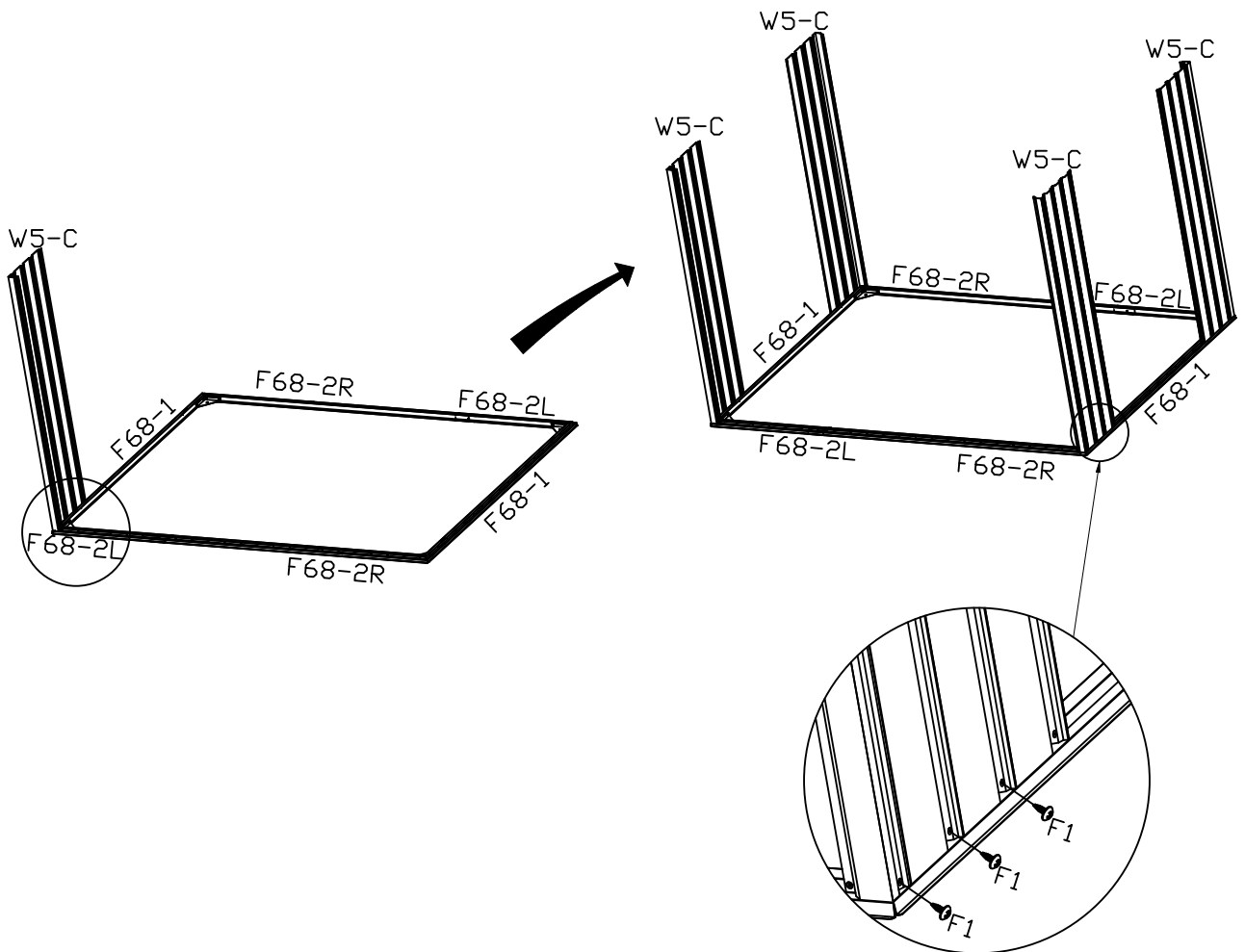



| PART   | NO.  | QTY. |
|--|------|------|
|  | W5-C | 4    |
|  | F1   | 12   |



| PART  | NO.    | QTY. |
|---|--------|------|
|  | F68-3L | 2    |
|  | F68-3R | 2    |
|  | F68-4  | 2    |
|  | F1     | 36   |
|  | C2-1   | 1    |
|  | C2     | 3    |

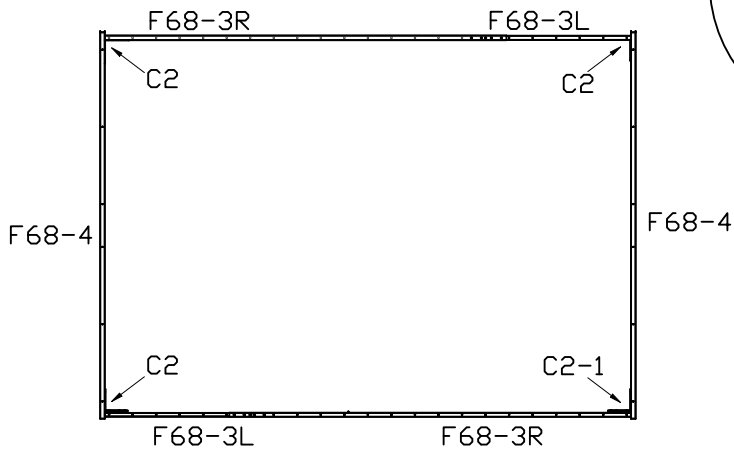
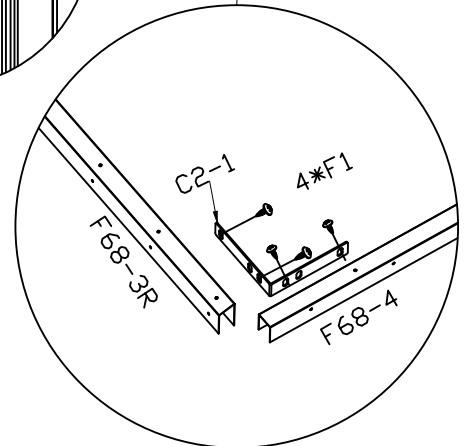
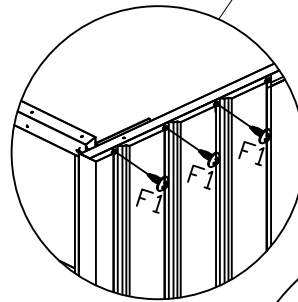
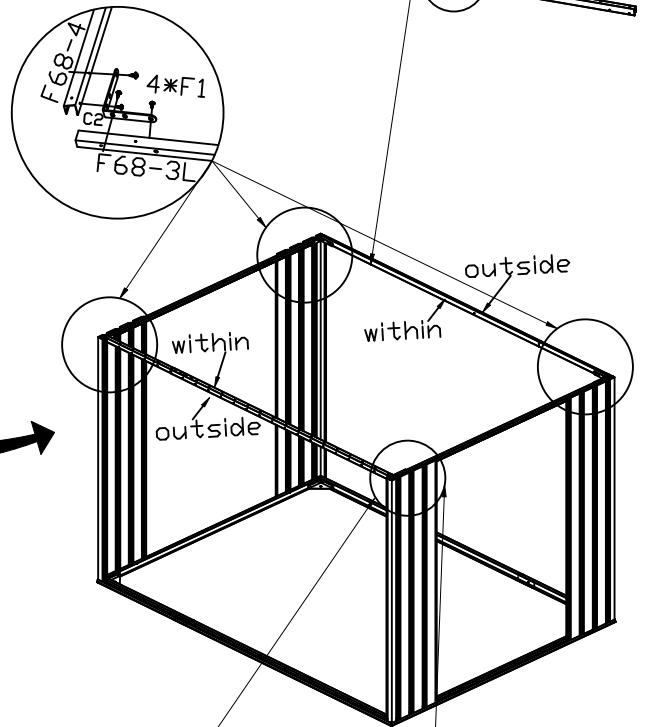
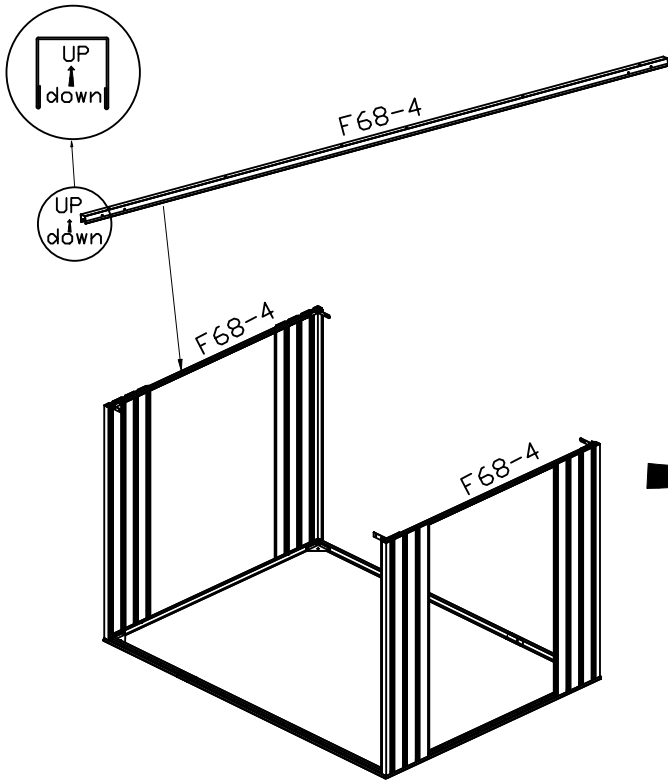
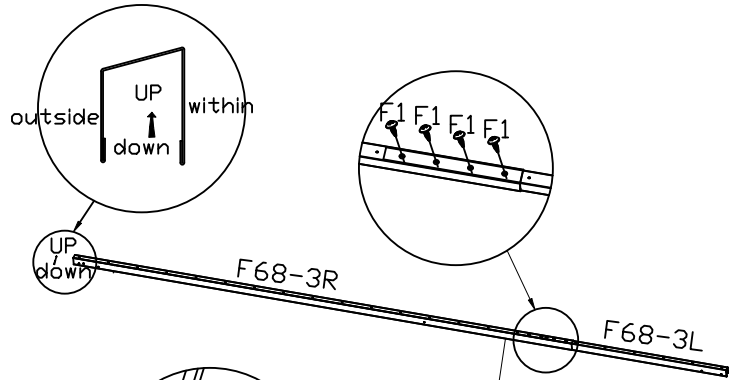

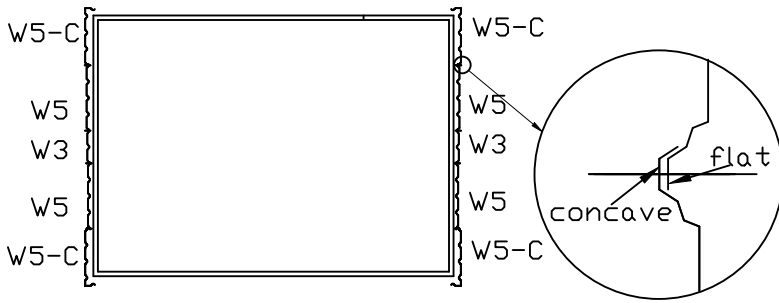

| PART | NO. | QTY. |
|------|-----|------|
|      | W5  | 4    |
|      | W3  | 2    |
|      | F1  | 44   |
|      | F2  | 8    |

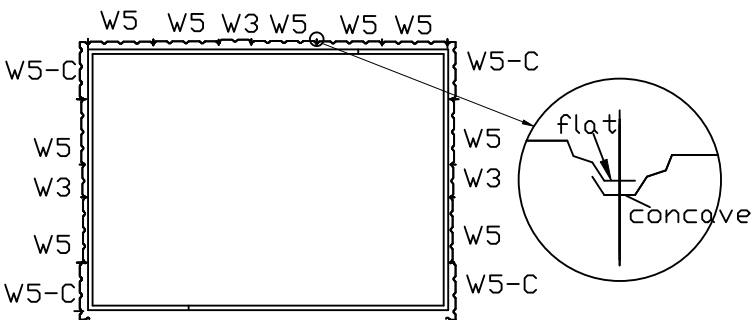
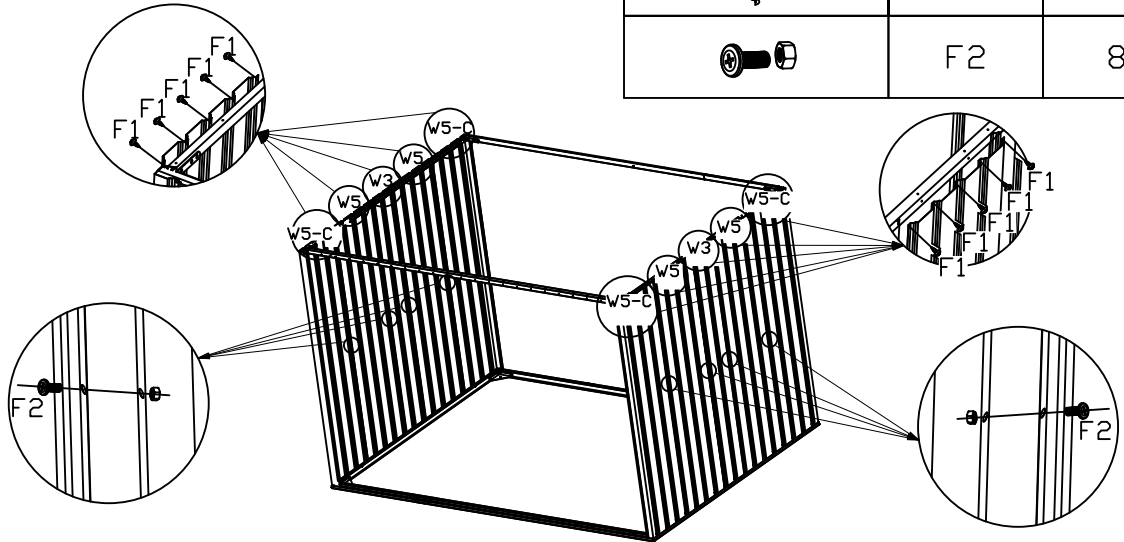

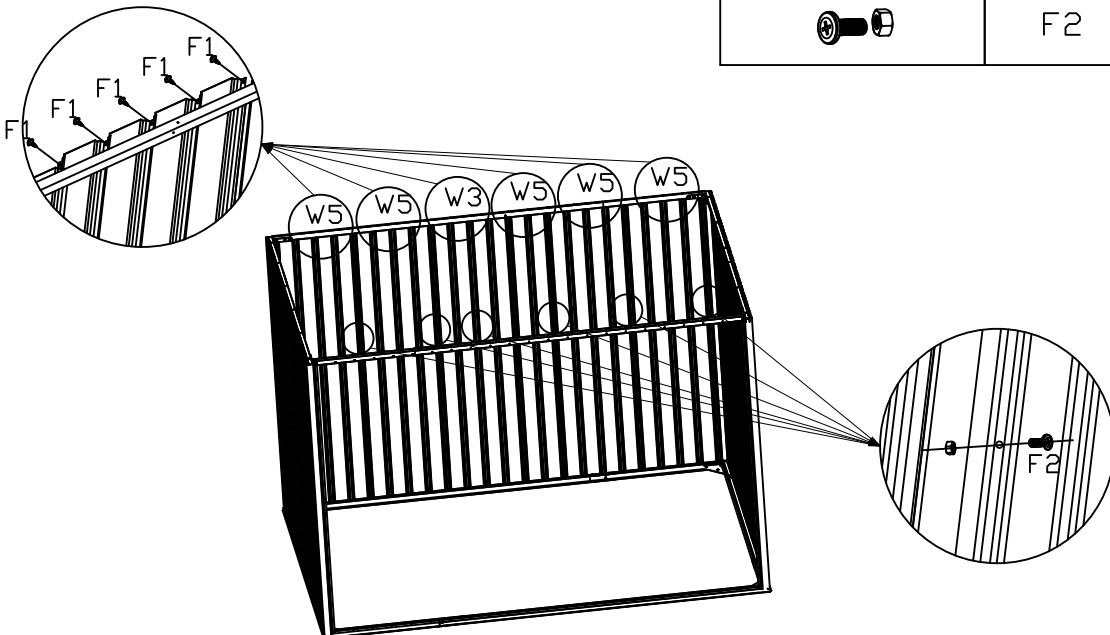

| PART | NO. | QTY. |
|------|-----|------|
|      | W5  | 5    |
|      | W3  | 1    |
|      | F1  | 46   |
|      | F2  | 7    |

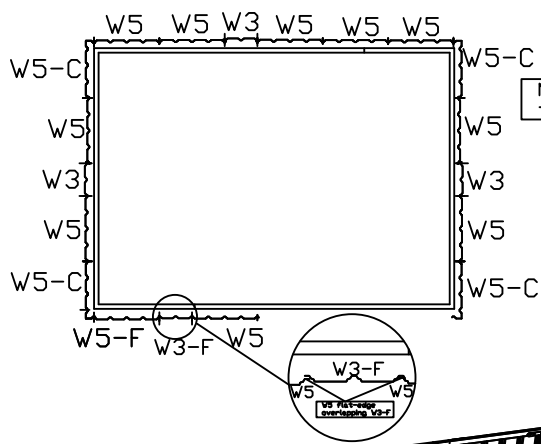



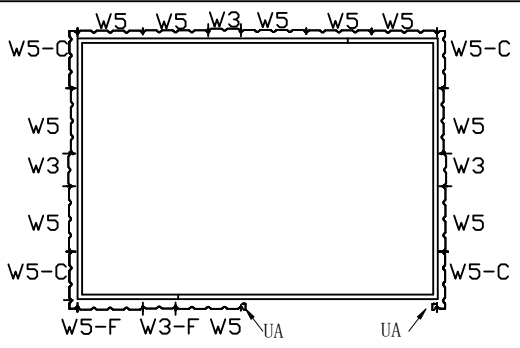
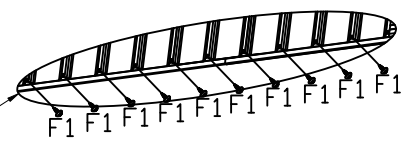
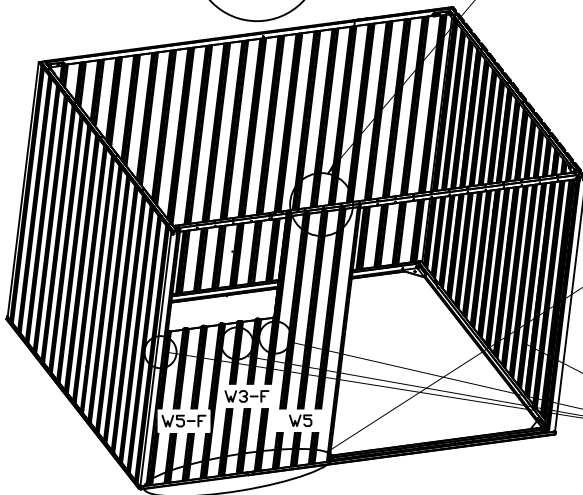

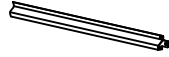

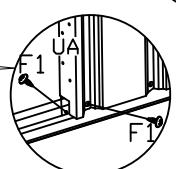
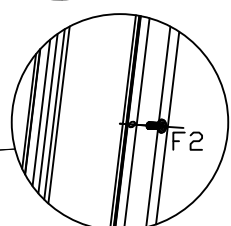
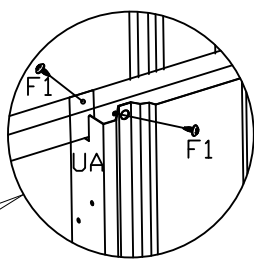
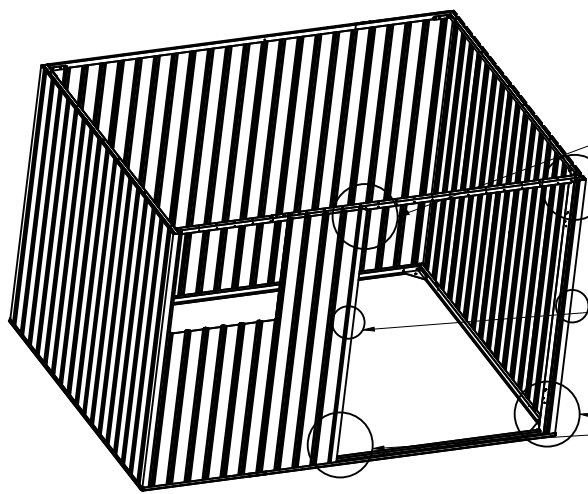

| PART  | NO.  | QTY. |
|---|------|------|
|  | W5-F | 1    |
|  | W3-F | 1    |
|   | W5   | 1    |
|  | F1   | 13   |
|  | F2   | 3    |

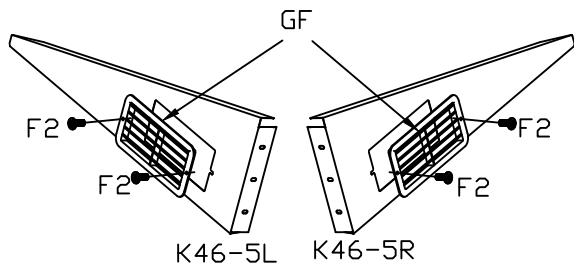

| PART   | NO. | QTY. |
|--|-----|------|
|  | UA  | 2    |
|  | F1  | 8    |
|  | F2  | 2    |







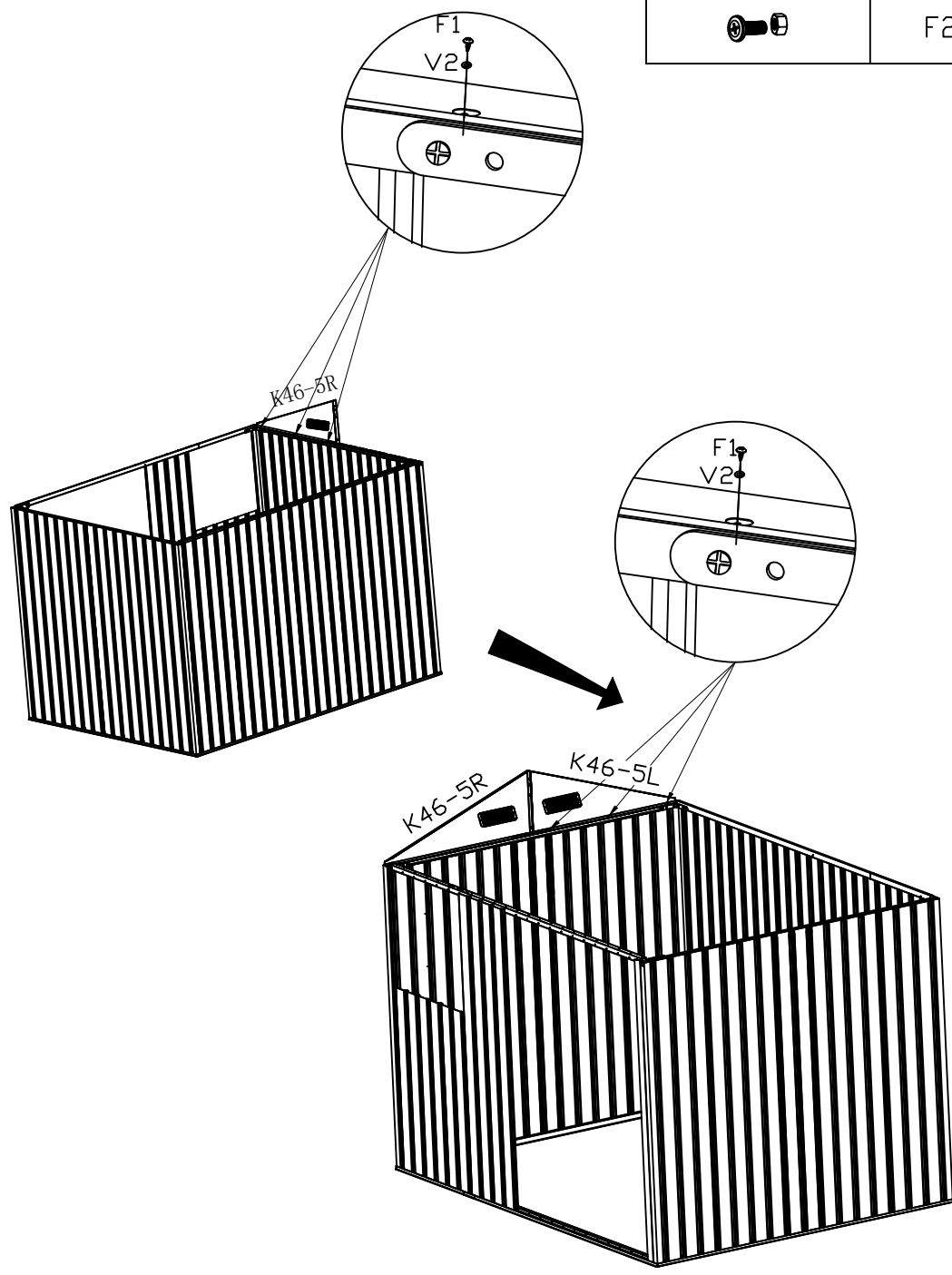

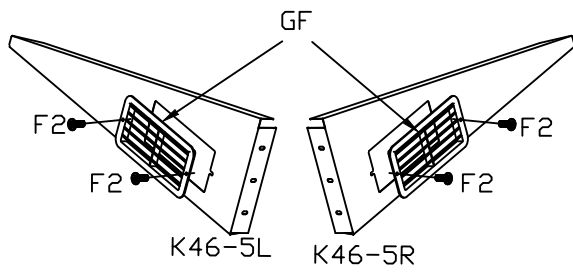

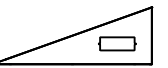
| PART  | NO.    | QTY. |
|---|--------|------|
|  | K46-5L | 1    |
|   | K46-5R | 1    |
|  | F1     | 6    |
|  | V2     | 6    |
|  | GF     | 2    |
|  | F2     | 4    |





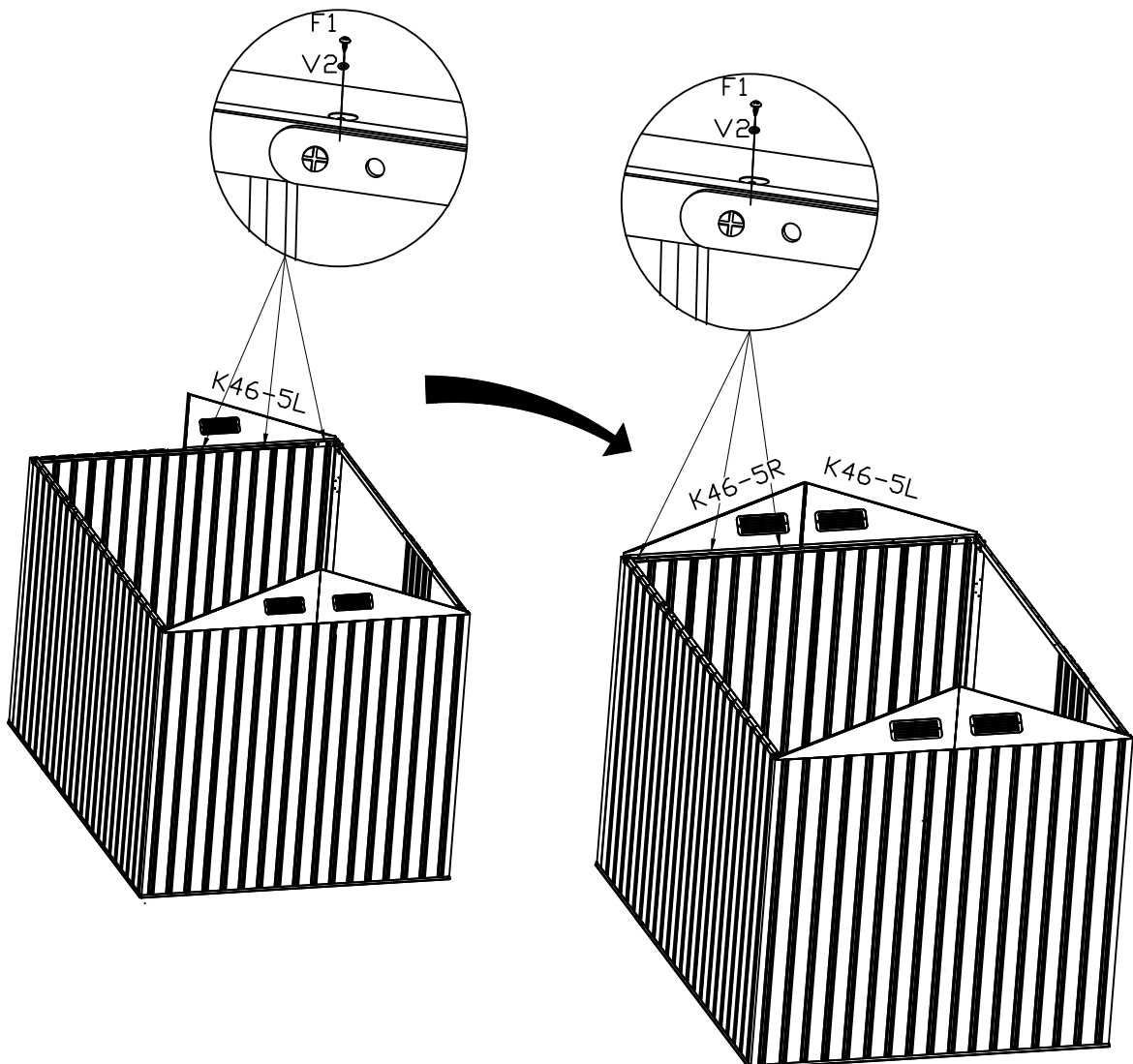

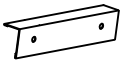

| PART  | NO.    | QTY. |
|---|--------|------|
|  | K46-5L | 1    |
|  | K46-5R | 1    |
|  | F1     | 6    |
|  | V2     | 6    |
|  | GF     | 2    |
|  | F2     | 4    |

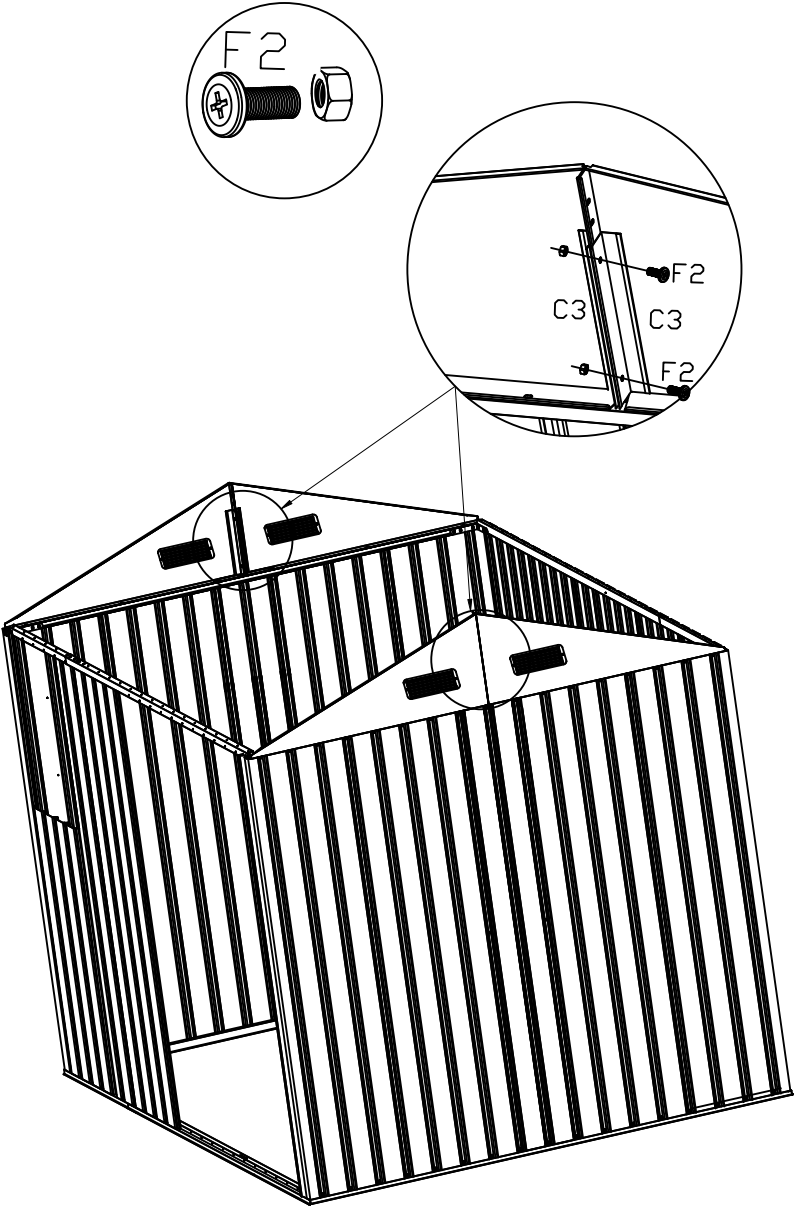



| PART   | NO. | QTY. |
|--|-----|------|
|  | C3  | 4    |
|  | F2  | 4    |



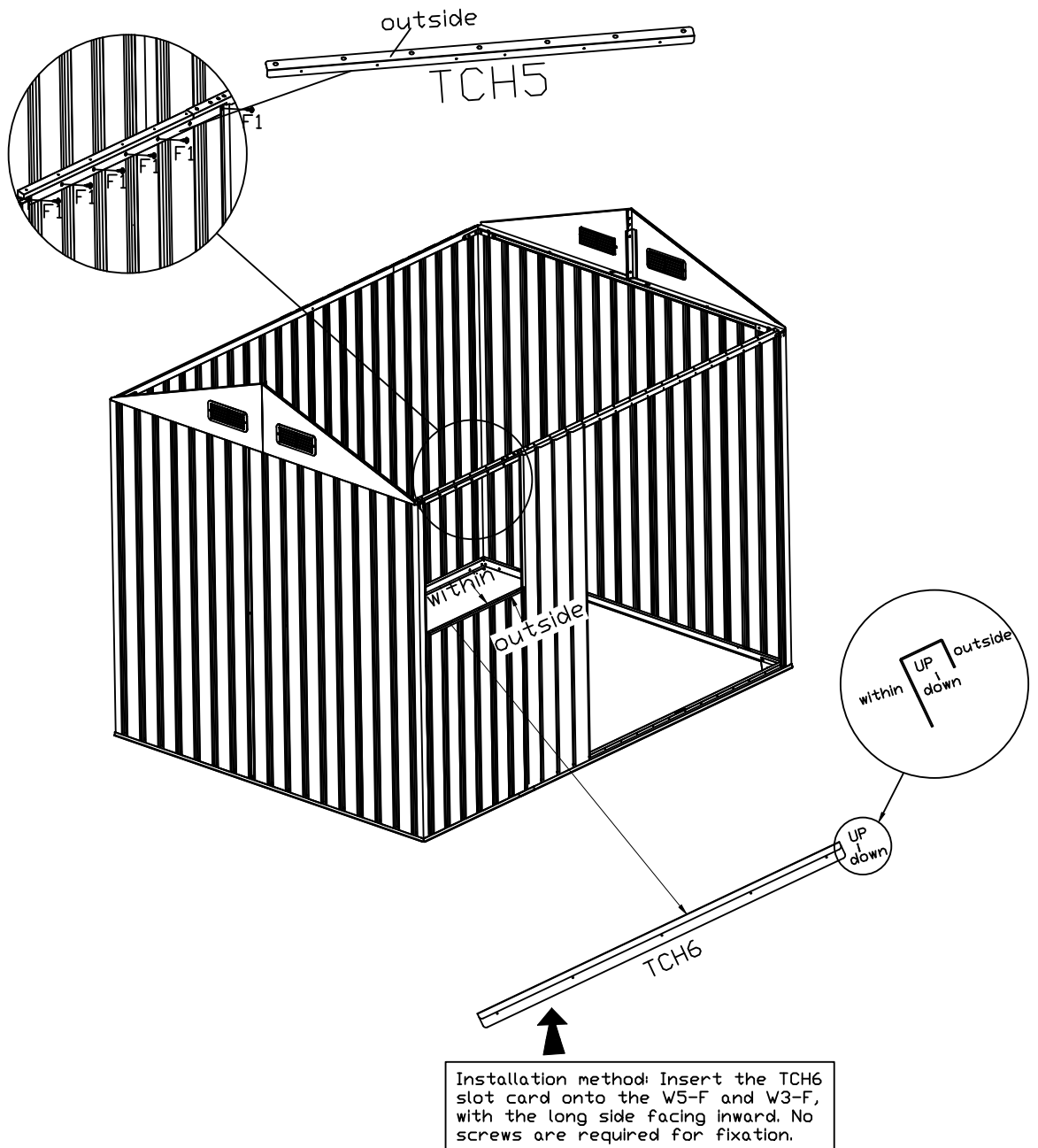



| PART  | NO.  | QTY. |
|---|------|------|
|   | TCH5 | 1    |
|   | TCH6 | 1    |
|  | F1   | 7    |

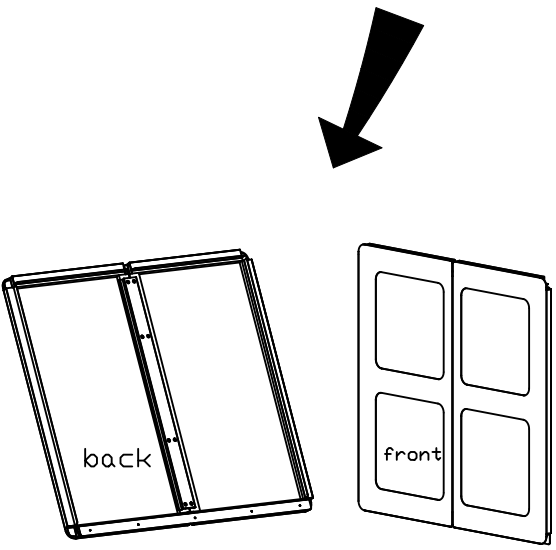
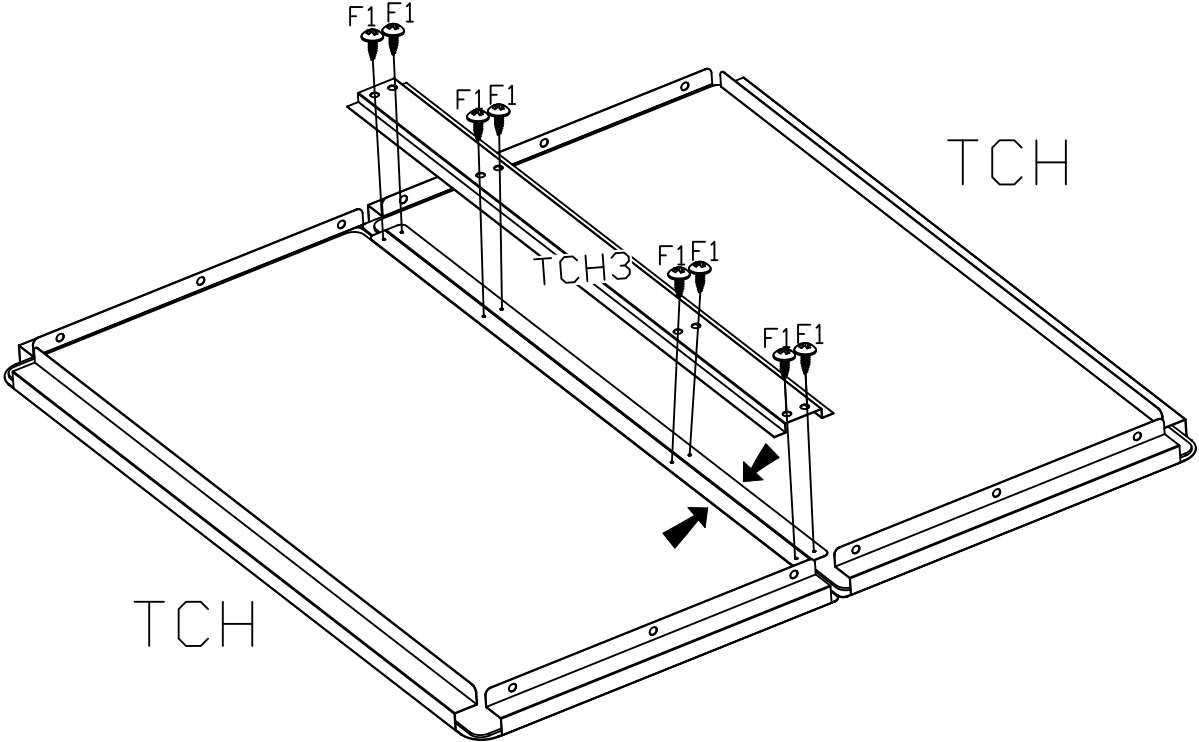

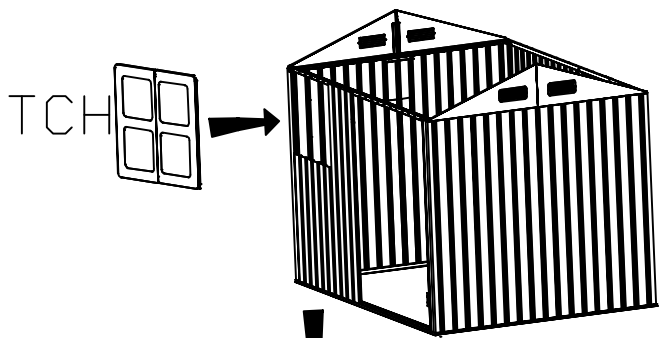
| PART  | NO.  | QTY. |
|---|------|------|
|   | TCH  | 2    |
|   | TCH3 | 1    |
|  | F1   | 8    |





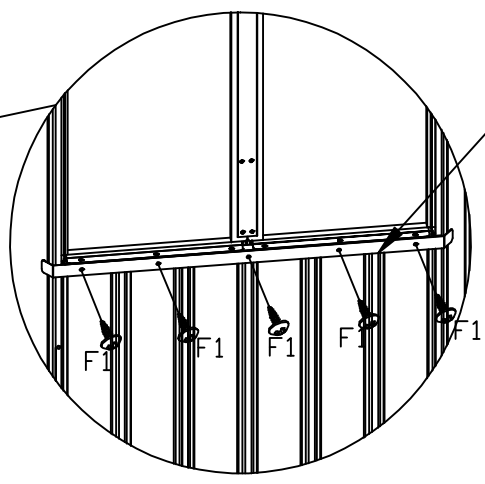
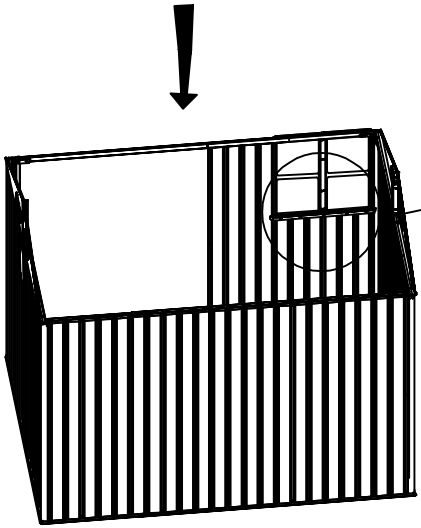
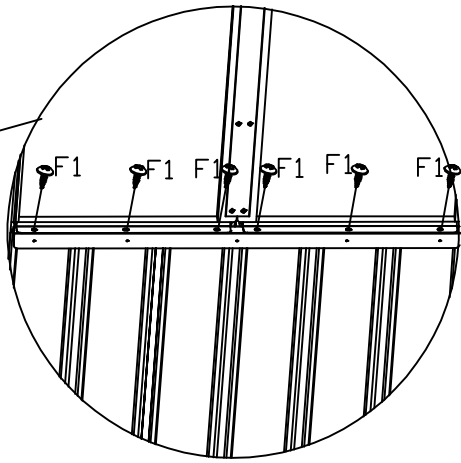
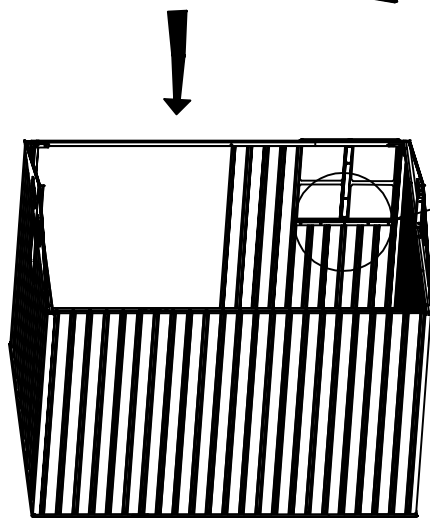
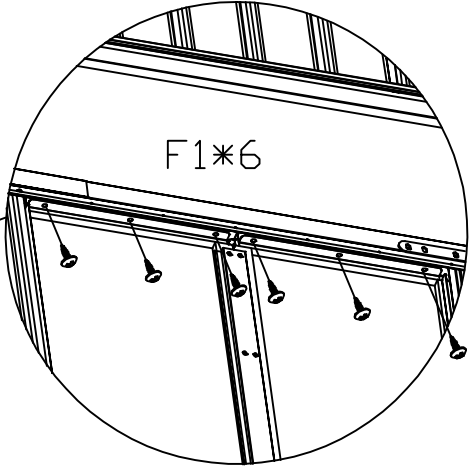
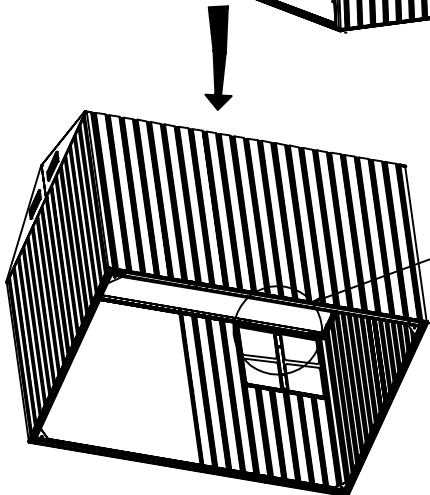

| PART  | NO.  | QTY. |
|---|------|------|
|  | TCH  | 1    |
|  | TCH7 | 1    |
|  | F1   | 17   |



TCH7



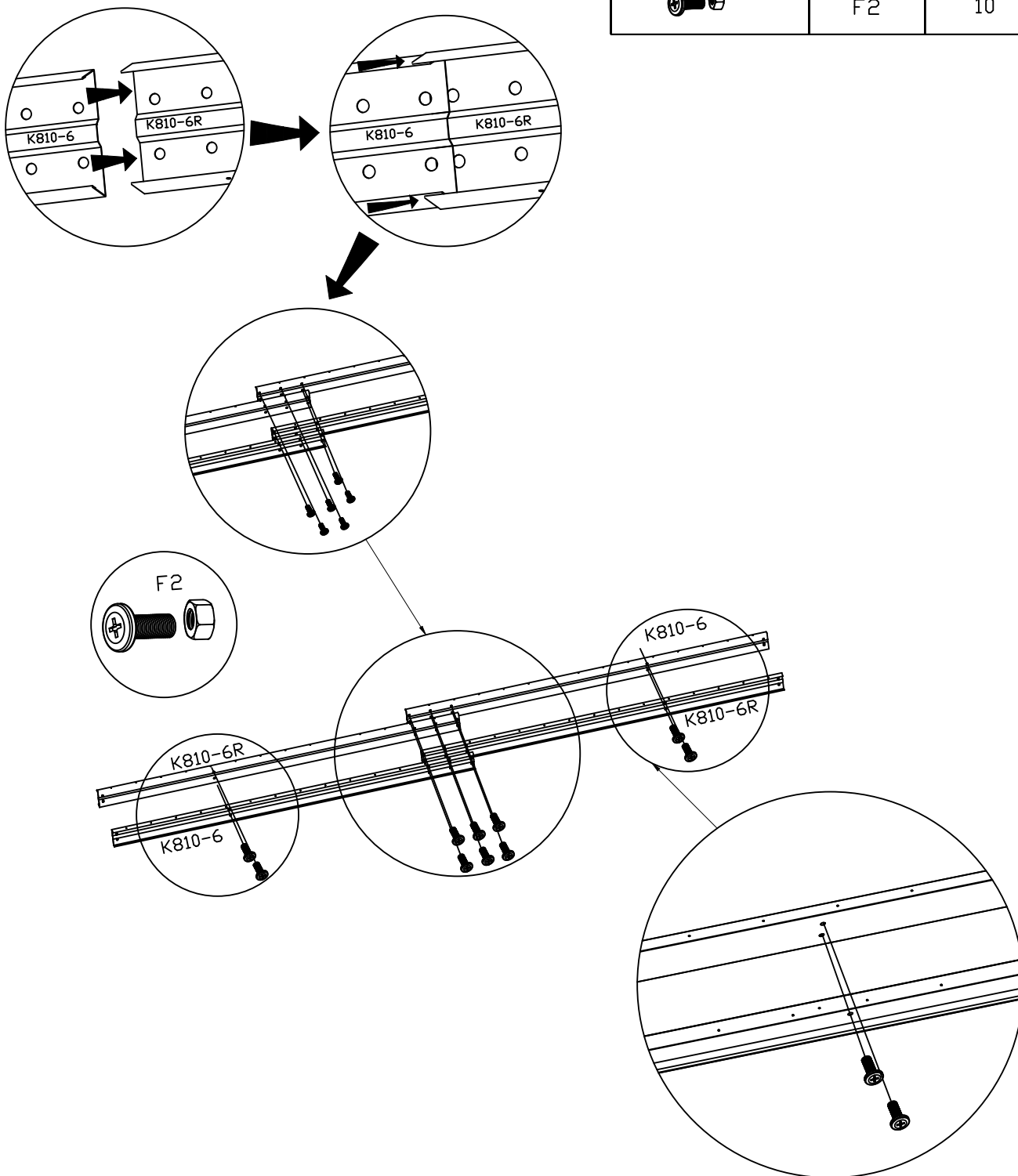

K810-6 is of a smaller width. It can be inserted into K810-6R, and the holes are aligned.

| PART  | NO.     | QTY. |
|---|---------|------|
|   | K810-6  | 2    |
|   | K810-6R | 2    |
|  | F2      | 10   |

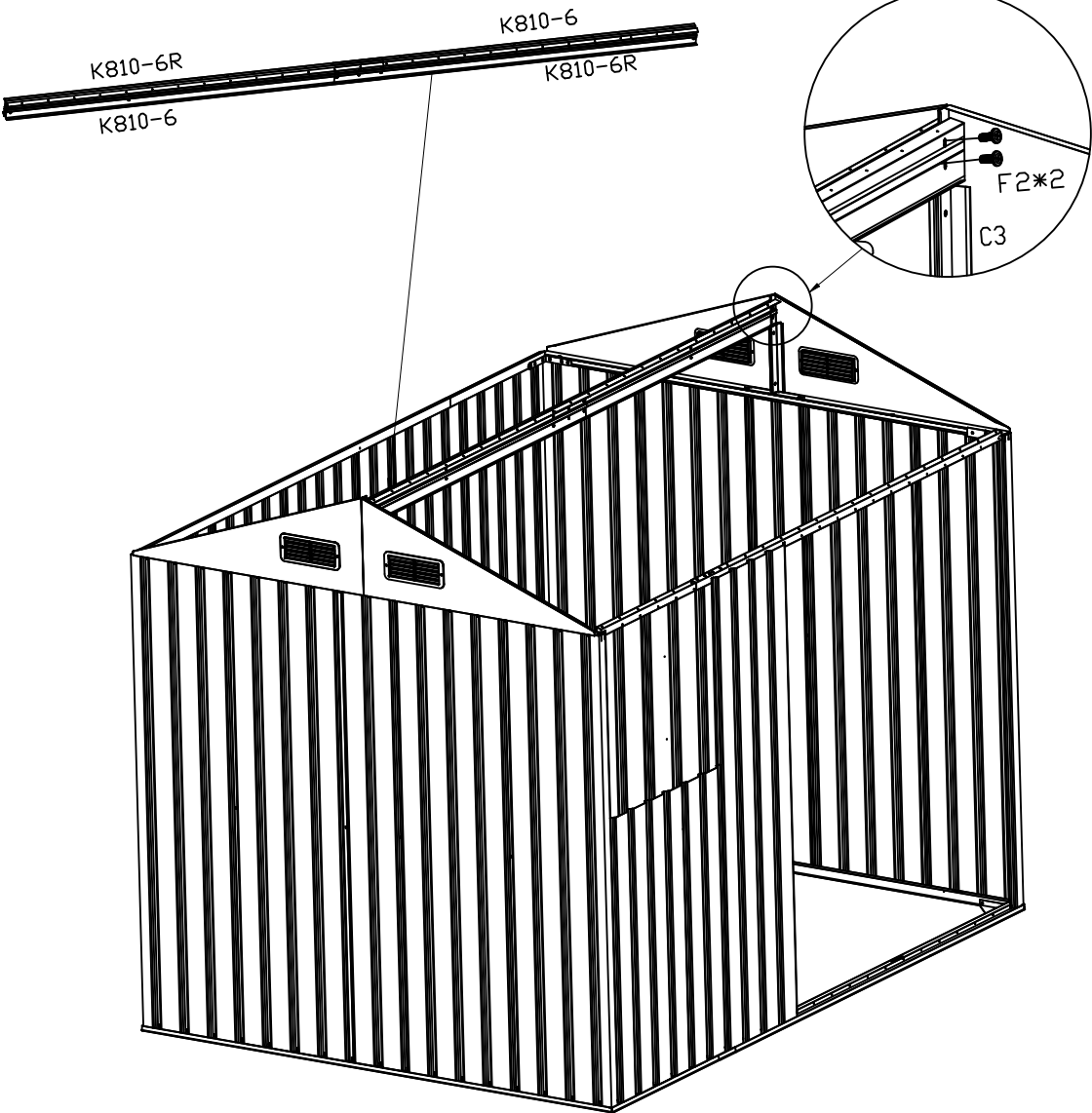





| PART  | NO. | QTY. |
|---|-----|------|
|  | F2  | 4    |

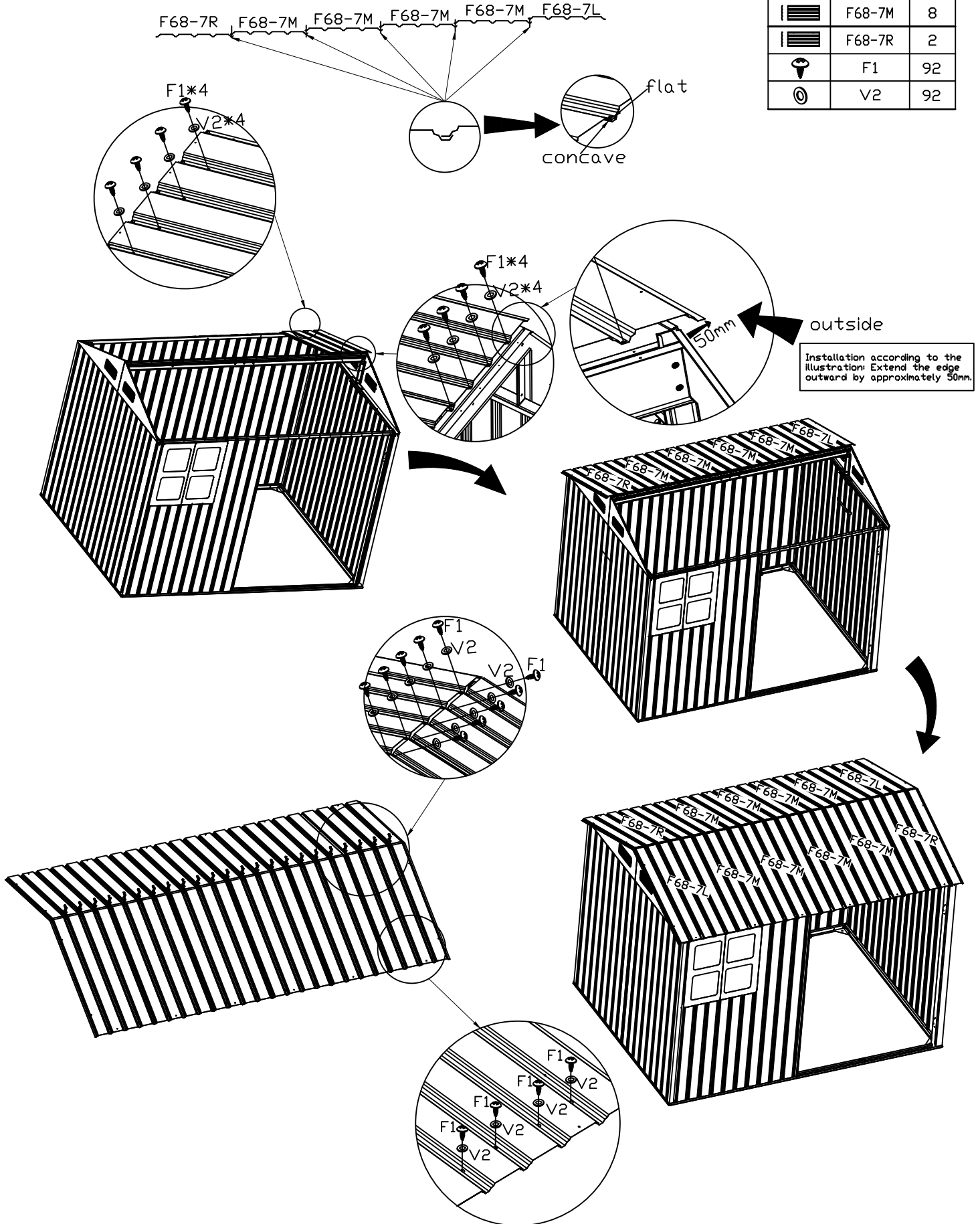

| PART  | NO.    | QTY. |
|---|--------|------|
|  | F68-7L | 2    |
|  | F68-7M | 8    |
|  | F68-7R | 2    |
|  | F1     | 92   |
|  | V2     | 92   |



| PART  | NO.      | QTY. |
|---|----------|------|
|  | K810-10  | 1    |
|  | K810-10R | 1    |
|  | F1       | 4    |
|  | V2       | 4    |

According to the illustration: The two roof rain shields should be connected with F1 self-tapping screws first, and then the subsequent installation can be carried out.

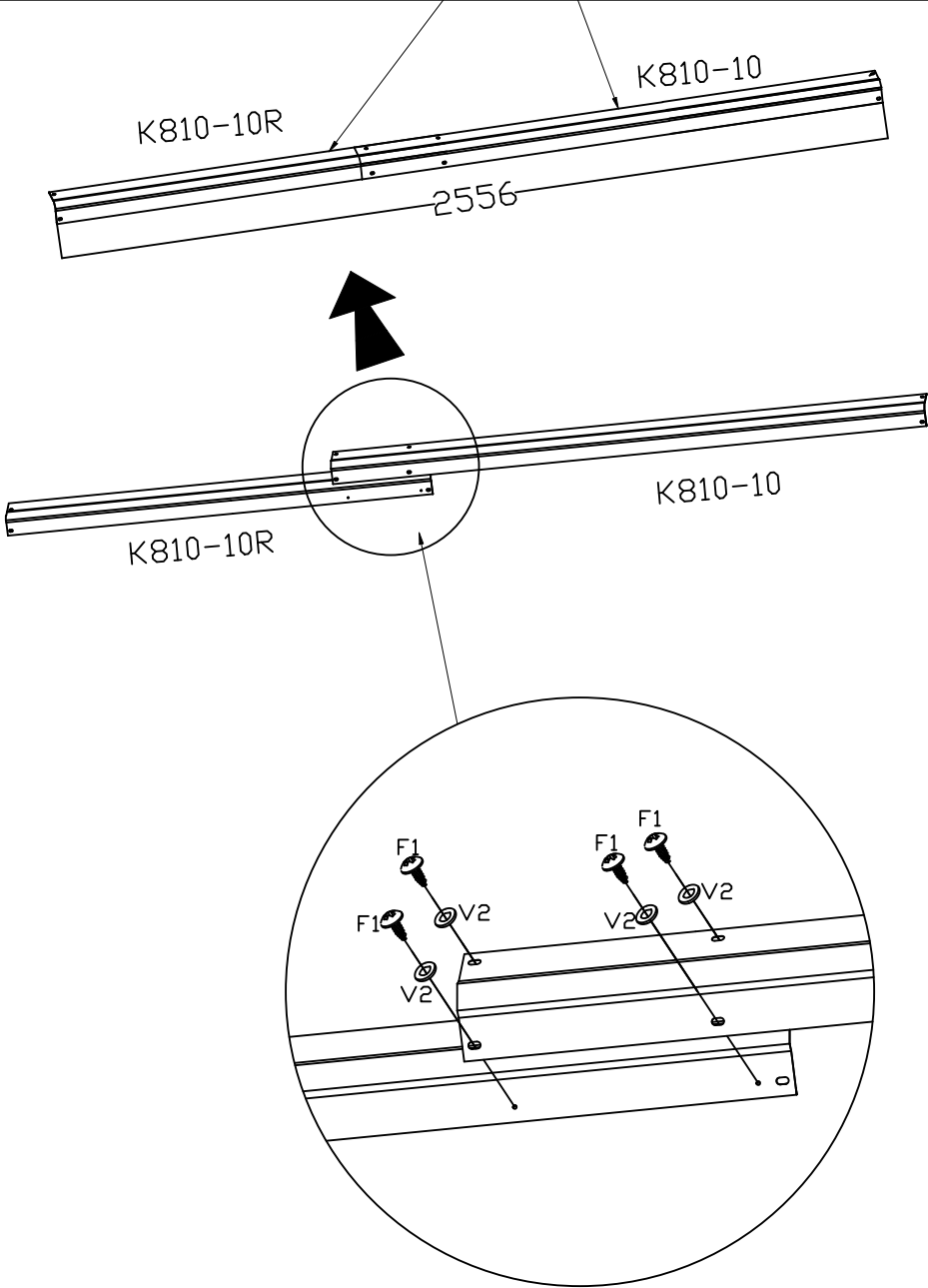

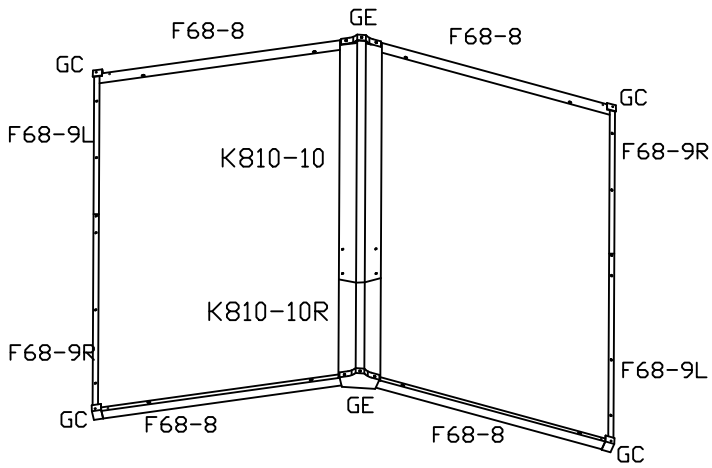

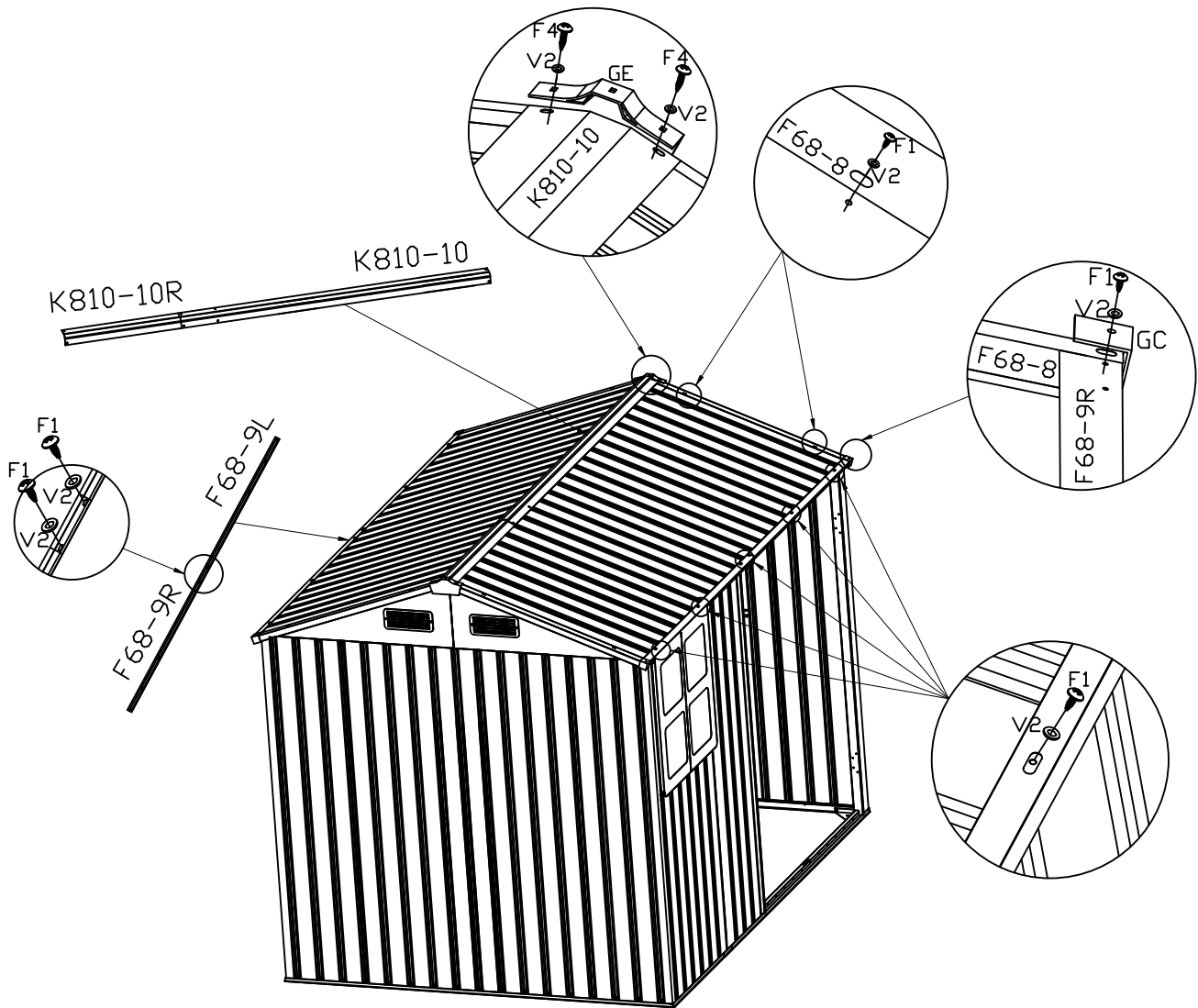

| PART | NO.    | QTY. |
|------|--------|------|
|      | F68-8  | 4    |
|      | F68-9L | 2    |
|      | F68-9R | 2    |
|      | GC     | 4    |
|      | GE     | 2    |
|      | F1     | 24   |
|      | V2     | 28   |
|      | F4     | 4    |



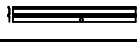

| PART  | NO.   | QTY. |
|---|-------|------|
|  | W5-K  | 1    |
|  | W2-HR | 1    |
|  | F2    | 2    |

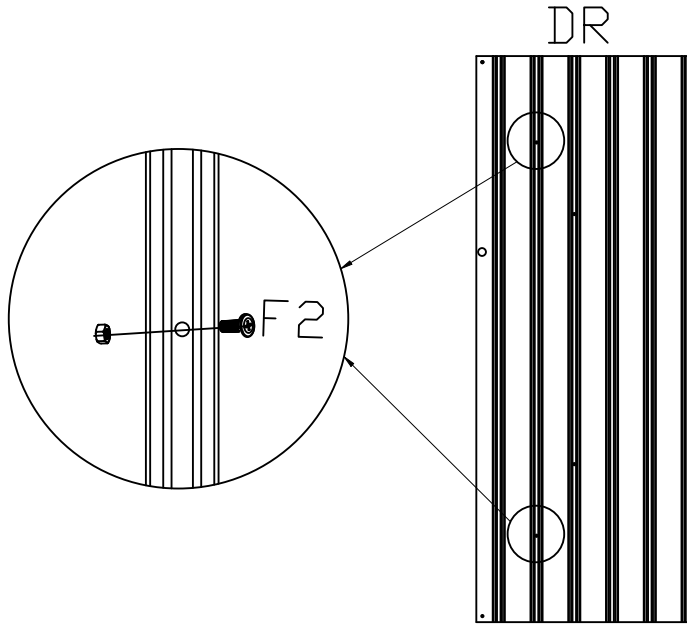



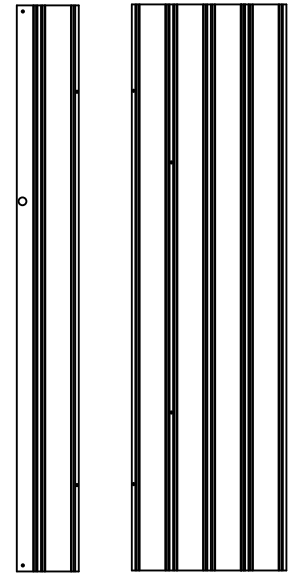

W2-HR W5-K



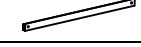
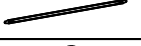

Right door panel assembly



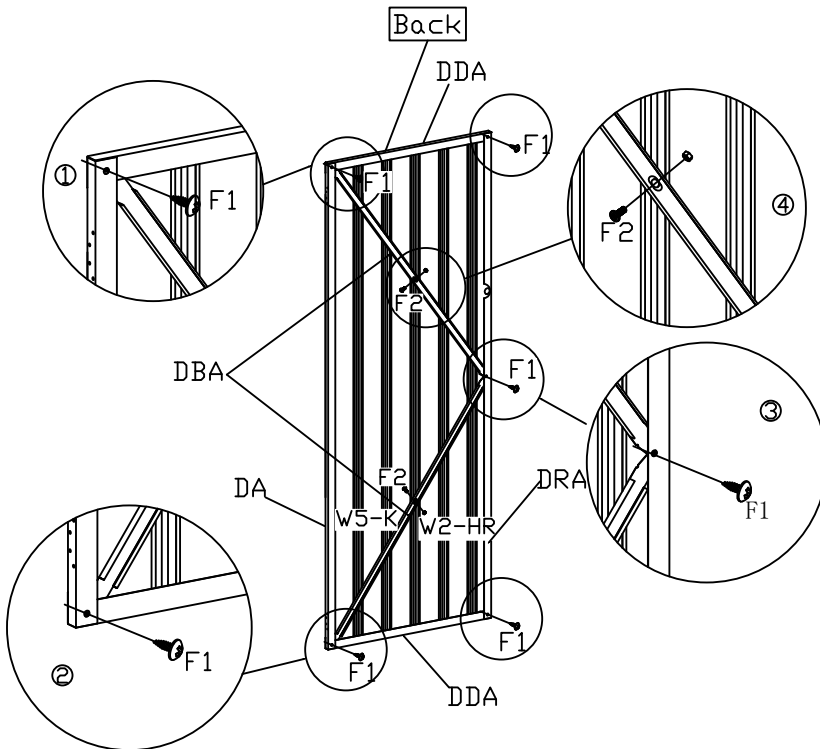

W2-HR W5-K

| PART  | NO. | QTY. |
|---|-----|------|
|  | DA  | 1    |
|  | DRA | 1    |
|  | DDA | 2    |
|  | DBA | 2    |
|  | F1  | 9    |
|  | F2  | 2    |



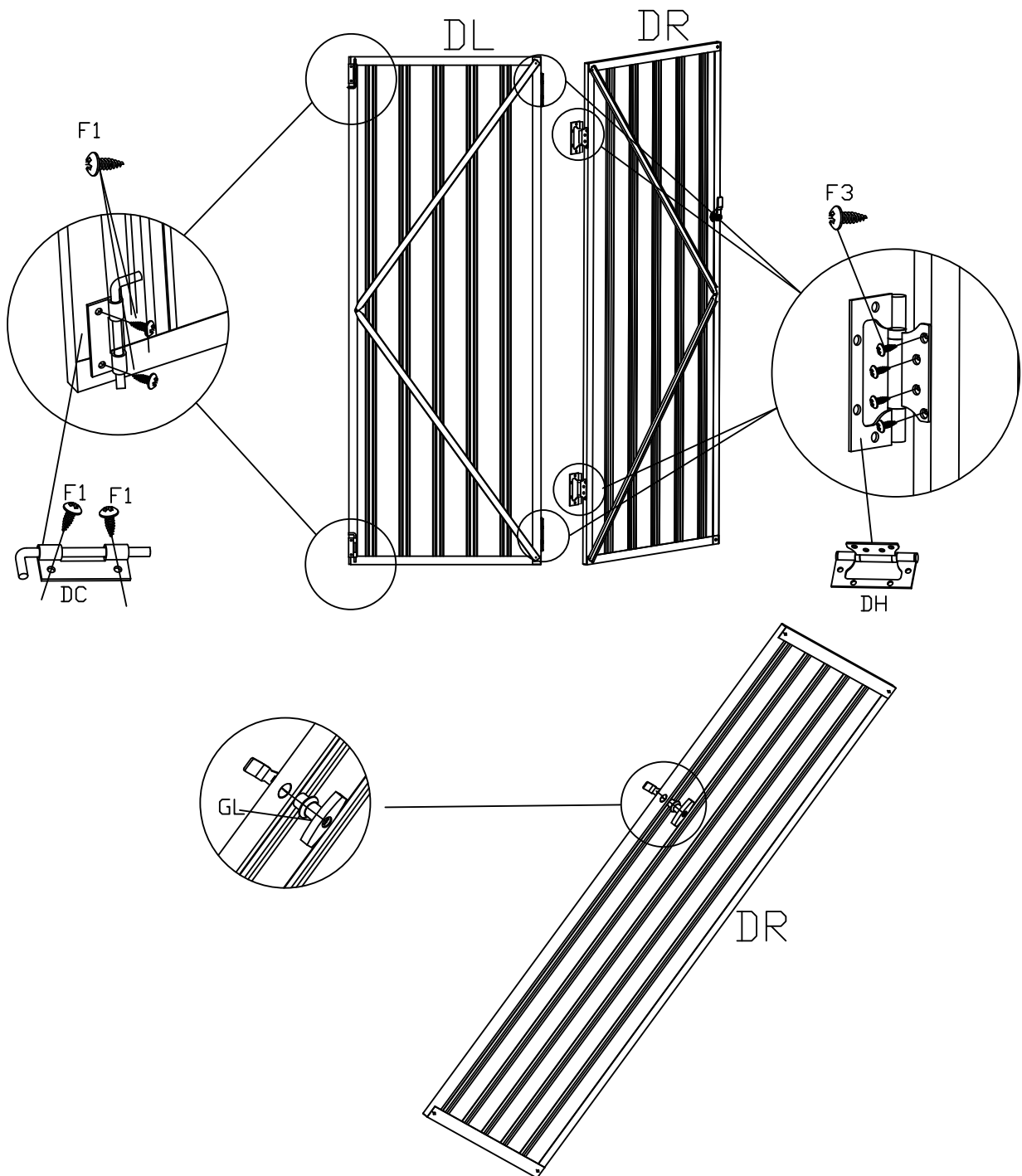

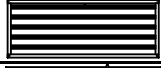
| PART  | NO. | QTY. |
|---|-----|------|
|  | DH  | 4    |
|  | DC  | 2    |
|  | F3  | 16   |
|  | GL  | 1    |
|  | F1  | 4    |



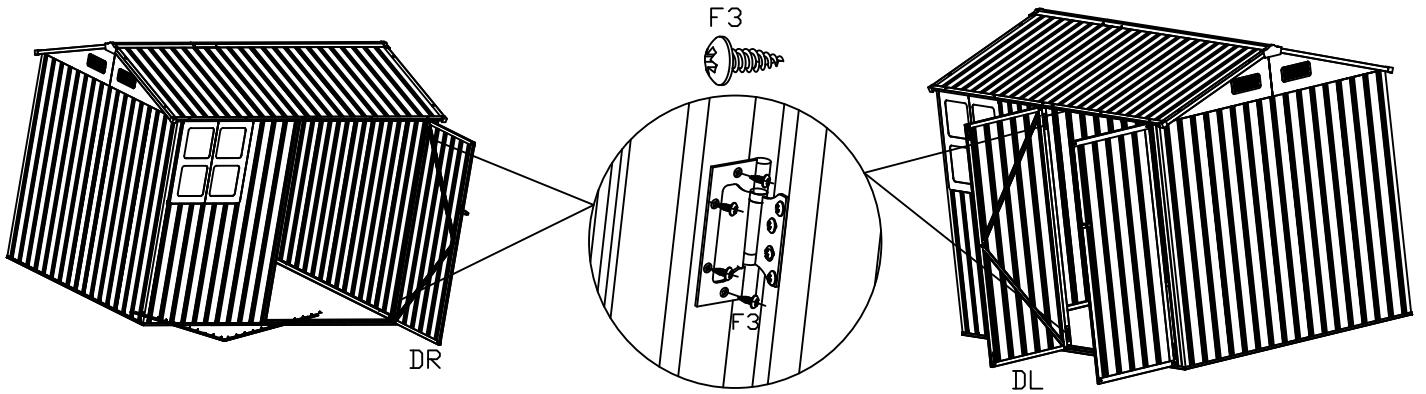

| PART  | NO. | QTY. |
|---|-----|------|
|  | DL  | 1    |
|  | DR  | 1    |
|  | F3  | 16   |

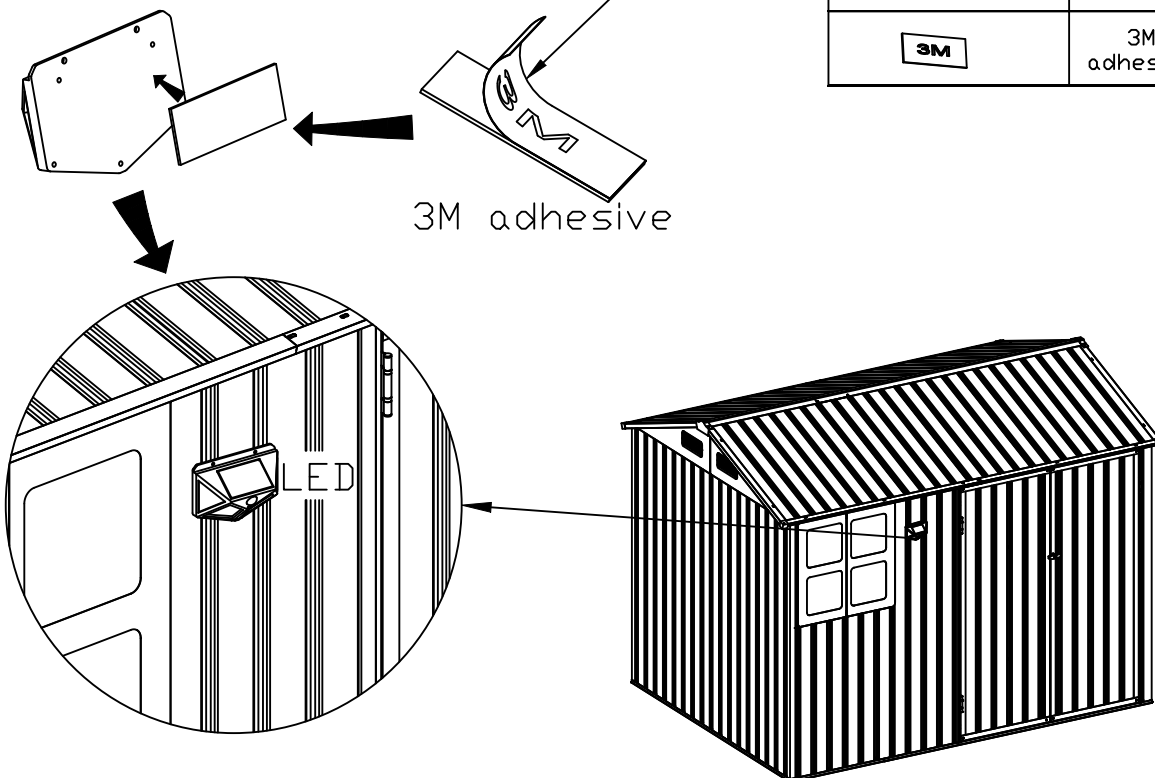

| PART  | NO.         | QTY. |
|---|-------------|------|
|  | LED         | 1    |
|  | 3M adhesive | 1    |

Remove the 3M adhesive sticker and attach the soft magnetic tape to the flat surface on the back of the LED light.



| PART  | NO. | QTY. |
|---|-----|------|
|  | SL  | 46   |

The exposed parts of the upper crossbeam K810-6, K810-6R and the screws for the roof cover assembly need to be covered with plastic protective caps.

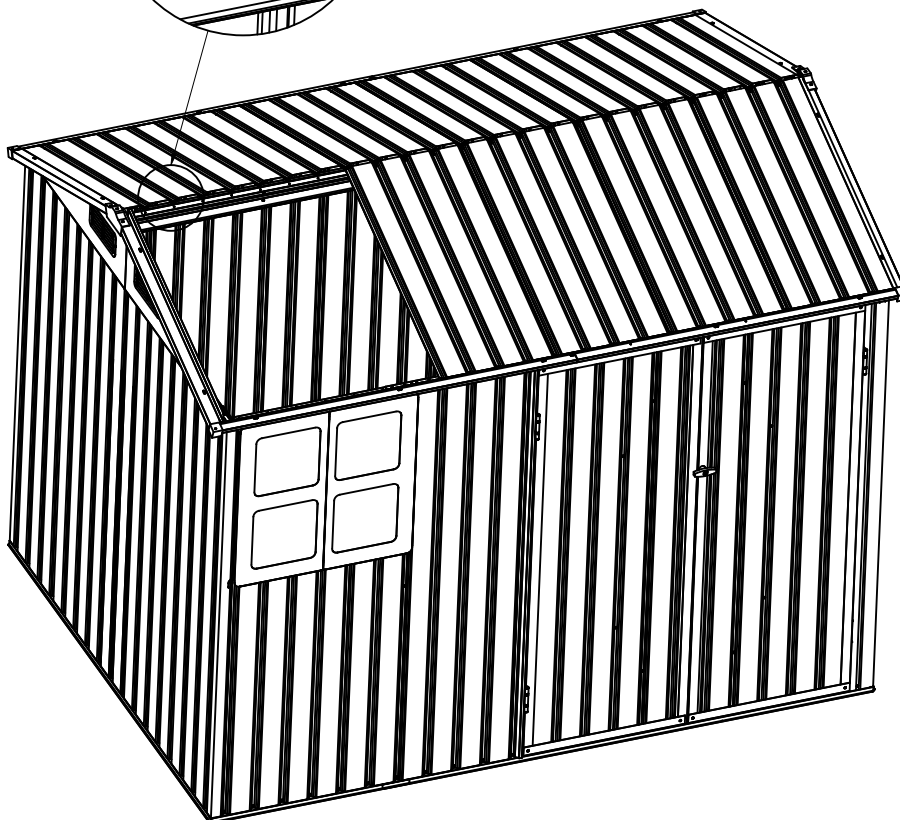
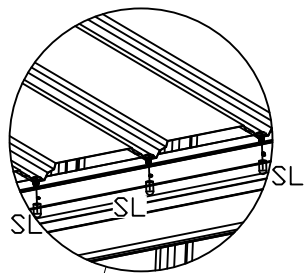

# HELP CENTER

Question about your product? We're here to help. Visit us at:

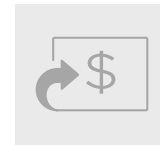
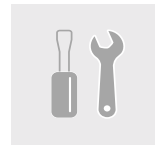
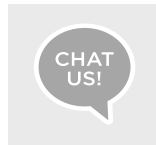

[Chat Support](#)

[Product Inquiry](#)

[Orders FAQ](#)

[Product Assembly](#)

[Returns & Refunds](#)

## We Stand Behind the Quality of Their Furniture

If you have any issues with your item please let us know! We will always do our best to come up with a solution that you will be happy with. Please get in touch with our customer service team before returning the product. And pls do not throw the original box(es) if you have not finished assembling or confirmed no quality issues.

Length of return period:

Items can be returned within 30 days of purchase.

In the meanwhile, everything you purchased from us comes with a one-year warranty.

Who is responsible for the return shipping fee:

We will cover the return shipping fees if:

1. Your item has a manufacturing defect in its materials or workmanship. For example, torn wicker or misaligned screw holes. We will send you a prepaid shipping label after photos are sent.
2. Your item has been damaged in transit. For example, glass is broken or wicker is damaged. We will send you a prepaid shipping label after photos are sent.
3. You receive the wrong box(es) due to a warehouse error. We will send you a prepaid shipping label after photos are sent of the wrong SKU numbers on the outer box(es).
4. One or more boxes are lost in transit. We will send you a prepaid shipping label if you no longer want the item.

\*However, we still hope to work with you for a better solution instead of a return. Please don't hesitate to contact our customer service team.

Customer will cover the return shipping fees if:

1. You don't like the product(s) after receiving the box(es).
2. You no longer need the product(s) but you have received the box(es).
3. You buy the product(s) by mistake but you have received the box(es).
4. Order/Shipment cancellation failed and you have received the box(es).

---

## Return Request

In order to get a full refund as described in this return policy, all items must be: (1) In a brand new/unused condition, please provide photos before and after packaging. (2) When returning, all accessories and parts are firmly packed in all original packaging.

If your return does not meet the requirements, you may not get a full refund.

When will I be refunded?

The refund is released once the goods have been returned to our warehouse.

What if the product is damaged/defective outside of the valid return period?

We want you to be a happy customer. Please reach out to us by email and we will come up with a solution to make sure you are satisfied.

## Reach us at

 [support@garvee.com](mailto:support@garvee.com)