

ASSEMBLY INSTRUCTIONS



Item No : D1651-16B OSCAR COUNTER TABLE FOR GLASS CTR TABLE







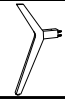



D1651-15T OSCAR ROUND GLASS TOP FOR STD OR COUNTER DINING BASE

Thank you for purchasing this quality product. Be sure to check all packing materials carefully for small parts, which may have come loose inside the carton during shipment. Identify and count all items and compare with the parts list and/or hardware list shown below.

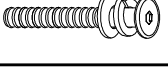
IMPORTANT NOTE :

- * PLACE ALL WOODEN PARTS ON A CLEAN AND SMOOTH SURFACE SUCH AS A RUG OR CARPET TO AVOID THE PARTS FROM BEING SCRATCHED.
- * PLEASE DO NOT OVERTIGHTEN THE SCREWS TO AVOID CRACKING THE PARTS.
- * BEFORE YOU BEGIN, KINDLY REVIEW THE ASSEMBLY INSTRUCTIONS AND FOLLOW STEP BY STEP.
- * KEEP ALL HARDWARE PARTS OUT OF REACH OF CHILDREN.

PARTS LIST			
NO	DESCRIPTION	SKETCH	QTY
A	Glass Top		1 Pc
B	Leg		4 Pcs
C	Shelf		1 Pc
D	Mounting Box		1 Pc

HARDWARE LIST			
NO	DESCRIPTION	SKETCH	QTY
1	Hex Nut 5/16"		8 Pcs
2	Spring Washer 5/16"		8 Pcs
3	Flat Washer 5/16"		8 Pcs
4	Wrench		1 Pc
5	JCBC Bolt M6 x 2 6/8" w/ Spring Washer M6 and Flat Washer M6 x 4/8"		4 Pcs
6	Allen Key M4		1 Pc
7	JCBC Bolt M6 x 1"		4 Pcs
8	Allen Key M3		1 Pc
9	Threaded Rod		8 Pcs
10	Aluminium Die		4 Pcs

STEP 1 : Remove the plastic bolt cover on each table leg (B) before assembling the table. Attach the table leg (B) to the mounting box (D) by insert the bolts on the legs into the respective holes on the box and assemble the table legs (B) to the mounting box (D) by using the Wrench (4) with hardware 1, 2, and 3.

***DO NOT TIGHTEN THE NUTS.**

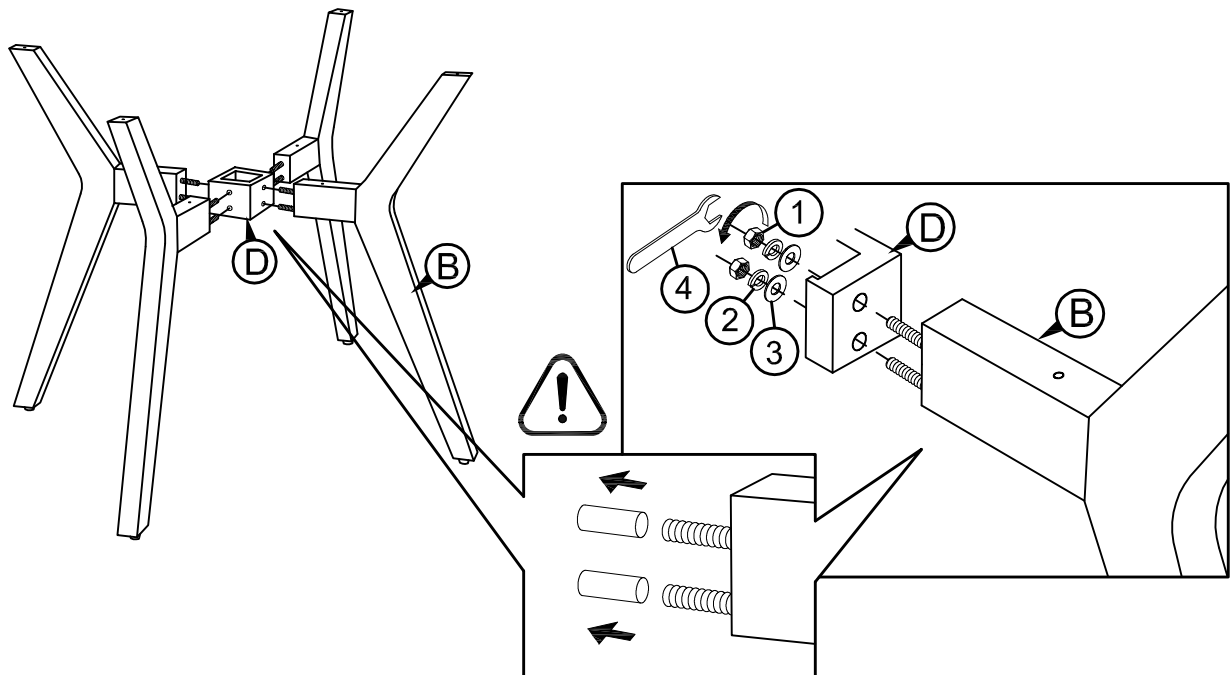

STEP 2 : Face the larger hole of the Aluminium die (10) upward and align the hole on the die to the screw hole on the top of leg (B). Assemble the Aluminium die (10) with the leg (B) by using the Allen Key (6) with hardware 7.
***PLEASE FULLY TIGHTEN THE BOLT.**

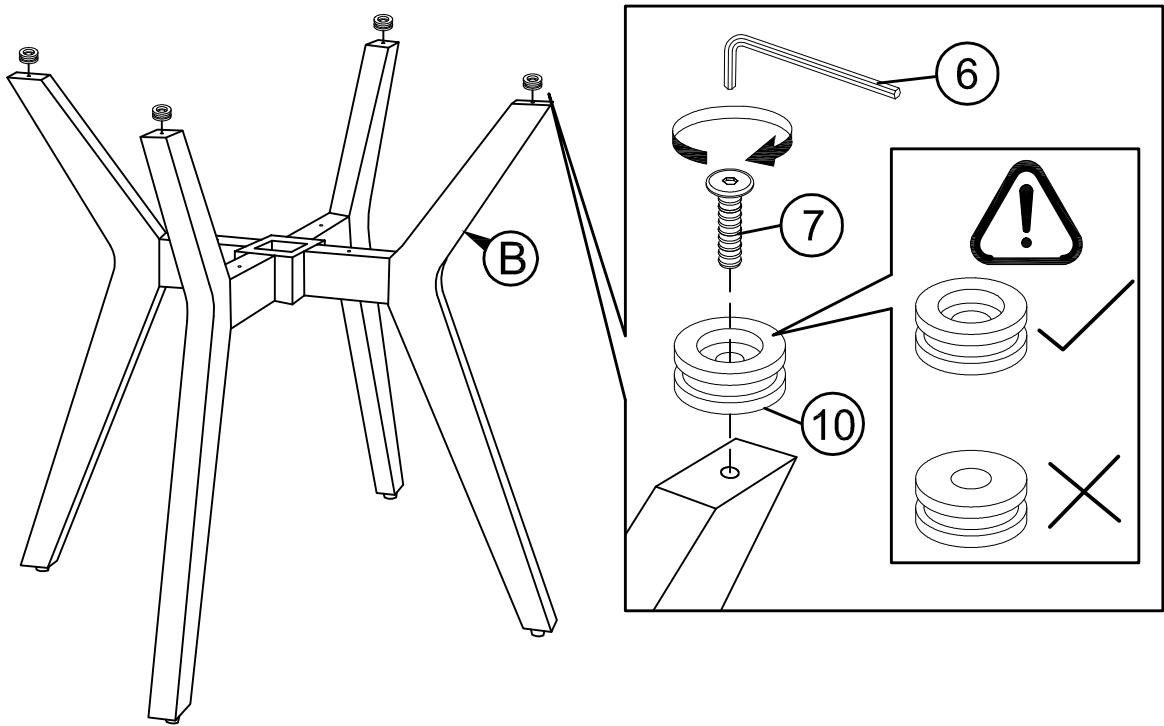

STEP 3 : Place the glass top (A) on the table base by aligning the Aluminium die (10) on the table base with the pre-installed die cap on the glass top (A).

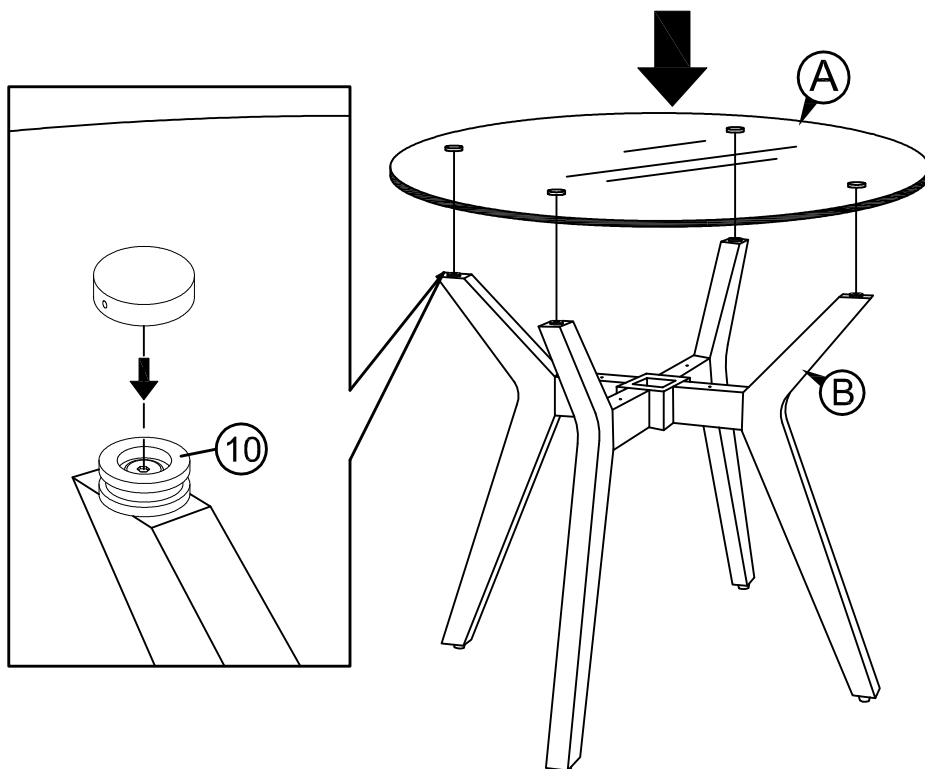

STEP 4 : Fully tighten all the Hex nuts of the table leg (B) with the mounting box (D) by using the Wrench (4).

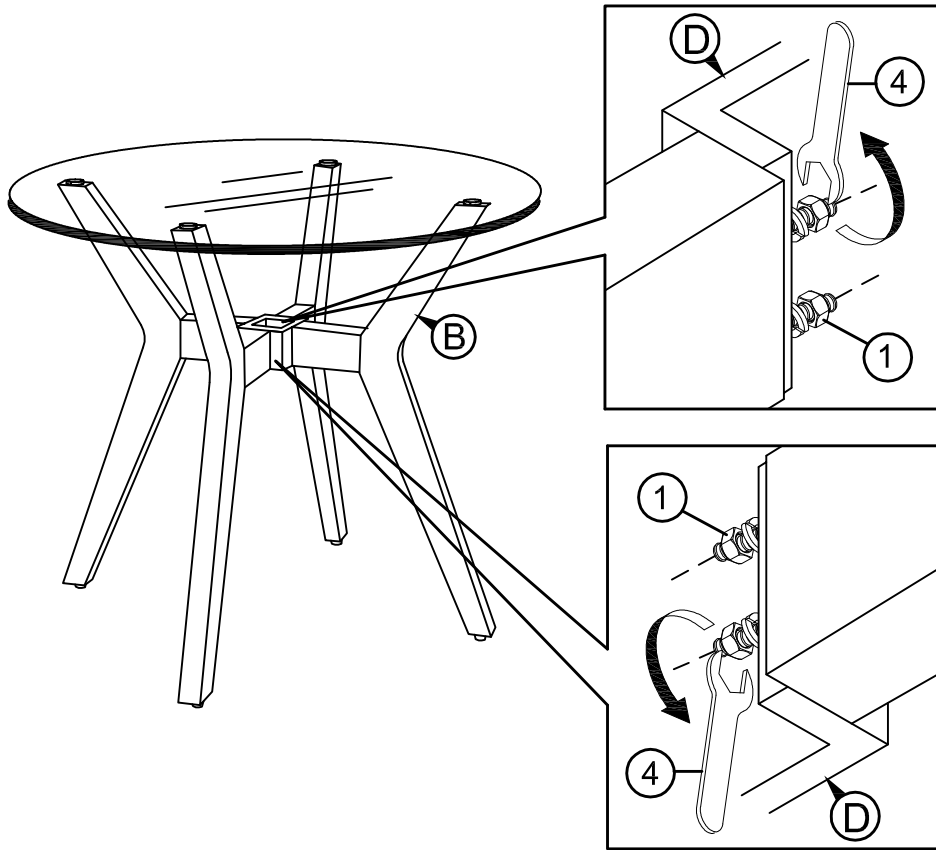

STEP 5 : Place the Shelf (C) on top of the mounting box (D) and assemble the Shelf (C) with the table leg (B) by using the Allen Key (6) with hardware 5.

***TIGHTEN THE BOLTS.**

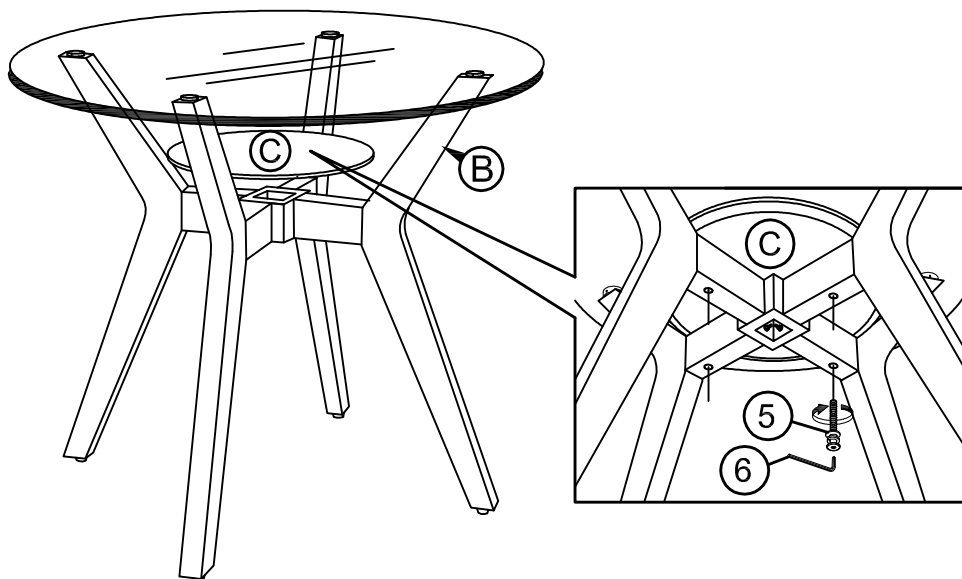

STEP 6 : Assemble the glass top (A) with the table base by using the Allen Key (8) with hardware 9.
*Attention: Make sure the hex hole on the threaded rod is facing outward to enable the Allen key to turn the rod.

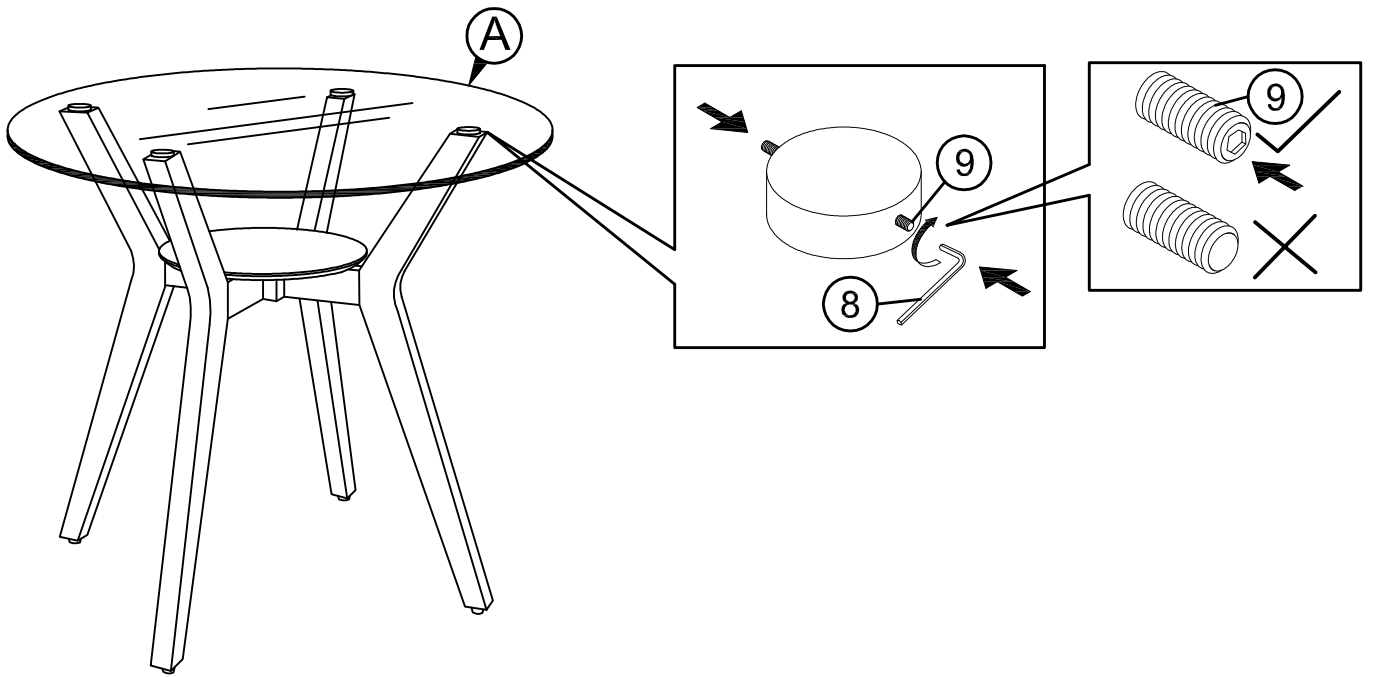

STEP 7 : To level the table, place the table on a flat surface and adjust the levelers on the bottom of each leg (B).

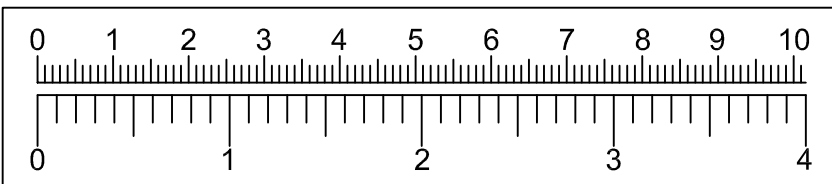
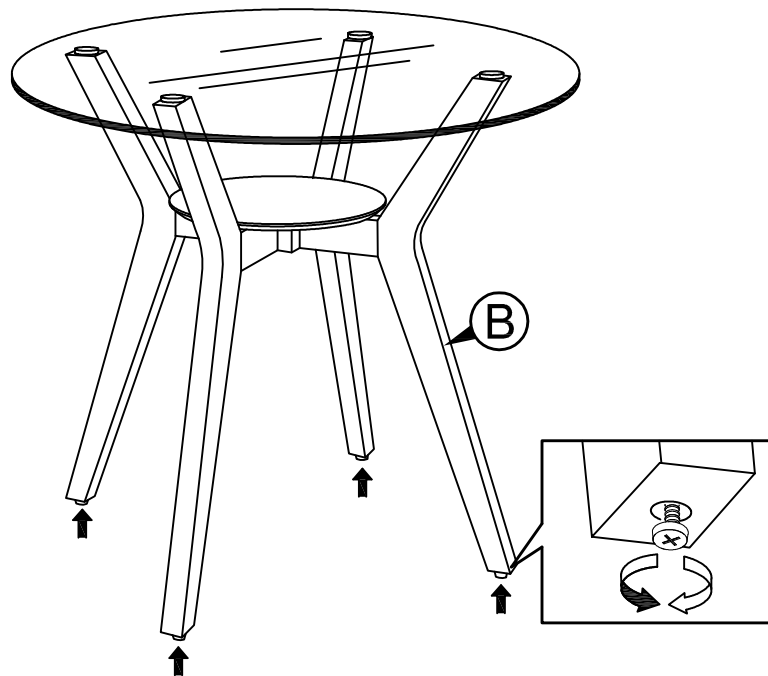





ASSEMBLY INSTRUCTIONS





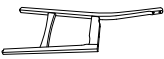
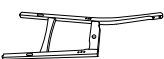



Item No : D1651-22
Oscar Counter Chair
(2PCS PER CARTON)

Thank you for purchasing this quality product. Be sure to check all packing materials carefully for small parts, which may have come loose inside the carton during shipment. Identify and count all items and compare with the parts list and/or hardware list shown below.

IMPORTANT NOTE :

- * PLACE ALL WOODEN PARTS ON A CLEAN AND SMOOTH SURFACE SUCH AS A RUG OR CARPET TO AVOID THE PARTS FROM BEING SCRATCHED.
- * PLEASE DO NOT OVERTIGHTEN THE SCREWS TO AVOID CRACKING THE PARTS.
- * BEFORE YOU BEGIN, KINDLY REVIEW THE ASSEMBLY INSTRUCTIONS AND FOLLOW STEP BY STEP.
- * KEEP ALL HARDWARE PARTS OUT OF REACH OF CHILDREN.

PARTS LIST			
NO	DESCRIPTION	SKETCH	QTY
A	Stretcher		4 Pcs
B	Left Side Facing (LSF) Frame (L)		2 Pcs
C	Right Side Facing (RSF) Frame (R)		2 Pcs
D	Rail		4 Pcs
E	Chair Back		2 Pcs
F	Cushion Seat		2 Pcs

HARDWARE LIST			
NO	DESCRIPTION	SKETCH	QTY
1	JCBC Bolt M6 x 1" w/ Spring Washer M6 and Flat Washer M6 x 4/8"		8 Pcs
2	JCBC Bolt M6 x 1 6/8" w/ Spring Washer M6 and Flat Washer M6 x 4/8"		8 Pcs
3	Allen Key M4		1 Pc
4	L Bracket		8 Pcs
5	PH CB Screw M4 x 4/8"		16 Pcs
6	Wood Dowel M8 x 1"		4 Pcs
7	PH CB Screw M4 x 1 4/8"		8 Pcs
8	Wood Button 9/16"		8 Pcs

STEP 1 : Install Stretcher (A) and Rails (D) between LSF Frame (B) and RSF Frame (C) by align the pieces into the designated holes of the frames.

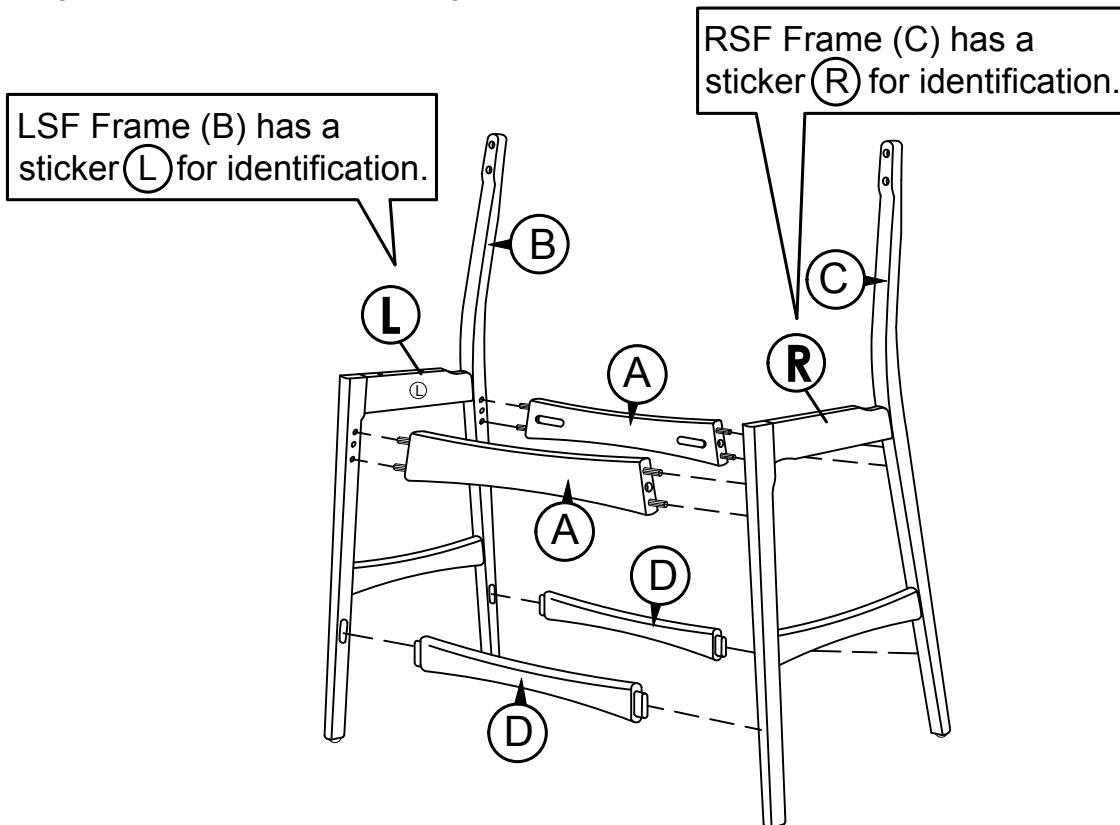

STEP 2 : Assemble only the Stretcher (A) to the LSF and RSF Frame (B & C) by using Allen Key (3) with the hardware (2).

*DO NOT FULLY TIGHTEN THE BOLTS OR INSTALL ANY SCREWS ON THE RAILS (D)

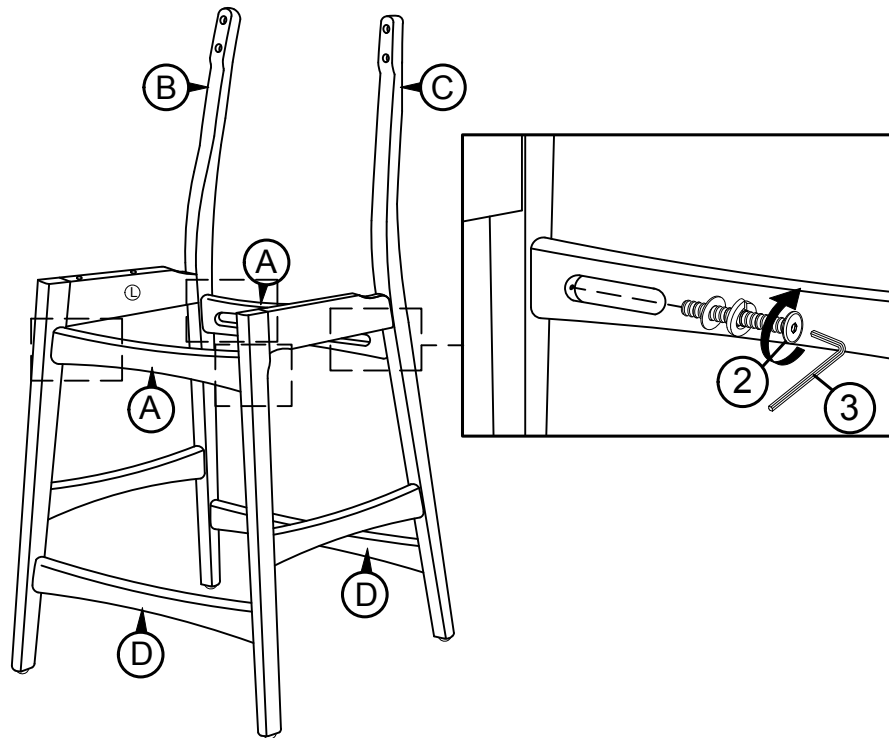

STEP 3 : Assemble the Chair Back (E) to the top of the assembled chair frame by using the Allen Key (3) with the hardware (1).

*DO NOT OVERTIGHTEN THE BOLTS

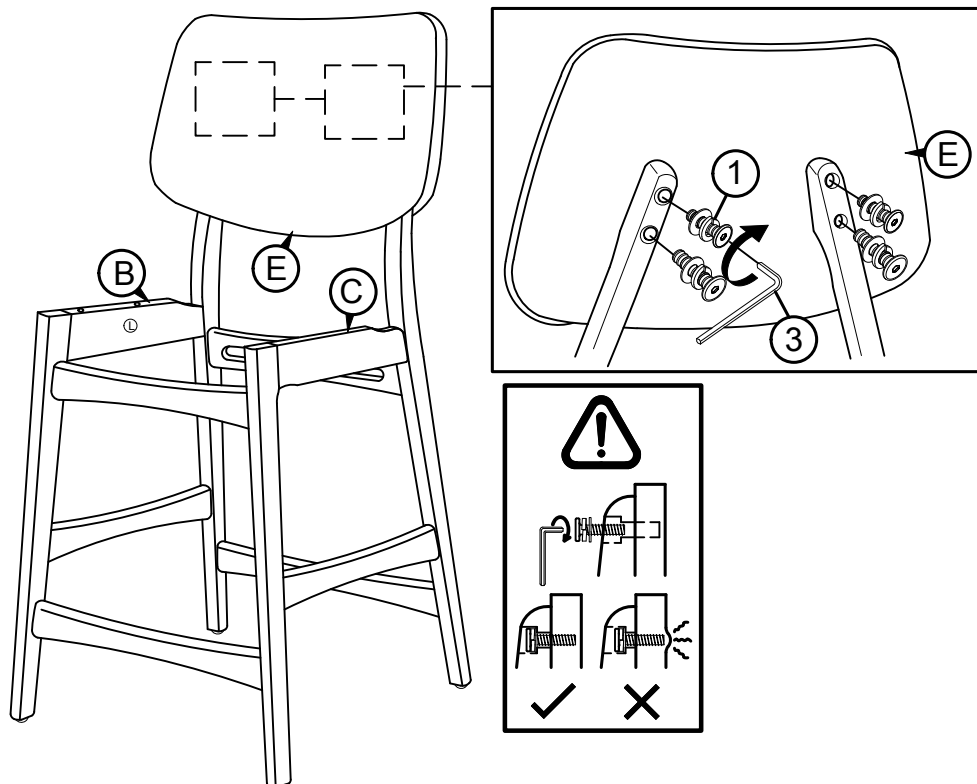

STEP 4 : To conceal the screw holes on the back of the chair frames (B & C), install the Wood Button (8) by using a wood mallet and lightly tap into each screw hole.

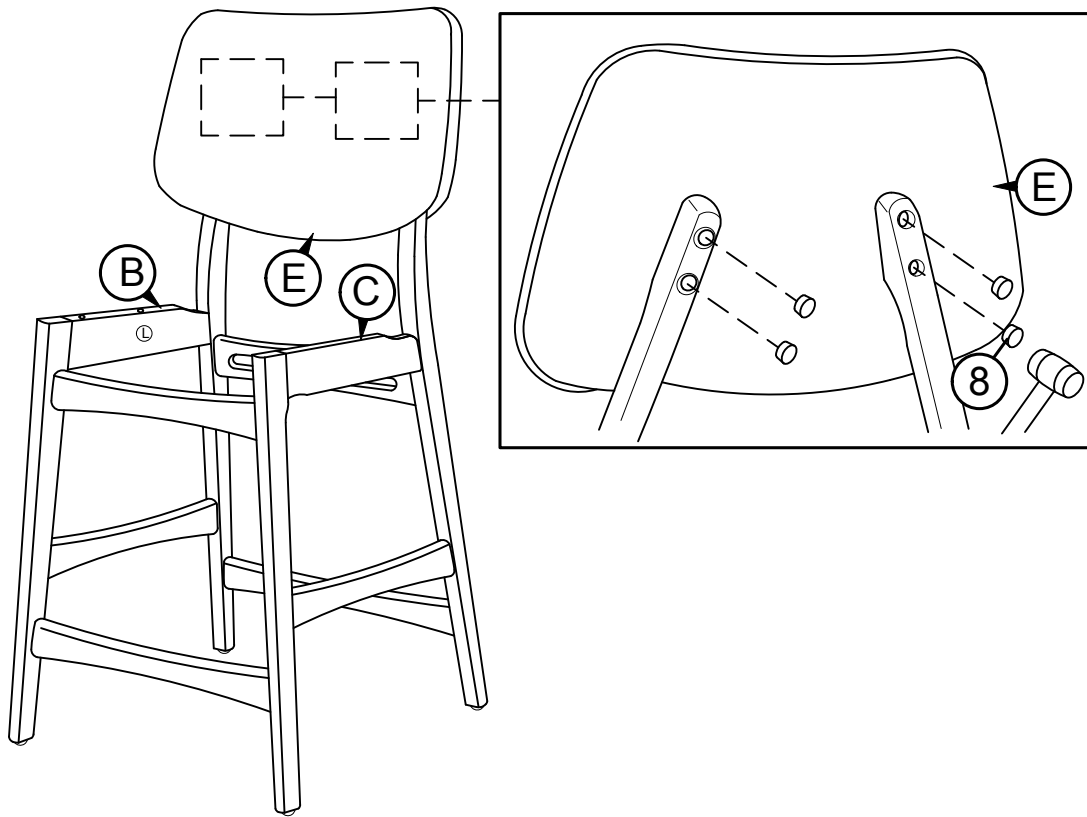

STEP 5 : To level the chair, place the chair on a flat surface and tighten all the bolts using Allen Key (3).

***DO NOT OVERTIGHTEN THE BOLTS**

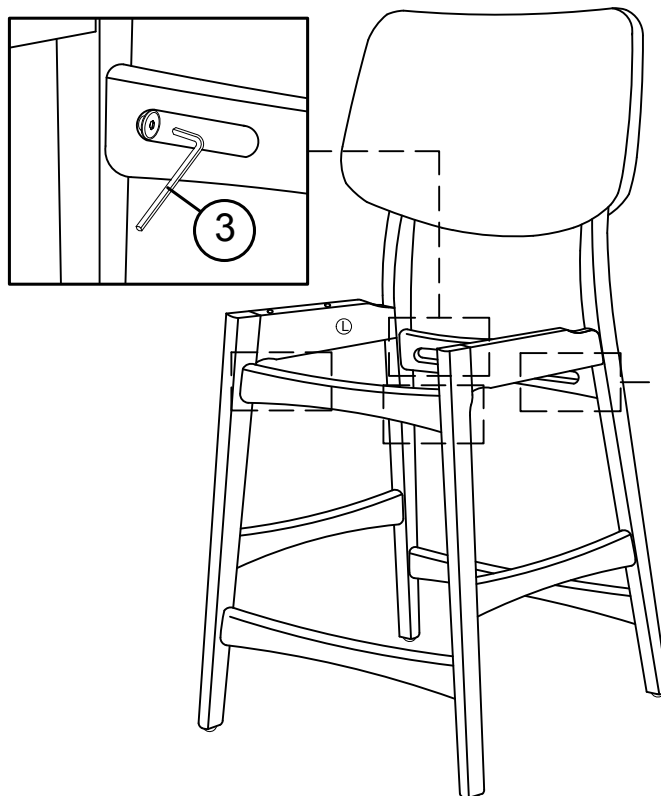

STEP 6 : Insert Wood Dowel (6) into the designated hole on LSF Frame (B).

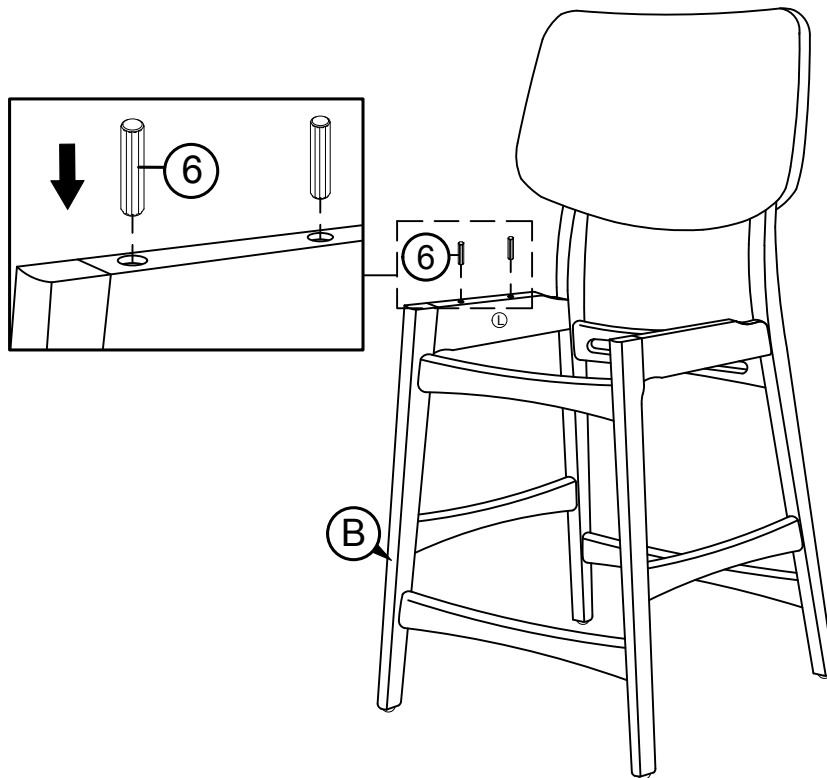

STEP 7 : Place the Cushion Seat (F) upside down on a elevated surface (ex. Table top). Then, place the chair frame upside down and push the wood dowels (6) on the LSF Frame (B) into the holes on the bottom Cushion Seat (F). Tighten the Rails (D) to the chair frames (B & C) by using a screwdriver with hardware (7).

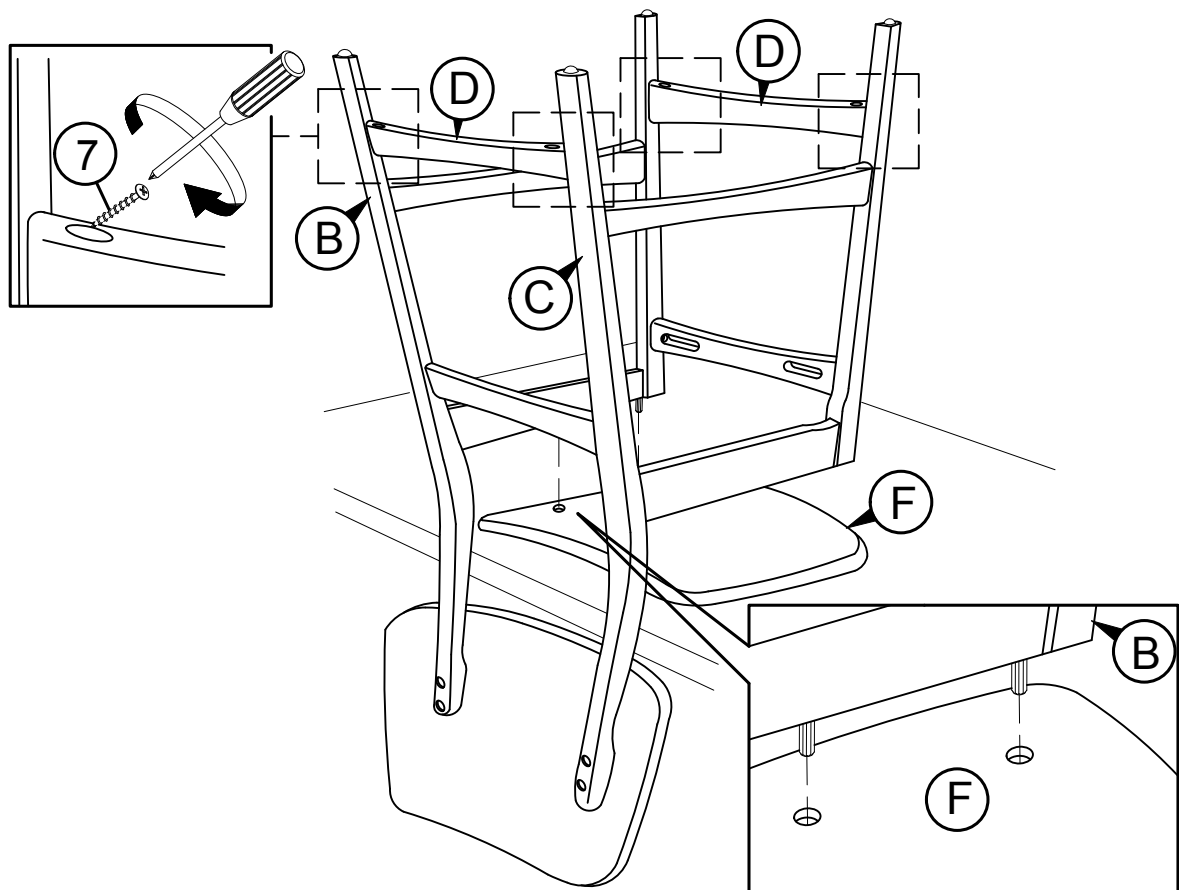

STEP 8 : Assemble the chair frames (B&C) to the Cushion Seat (F) by using a screwdriver with hardware (4) & (5).

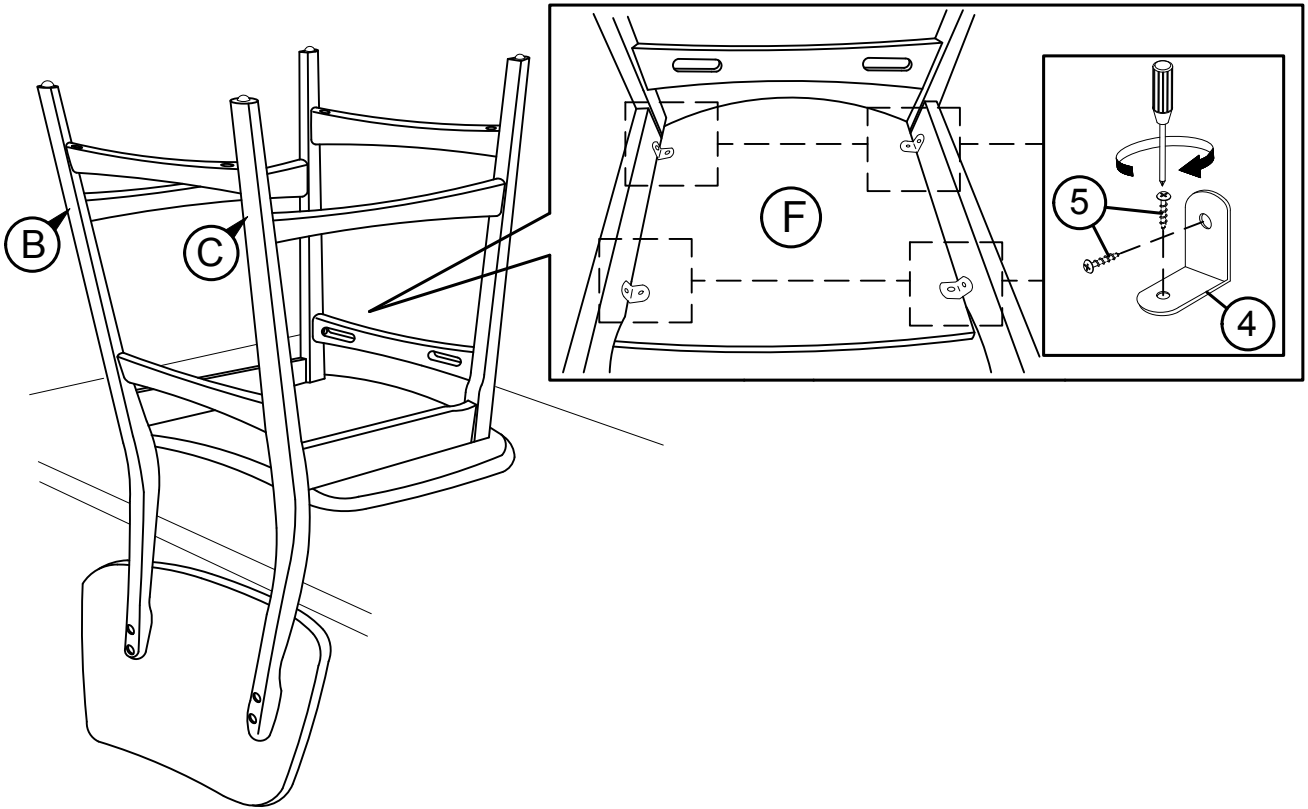

STEP 9 : Place the chair right side up and the assembly is complete.

