

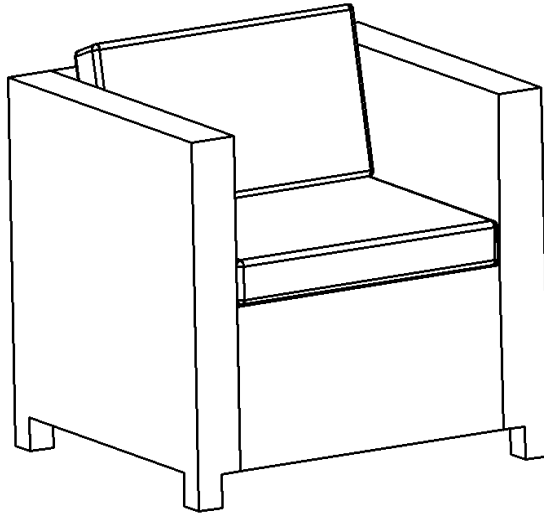



# Assembly Instructions

**Caution : You must read this before you proceed**



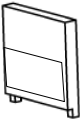

## Single Sofa

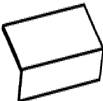
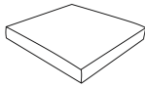
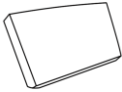

## Parts List

Label	Picture	Description	QTY
A		Sofa - Backrest	1
B		Right Armrest	1
C		Left Armrest	1
D		Sofa Seat	1
E		Seat Cushion	1
F		Back Cushion	1

# Hardware

Label	Picture	Description	QTY
①		Plastic Cap	13
②		Bolt M6*40mm	13
③		Washer	13
④		Spring Washer Ø16*2mm	13
⑤		Allen Key	1

## Assembly Preparation

Before Beginning Assembly:

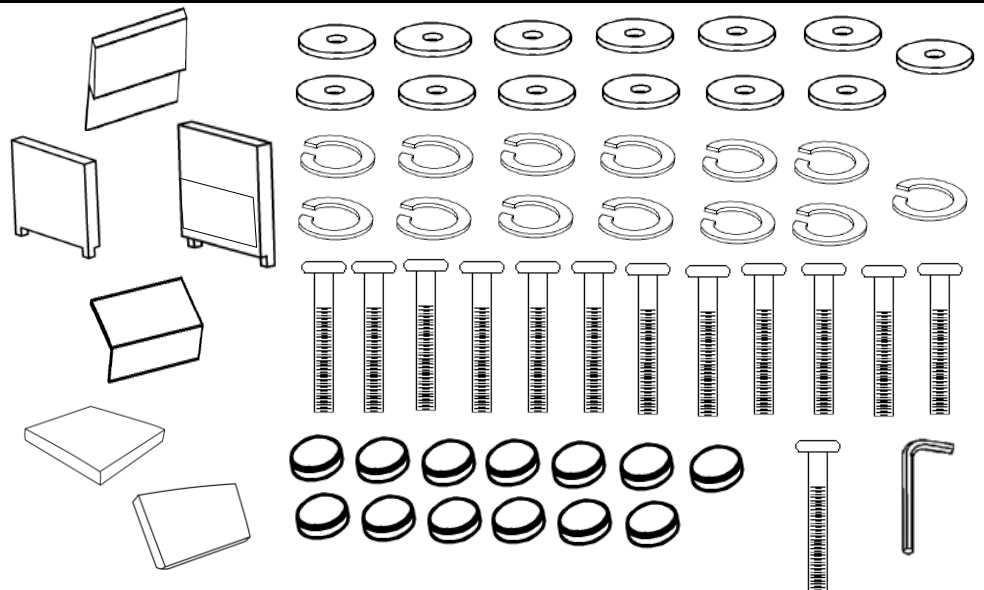

- Read instructions, cover to cover-



- Have 2 adults on hand for assembly-



- Do not assemble on flooring or carpet-



- Assemble on a clean non-marring surface (packing foam)-



- Save all packaging until finished-

# Assembly Steps

## Overview

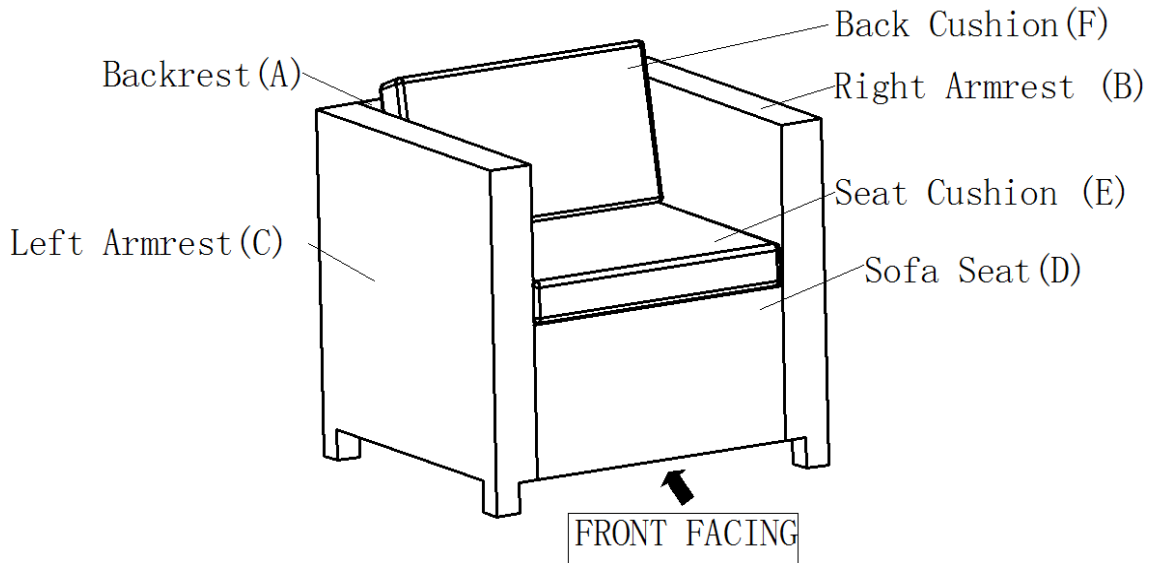

This Single Sofa has multiple parts and may require up to some 30 minutes to assemble. To give you an overview of the Single Sofa parts, the above picture is to help you put the various parts into perspective. Please read through the instructions herebelow to familiarise yourself with the parts and steps before assembly.

## Step 1

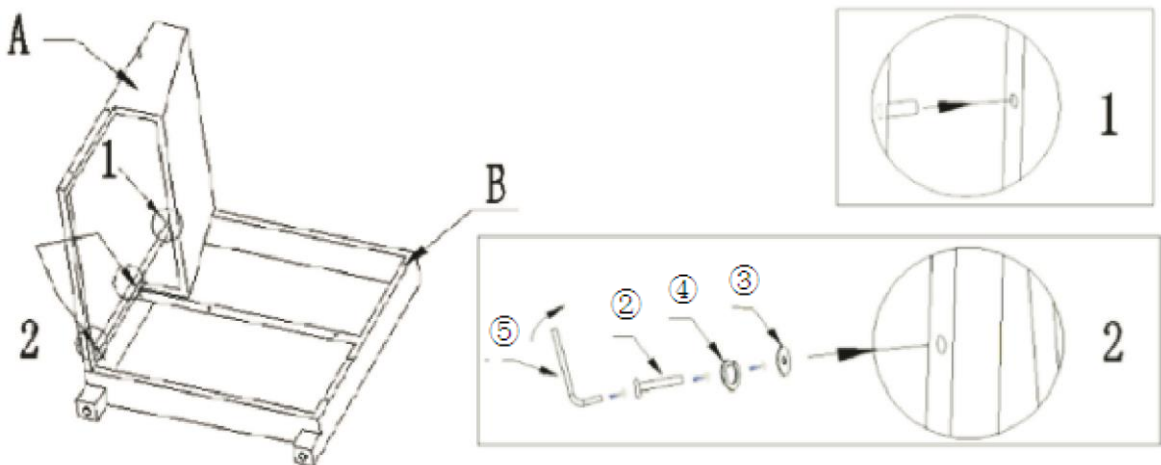

Open the carton and place all the parts onto a clean and soft surface.

Unpack all packages of hardware.

Place the Right Armrest (B) with its inside facing skywards.

Put the Backrest(A) against the Right Armrest(B), make the metal rod on the Backrest(A) insert into the MOUNTING POSITIONS of the Right Armrest(B) as picture 1 shows.

Then attach Backrest(A) and Right Armrest(B) together with hardware as picture 2 shows.

Use an Allen Key(⑤) to partially tighten these.

**Do not fully tighten the bolts.**

**It can happen that some of the PE wicker covers the bolt points, preventing easy assembly the PE wicker should not be cut but only moved away from the mounting positions.**

## Step 2

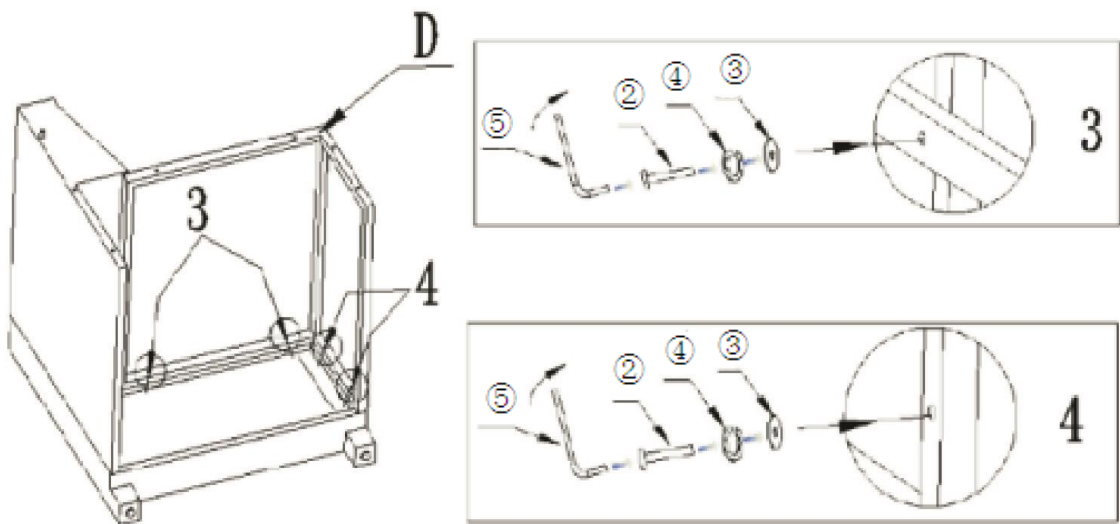

Place the Seat (D) between the Right Armrest(B) and Backrest(A).  
Attach the Seat(D) to the Right Armrest(B) with hardware as picture 3 and 4 shows.  
Use an Allen Key(5) to partially tighten these.  
**Do not fully tighten the bolts.**

## Step 3

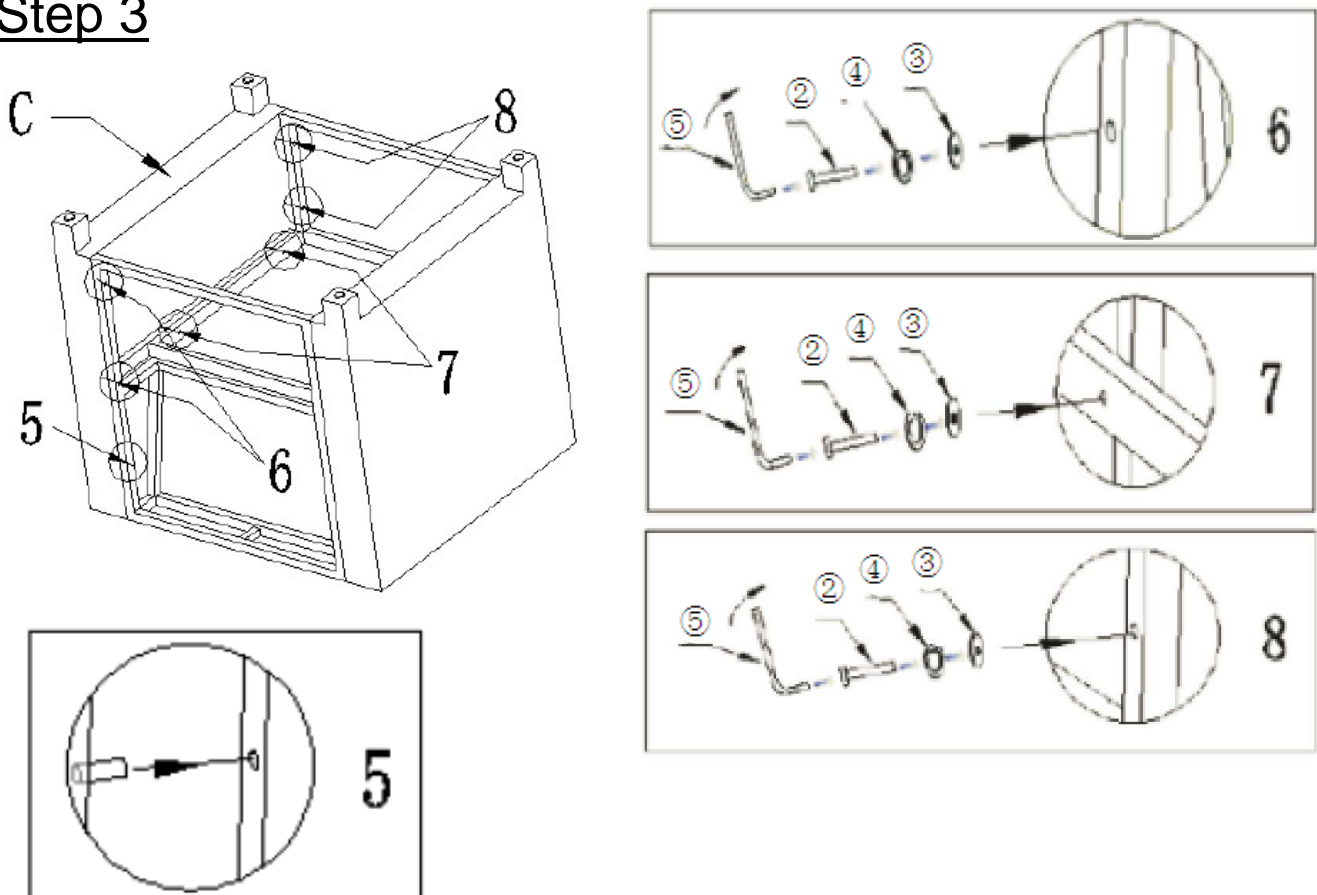

Place the Left Armrest (C ) against the Backrest(A) and Seat(D).  
Make the metal rod on the Backrest(A) insert into the MOUNTING POSITIONS of the Left Armrest(C ) as picture 5 shows.  
Attach the Left Armrest(C ) to Backrest(A) with hardware as picture 6 shows.  
Attach the Left Armrest(C ) to Seat(D) with hardware as picture 7 and 8 shows.  
Use an Allen Key(5) to partially tighten these.  
**Do not fully tighten the bolts.**

## Step 4

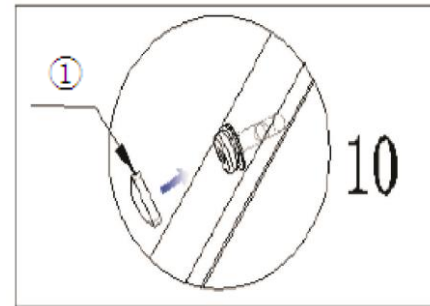
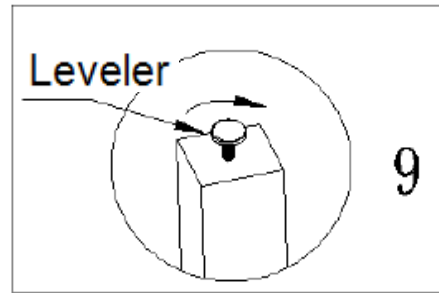
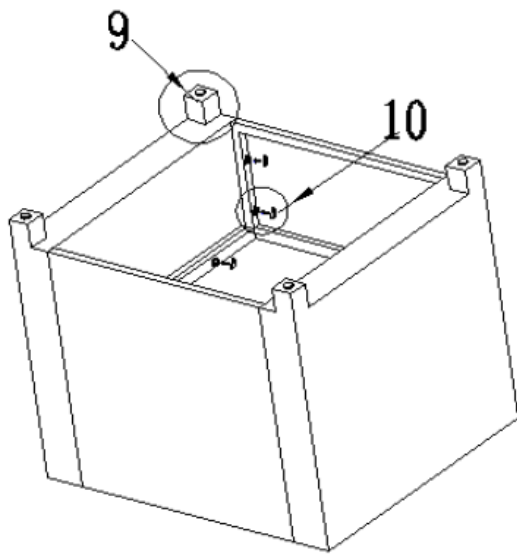

Tighten all bolts completely.

Put the Plastic Cap(①) to cover the bolt heads, adjust the Leveler to ensure good stability.

## Step 5

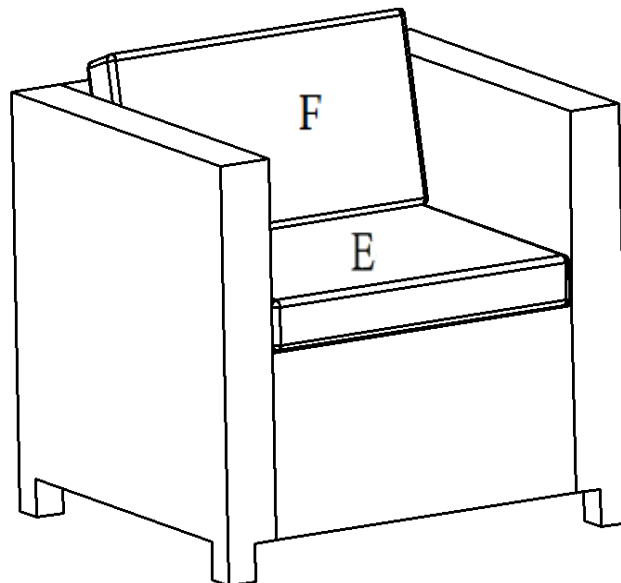





















Turn the Sofa right side up.

Place the Seat Cushion(E) and Back Cushion(F) onto the Sofa.

Your Sofa is ready for use.

Caution: This Chair can only be used on a flat, level surface.

## Care & Maintenance

-   Do not put hot items directly on furniture surface
  -   Do not clean furniture with harsh cleansers or polish.
  -   To obtain the longest lifespan of your outdoor products, minimizing exposure to direct sunlight is recommended.
  -   Children should not climb or jump on the furniture.
  -   Do not write on furniture without a padded barrier to protect the surface.
  -   To obtain the longest lifespan of your outdoor products, avoid extended and lengthy exposure to rain, snow, and direct sunshine. Whenever possible cover the product and /or place under patio or awnings.
  -   Not for commercial use. For residential use only .
  -   Stains may be removed with mild soap solution and damp cloth.
  -   Keep away from sources of ignition.
- 
-   Dust and pick-up spills using a clean, non-colored, lint-free cloth .

## Questions & Answers about Proposition 65

### • What is Proposition 65?

Proposition 65 requires businesses to provide warnings to Californians about significant exposures to chemicals that cause cancer, birth defects or other reproductive harm. These chemicals can be in the products that Californians purchase, in their homes or workplaces, or that are released into the environment. By requiring that this information be provided, Proposition 65 enables Californians to make informed decisions about their exposures to these chemicals.

Proposition 65 also prohibits California businesses from knowingly discharging significant amounts of listed chemicals into sources of drinking water.

Proposition 65 requires California to publish a list of chemicals known to cause cancer, birth defects or other reproductive harm. This list, which must be updated at least once a year, has grown to include approximately 900 chemicals since it was first published in 1987.

### • What types of chemicals are on the Proposition 65 list?

The list contains a wide range of naturally occurring and synthetic chemicals that include additives or ingredients in pesticides, common household products, food, drugs, dyes, or solvents. Listed chemicals may also be used in manufacturing and construction, or they may be byproducts of chemical processes, such as motor vehicle exhaust.

### • What does a warning mean?

If a warning is placed on a product label or posted or distributed at a workplace, a business, or in rental housing, the business issuing the warning is aware or believes that it is exposing individuals to one or more listed chemicals.

By law, a warning must be given for listed chemicals unless the exposure is low enough to pose no significant risk of cancer or is significantly below levels observed to cause birth defects or other reproductive harm.

### • Where can I get more information on Proposition 65?

If you have specific questions on the administration or implementation of Proposition 65, you can contact OEHHHA's Proposition 65 program at [P65.Questions@oehha.ca.gov](mailto:P65.Questions@oehha.ca.gov), or by phone at (916) 445-6900.