

ASSEMBLY INSTRUCTIONS

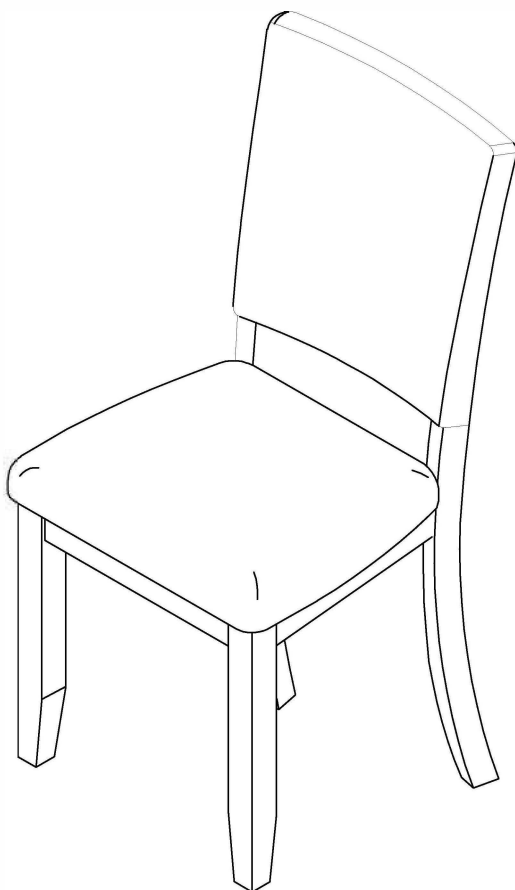

TOOLS REQUIRED



Screwdriver
(Not included)



(Included)
Allen Wrench

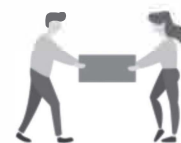

2 - People

ASSEMBLY RATING



EASY —————> DIFFICULT

The Assembly Rating is a 5-point system showing the level of effort needed to assemble a specific product.

SIDE CHAIR



- Please keep instructions for future reference.
- Check the quantity and irregularity of parts and hardware before you start.

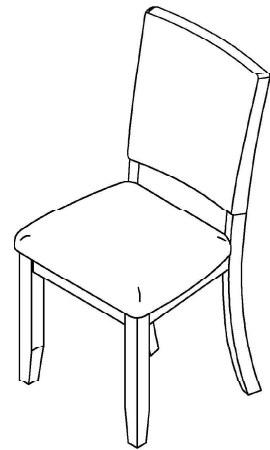

PARTS

1

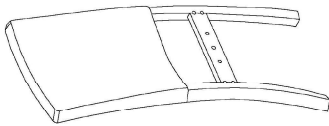

**BACK FRAME
WITH CUSHION**

1 x 4 pcs.

2

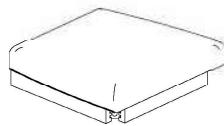

**SEAT FRAME
WITH CUSHION**

1 x 4 pcs.

3

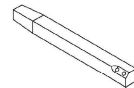

FRONT LEGS

2 x 4 pcs.

HARDWARE

A



BOLT
Ø1/4" x 3"
4 x 4 pcs.

B

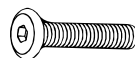

BOLT
Ø1/4" x 2-1/4"
4 x 4 pcs.

C



BOLT
Ø1/4" x 1-3/8"
2 x 4 pcs.

D



SPRING WASHER
Ø1/4"
10 x 4 pcs.

E



FLAT WASHER
Ø1/4"
10 x 4 pcs.

F



ALLEN WRENCH
M4
1 x 4 pcs.

ASSEMBLY INSTRUCTIONS

1

DO NOT FULLY TIGHTEN ALL BOLTS UNTIL ASSEMBLY IS COMPLETED.

- Part 3 x2pcs
- Hardware B x4pcs
- Hardware D x4pcs
- Hardware E x4pcs

x4

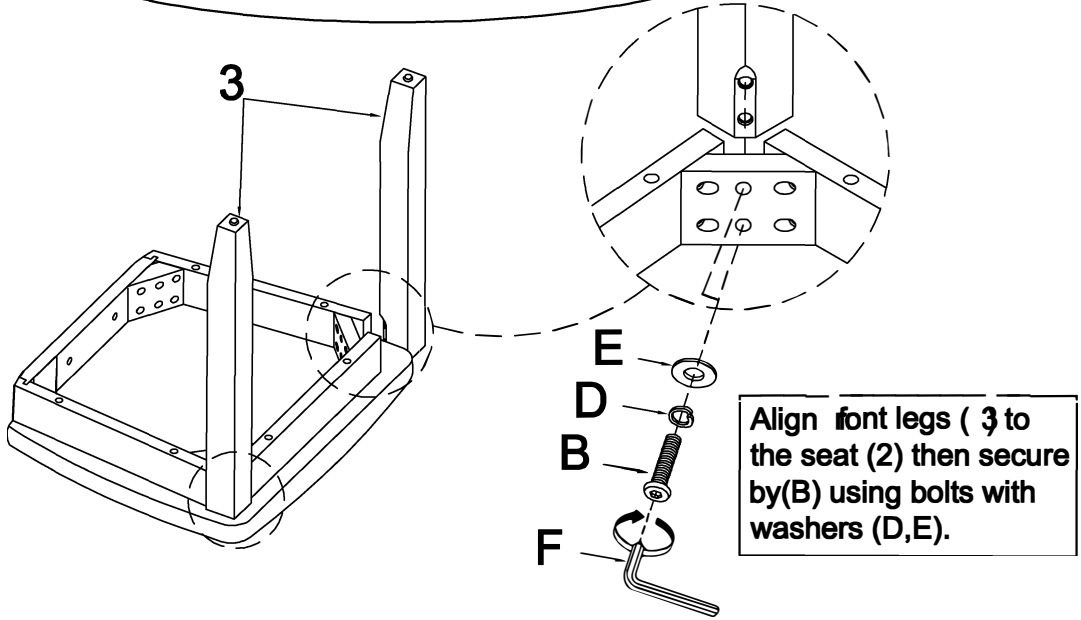

2

DO NOT FULLY TIGHTEN ALL BOLTS UNTIL ASSEMBLY IS COMPLETED.

- Part 1 x1pc
- Part 2 x1pc
- Hardware A x4pcs
- Hardware C x2pcs
- Hardware D x6pcs
- Hardware E x6pcs

x4

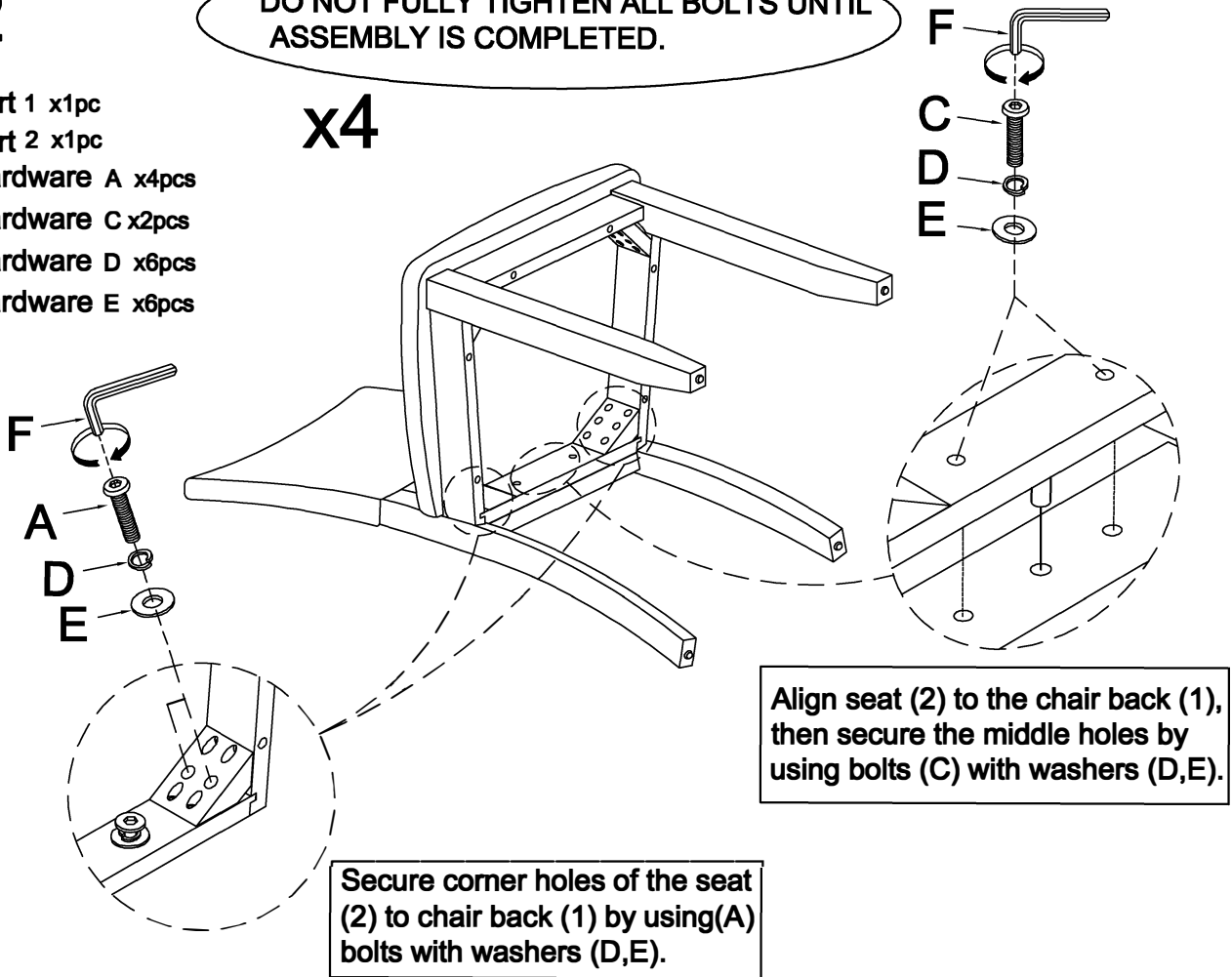

ASSEMBLY INSTRUCTIONS

3

x4

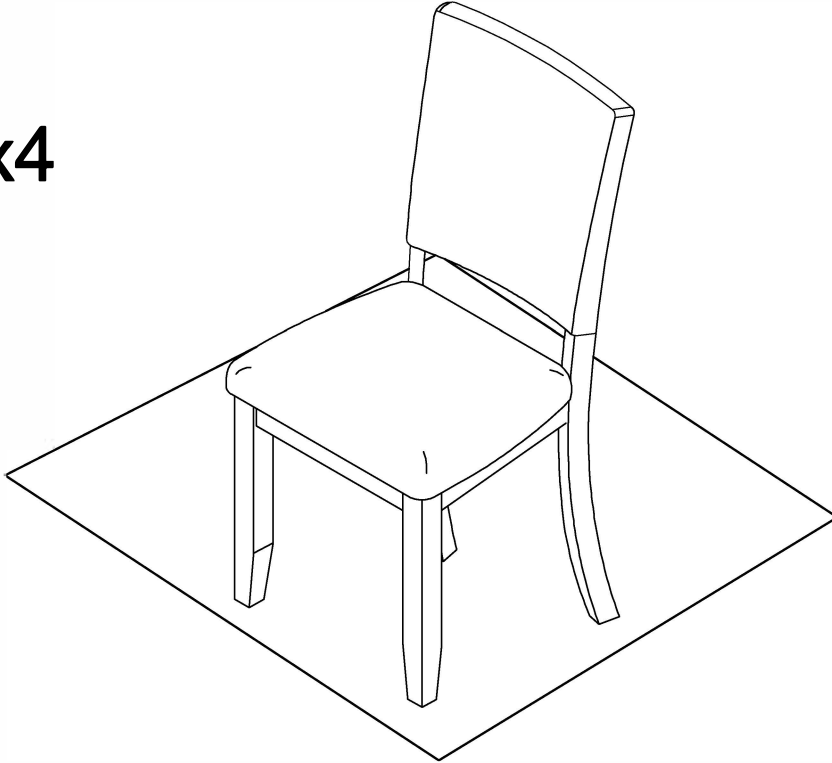

Place the chair on a flat surface, ensure it is stable and not wobbling, and then tighten all screws

4

x4

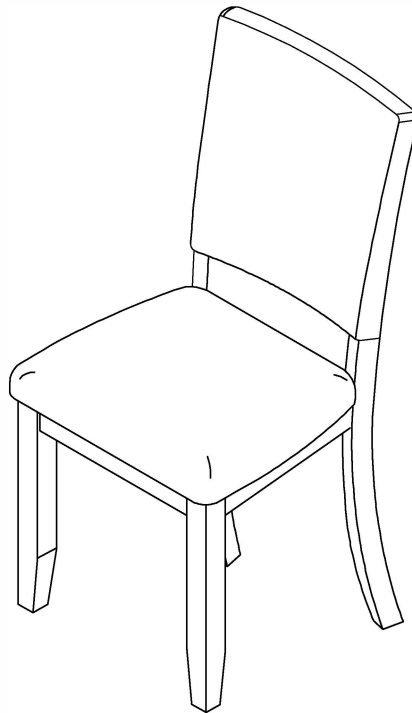

ASSEMBLY COMPLETED

Please ensure the furniture rests on an even and flat surface. If the product wobbles or feels loose, double-check all bolts and/or screws are properly tightened and secured.

- ✓ **Keep this handy!**
Please retain this instruction manual and any order-related information for future reference.
- **Lift, don't drag!**
To avoid damage to product please always LIFT the product when transporting or adjusting the placement.

This product is intended for RESIDENTIAL USE ONLY and not for commercial use.