

# Installation & Assembly

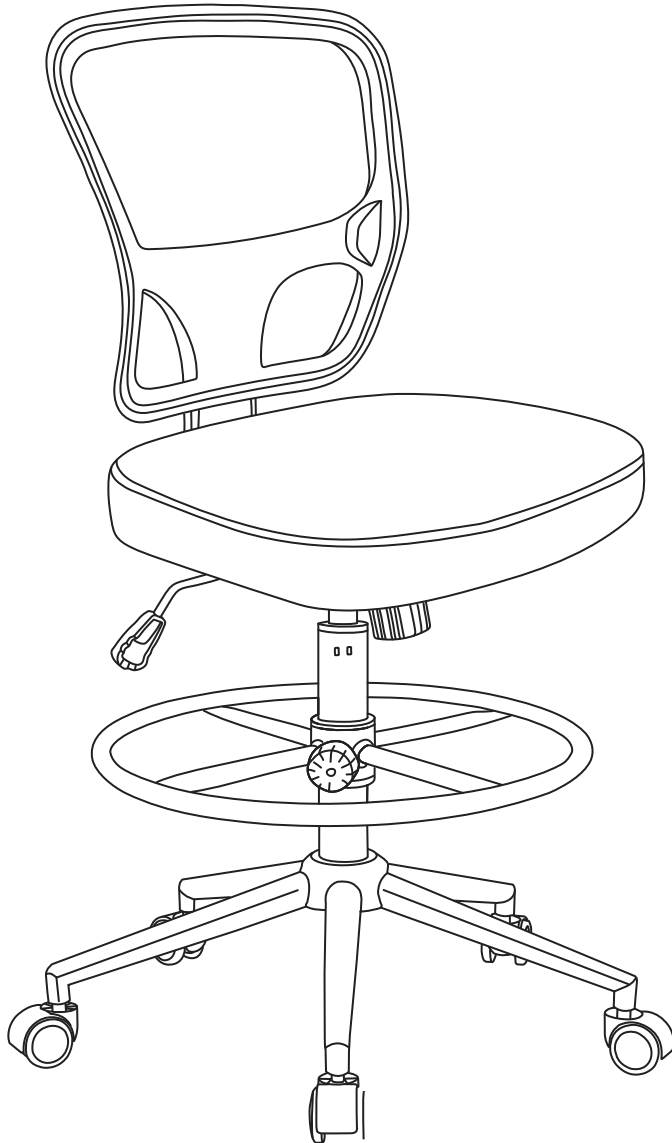

# Instruction Manual

## Contents

Make sure that the package contains the following parts:

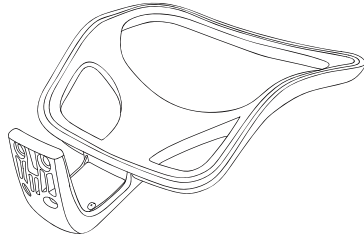

① Back Cushion(1)

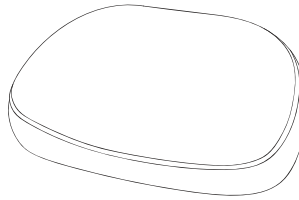

② Seat Cushion(1)

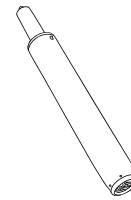

③ Gas Lift(1)

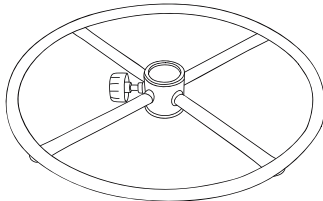

④ Foot Ring(1)

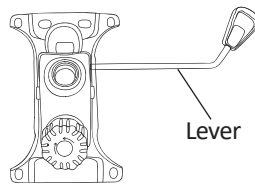

⑤ Seat Plate(1)

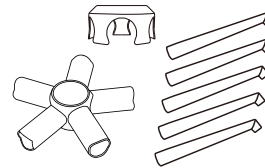

⑥ Star Base(1)

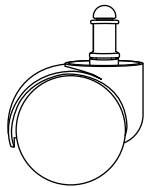

⑦ Casters(5)



Ⓐ Bolts M6\*20mm(2)

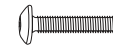

Ⓑ Bolts M6\*30mm(2)



Ⓒ Bolts M6\*35mm(2)



Ⓓ Bolts M6\*40mm(2)



Ⓔ Bolts M6\*14mm(5)



Ⓕ Washers M6\*18mm(8)

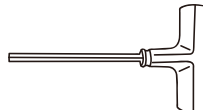

Ⓖ T Handle Wrench(1)

# Assembly Instructions

**Step 1:** Attach the seat plate to the seat cushion using B bolts (2 Pcs) at Front, A bolts (2 Pcs) at Back and F (4 Pcs) Washers. Tighten all the bolts with the wrench (G), being careful not to miss-thread the bolts or damage the seat.

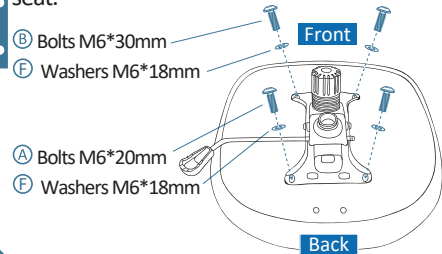

**Step 2:** Attach the back cushion to the seat cushion using C bolts (2 Pcs), D bolts (2 Pcs) and F washers (4 Pcs). Align all the holes, put all the bolts into the holes, then tighten them with the wrench (G) in turn. Note: Using D bolts at back side of the seat cushion.

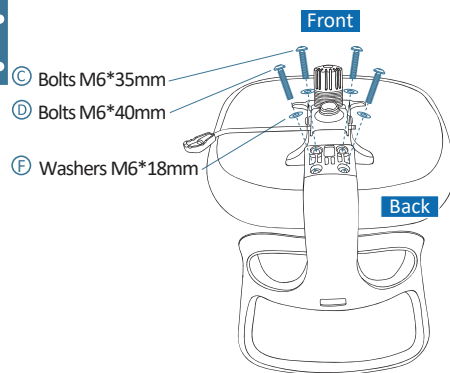

**Step 3:** Turn the Star Base upside down, insert 5 detachable feet in turn to the Star Base, align all the holes and fix the feet with E Bolts (5 Pcs).

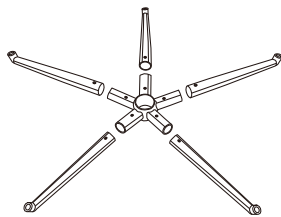

**Step 4:** Press Rolling Casters (5 Pcs) into the hole at the end of each base leg. Then turn over the Star Base and insert the Base Cover. Lastly, insert the Gas Lift into the Central hole as shown. Slide the foot ring around the gas lift and tighten into place by turning the tension knob to the right.

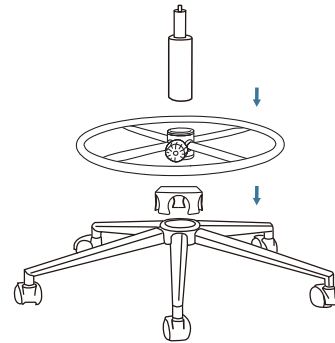
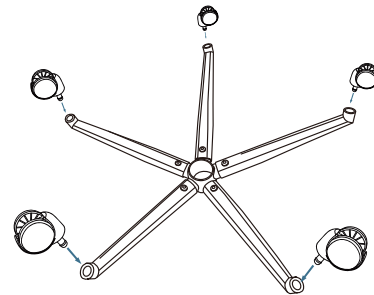

**Step 5:** Attach the seat cushion down onto the gas lift firmly until the connection is secure

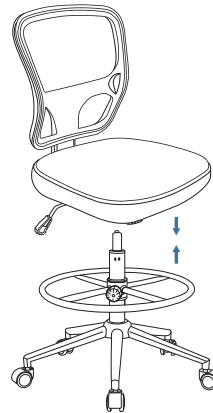

# Adjustment

## Adjusting the seat height

To raise your seat, lean forward to lift your body weight from the seat, then pull up the lever. To lower the seat, pull up the lever while you're seated

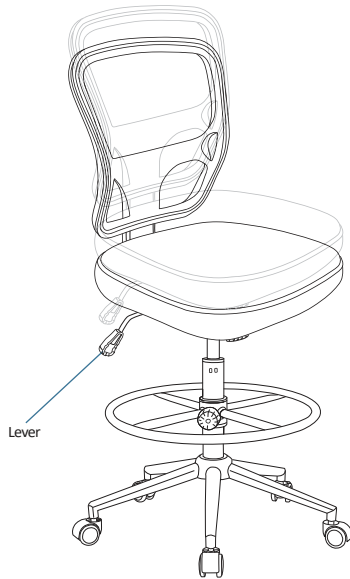

## To operate the rocking function

To let your chair rocking, pull the lever out. To stop your chair from rocking, push the lever in

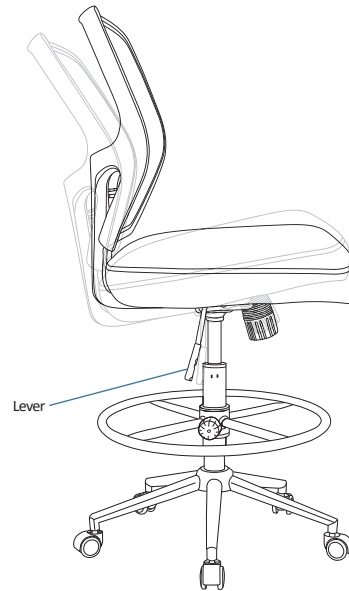

## Adjusting the seat tension

Turn the tilt knob clock wise to make it easier to rock your chair backwards  
Turn the tilt knob counter-clockwise to make it harder to rock your chair backwards

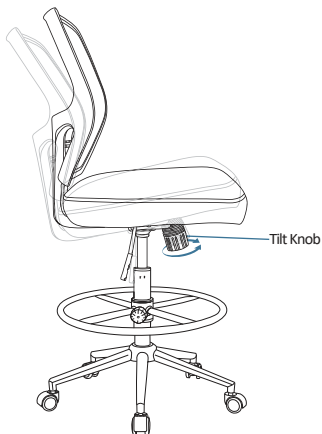

## Adjusting the foot ring

Turn the tilt knob on the foot ring counter-clockwise, then the foot ring can be raised up or down to your desired height

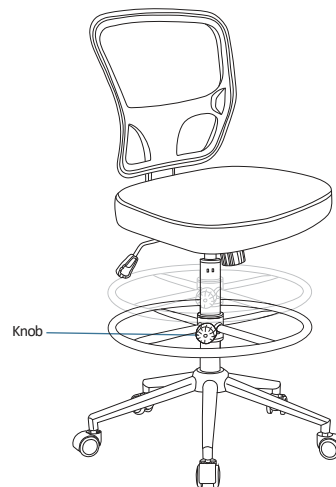

## Safety and Compliance

- Use care when handling
- Please read the instructions completely before assembly
- Remove all parts from the carton and ensure all parts are included prior to assembly
- Assemble the chair on the carton or carpet to prevent scratching the chair
- Be careful not to cross-thread screws
- Do not use power tools

## Specifications

Seat Height:	22-29.9 INCH
Overall Height:	38.6-46.5 INCH

**ATTENTION: ALL REPAIR WORK OR EXCHANGE FOR THE HEIGHT ADJUSTABLE GAS LIFT MUST BE DONE BY SPECIALISTS**