

Assembling Instruction

PRODUCT DIMENSIONS: 1000\*500(995)\*435(565)

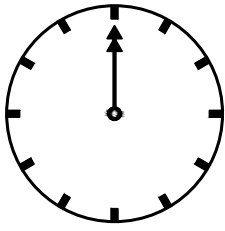

30 MIN  
APPROXIMATE ASSEMBLY TIME

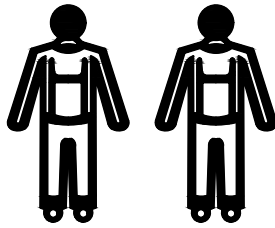

Single-Person Assembly

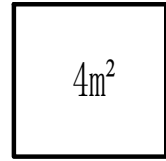

FLOOR AREA 2M\*2M  

---

REQUIRED ASSEMBLY SPACE

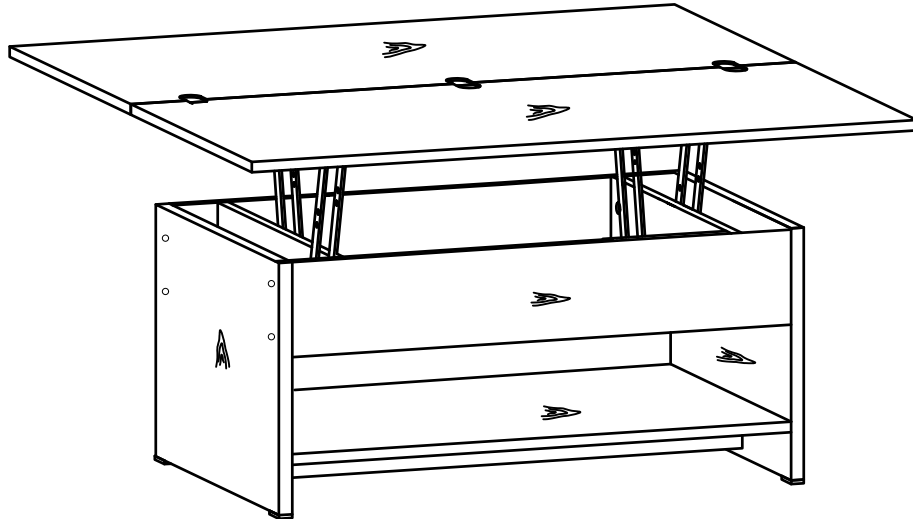

## General Guidelines - Important Notice

### ● General Guidelines - Important Notice

Before starting assembly, be sure to read these instructions in full.

Please keep this manual and hand it over when transferring the product. This summary may not cover all variants or every detail of the steps to be considered. If you have any questions during installation, please contact us and we will provide assistance within 24 hours.

### ● Precautions

This product is for indoor use only. Assembly and use must be carried out in accordance with the instructions.

To avoid damaging your product, ensure that your electric drill is set to a low-torque mode. Do not expose the product to humid environments for extended periods to prevent mold growth. During assembly, first align all screws with their corresponding pre-drilled holes, then tighten them one by one.

Check the screws regularly; they may loosen after long-term use. Retighten them if necessary to ensure stability and safety.

The seller shall not be liable for any damage or injury caused by improper assembly or use.

### ● Warnings

Children must not assemble this product. During assembly, keep children and pets away from the work area. Keep all small parts out of children's reach to prevent fatal risks from swallowing or inhalation. Children must not stand on, climb on, or play on the product to avoid serious bodily injury from product tipping. Keep plastic packaging bags out of children's reach to prevent potential suffocation hazards. Avoid contact between sharp objects, corrosive chemicals and the product to prevent product damage or bodily injury.

### ● Tip-over Warning!

Tipping furniture can cause serious or fatal crushing injuries. To prevent tipping, be sure to use the included wall anchoring device (if the product is not equipped with one). Purchase a wall anchoring device that matches your wall size. If in doubt, seek professional advice. Read and follow each step in the instructions carefully.

Do not allow children to climb on the furniture or hang items on it

Do not open multiple drawers at once

Do not place heavy objects in the top drawer

Do not place heavy objects on top of the furniture

Note that only the anti-tip nails are provided.

You will also need to prepare wall plugs and screws suitable for your wall type.

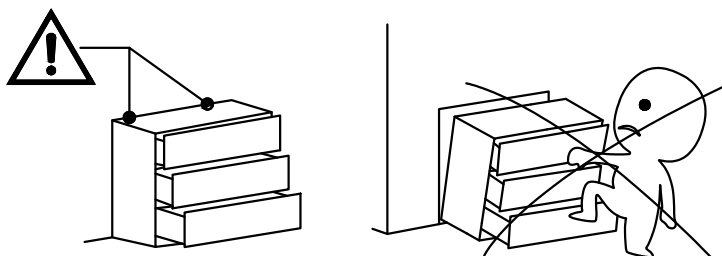

### ● Maintenance and Care

Clean the device only with a damp cloth. Inspect it regularly and use mild detergent; do not use bleach or abrasive cleaners to avoid damaging the device.

This device should not be disposed of with household waste and must be taken to a local government waste disposal center.

Tools required



Phillips screwdriver

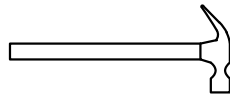

Hammer

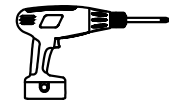

Electric drill

Ruler - Use this ruler to help correctly identify the screws

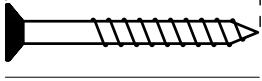
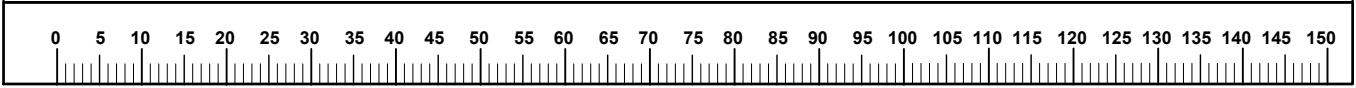

The screws length is measured from the head to the point (30mm screw shown).  
Note: be sure to use the proper screws to avoid damaging the parts.

Using Camlocks

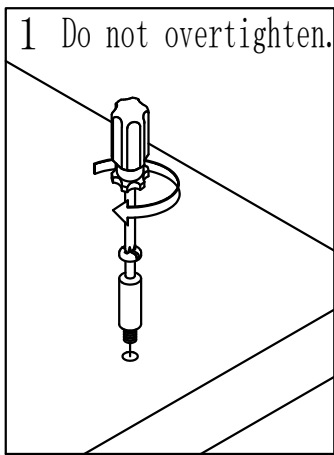

Step 1: Following the assembly instructions, use a screwdriver to connect the cam dowel.

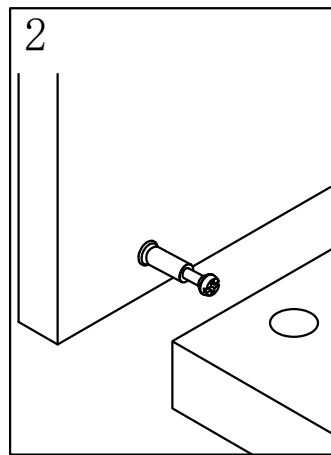

Step 2: Insert the cam dowel into the entry hole.

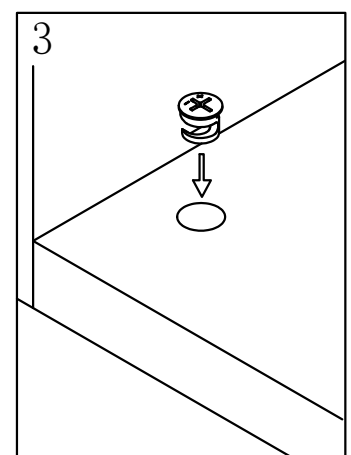

Step 3: Insert the cam lock as shown. Make sure the arrow on top of the cam lock points toward the opening where the dowel enters.

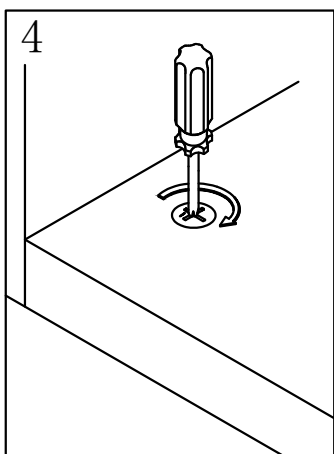

Step 4: Turn the cam lock clockwise with a screwdriver. You will hear a click when it is fully locked. The joint is now secured.

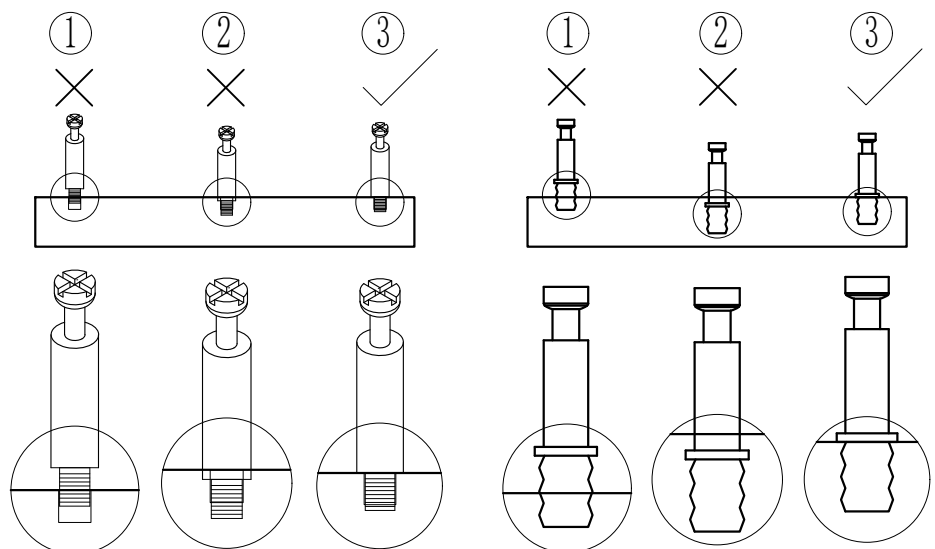

Please place the three-in-one and two-in-one components in the correct depth positions as shown in the diagram. Otherwise, the product components will not be able to connect properly.

# Accessories List

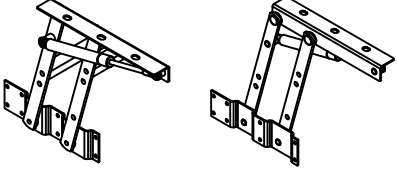
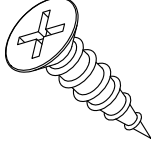
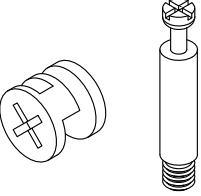
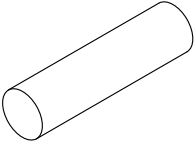
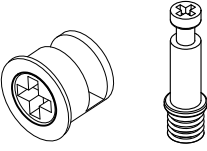
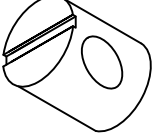
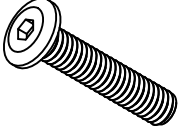
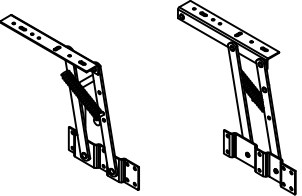
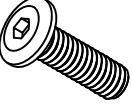
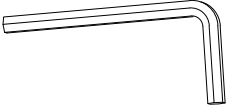
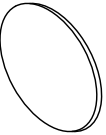
<p>(A) X1sets(left&amp;right)</p>  <p>B04H-2 (10KG)</p>	<p>(B) X32+4</p>  <p>ST4*16</p>	<p>(C) X12+1</p>  <p>28MM</p>
<p>(D) X24</p>  <p>φ 8*30</p>	<p>(E) X18+2</p>  <p>20MM</p>	<p>(F) X8</p>  <p>φ10*12</p>
<p>(G) X8</p>  <p>M6*40</p>	<p>(H) X1set(left&amp;right)</p>  <p>B04Q (1KG)</p>	<p>(I) X8</p>  <p>M6*12</p>
<p>(J) X1</p>  <p>S=4</p>	<p>(K) X12</p>  <p>φ22*1</p>	

# Assembling Instruction

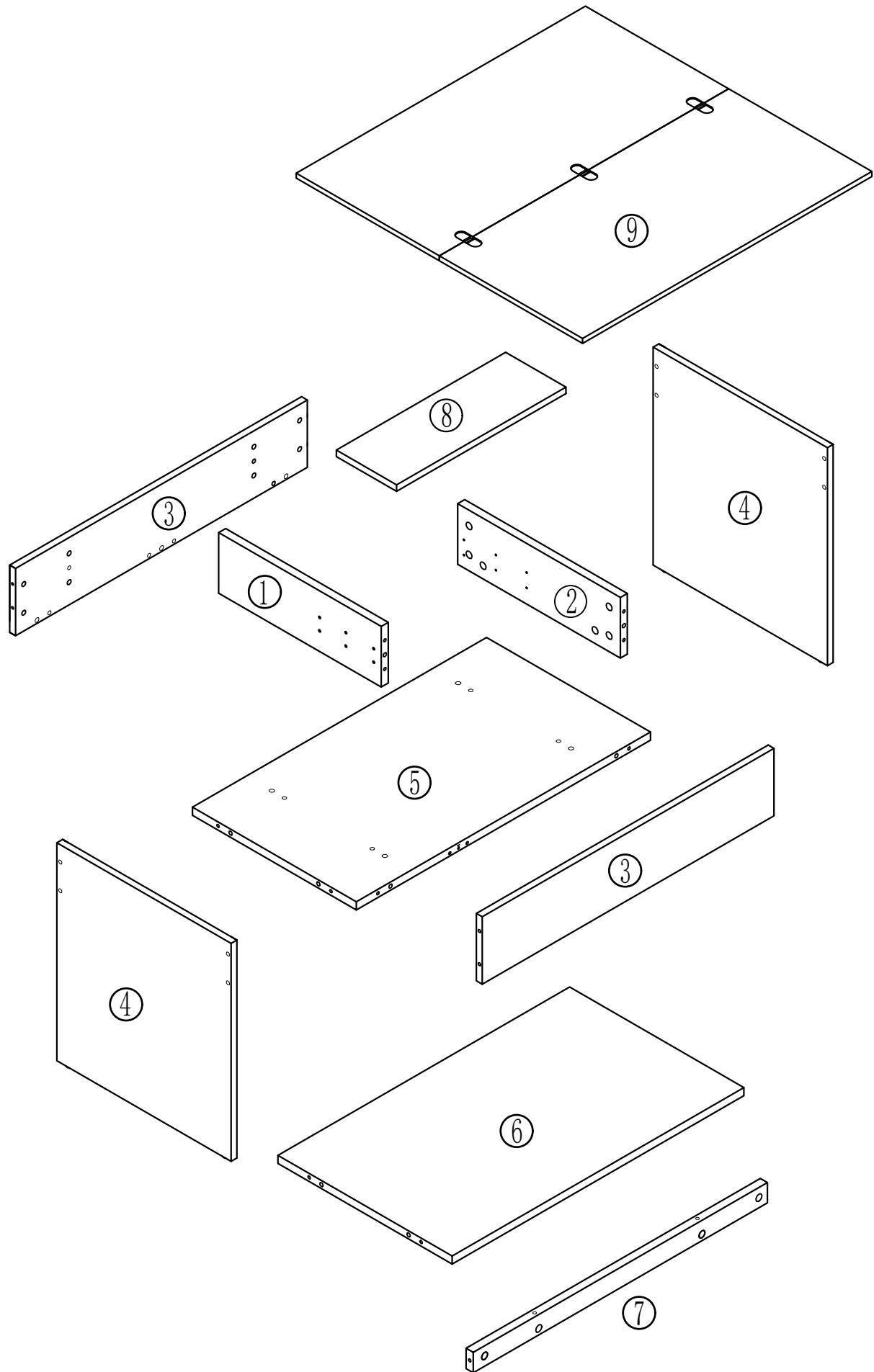

# Assembling Instruction

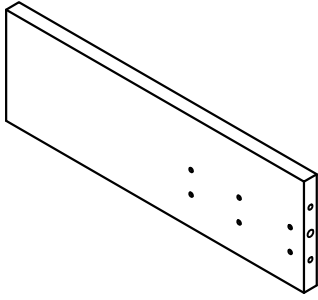

① X1 left

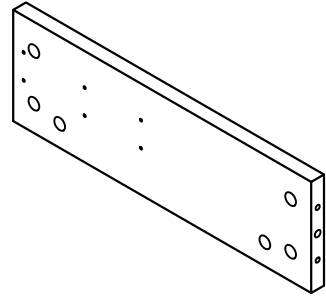

② X1 right

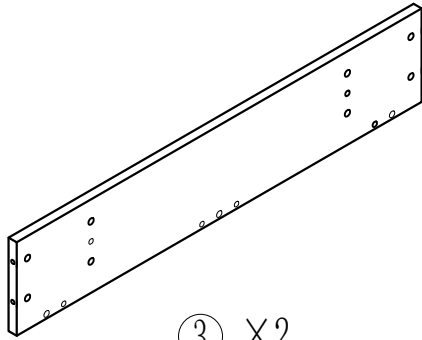

③ X2

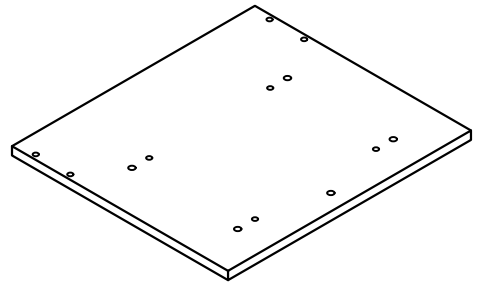

④ X2

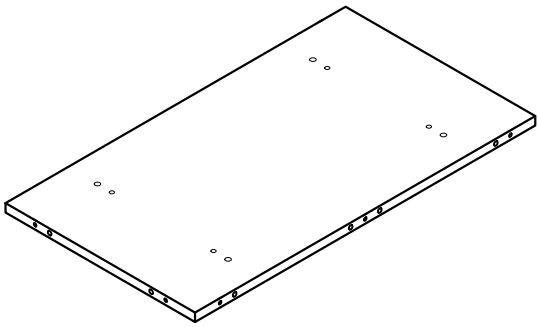

⑤ X1

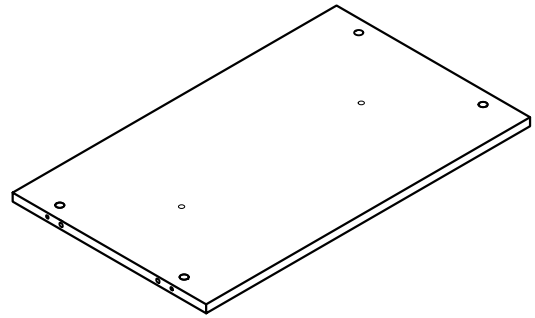

⑥ X1

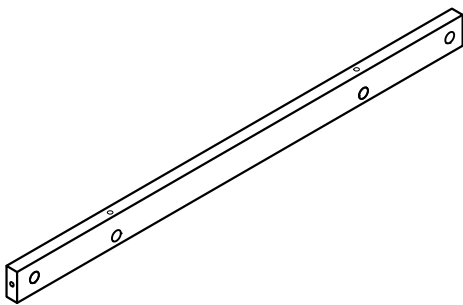

⑦ X1

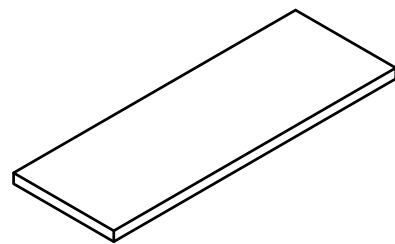

⑧ X1

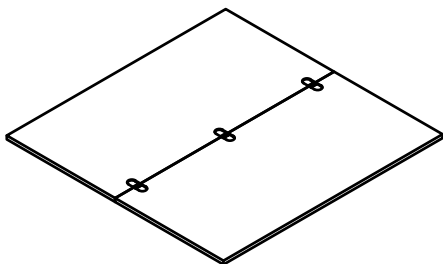

⑨ X1

# Assembling Instruction

## Step 1

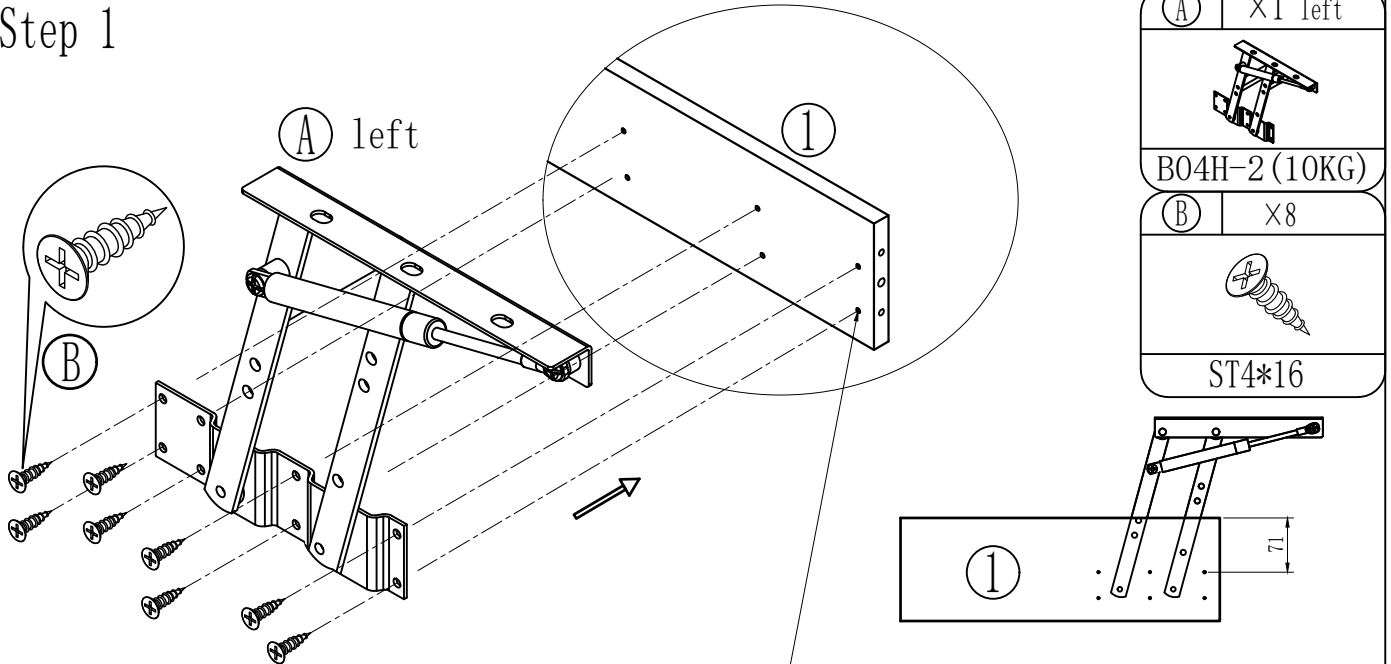

Note: The lifting parts are divided into two pieces (one for each side). To install this lifting part, 8 screw holes need to be drilled. However, on our board pieces, only 6 holes are drilled for each side. First, use four wooden screws to align and fix the lifting part according to the arrow indication positions on the side plate. For the other holes, simply drive in the wooden screws without the need for holes. The installation methods for the left and right lifting parts are the same.

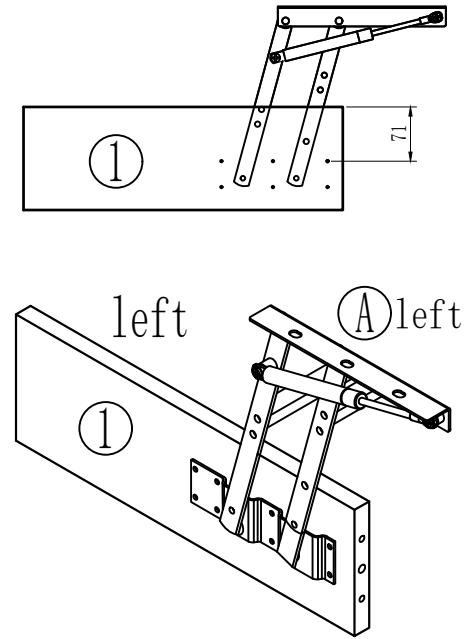

## Step 2

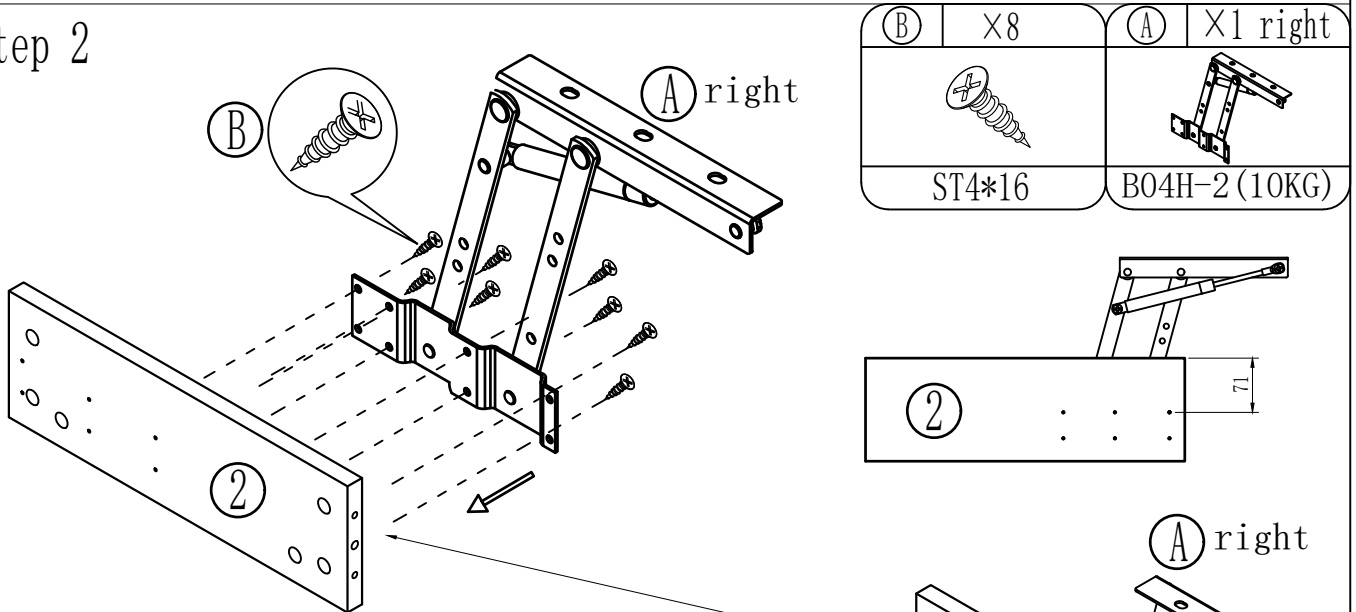

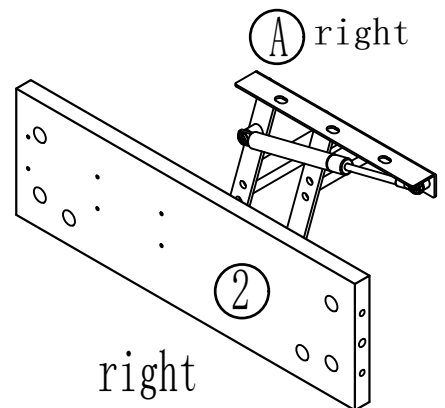

Note: The lifting parts are divided into two pieces (one for each side). To install this lifting part, 8 screw holes need to be drilled. However, on our board pieces, only 6 holes are drilled for each side. First, use four wooden screws to align and fix the lifting part according to the arrow indication positions on the side plate. For the other holes, simply drive in the wooden screws without the need for holes. The installation methods for the left and right lifting parts are the same.

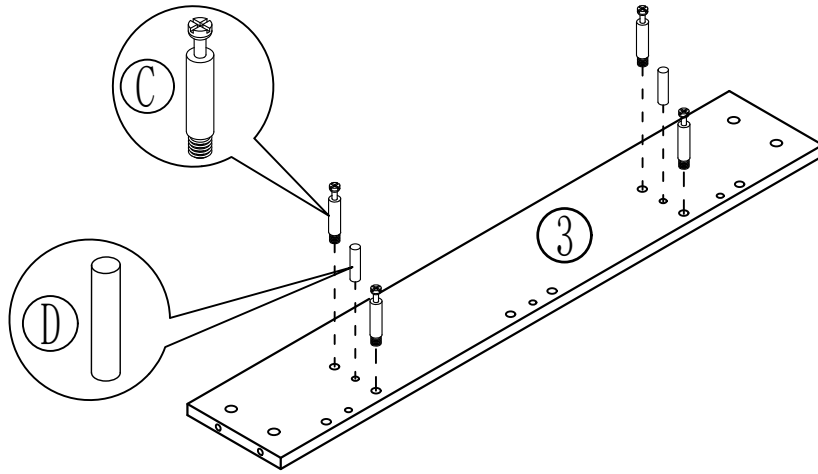

# Assembling Instruction

Step 3

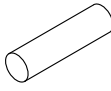

ⓓ	×2	ⓐ	×4
			
φ 8*30		28MM	

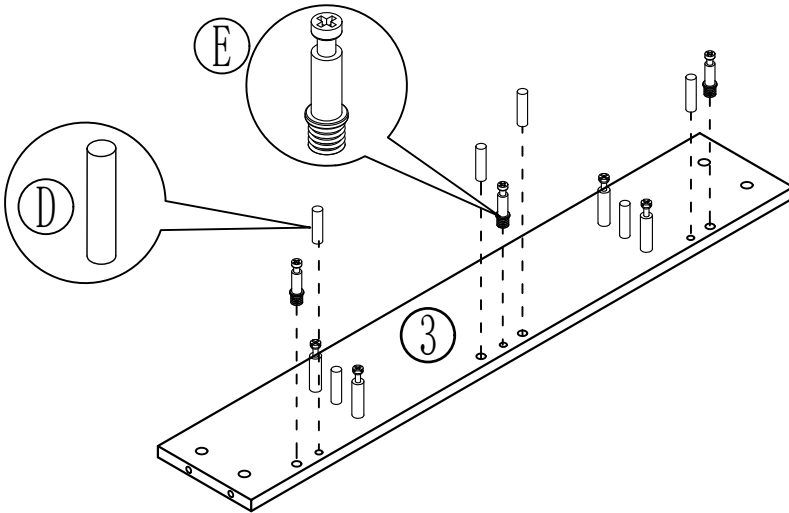

Step 4

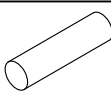
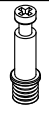

ⓓ	×4	ⓔ	×3
			
φ 8*30		20MM	

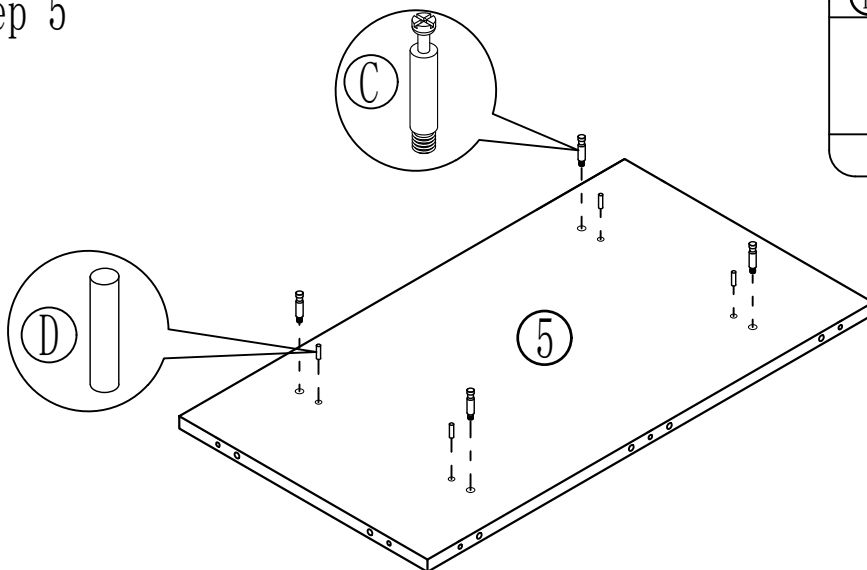
Step 5

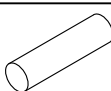

ⓓ	×4	ⓐ	×4
			
φ 8*30		28MM	

# Assembling Instruction

Step 6

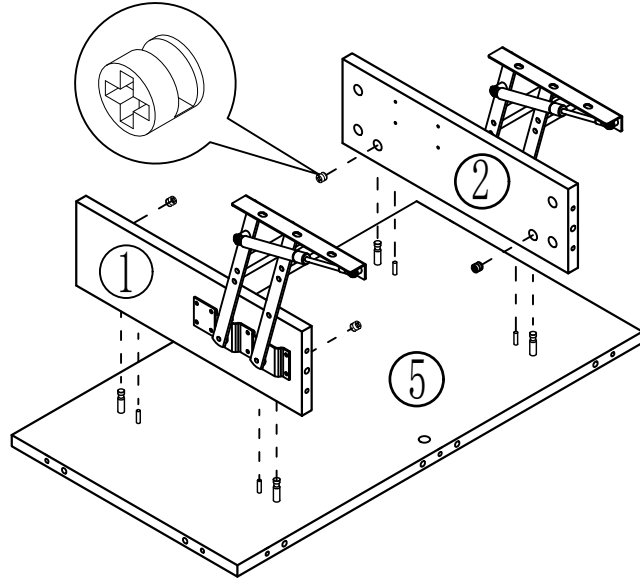

(C)	X4
φ15*13	

Step 7

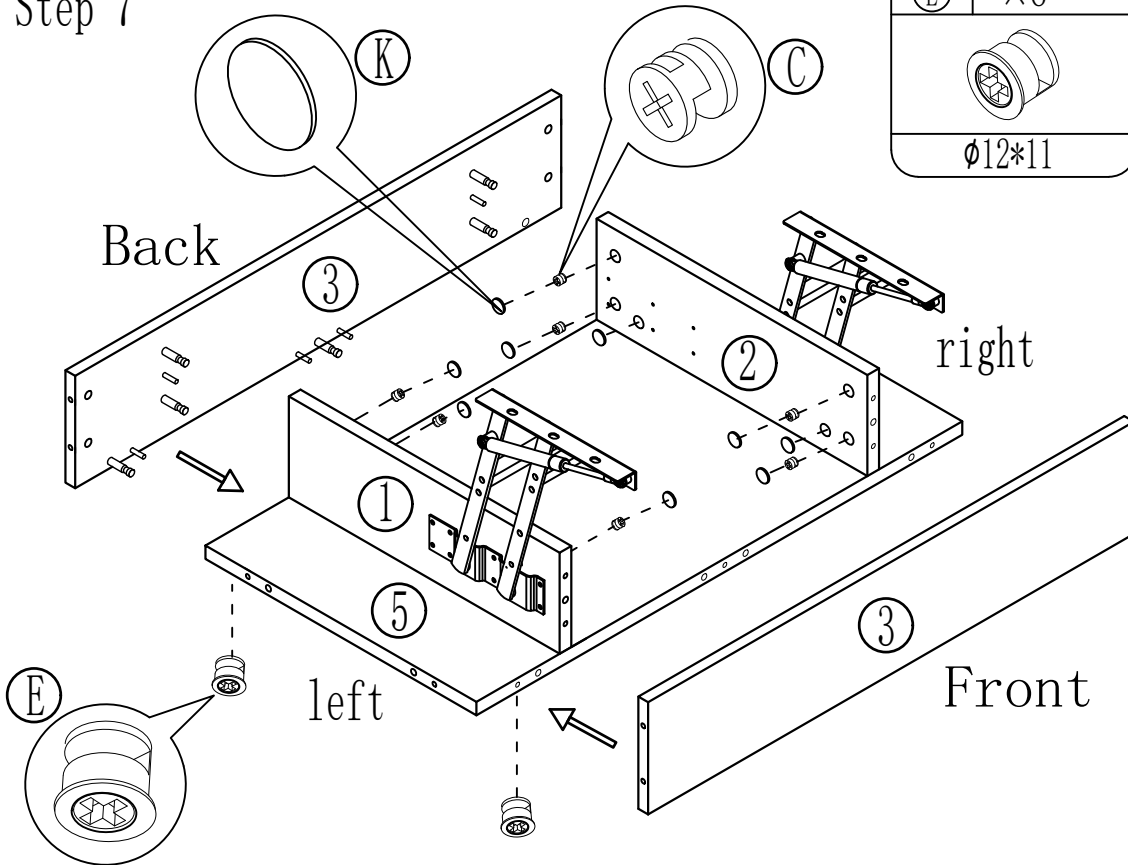

(E)	X6
φ12*11	

(C)	X8
φ15*13	

(K)	X12
φ22*1	

Step 8

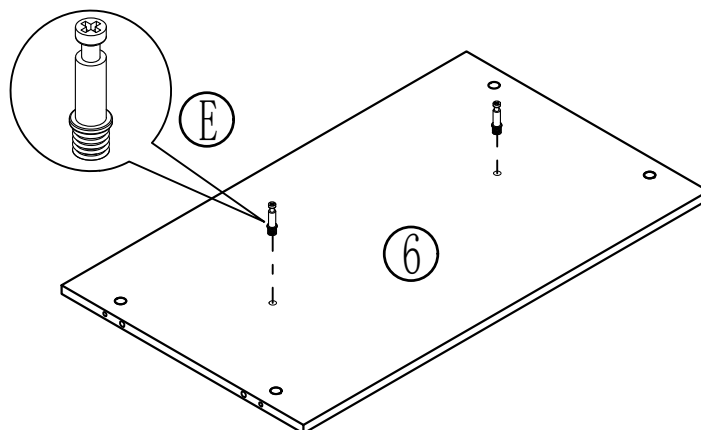

(E)	X4
φ12*11	

# Assembling Instruction

Step 9

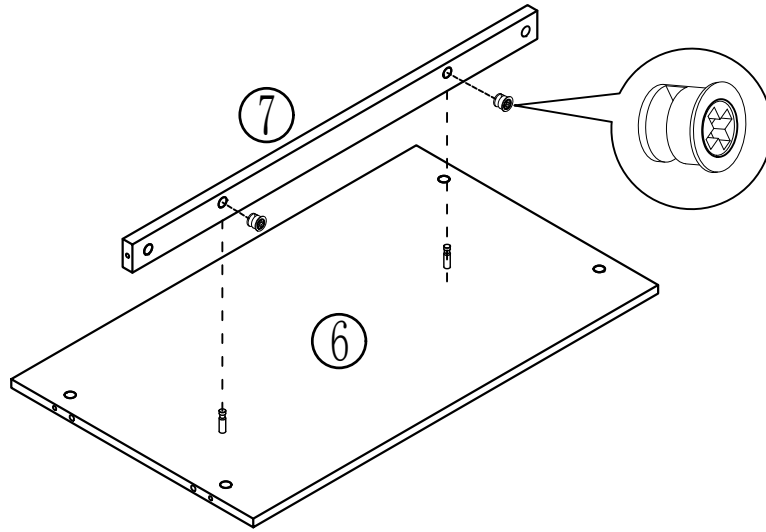

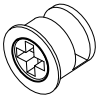
E	X2
	
φ12*11	

Step 10

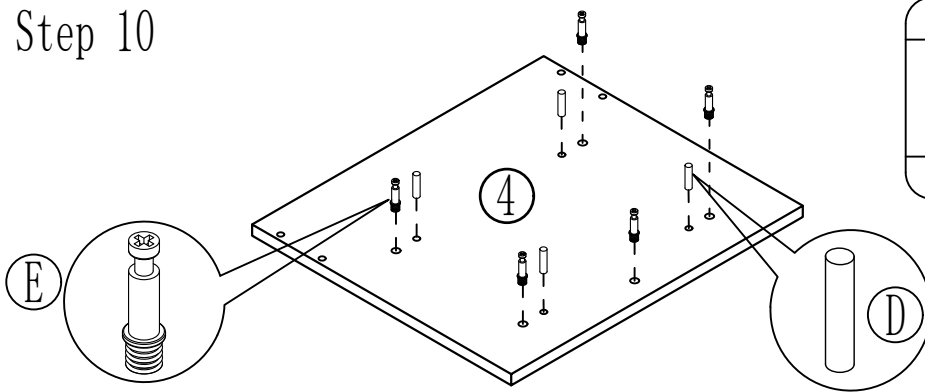

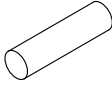

D	X4
	
φ 8*30	

E	X5
	
20MM	

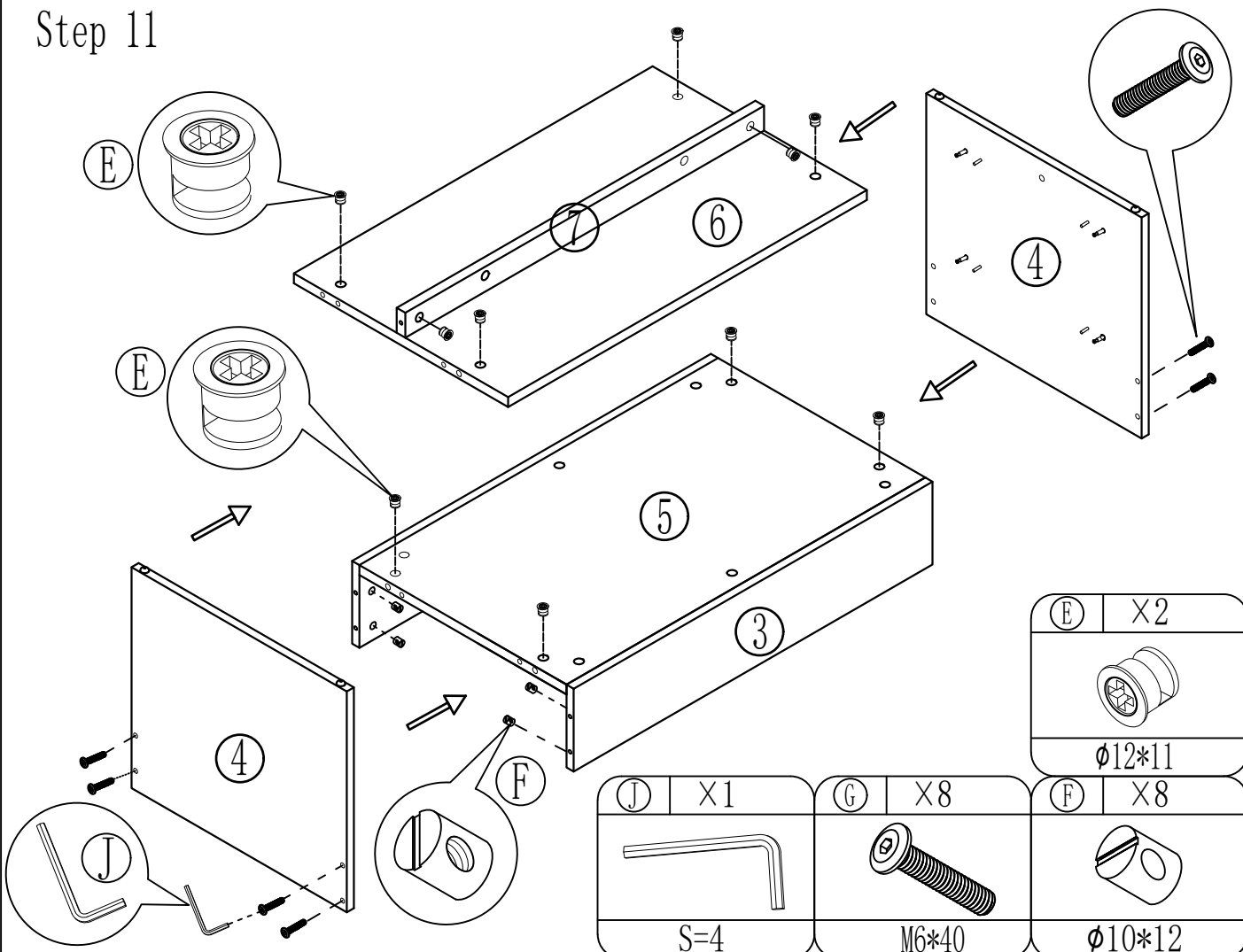
Step 11

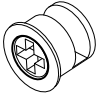

E	X2
	
φ12*11	

J	X1
	
S=4	

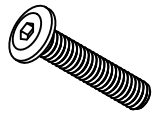
G	X8
	
M6*40	

F	X8
	
φ10*12	

# Assembling Instruction

## Step 12

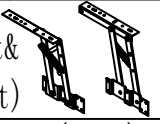
(B)	×16	(H)	×1 left
		(left & right) 	
ST4*16		B04Q (1KG)	

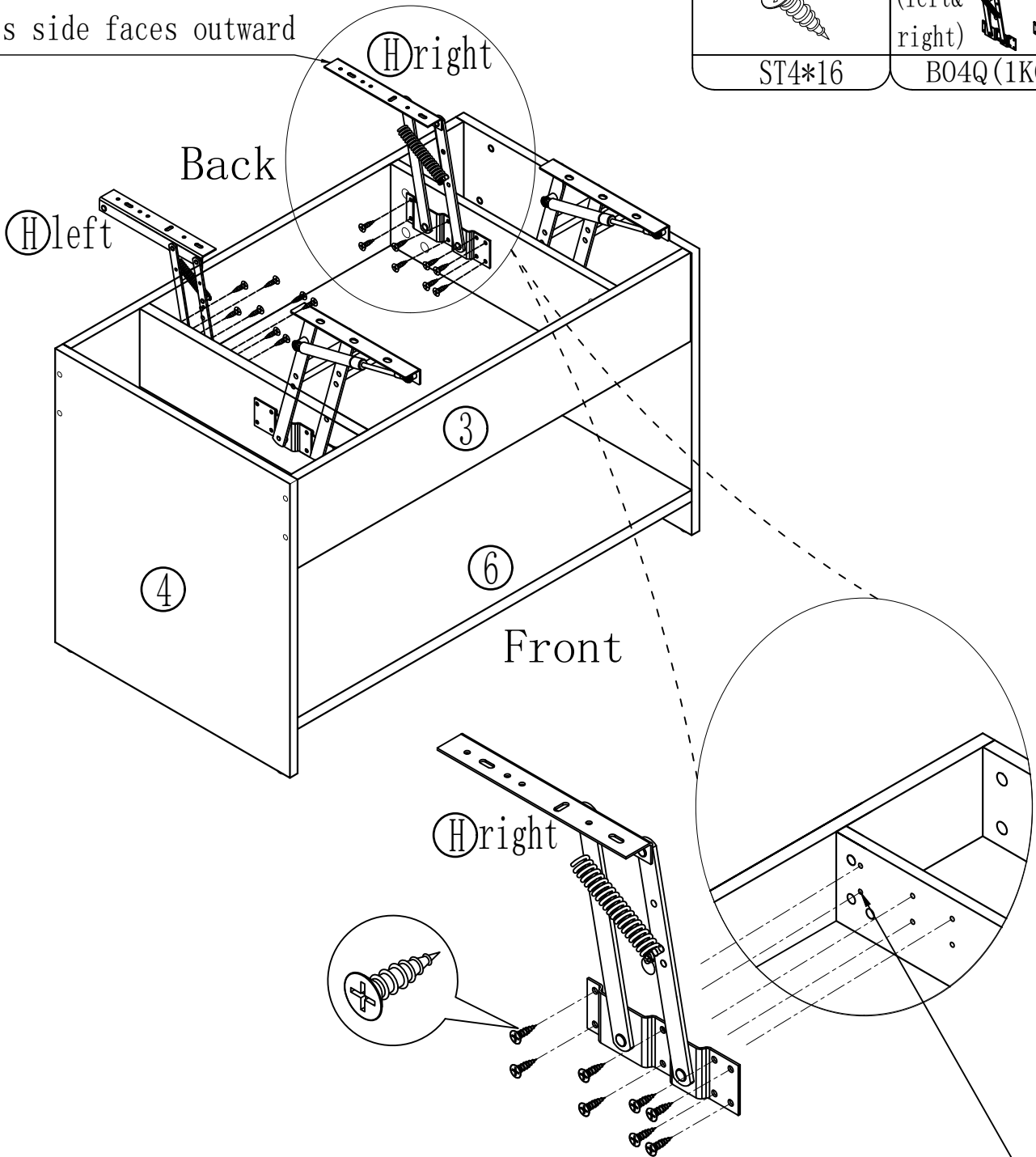

This side faces outward



Note: The lifting parts are divided into two pieces (one for each side). To install this lifting part, 8 screw holes need to be drilled. However, on our board pieces, only 6 holes are drilled for each side. First, use four wooden screws to align and fix the lifting part according to the arrow indication positions on the side plate. For the other holes, simply drive in the wooden screws without the need for holes. The installation methods for the left and right lifting parts are the same.

# Assembling Instruction

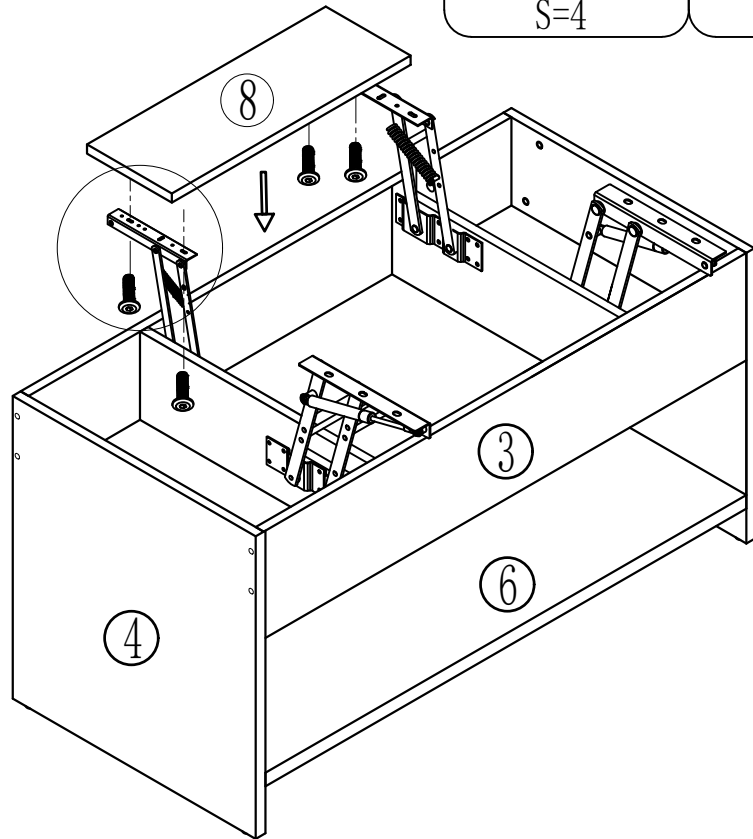
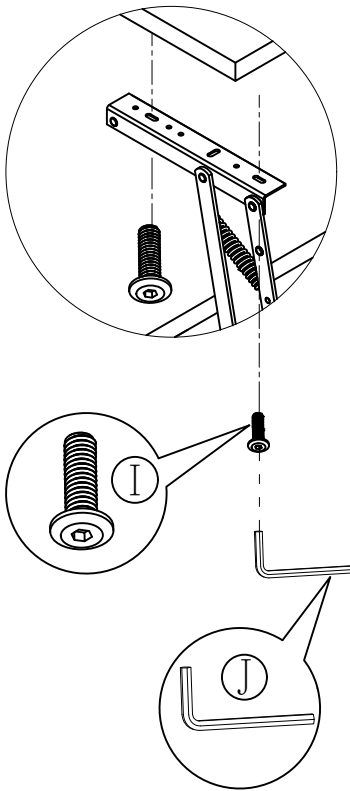

## Step 13

Ⓜ	X1	Ⓜ	X4
			
S=4		M6*12	



Align the hinge side with the end of the small lift mechanism.

## Step 14

Ⓜ	X1
	
S=4	
Ⓜ	X4
	
M6*12	

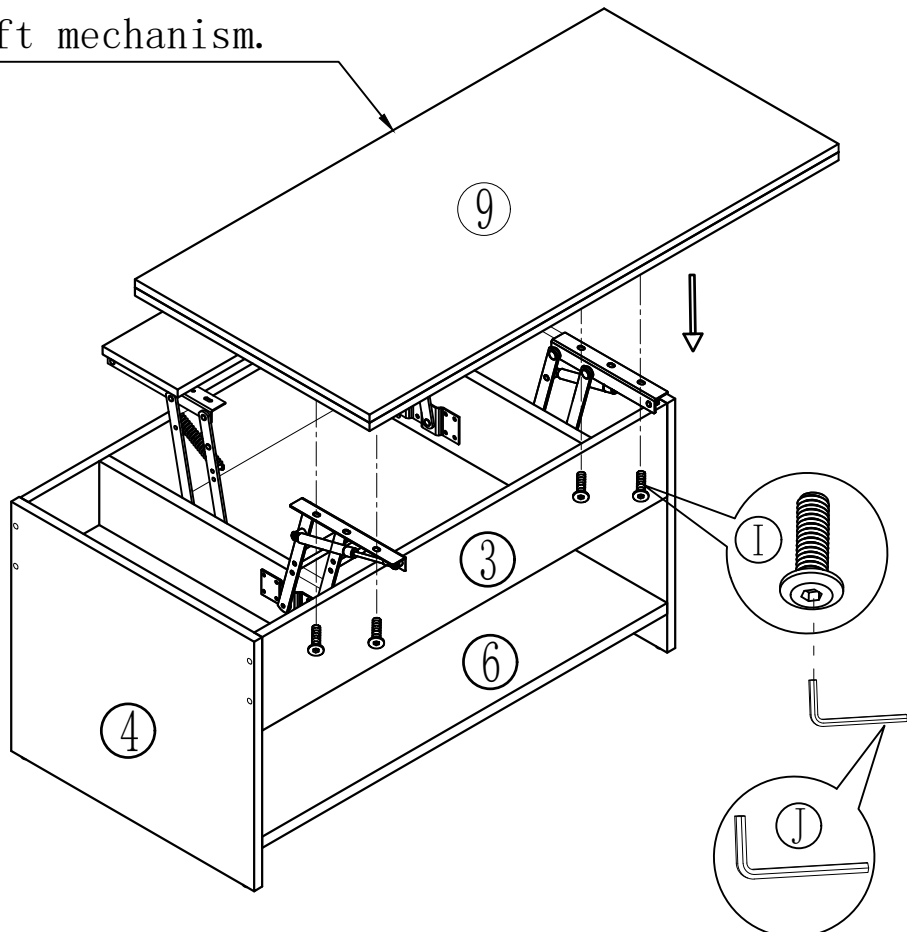

# Use demonstration

①

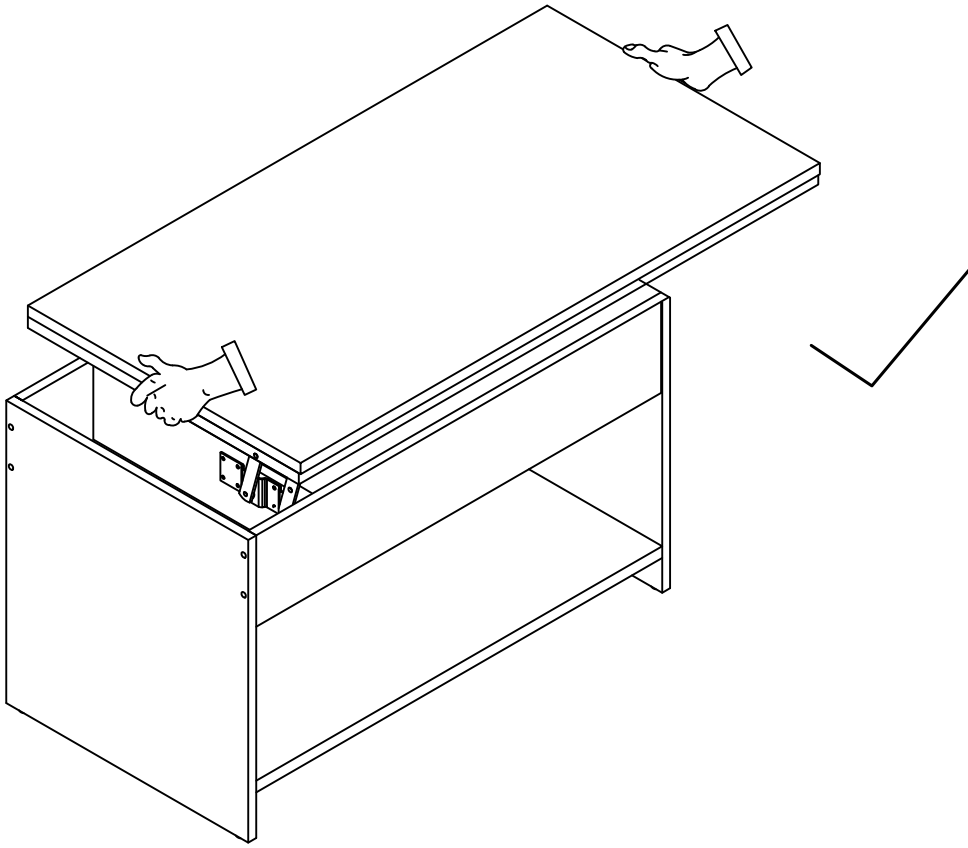

②

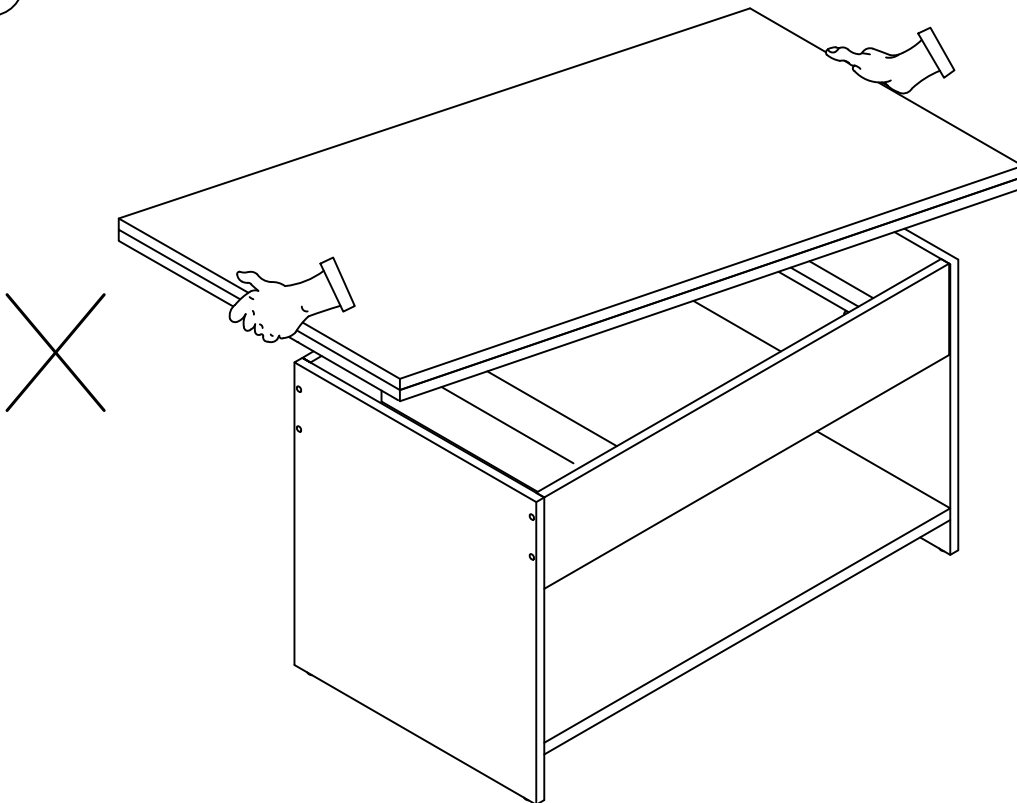

# Use demonstration

③

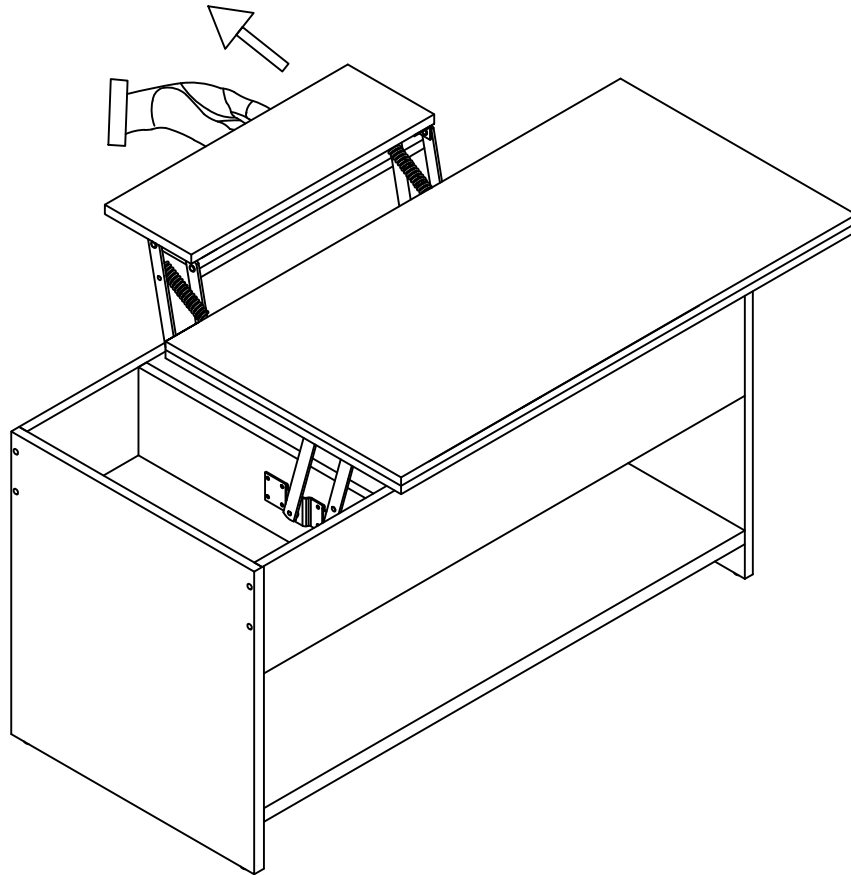

④

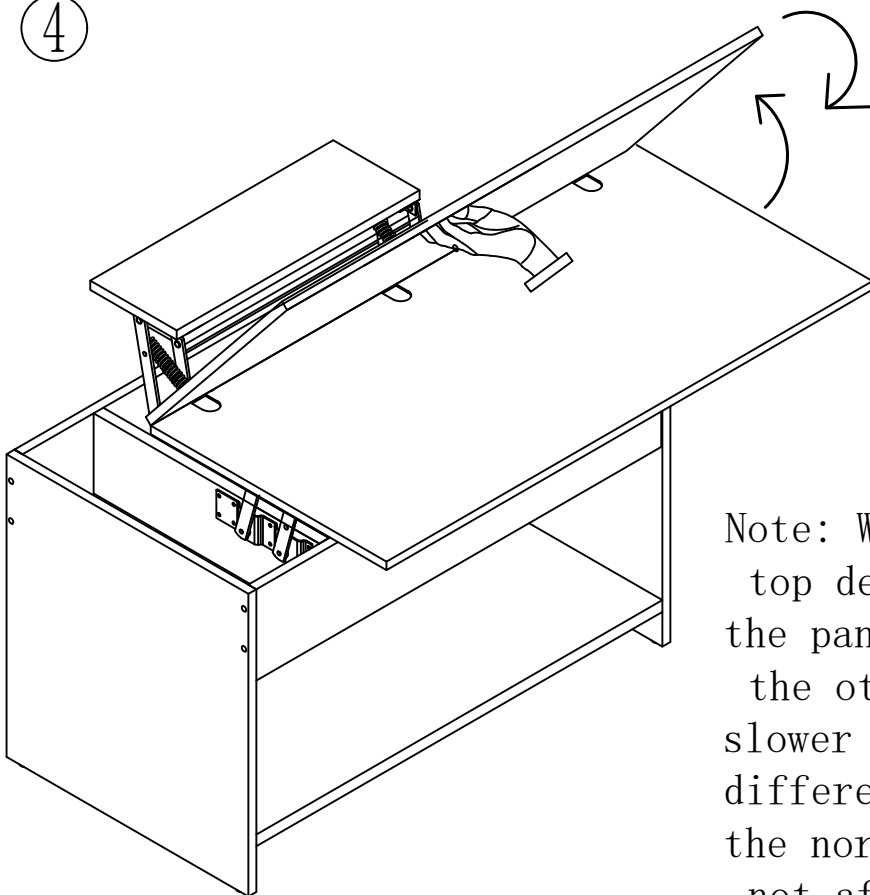

Note: When the coffee table top descends, one end of the panel drops faster while the other drops slightly slower due to air pressure differences. This is within the normal range and will not affect normal use.