

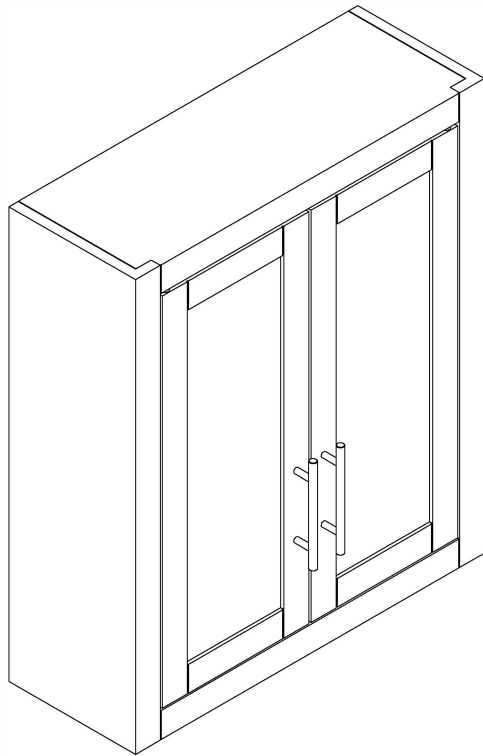

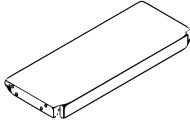

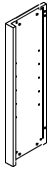

Wall Cabinet

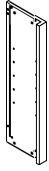
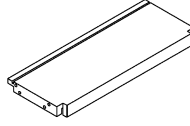

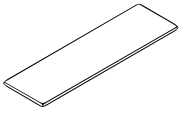
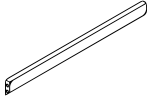
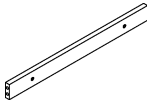
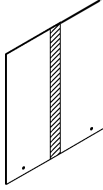
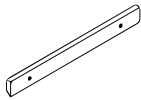
PART LIST

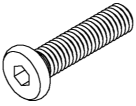
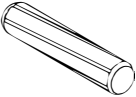
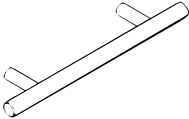
<p>A</p> 	<p>B</p> 	<p>C</p> 	<p>D</p> 	<p>E</p> 
<p>Top Panel 1 PC</p>	<p>Left Panel 1 PC</p>	<p>Right Panel 1 PC</p>	<p>Bottom Panel 1 PC</p>	<p>Left Door 1 PC</p>
<p>F</p> 	<p>G</p> 	<p>H</p> 	<p>I</p> 	<p>J</p> 
<p>Right Door 1 PC</p>	<p>Adjustable Shelf 2 PCS</p>	<p>Upper Rail 1 PC</p>	<p>Lower Rail 1 PC</p>	<p>Back Panel 1 PC</p>
<p>K</p> 				
<p>Support Plate 1 PC</p>				

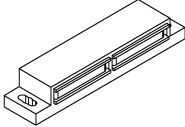
HARDWARE LIST

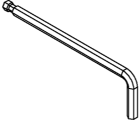
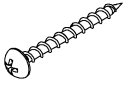
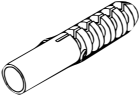
<p>#1</p>  <p>Ø$\frac{1}{4}$" x 1"</p>	<p>#2</p>  <p>Ø8 x 30mm</p>	<p>#3</p> 	<p>#4</p>  <p>Ø4 x 22mm</p>	<p>#5</p> 
<p>Long Bolt 8 PCS</p>	<p>Wood Dowel 16 PCS (Extra 1)</p>	<p>Handle 2 PCS</p>	<p>Short Bolt 4 PCS (Extra 1)</p>	<p>Shelf Holder 8 PCS (Extra 1)</p>
<p>#6</p> 	<p>#7</p>  <p>Ø3 x 15mm</p>	<p>#8</p> 	<p>#9</p>  <p>Ø4 x 38mm</p>	<p>#10</p>  <p>Ø8 x 38mm</p>
<p>Double Magnet 1 PC</p>	<p>Screw 2 PCS</p>	<p>Allen Wrench 1 PC</p>	<p>Long Screw 4 PCS</p>	<p>Wall Anchor 4 PCS</p>

ADDITIONAL TOOLS (Not Provided)

Note: It is not recommended to use power tools during assembly.

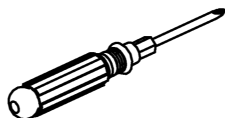



Phillips Head Screwdriver

Note: Wood dowels are intended for alignment. Additional clearance between wood dowel and pre-drilled hole is intentional for ease of assembly.

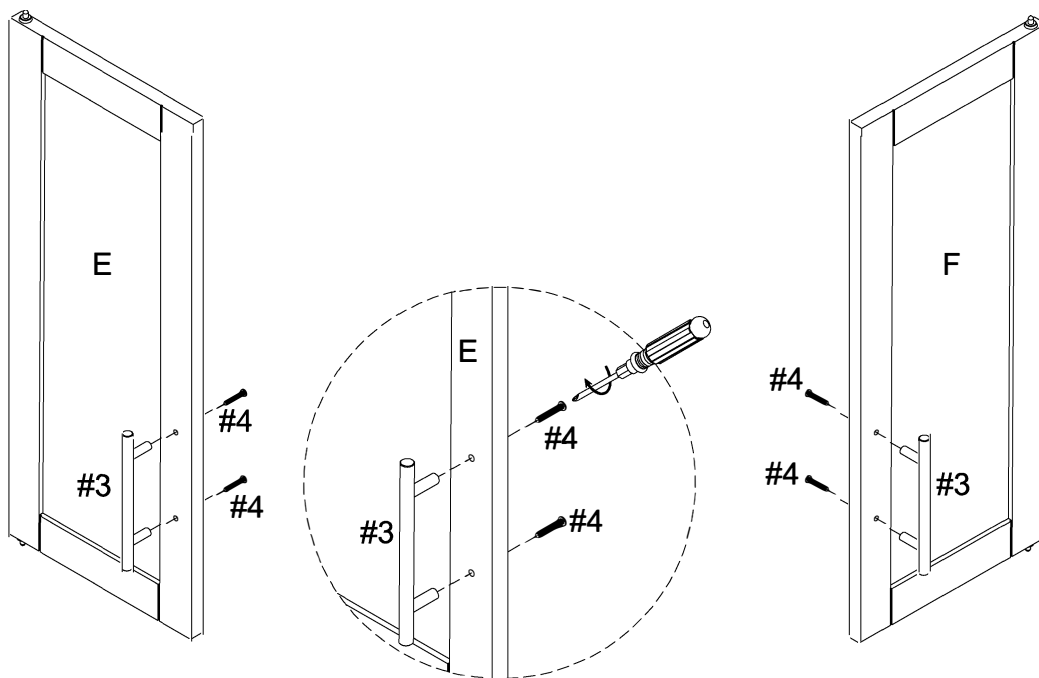

Step 1. Attach handles (part #3) to left door (part E) and right door (part F) using short bolts (part #4) and phillips head screwdriver.

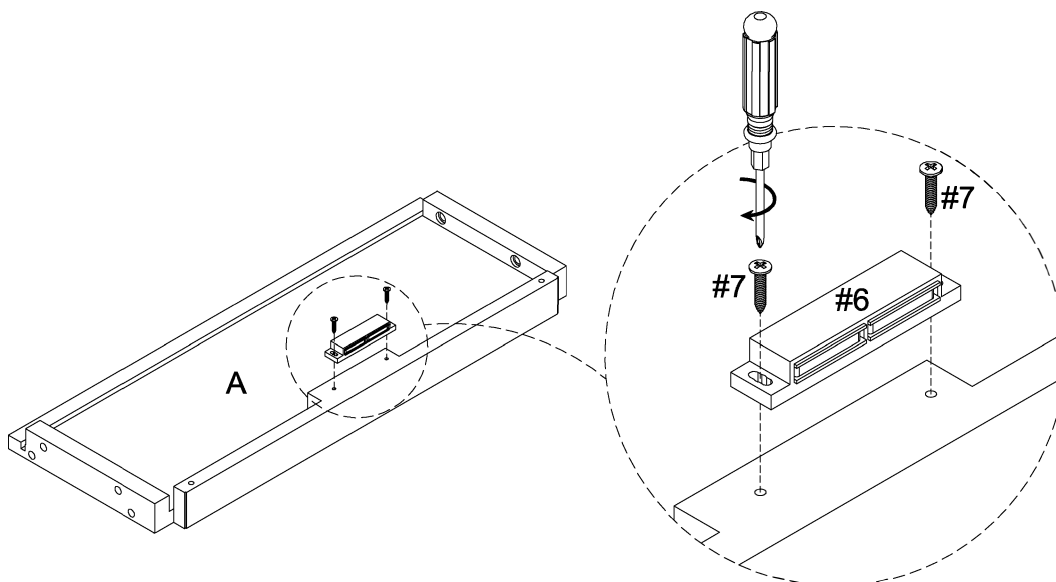

#3  x 2
#4  x 4

Step 2. Attach double magnet (part #6) to top panel (part A) using screws (part #7) and phillips head screwdriver.



#6  x 1
#7  x 2

Step 3. Attach top panel (part A) and bottom panel (part D) to left panel (part B) using wood dowels (part #2), long bolts (part #1) and allen wrench (part #8).

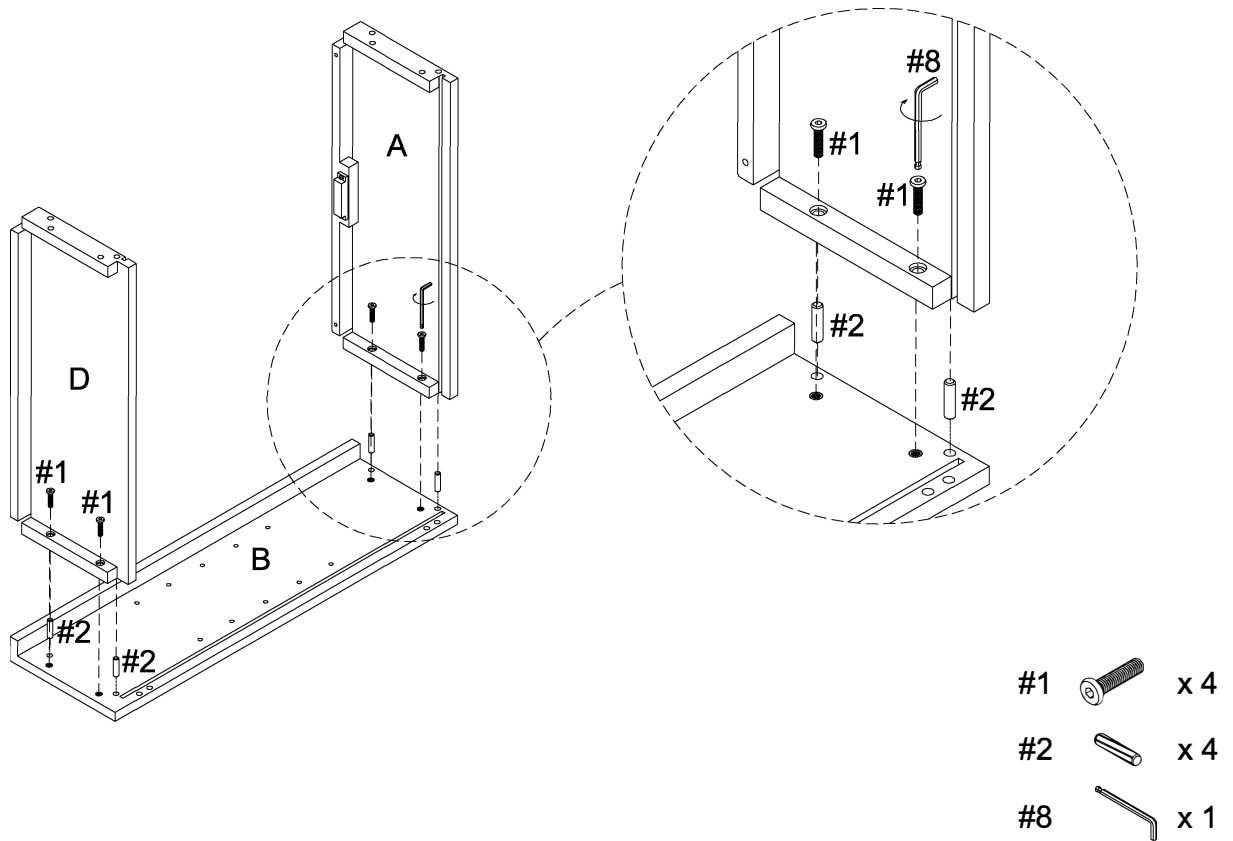

Step 4. Attach upper rail (part H) and lower rail (part I) to left panel (part B) using wood dowels (part #2).

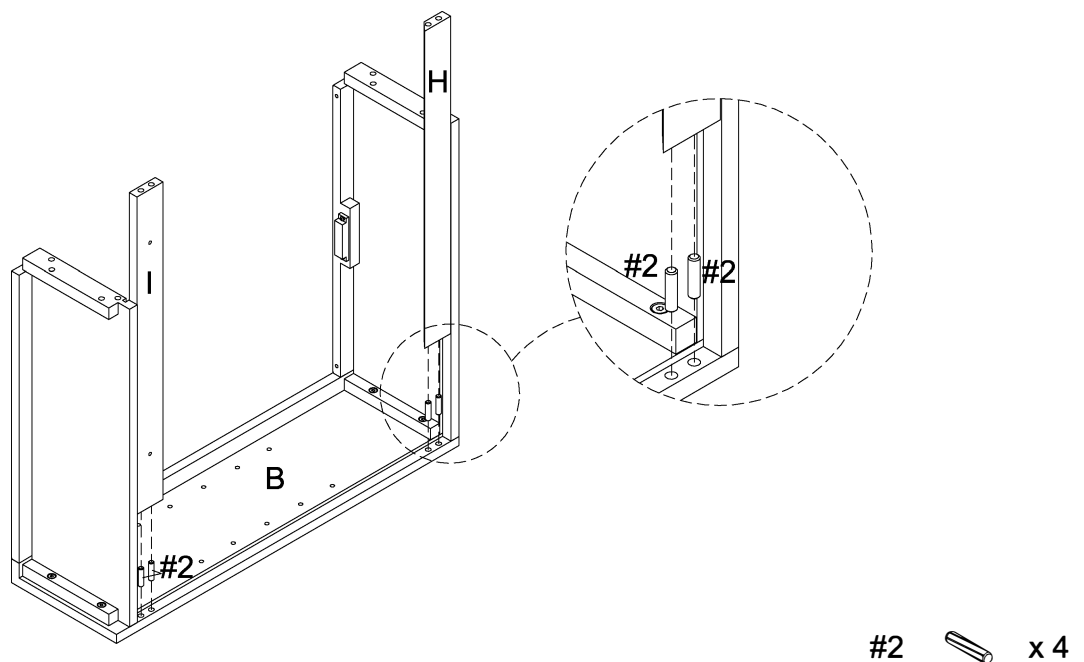

Step 5. Slide back panel (part J) into the grooves of assembled unit (parts A, B & D).

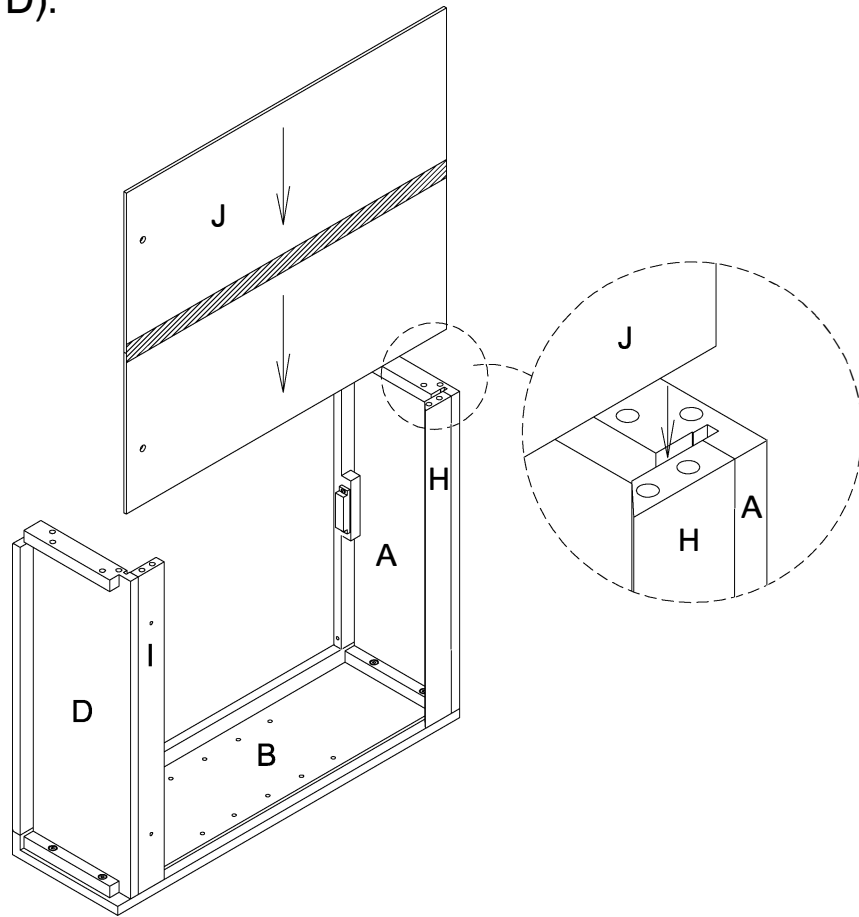

Step 6. Attach right panel (part C) to assembled unit (parts A, D, H, I & J) using wood dowels (part #2), long bolts (part #1) and allen wrench (part #8).

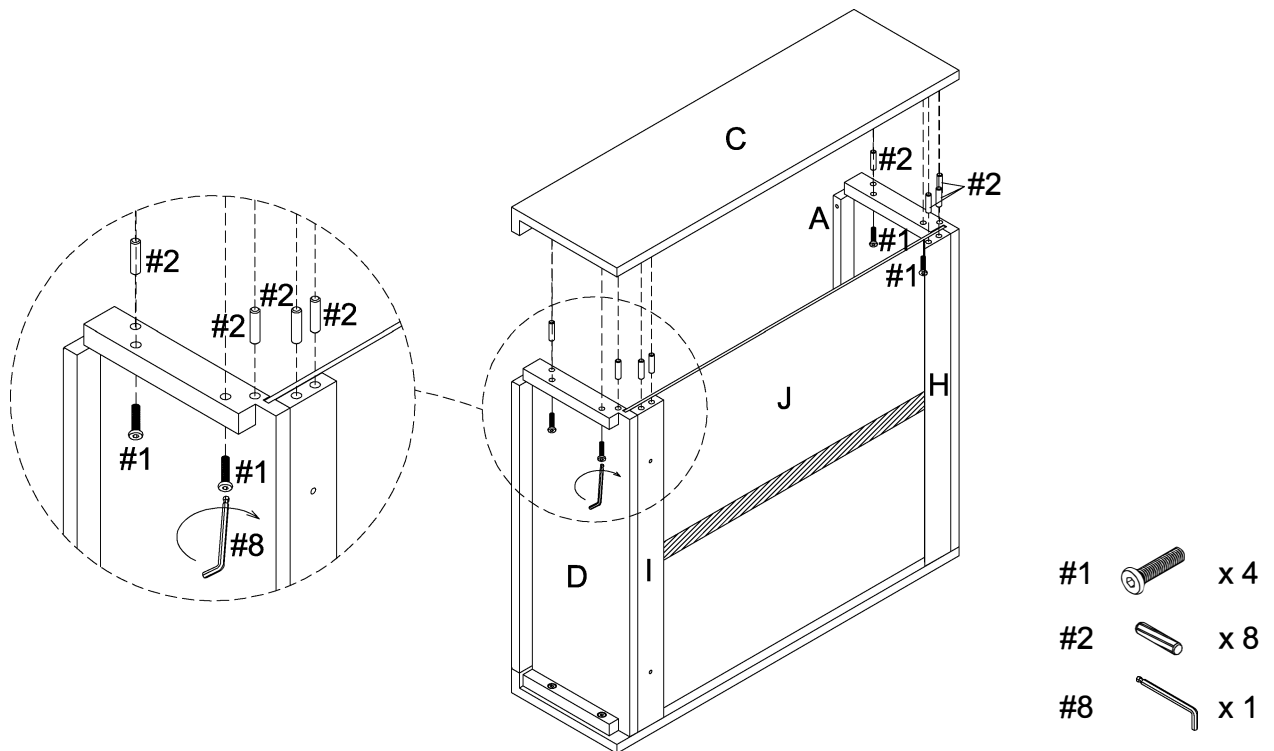

Step 7. Carefully turn the unit upright. Attach doors (parts E & F) by placing bottom pin hinge (pre-installed in door) in the pre-drilled hole of bottom panel (part D), then depress the top spring-loaded pin hinge so it can be placed in the pre-drilled hole of top panel (part A).

Note: Be sure top and bottom pin hinges are fully extended to secure doors in place.

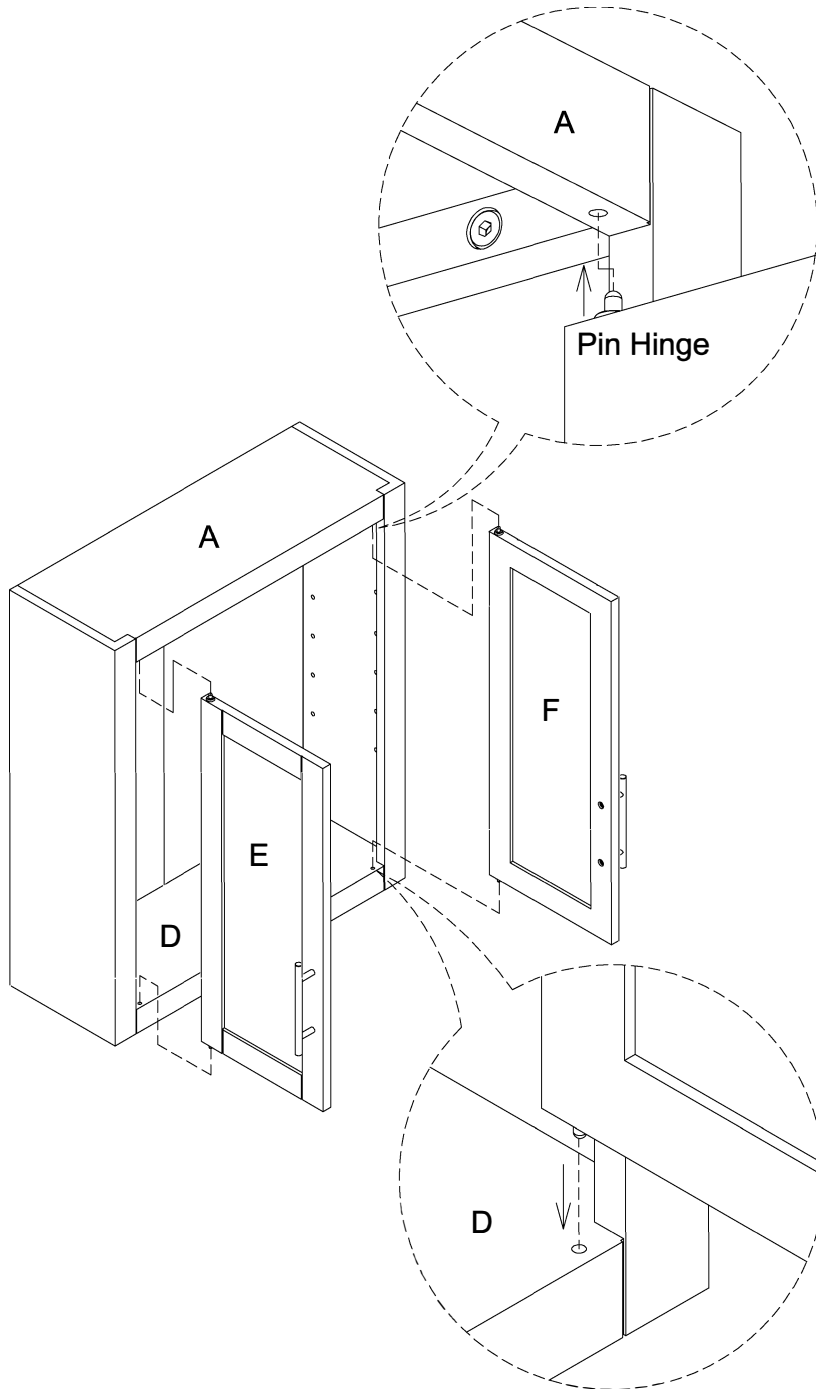

Step 8. Hold support plate (part K) in desired location. Support plate (part K) will be about 2-1/2" lower than the top of assembled unit. Make sure support plate (part K) is level, we recommend using a leveler to ensure it's oriented correctly. Use a pencil to mark the anchor locations using support plate (part K) screw holes as a guide. Drill two 11/32" holes in these marked spots and tap wall anchors (part #10) into the drilled holes. Secure support plate (part K) to wall anchors (part #10) using long screws (part #9) and phillips head screwdriver. Mount assembled unit onto support plate (part K). Upper rail (part H) has a recessed area that will hook onto support plate (part K). Use a pencil to mark the 2nd set of anchor locations using assembled unit screw holes as a guide. Remove assembled unit and drill two 11/32" holes in these marked spots and tap wall anchors (part #10) into the drilled holes. Remount assembled unit and secure it to wall anchors (part #10) using long screws (part #9) and phillips head screwdriver.

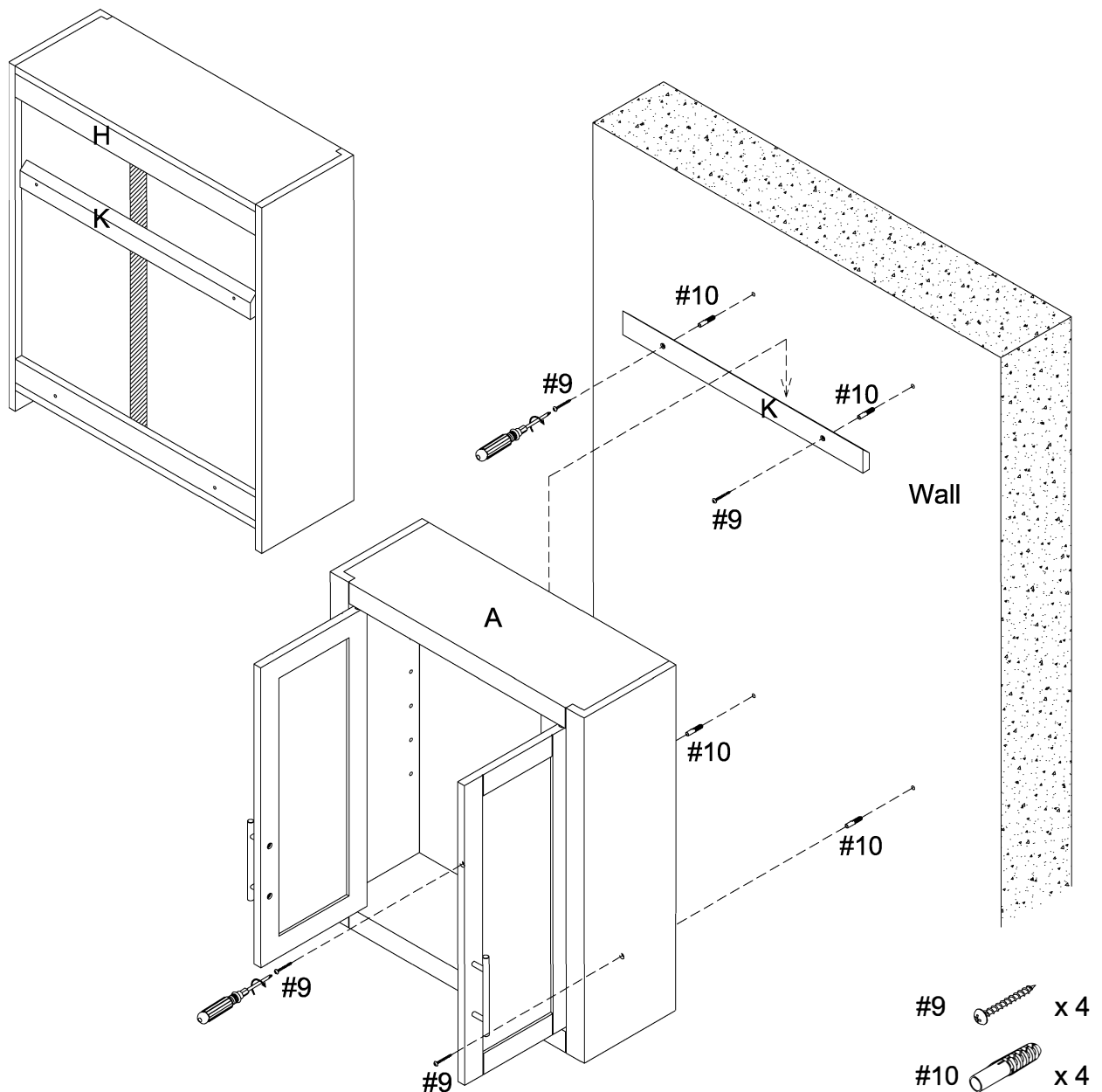

Step 9. Place shelf holders (part #5) into desired position and slide adjustable shelves (part G) into place.

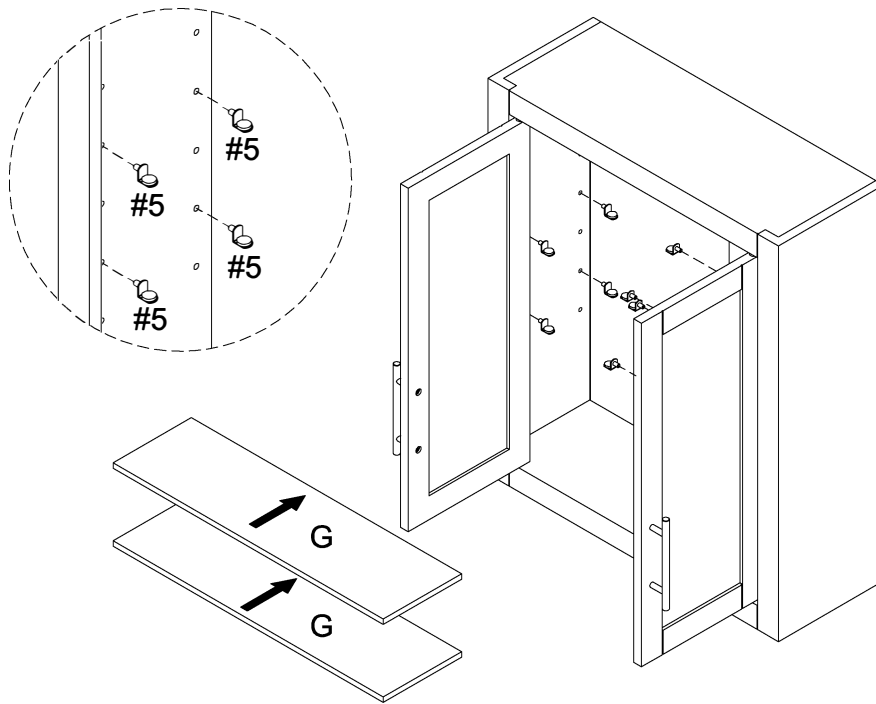

#5  x 8

