

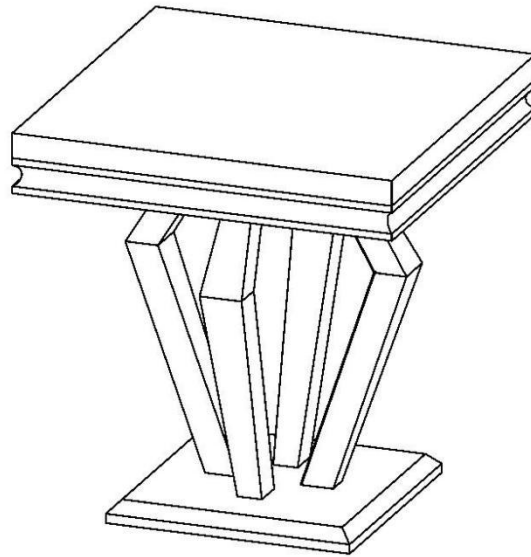

# Assembly Instruction

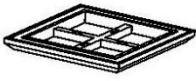

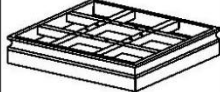



**ASSEMBLY TIME PER UNIT: 20 MINUTES**

## PARTS IDENTIFICATION

<b>A</b>	<b>BASE</b>		<b>1PC</b>	<b>B</b>	<b>TOP</b>		<b>1PC</b>
<b>C</b>	<b>LEGS</b>		<b>4PCS</b>				

## HARDWARE LIST

NO.	SIZE	DIAGRAM	QTY	NO.	SIZE	DIAGRAM	QTY
1	Allen wrench		1	3	Bolts M8x16		8
2	Bolts M8x40		8	4	Flat washer		16

STEP1

tighten all the screws to 90%.

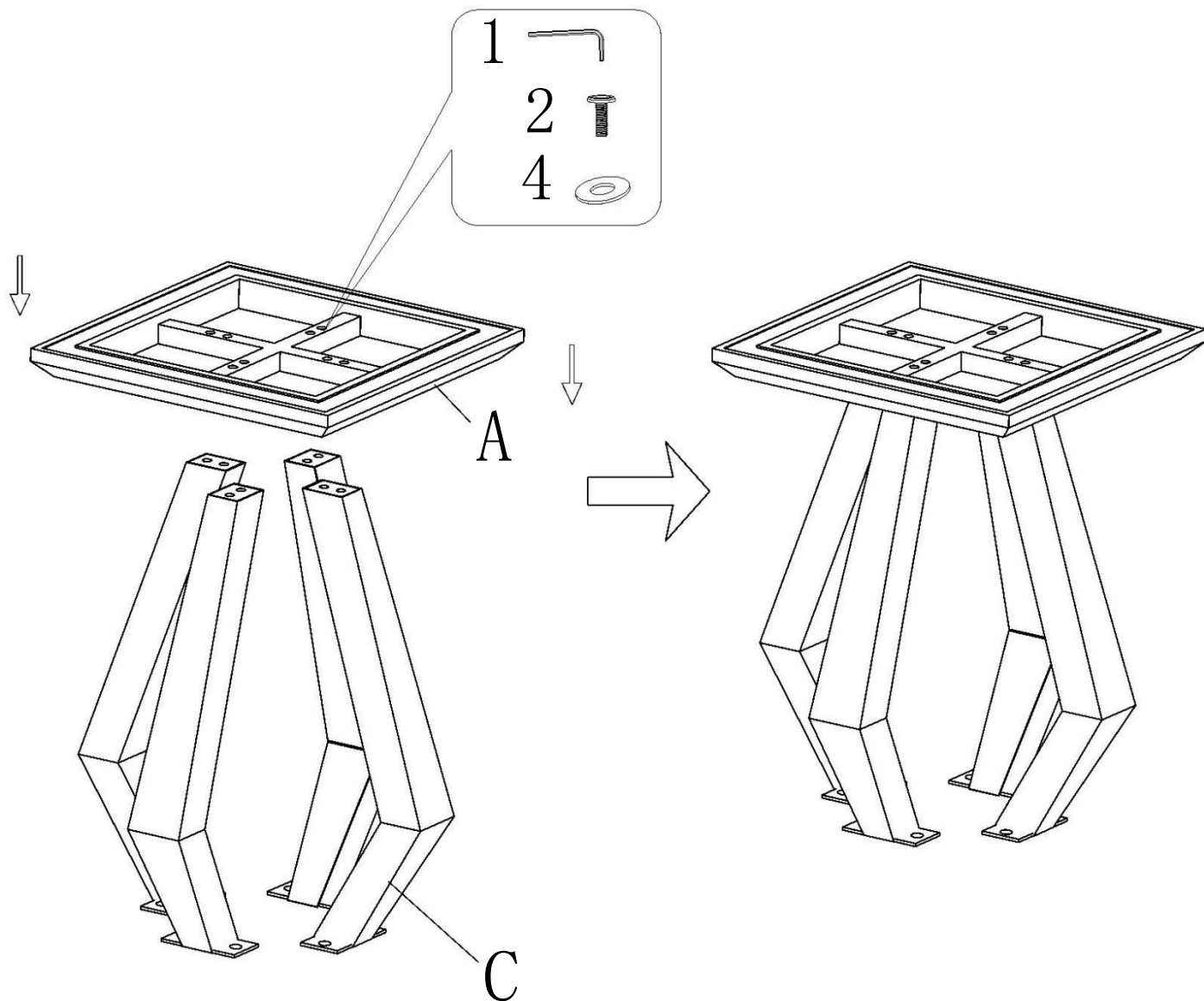

STEP2

tighten all the screws to 90%.

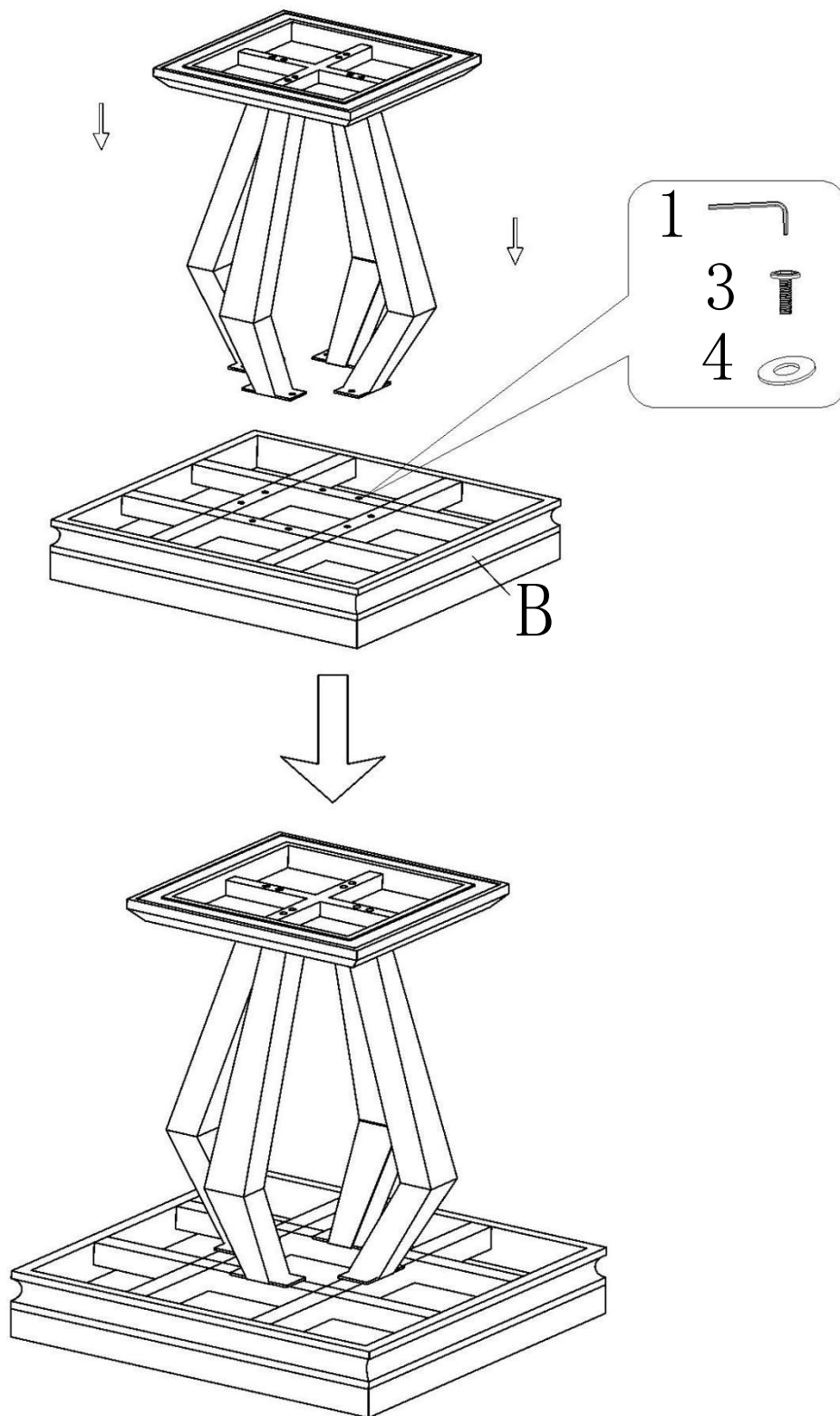

STEP3

tighten all the screws to 100%.

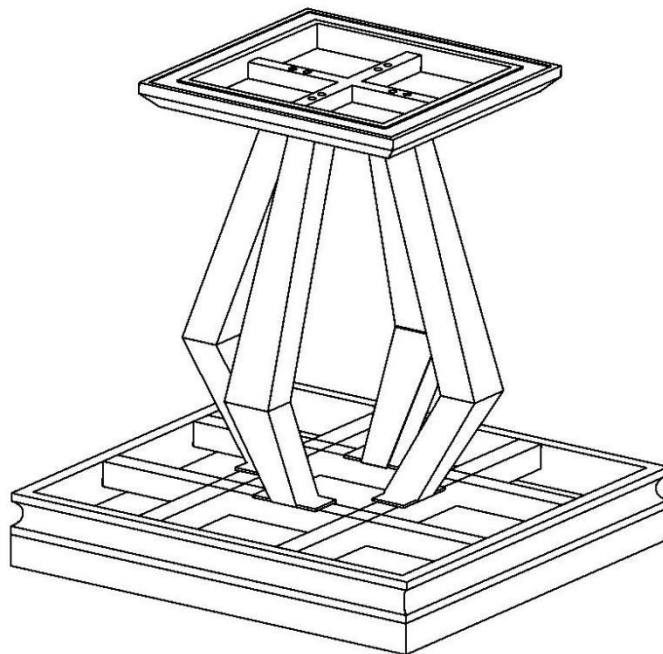

COMPLETED

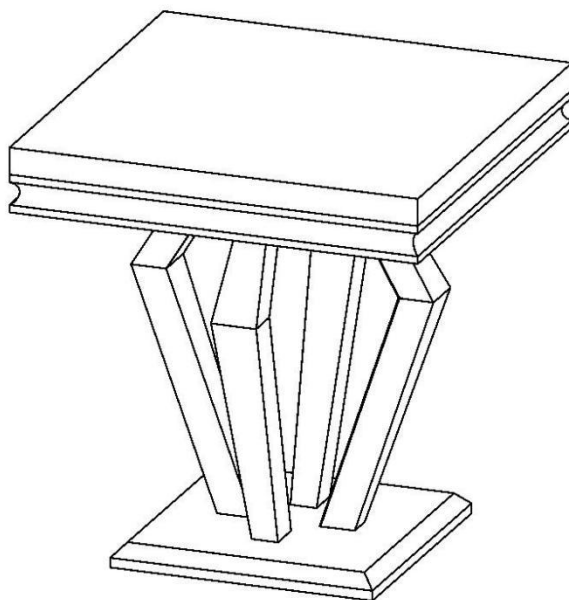

THE BOTTOM FIXED ADJUSTMENT FEETS