

# **ASSEMBLY INSTRUCTION/ INSTRUCTION DE MONTAGE**

## **RATTAN SOFA SET/ SALON DE JARDIN**

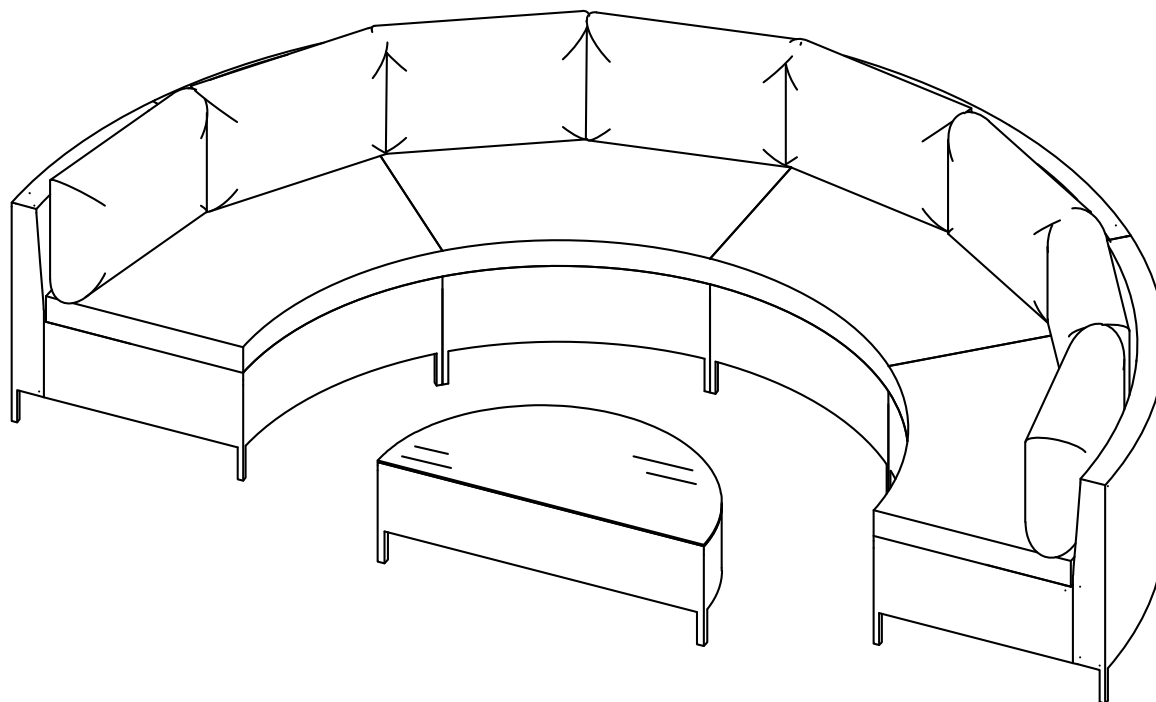

### **Notice/Avis**

- 1. 50% Tighten before fixings all screws, Allen wrench is recommended instead of an electric drill./ Serrez à 50 % avant de fixer toutes les vis, Une clé Allen est recommandée plutôt qu'une perceuse électrique.**
- 2. Place the item on a flat ground to adjust and make sure it remains stable./Placez l'objet sur un sol plat pour l'ajuster et assurez-vous qu'il reste stable.**
- 3. Tighten up all screws with tools gradually./ Serrez progressivement toutes les vis avec des outils.**

**4. If the screws are not aligned with holes during assembly, please loosen all the other screws to 50% and continue the assembly process./**

**Si les vis ne sont pas alignées avec les trous pendant l'assemblage, desserrez toutes les autres vis à 50 % et poursuivez le processus d'assemblage.**

**5. If the item is not stable, please loosen all the screws, adjust it on a flat ground and tighten up all screws again./**



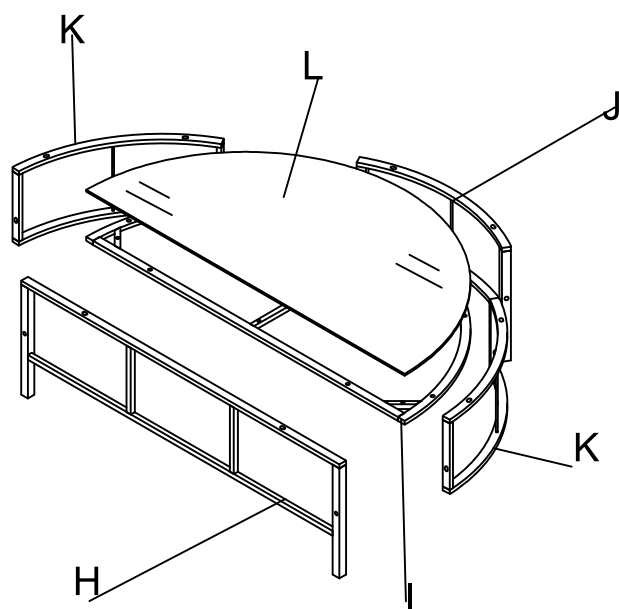
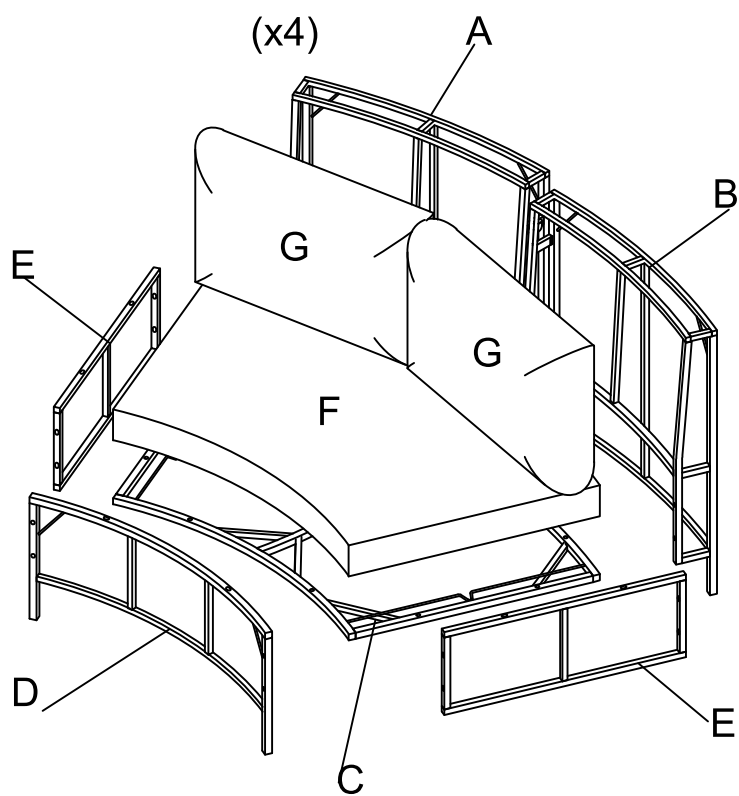

**Si l'article n'est pas stable, desserrez toutes les vis, ajustez-le sur un sol plat et resserrez toutes les vis.**

**6. Note: If one or more screws are fully tightened during assembly, chances are the others will not be aligned with holes. In addition, all the holes are designed to be relatively larger to provide more space for the adjustment of the screws./**

**Remarque : si une ou plusieurs vis sont serrées à fond pendant l'assemblage, il est probable que les autres ne soient pas alignées avec les trous. De plus, tous les trous sont conçus pour être relativement plus grands afin de fournir plus d'espace pour le réglage des vis.**

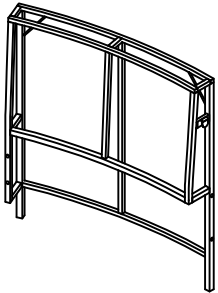
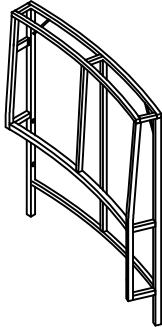
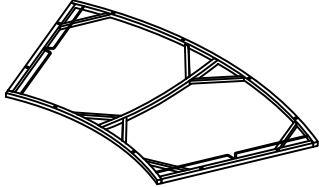
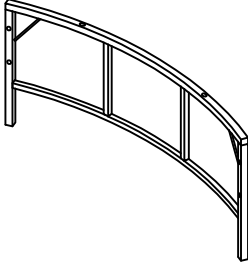
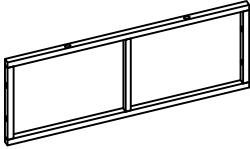
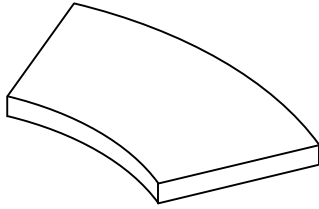
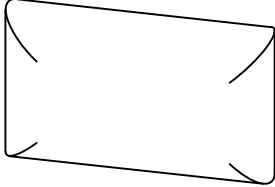
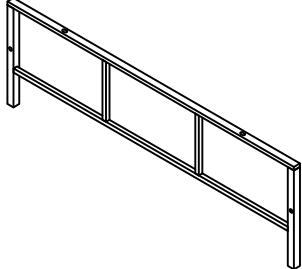
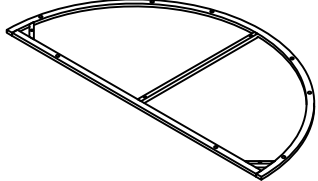
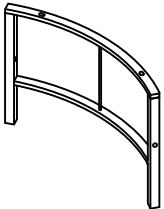
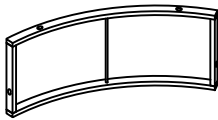
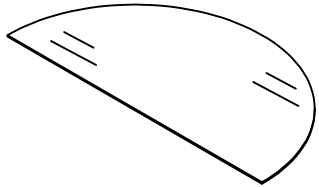
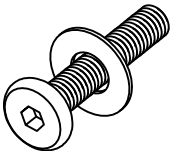
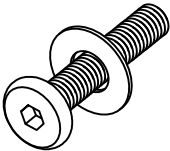

**PART LIST/LISTE DES PIÈCES**

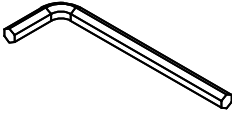
<p><b>A</b></p>  <p>4 pcs</p>	<p><b>B</b></p>  <p>4 pcs</p>	<p><b>C</b></p>  <p>4 pcs</p>			
<p><b>D</b></p>  <p>4 pcs</p>	<p><b>E</b></p>  <p>8 pcs</p>	<p><b>F</b></p>  <p>4 pcs</p>			
<p><b>G</b></p>  <p>8 pcs</p>	<p><b>H</b></p>  <p>1 pc</p>	<p><b>I</b></p>  <p>1 pc</p>			
<p><b>J</b></p>  <p>1 pc</p>	<p><b>K</b></p>  <p>2 pcs</p>	<p><b>L</b></p>  <p>1 pc</p>			
<p><b>1</b></p>  <p><b>Bolt M6x35 mm/ Boulon M6x35 mm (64 pcs)+extra 3 pcs</b></p>	<p><b>2</b></p>  <p><b>Bolt M6x30mm/ Boulon M6x30 mm (12 pcs)+extra 2 pcs</b></p>	<p><b>3</b></p>  <p><b>Bolt M6x20 mm/ Boulon M6x20 mm (32 pcs)+extra 3 pcs</b></p>	<p><b>4</b></p>  <p><b>16 pcs</b></p>	<p><b>5</b></p>  <p><b>Plastic connector/ Connecteur en plastique (6 pcs)</b></p>	<p><b>6</b></p>  <p><b>Allen key M4/ Clé à molette (2 pcs)</b></p>

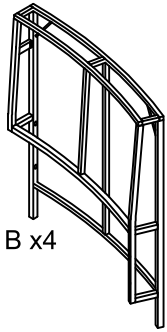

B x4

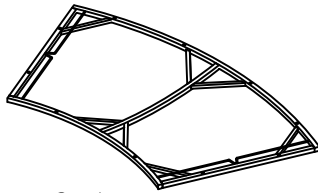

C x1

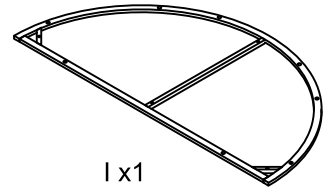

I x1

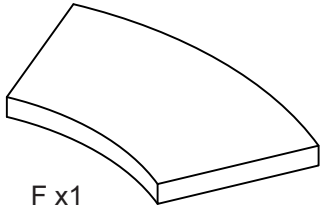

F x1

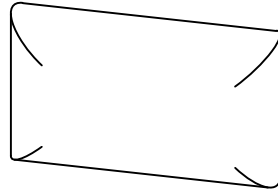

G x4

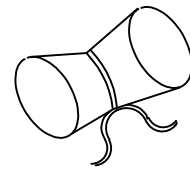

**HARDWARE/  
MATÉRIEL**

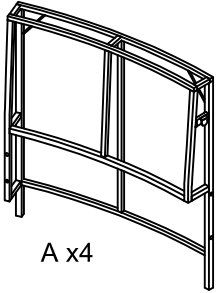

A x4

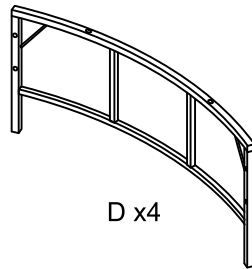

D x4

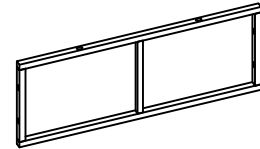

E x8

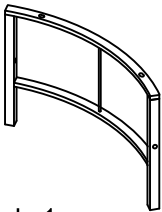

J x1

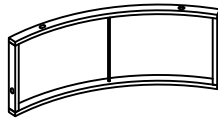

K x2

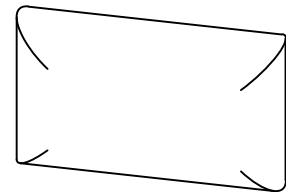

G x4

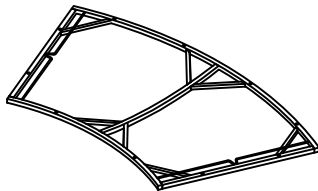

C x3

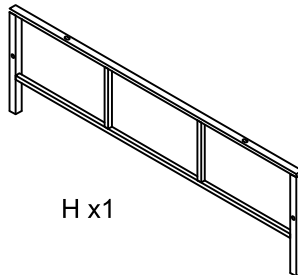

H x1

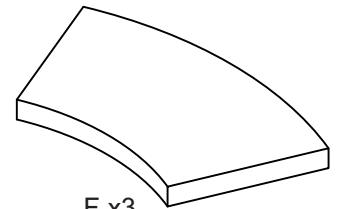

F x3

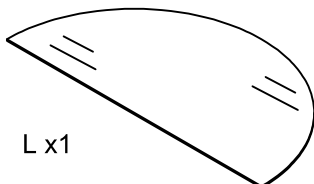

L x1

STEP 1/Étape 1 x4

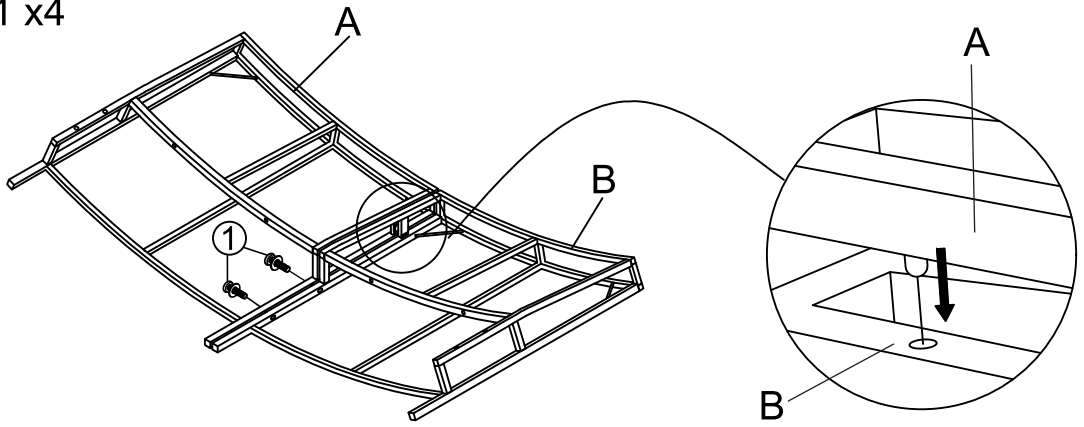

① x2

STEP 2/Étape 2 x4

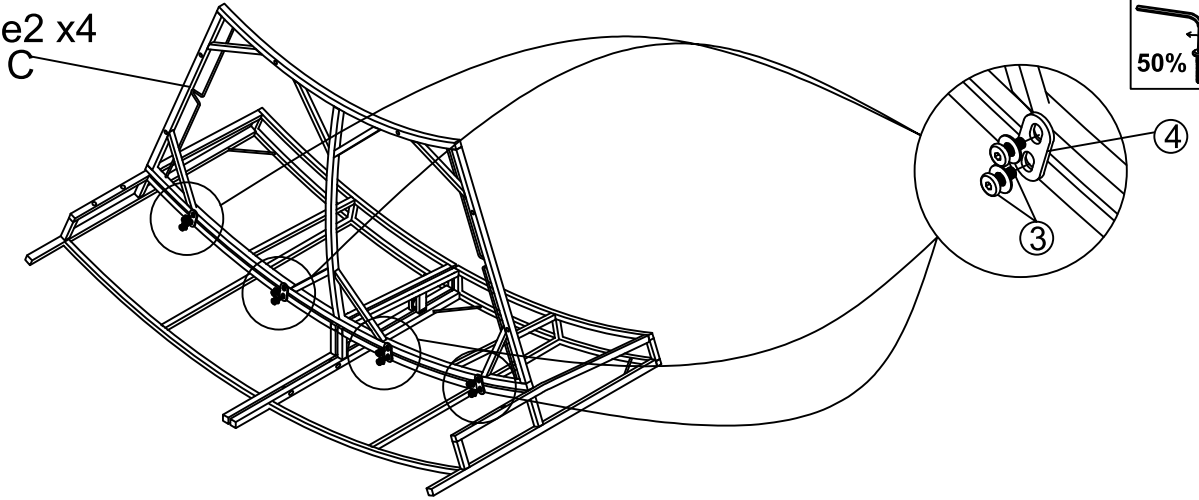

③ x8 ④ x4

STEP 3/Étape 3 x4

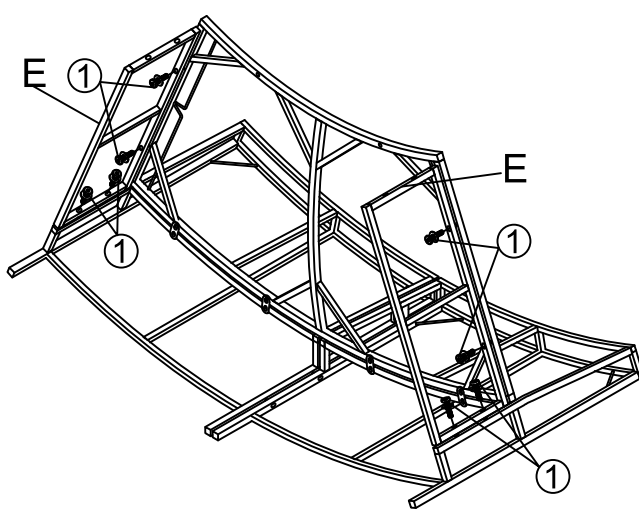

① x8

STEP 4/Étape 4 x4

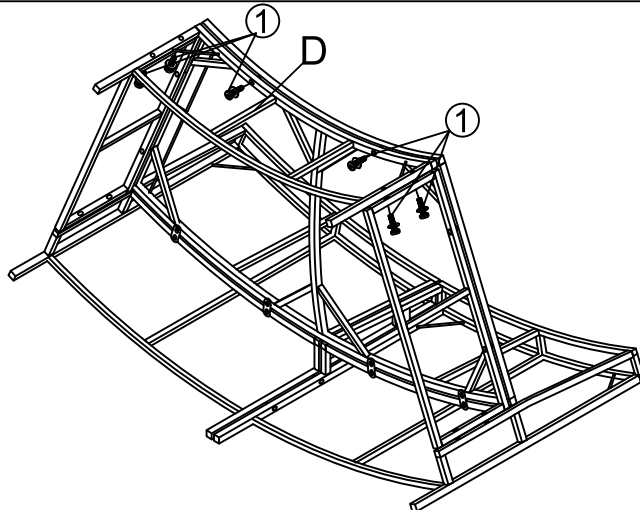

① x6

STEP 5/Étape 5 x4

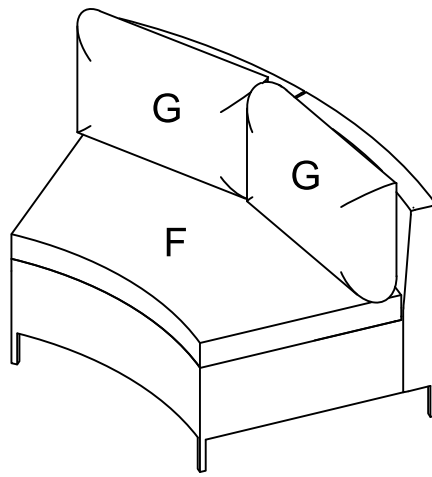

STEP 6/Étape 6

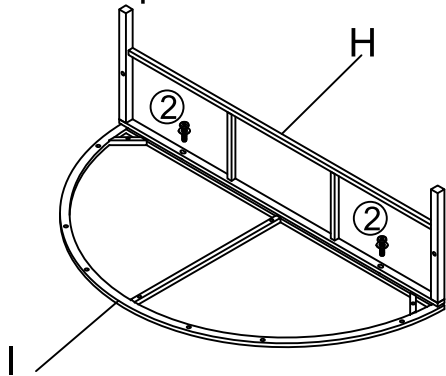

STEP 7/Étape 7

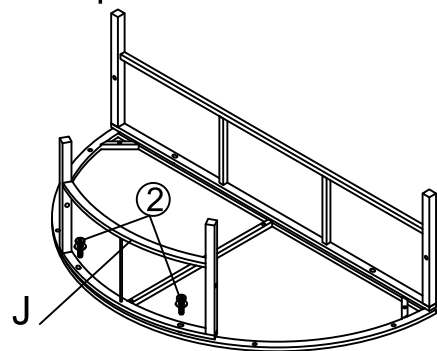

② x2

② x2

STEP 8/Étape 8

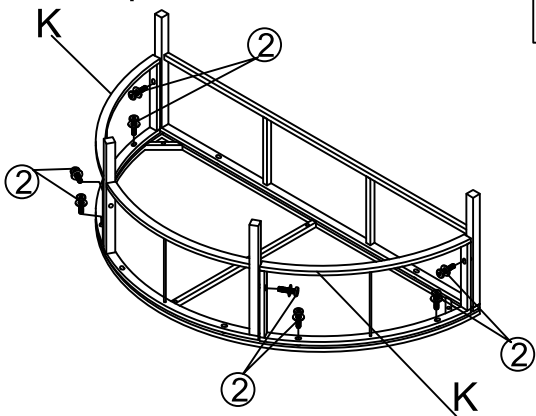

STEP 9/Étape 9

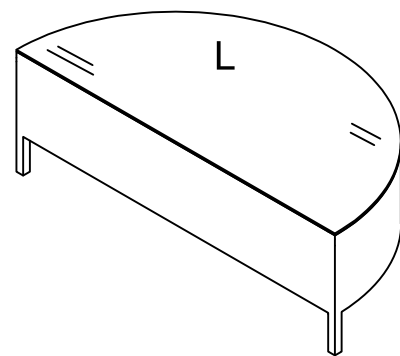

② x8

STEP 10/Étape 10

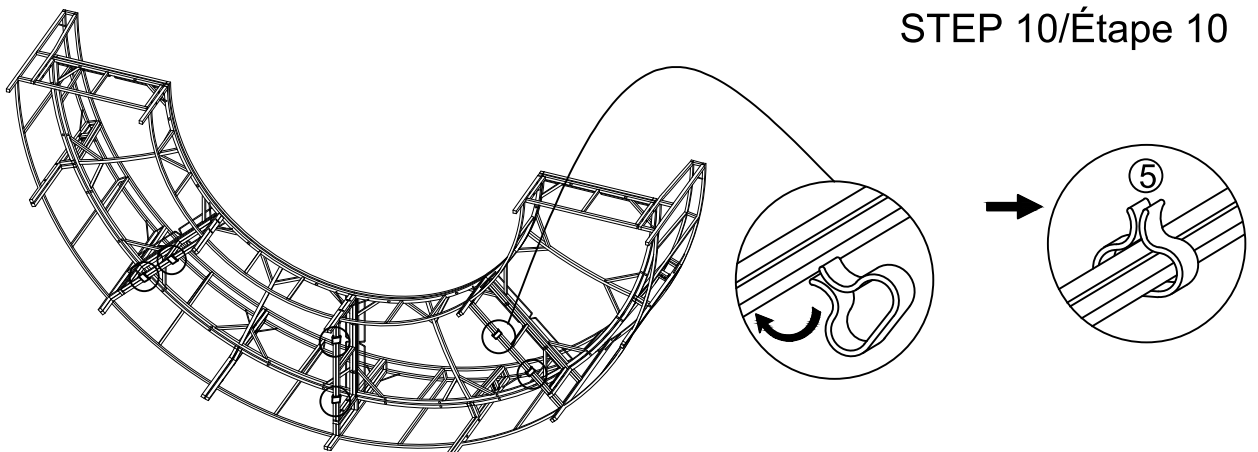

⑤ x6

STEP 11/Étape 11

