



20 : 00

estimated
assembly time



2 or more

people required

- For solid wood product : please refer to the pages from 4-13
- For oak veneer product : please refer to the pages from 14-20

Ok, let's
get started!



- Put on mood music!
- To prevent damage to product, use the clean side of package carton or rug as working surface.
- In the event of missing or damaged parts, delivery problems etc., please reach out to our team.
We will be happy to fix the problem!

care guide

- Clean regularly with a soft and dry cloth.
- To protect finish, avoid use of abrasive cleaners.
- Wipe up spills immediately. Please!

ⓘ **While assembling the product, tighten the bolts up to 50%. Once all parts are in place, only then fully tighten the bolts.**



product parts

■ For solid wood product : please refer to the pages from 4-13



A
Cabinet Case
x1



B
Left Metal Leg
x1

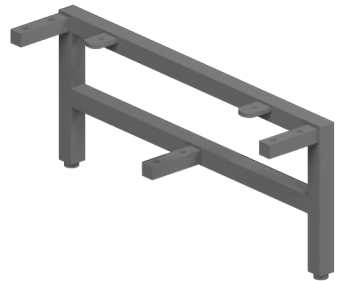

B
Right Metal Leg
x1



C
Center Metal Leg
x1
4

what's included



(D) - Flat Washer
($\text{\O}20\text{mm}$ x $\text{\O}8\text{mm}$)
x4



(G) - Bolts
(M6 x 10mm)
x12



(E) - Lock Washer
($\text{\O}15\text{mm}$ x $\text{\O}8\text{mm}$)
x4

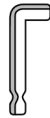

(H) - Allen Key
($\text{\O}4\text{mm}$ x $\text{\O}110\text{mm}$)
x1



(F) - Bolts
(M6 x 20mm)
x8



(I) - Handle
x2

assembly instructions

Friendly Tip: Take a deep breath going in. This may be a tricky part, but nothing too overwhelming. Just follow these steps to the T and the outcome will be worth it!



- ⓘ While assembling the product, tighten the bolts up to 50%. Once all parts are in place, only then fully tighten the bolts.

step 1:

Start by turning the cabinet case (A) upside-down. Unscrew the preinstalled metal rods (using Allen Key (H)) on the cabinet case by 50%. See the highlighted areas below for point reference

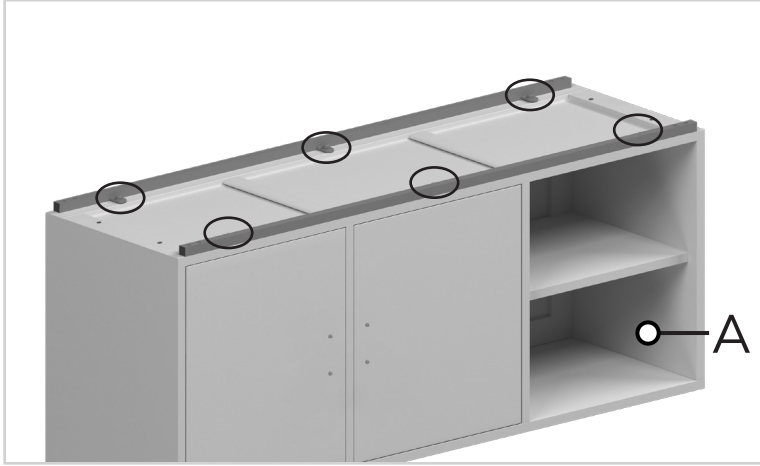

step 2:

Now, insert the left metal leg (B left) into the metal rods on the cabinet case. See this image for reference.

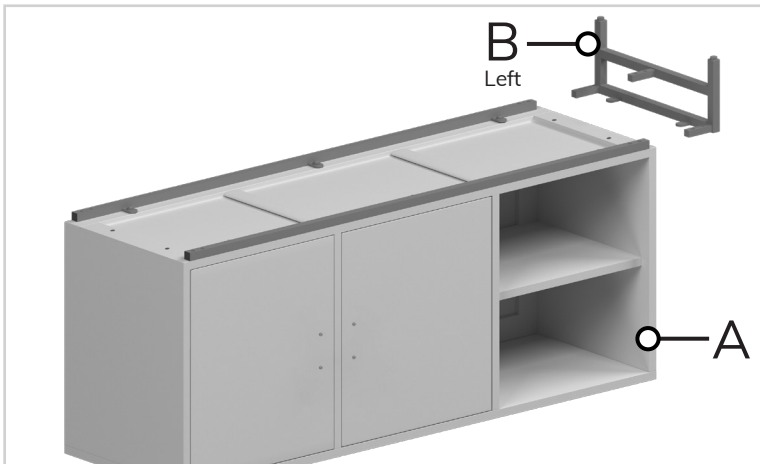

■ For solid wood product : please refer to the pages from 4-13

step 3:

Next, insert the central metal leg (C) into the middle slot on the left metal leg (B left).

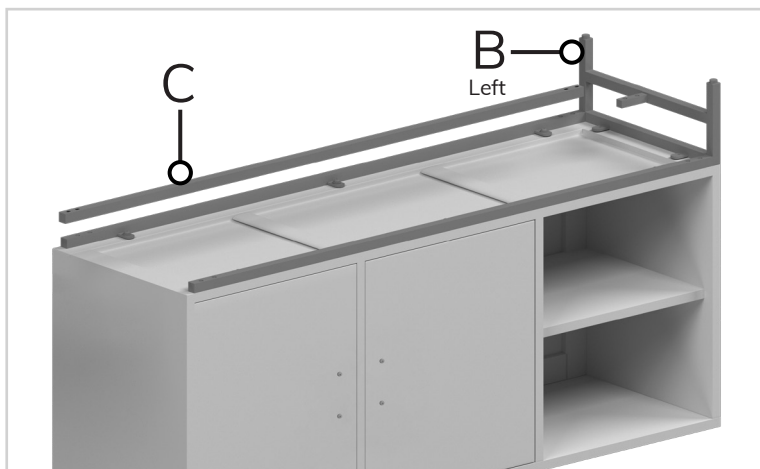

step 4:

Now, take the right metal leg (B right) and insert it into the central metal leg (C) and the metal rods on the cabinet case.

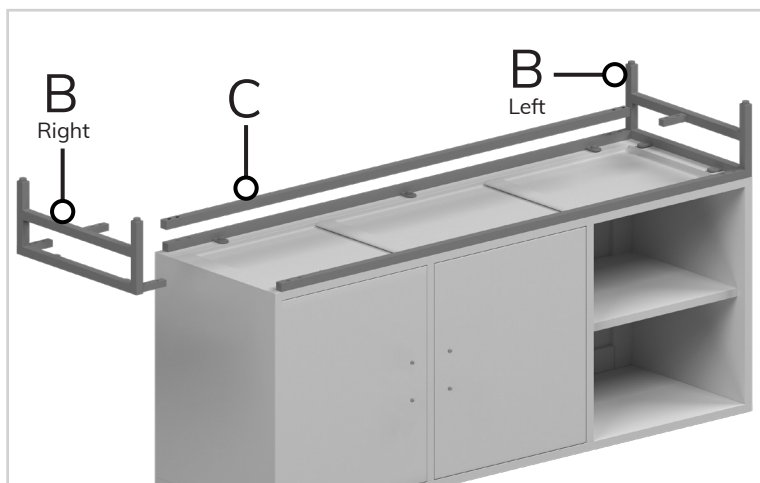

■ For solid wood product : please refer to the pages from 4-13

step 5:

Once the metal base is complete, it's time to secure it in place. See the highlighted areas to know where to tighten the bolts (F).



step 6:

To fix the cabinet case (A) to metal legs (B left and right) use bolts (F), lock washer (E), and flat washer (D) (in the order D, E, F from bottom to top) and insert them into the pre-drilled holes. Tighten all points using the allen key (H).

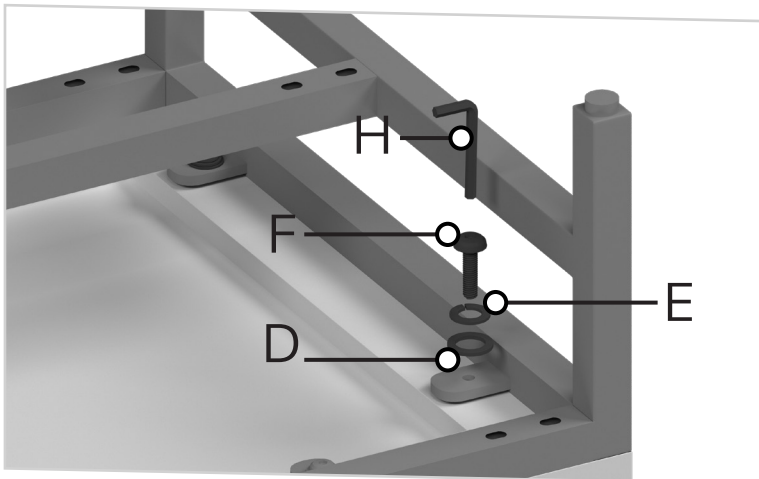

■ For solid wood product : please refer to the pages from 4-13

step 7:

Next, to secure the entire metal base together, see the highlighted areas below to know where to tighten the bolts (G).

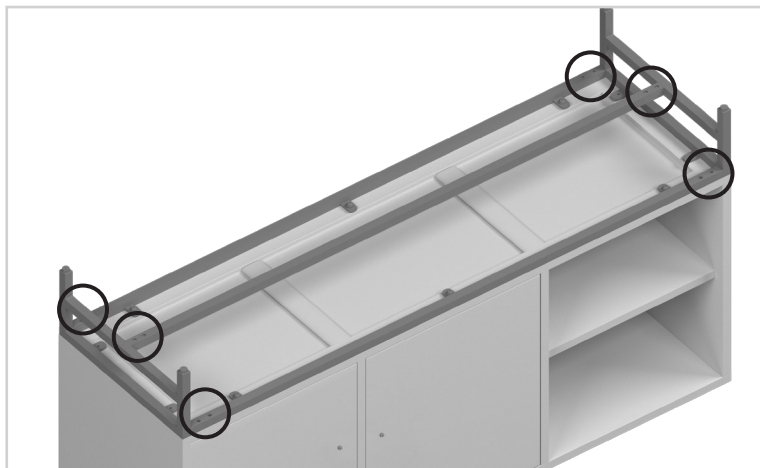

step 8:

Insert bolts (G) on all points and tighten them using the allen-key (H). Make sure all the bolts are 100% tightened.

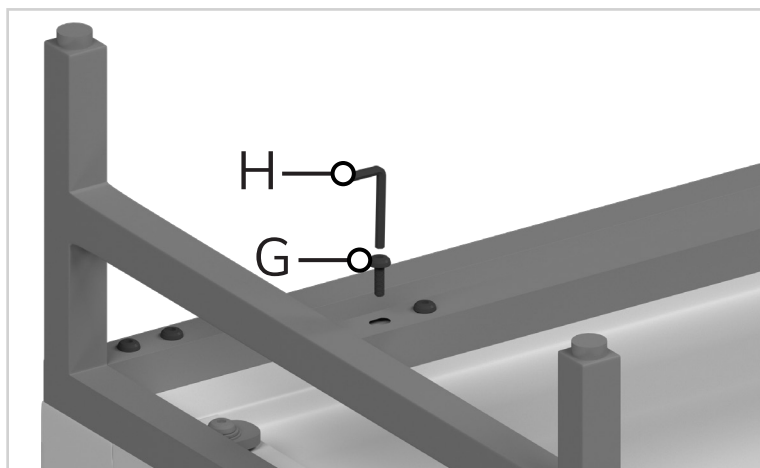

■ For solid wood product : please refer to the pages from 4-13

step 9:

Now turn the cabinet upside-down and pull on the ribbons to open the doors.



step 10:

Then, place the handle (I) outside the doors and attach it using the bolts (F). Tighten it in place using allen key (H).



■ For solid wood product : please refer to the pages from 4-13

Note: If the door does not appear square or aligned, loosen or tighten the appropriate screws on each case hinge as shown in images.

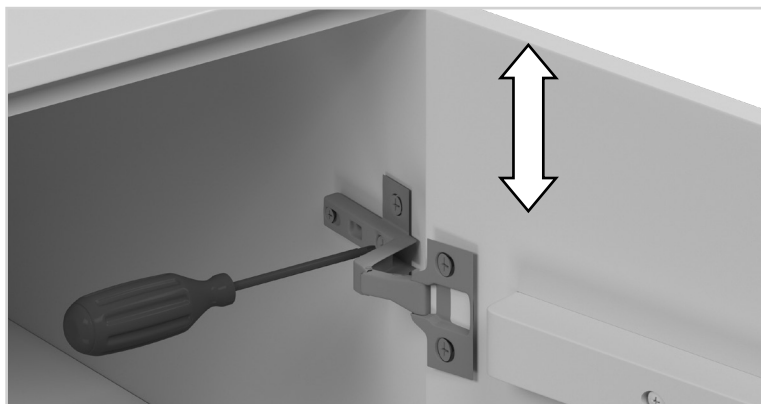
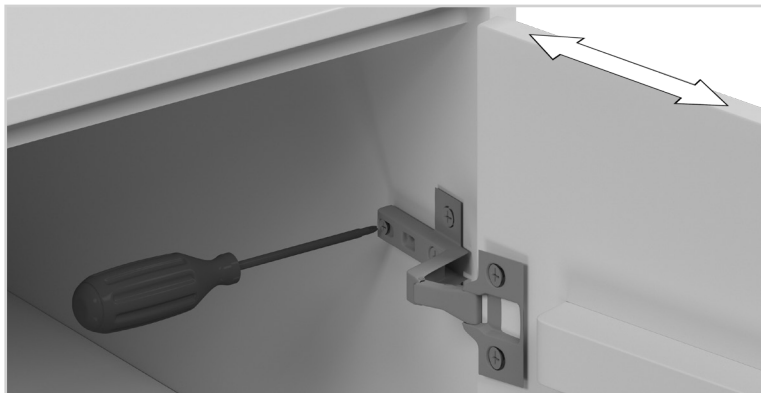

■ For solid wood product : please refer to the pages from 4-13

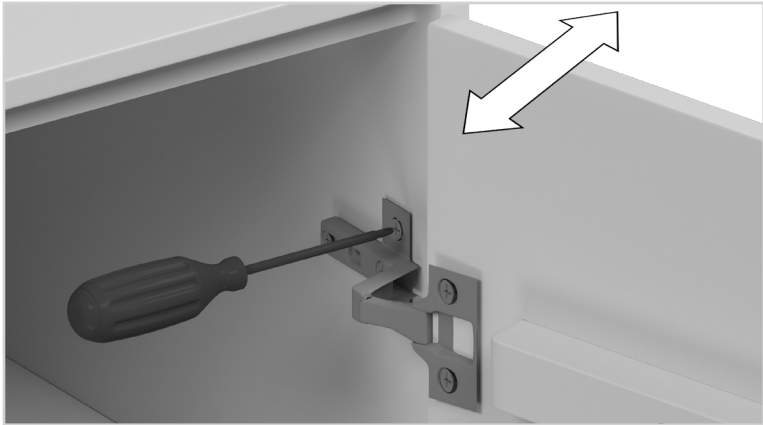

Voila! Your media unit is now assembled and secure!

what's included

■ For oak veneer product : please refer to the pages from 14-20



(D) - Flat Washer
(Ø18mm x Ø8mm)
x4



(G) - Bolts
(M6 x 10mm)
x12



(E) - Lock Washer
(Ø15mm x Ø8mm)
x4



(H) - Allen Key
(Ø4mm x Ø110mm)
x1



(F) - Bolts
(M6 x 20mm)
x8



(I) - Handle
x2

step 1:

Start by turning the cabinet case (A) upside-down. Unscrew the preinstalled metal rods (using Allen Key (H)) on the cabinet case by 50%. See the highlighted areas below for point reference

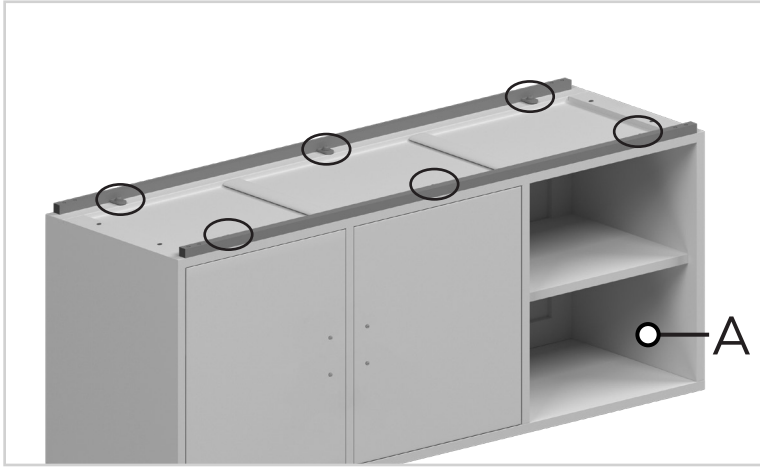

step 2:

Now, insert the left metal leg (B left) into the metal rods on the cabinet case. See this image for reference.

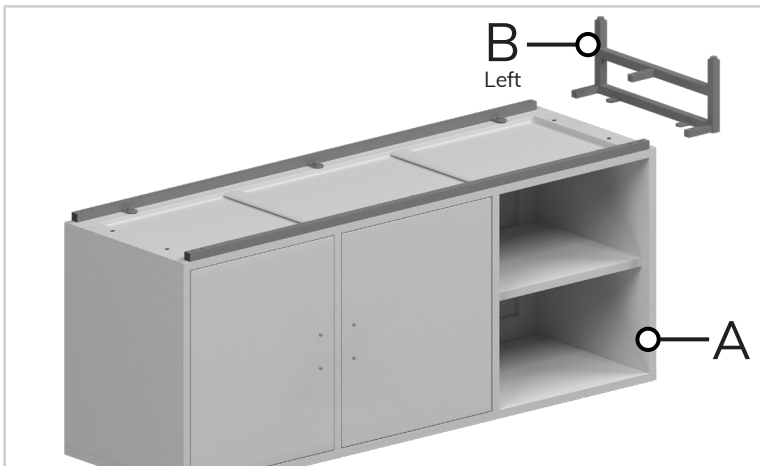

■ For oak veneer product : please refer to the pages from 14-20

step 3:

Next, insert the central metal leg (C) into the middle slot on the left metal leg (B left).

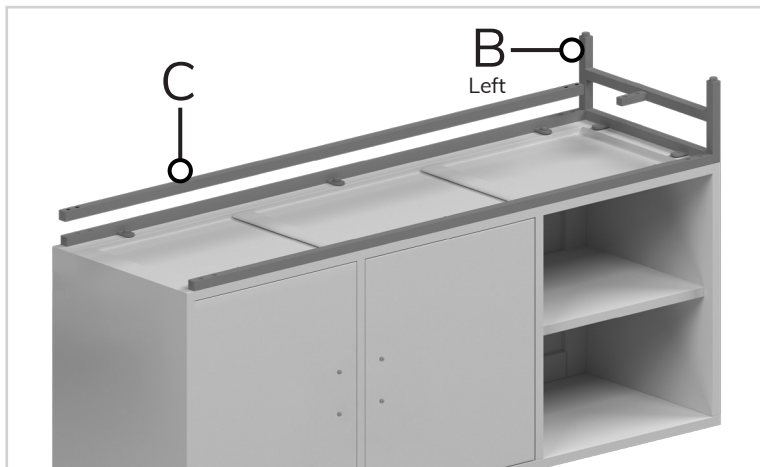

step 4:

Now, take the right metal leg (B right) and insert it into the central metal leg (C) and the metal rods on the cabinet case.

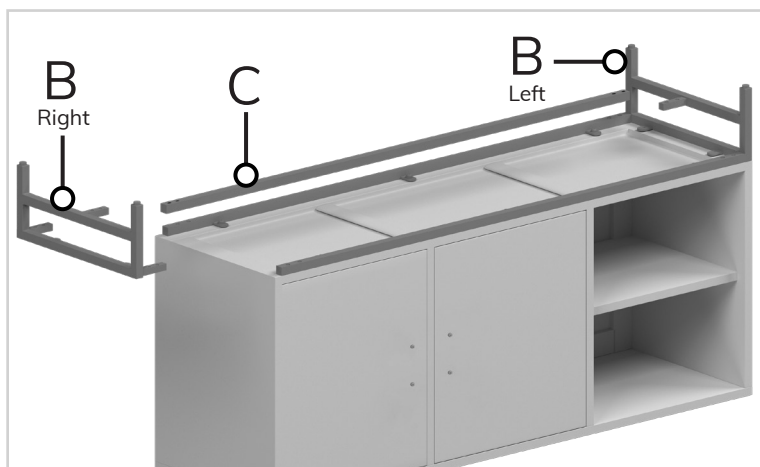

■ For oak veneer product : please refer to the pages from 14-20

step 5:

Once the metal base is complete, it's time to secure it in place. See the highlighted areas to know where to tighten the bolts (F).



step 6:

To fix the cabinet case (A) to metal legs (B left and right) use bolts (F), lock washer (E), and flat washer (D) (in the order D, E, F from bottom to top) and insert them into the pre-drilled holes. Tighten all points using the allen key (H).

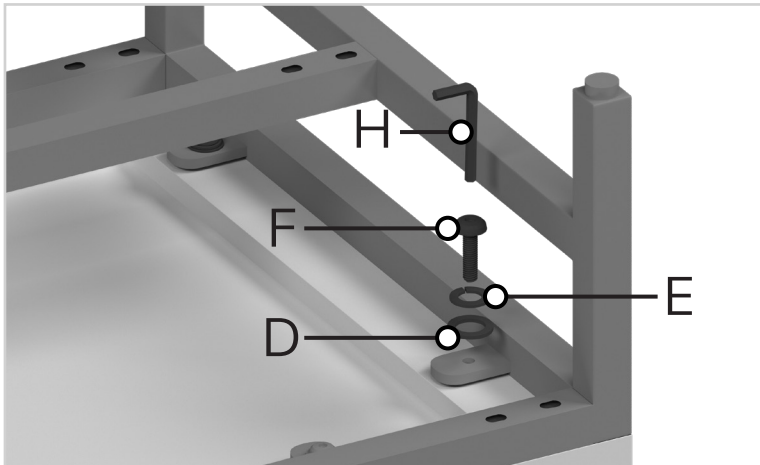

■ For oak veneer product : please refer to the pages from 14-20

step 7:

Next, to secure the entire metal base together, see the highlighted areas below to know where to tighten the bolts (G).

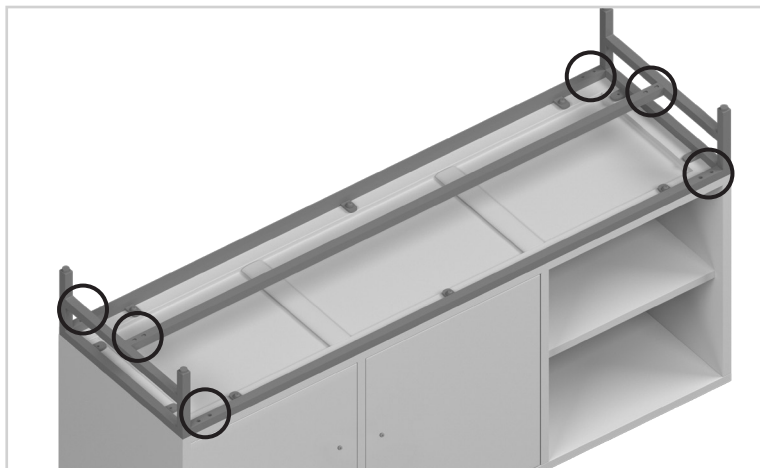

step 8:

Insert bolts (G) on all points and tighten them using the allen-key (H). Make sure all the bolts are 100% tightened.

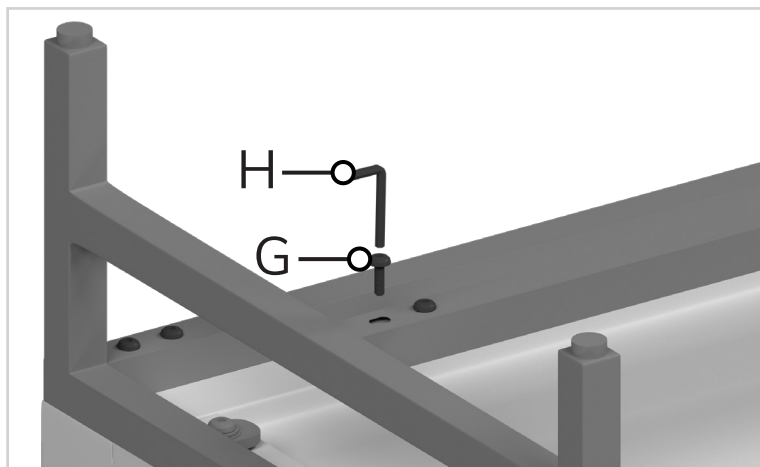

■ For oak veneer product : please refer to the pages from 14-20

step 9:

Now turn the cabinet upside-down and pull on the ribbons to open the doors.



step 10:

Then, place the handle (I) outside the doors and attach it using the bolts (F). Tighten it in place using allen key (H).



■ For oak veneer product : please refer to the pages from 14-20

Note: If the door does not appear square or aligned, loosen or tighten the appropriate screws on each case hinge as shown in images.

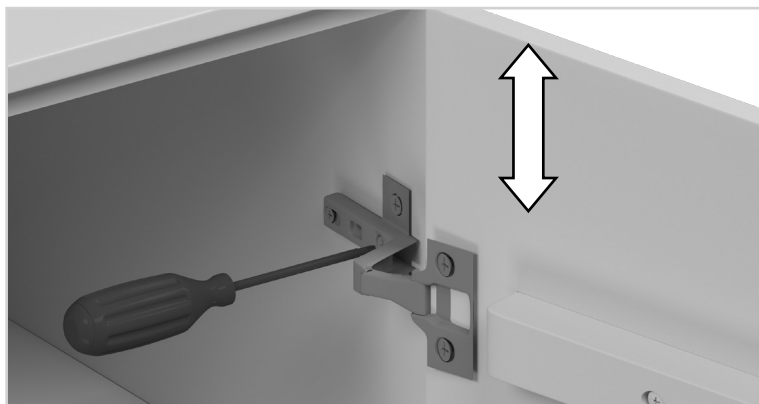
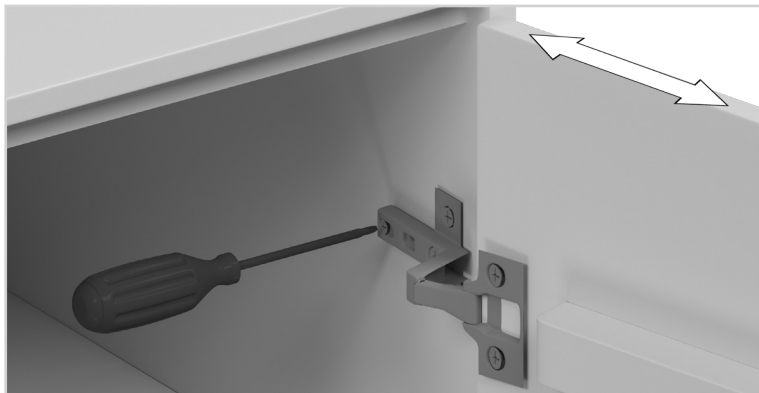

■ For oak veneer product : please refer to the pages from 14-20

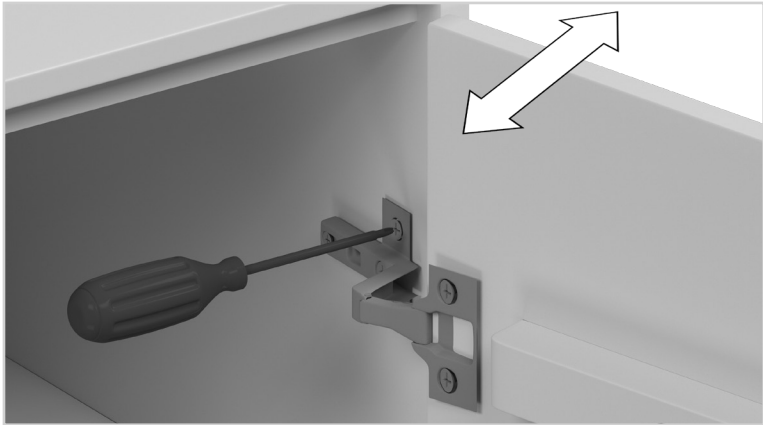

Voila! Your media unit is now assembled and secure!