

installation instructions

Compression must wait for 72 hours before it can be unfolded, and it needs to be flapped by hand

Parts list 1

A

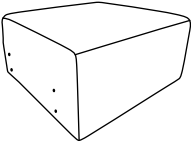

Left seat
X1

B

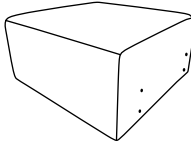

Right seat
X1

C

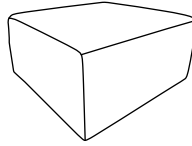

Middle seat
X2

D

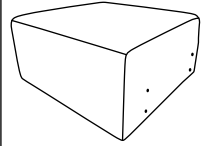

Corner seat
X1

E

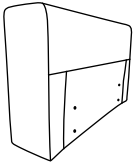

Left armrest
X1

F

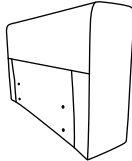

Right armrest
X1

G1



Left
Back frame
X2

G2

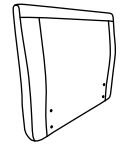

Right
Back frame
X1

G3

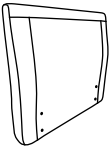

Center
back frame
X2

G4

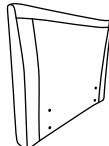

Corner
back frame
X1

H1

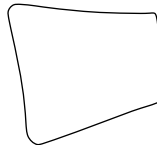

Backrest sponge
X5

H2

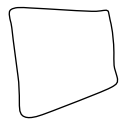

Short-backrest
sponge
X1

H3

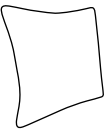

Pillow sponge
X5

I1

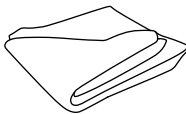

Left seat
cushion cover
X1

I2

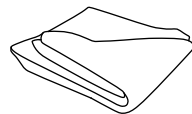

Right seat
cushion cover
X1

I3

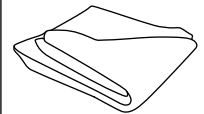

Middle seat
cushion cover
X2

Parts list 2

I4

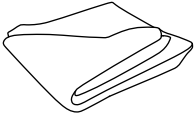

Corner seat
cushion cover
X1

J1



Backrest
pillowcase
X5

J2



Short backrest
pillowcase
X1

J3



Pillowcase
X5

K

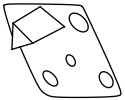

Connector
Plate-female
X4

L



Connector
Plate-male
X4

M



Gasket
X32

N1

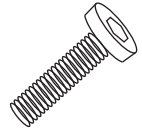

M8x50 Bolt
X32

N2

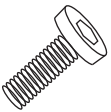

M6x15 Bolt
X16

O



Wrench
X1

P



Sofa legs
X24

Q

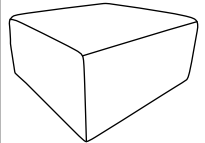

Foot pedal seat
X1

R

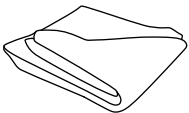

Footrest cover
X1

S

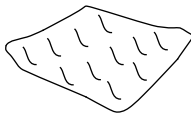

Seat cushion
sponge
X5

T

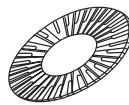

Plastic gasket
X24

U



Felt pad
X24

US882008BG0A

Ex1 Fx1 G4x1

US882008BG0B

Dx1 G1x1 H1x1 H2x1 H3x1 I4x1
J1x1 J2x1 J3x1 Kx1 Lx1 Mx8 N1x8
N2x4 Px8 Qx1 Rx1 Sx1 Tx8 Ux8

US882008BG0C

Ax1 B1x1 G1x1 G2x1 H1x2 H3x2
I1x1 I2x1 J1x2 J3x2 Kx1 Lx1 Mx16
N1x16 N2x4 Px8 Sx2 Tx8 Ux8

US882008BG0D

Cx2 G3x2 H1x2 H3x2 I3x2 J1x2
J3x2 Kx2 Lx2 Mx8 N1x8 N2x8 Px8
Sx2 Tx8 Ux8

US882008DG0A

Ex1 Fx1 G4x1

US882008DG0B

Dx1 G1x1 H1x1 H2x1 H3x1 I4x1
J1x1 J2x1 J3x1 Kx1 Lx1 Mx8 N1x8
N2x4 Px8 Qx1 Rx1 Sx1 Tx8 Ux8

US882008DG0C

Ax1 B1x1 G1x1 G2x1 H1x2 H3x2
I1x1 I2x1 J1x2 J3x2 Kx1 Lx1 Mx16
N1x16 N2x4 Px8 Sx2 Tx8 Ux8

US882008DG0D

Cx2 G3x2 H1x2 H3x2 I3x2 J1x2
J3x2 Kx2 Lx2 Mx8 N1x8 N2x8 Px8
Sx2 Tx8 Ux8

Step 1: Take out the compressed sponge bag

Open the carton, remove the compression bag inside, use a tool to cut open the compression bag (beware of sharp objects scratching the interior of the sofa), and wait for the sponge to bounce back.

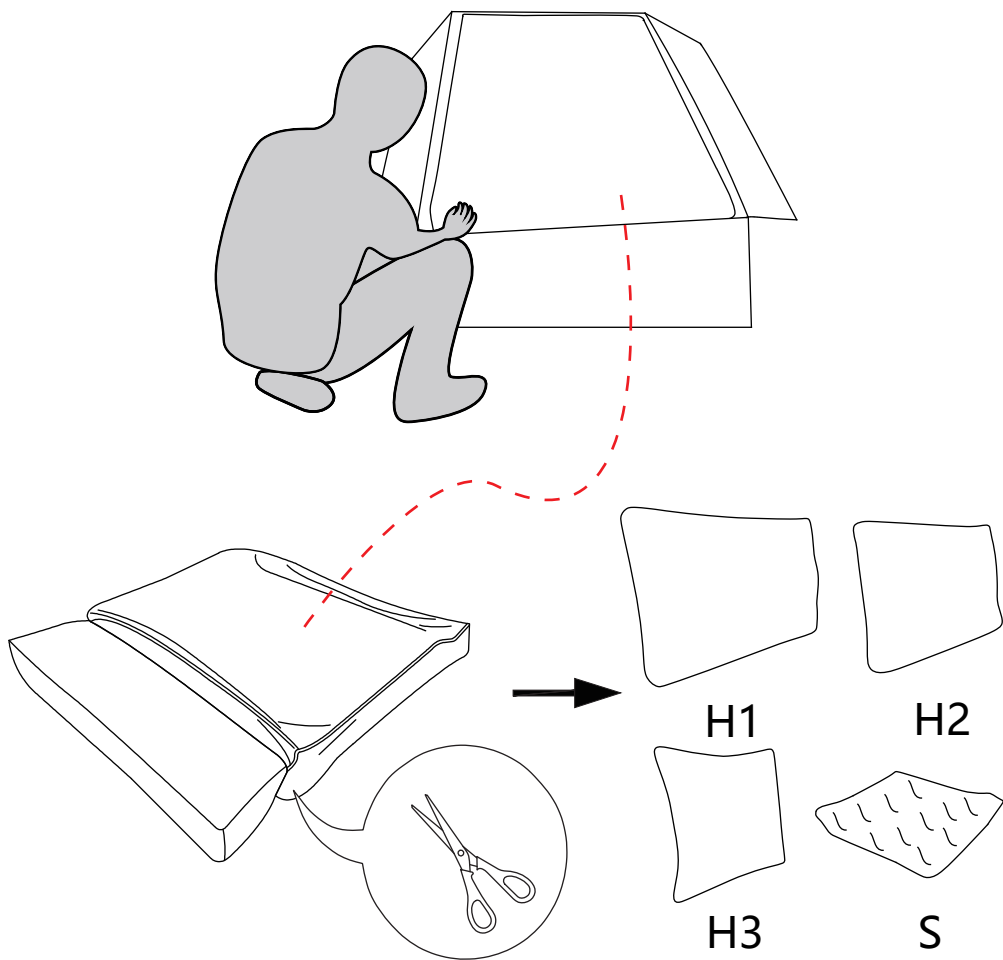

Step 2: Install the pillowcase

Put the back pillow sponge (H1&H2) over the back pillow (J1&J2), and the throw pillow (H3) over the throw pillow cover (J3).

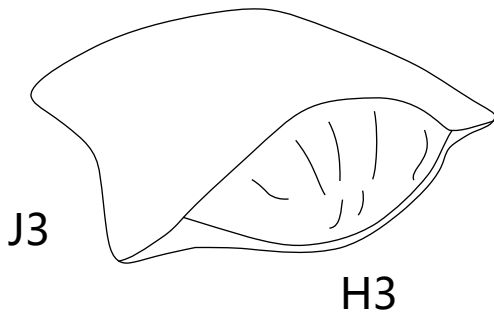
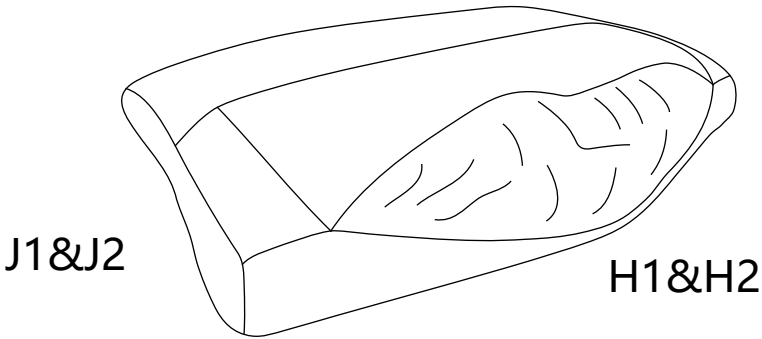

Step 3: Install the left and right seat cushion covers

Take out the left and right seat frames (A&B) and place the sponge pads (S) above them. Find the left and right seat cushion covers (I1&I2) and put them into the two seat frames. Finally, stick the adhesive cloth inside the seat cushion covers to the bottom of the seat frames. Note: The holes in the seat cushion cover should be aligned with those in the seat frame.

Don't forget to place the seat cushion sponge first and then install the seat cushion cover!

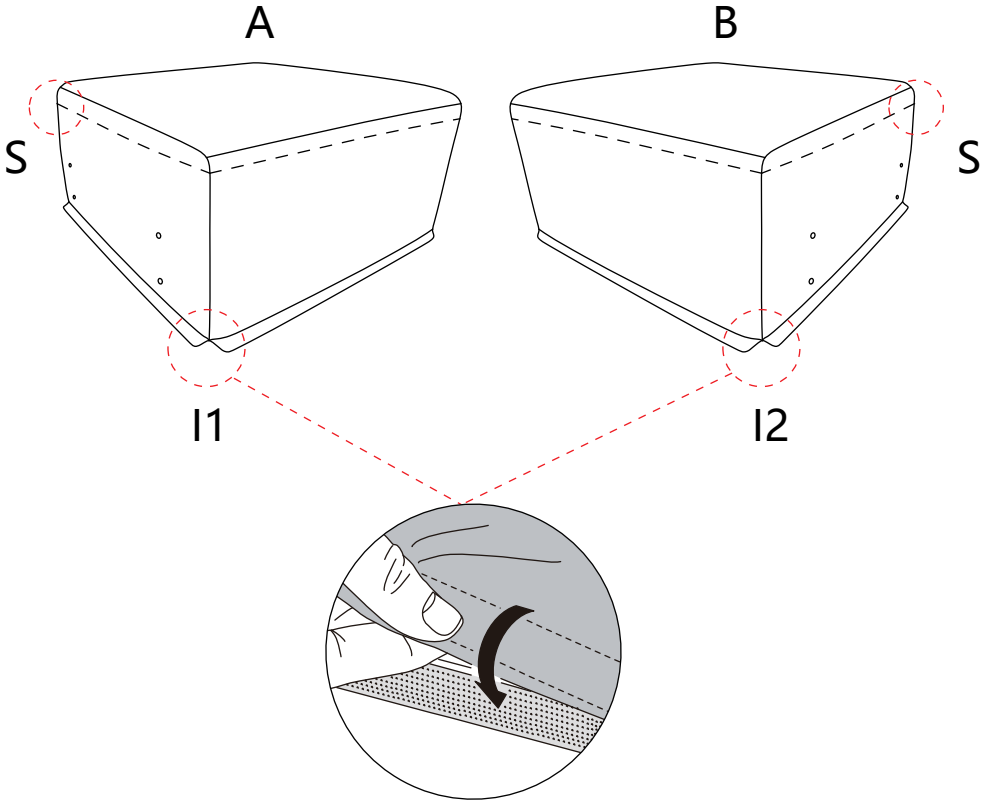

Fold the adhesive cloth inward to ensure it adheres completely to the bottom of the seat frame

Step 4: Install the footrest and corner seat cover

Take out the footrest and corner seat frame (C&D), place the sponge pad (S) above them, find the footrest and corner seat cover (I3&I4) and put them into the two seat frames. Finally, stick the adhesive cloth inside the seat cover to the bottom of the seat frame. Note: The holes in the seat cushion cover should be aligned with those in the seat frame.

Don't forget to place the seat cushion sponge first and then install the seat cushion cover!

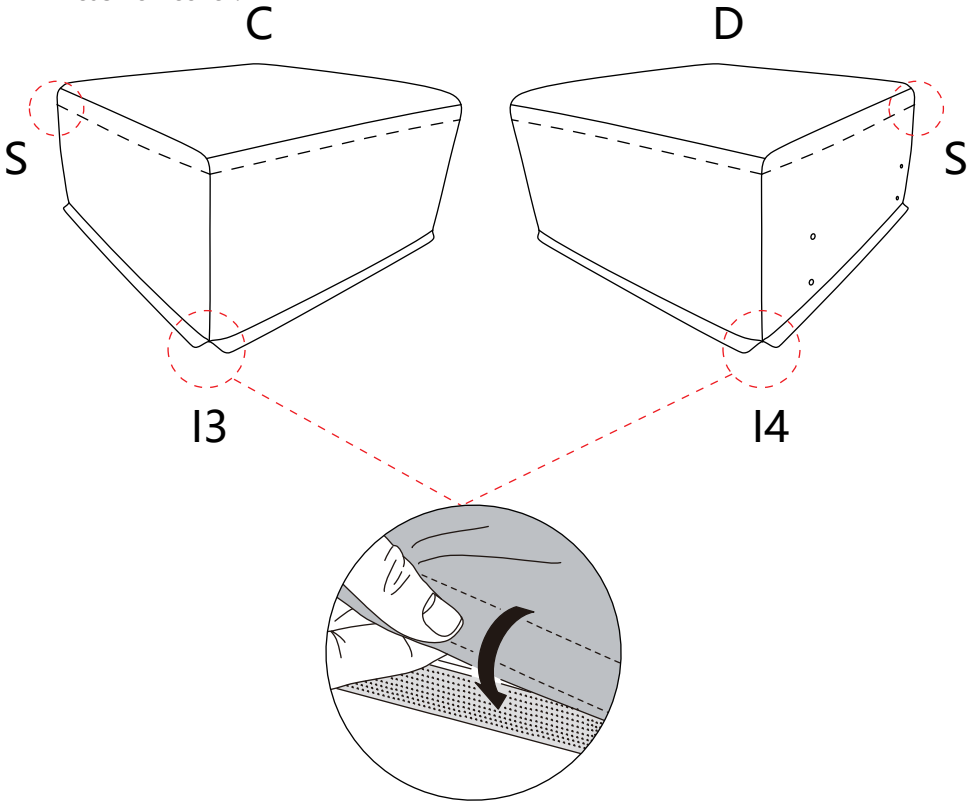

Fold the adhesive cloth inward to ensure it adheres completely to the bottom of the seat frame

Step 5: Install the backrests of the left and right seat frames

Align the holes of the left and right back frames (G1&G2) respectively with the holes at the rear of the left and right seat frames (A&B), and then tighten the M8*50mm bolts (N1) and gaskets (M) with a wrench (O) to complete the connection between the back frame and the seat frame.

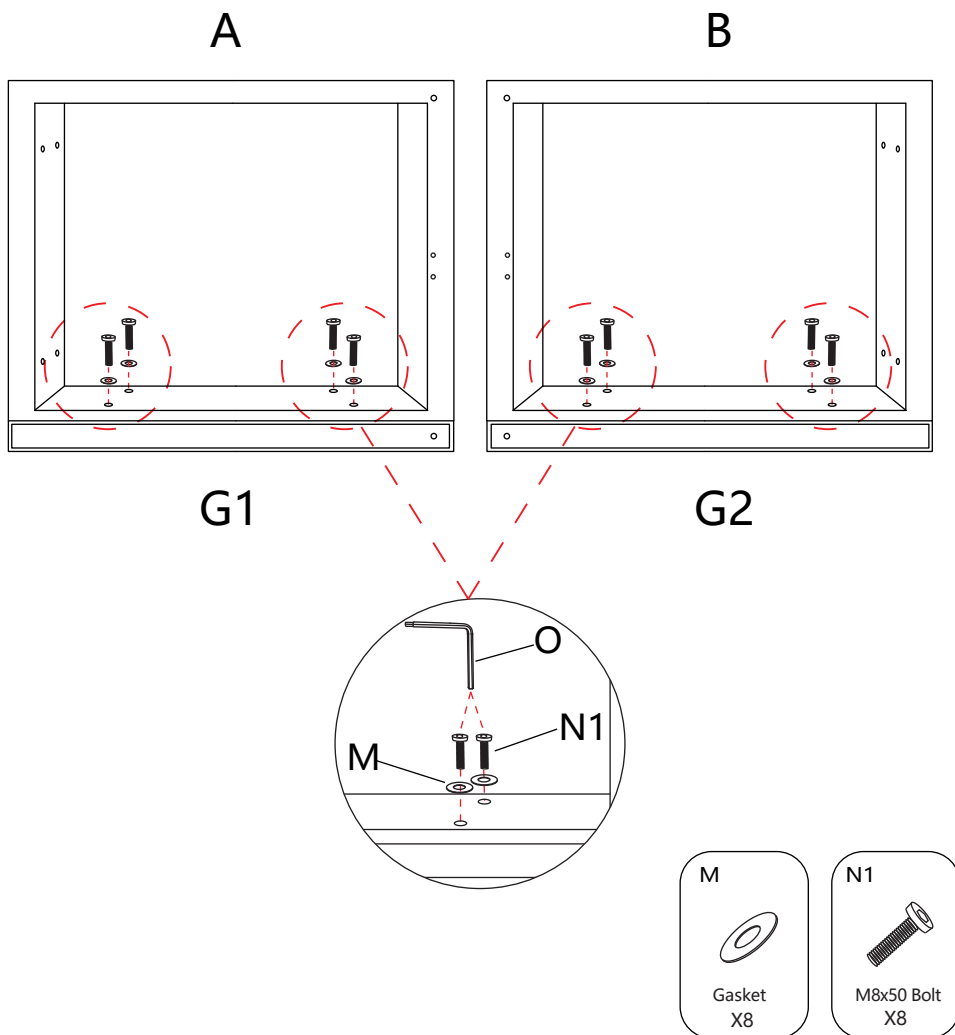

Step 6: Install the armrests of the left and right seat frames

Align the holes of the left and right handrails (E&F) with the holes on one side of the left and right seat frames (A&B) respectively. Then, use a wrench (O) to tighten the M8*50mm bolts (N1) and washers (M) to complete the connection between the handrails and the seat frames.

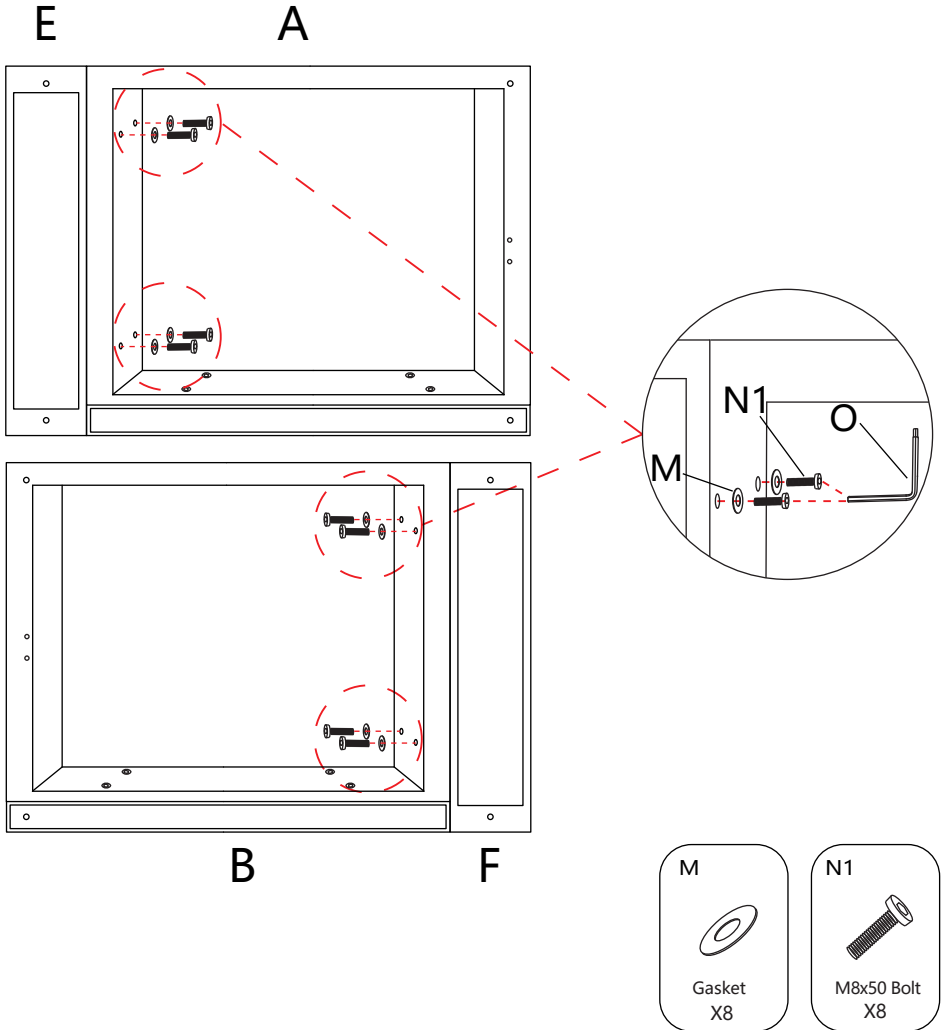

Step 7: Install the center back frame

Align the two holes of the center back frame (G3) with the two rear holes of the center seat frame (C), and complete the connection between the center seat frame and the center back frame by tightening the M8*50mm bolt (N1) and the gasket (M) with a wrench (O).

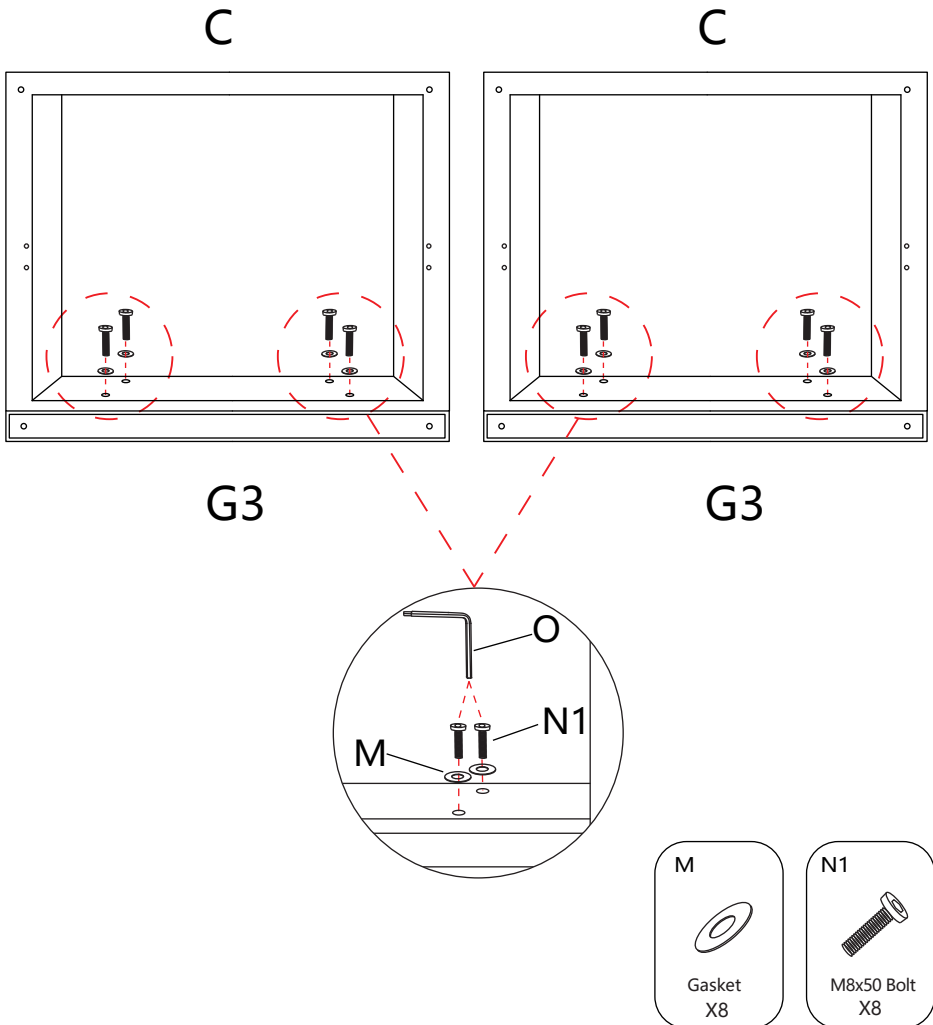

Step 8: Install the corner back frame ①

Align the holes of the corner seat frame (D) with those of the corner back frame (G4), and tighten the M8*50mm bolts (N1) with a wrench (O). Note: Don't forget to use the gasket (M).

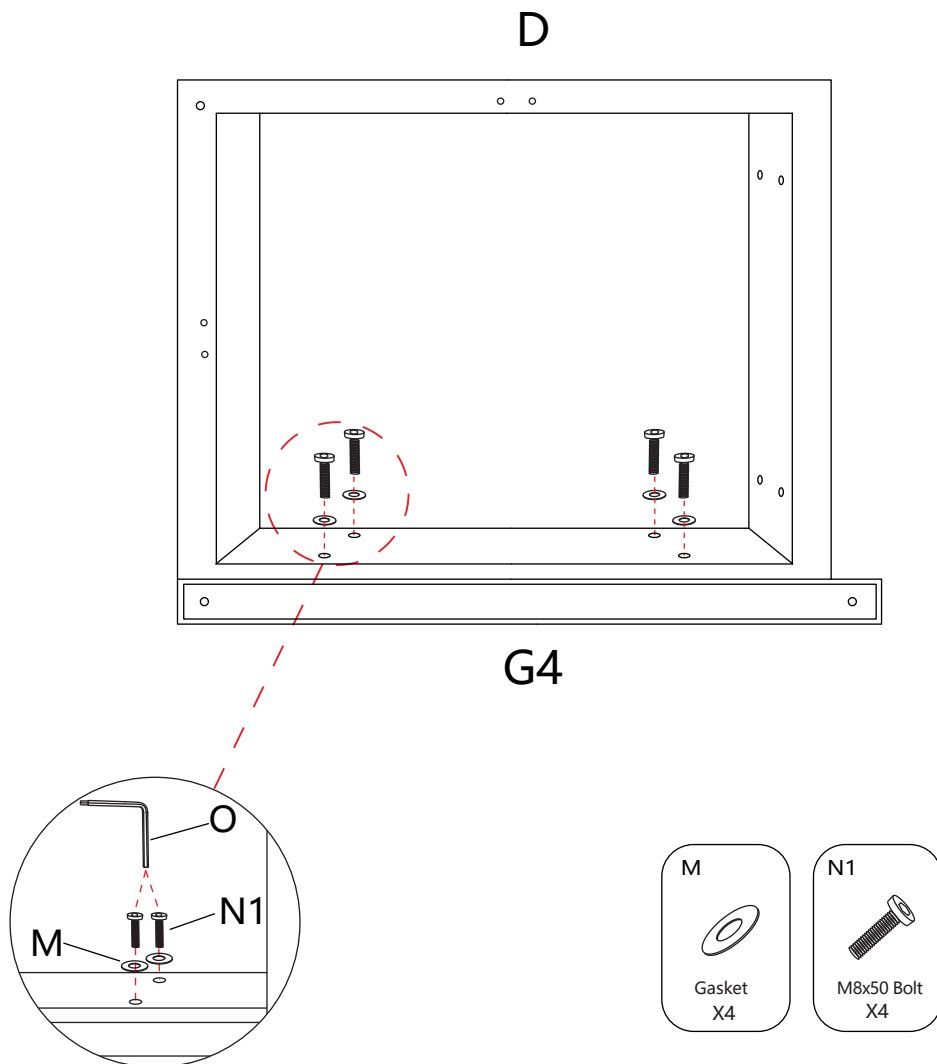

Step 9: Install the corner back frame ②

Align the hole position of the other left armrest back frame (G1) with the right hole position of the corner seat frame (D), and tighten it with a wrench (O) and M8*50mm bolts (N1) .Note: Don't forget to use the gasket (M).

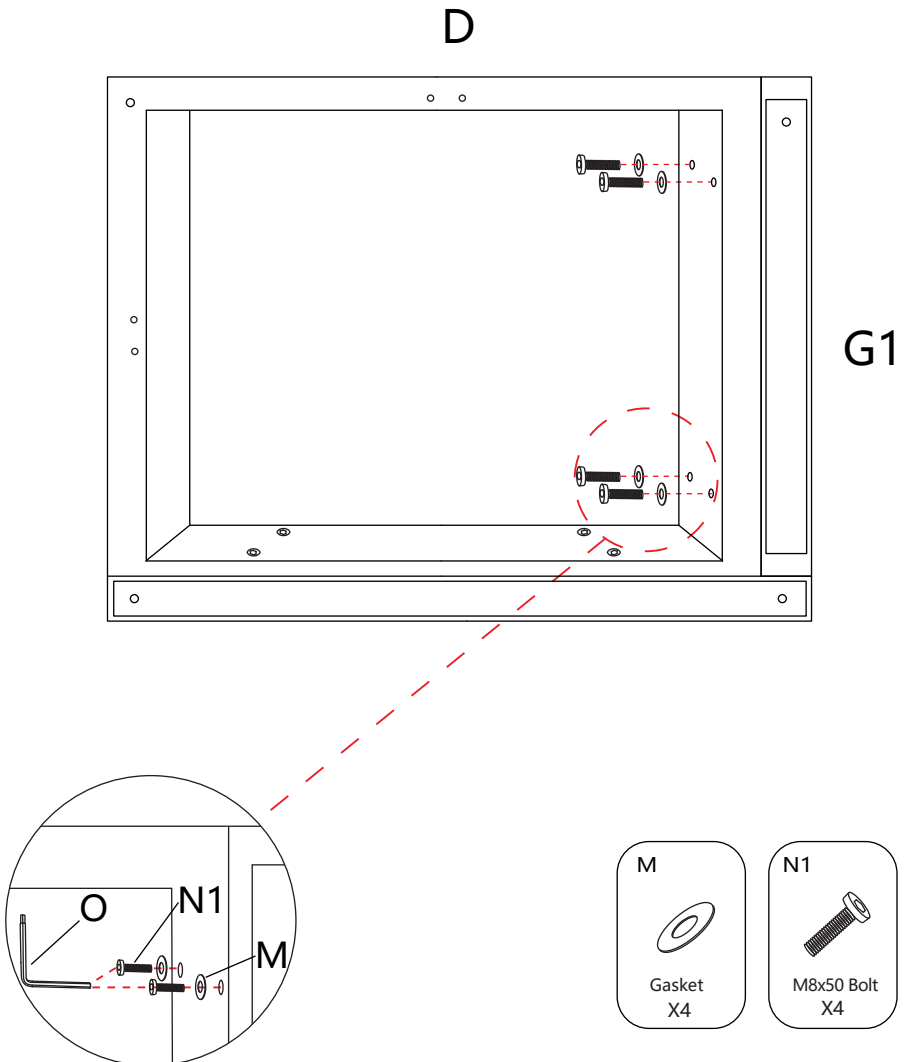

Step 10: Install the handrail seat frame plug-in

Install the Connector Plate-female (K) in the hole on the right side at the bottom of the left seat frame (A), and fasten it with a wrench (O) and 6*15mm bolts (N2) .Install the Connector Plate-male (L) in the hole on the left side of the right seat frame (B), and fasten it with a wrench (O) and M6*15mm bolts (N2) .

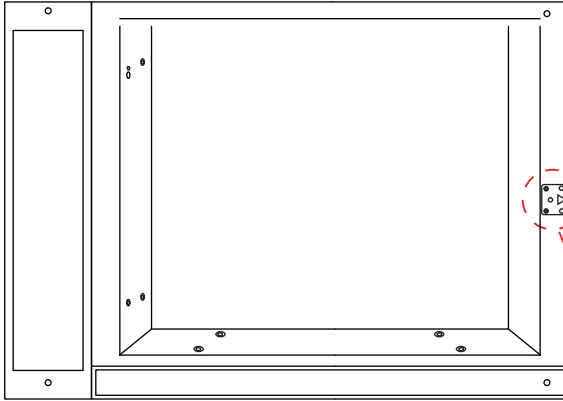

A

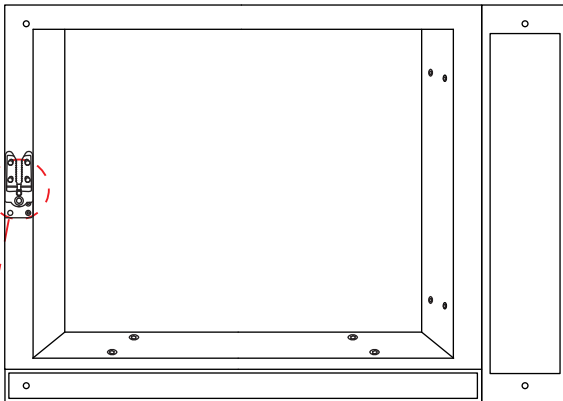

B

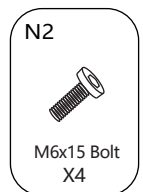
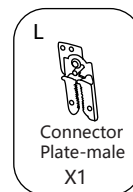
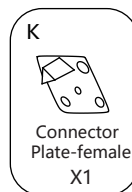
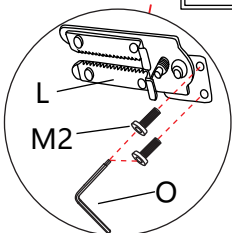

Step 11: Install the center seat frame plug-in

Install the Connector Plate-male (K) in the left hole of the middle seat frame (C), and the Connector Plate-female (L) in the right hole. Use a wrench (O) and M6*15mm bolts (N2) to tighten.

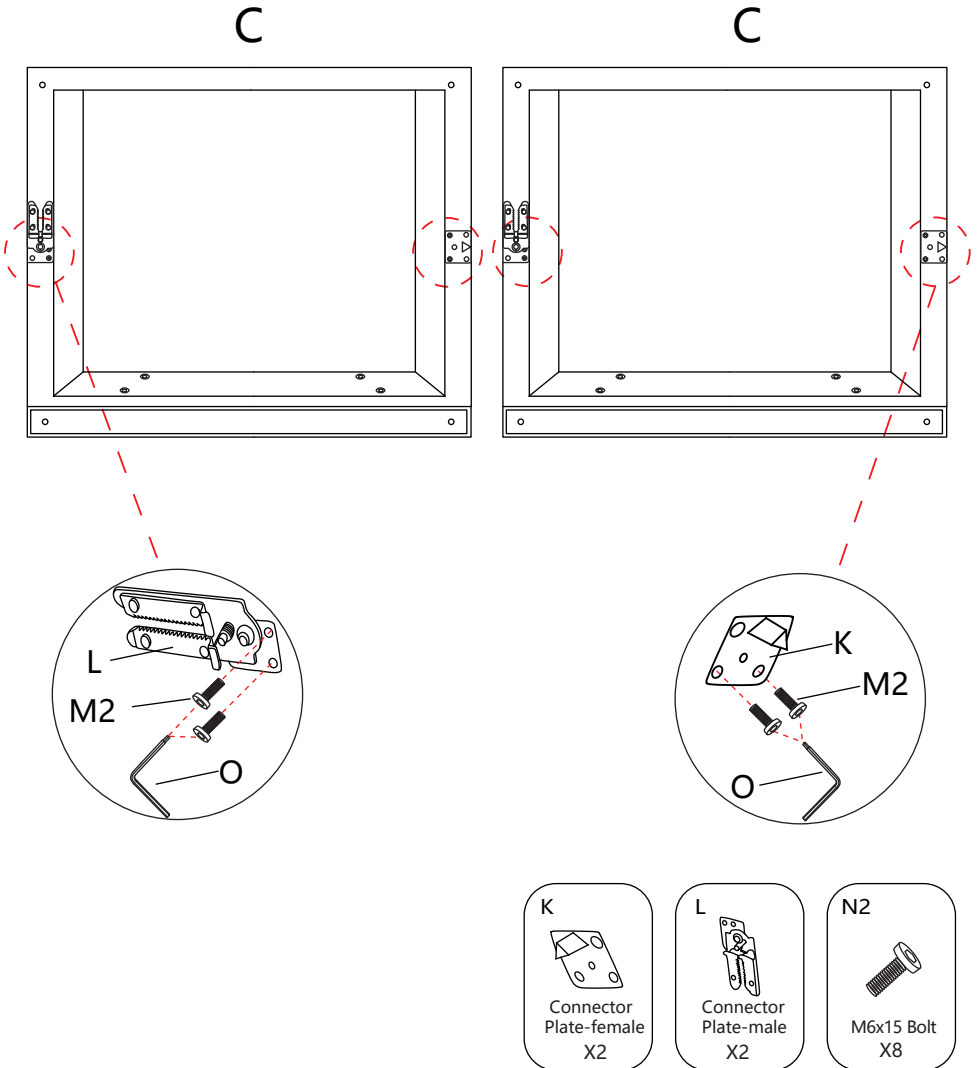

Step 12: Install the corner seat frame plug-in

Install the Connector Plate-female (L) in the left hole of the corner seat frame (D), and the Connector Plate-male (K) in the upper hole. Use a wrench (O) and M6*15mm (N2) bolts to tighten.

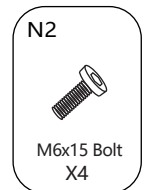
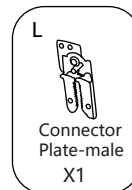
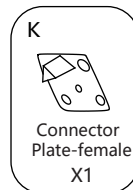
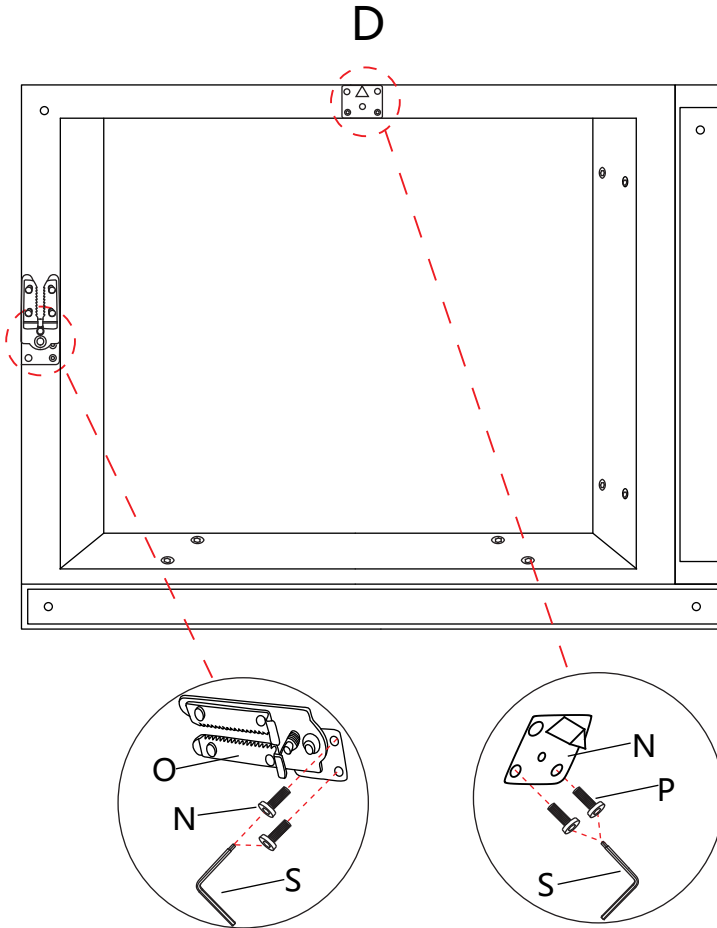

Step 13: Install the sofa legs

As shown in the following figure, first attach the felt pad (U) to the bottom of the sofa legs (P), then install the sofa legs into the holes at the bottom of the seat frame and tighten them all. Note: Do not forget to use plastic gaskets (T). All seat frame sofa legs are installed in the same way.

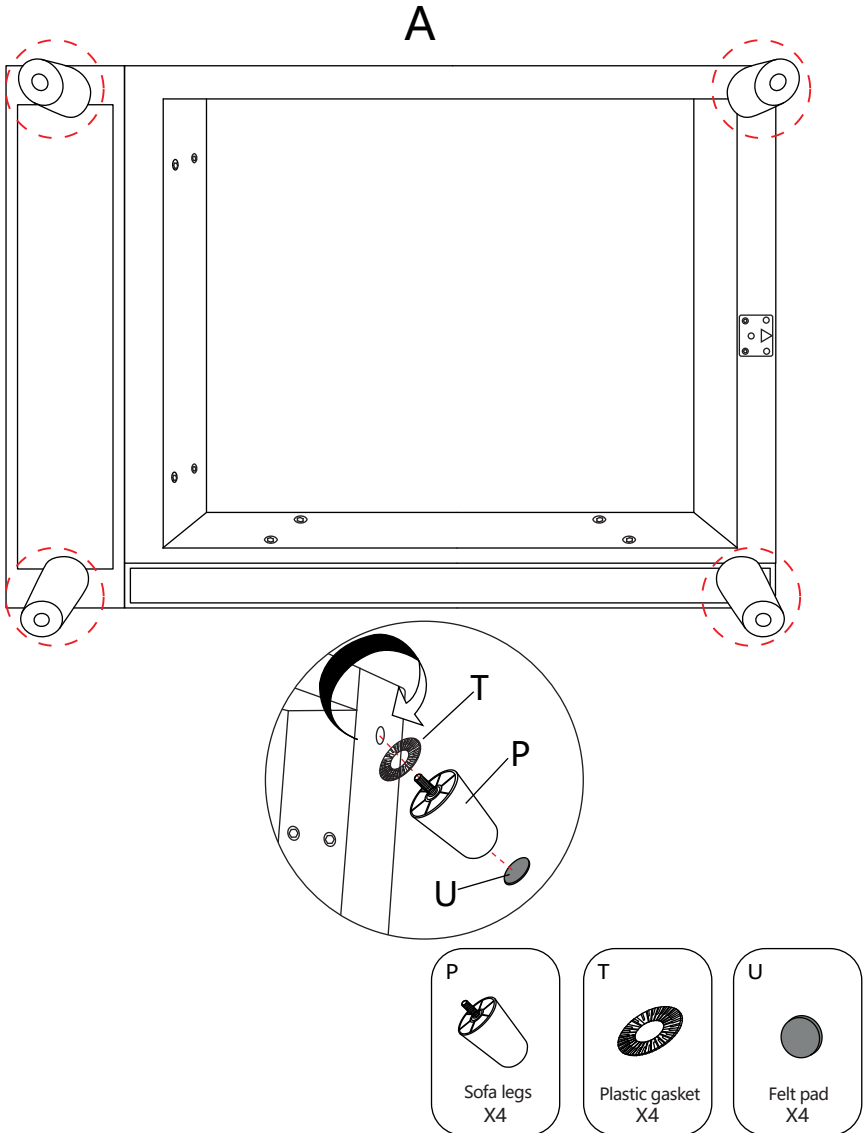

Step 14: Sofa assembly method

Just insert the Connector Plate-male into the Connector Plate-female to complete the combination of the two seat frames. Note: As shown in the following figure, hold down the two points of Connector Plate-male and push them outward to release Connector Plate-female.

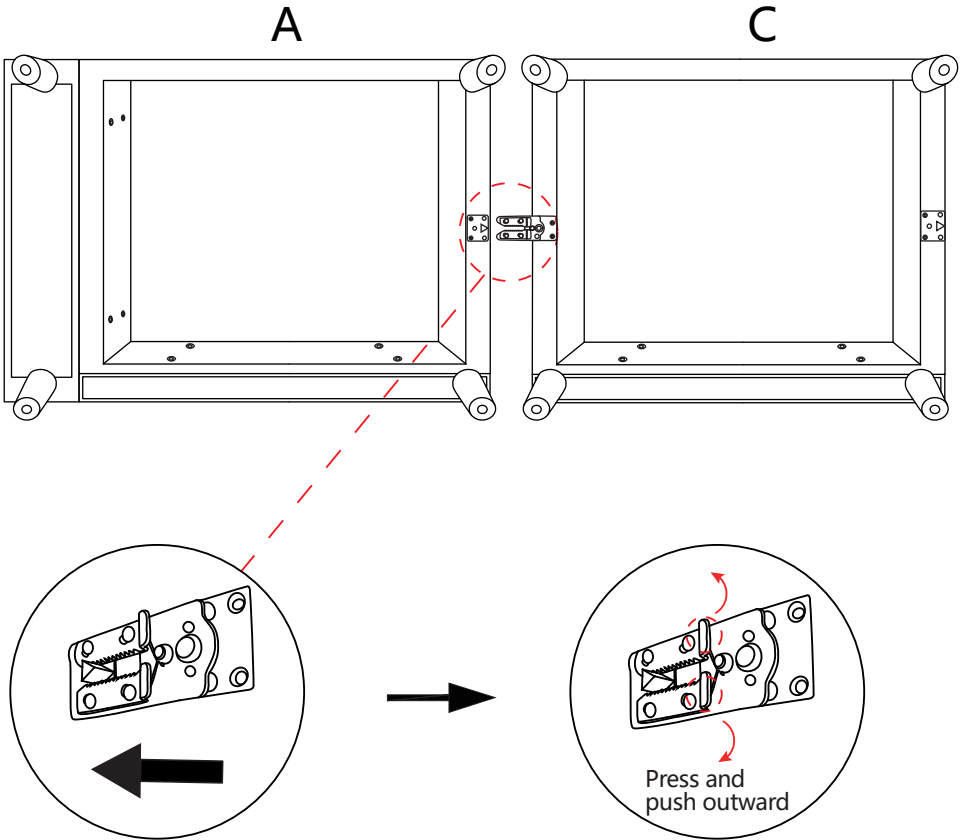

Step 15: Place the back pillow and throw pillow

Finally, just place the backrest pillows (H1&H2) and throw pillows (H3) on the sofa. This product can be freely combined and used according to the quantity of products purchased by the user.

