

SPR24UIMAN

Range size	24"
Oven energy source	Electricity
Cooktop type	Induction
Main oven	Thermo-ventilated
Cleaning system - Main oven	VaporClean
EAN code	8017709347703



Aesthetic











Front panel color	Matt black	No. of controls	2
Color	Matt Black	Display	Touch
Finishing	Satin	Handle	Robust knurled handle
Series	Professional	Handle color	Brushed stainless steel
Cooktop color	Stainless steel	Feet	Stainless steel
Control knobs	Pro-style control knobs		

Programs / Functions

No. of cooking functions 8

Traditional cooking functions

 Bake	 Convection Bake	 True European convection
 Broil	 Large grill	 Convection Broil
 Convection bottom	 Pizza	

Other functions

 Defrost by time

Cleaning functions

 VaporClean

Cooktop options



End cooking timer	4
Minute minder	1

Limited power consumption option	Yes
Multizone Option	Yes

Cooktop technical features



Cooking zones 4

Front-left - 1300 W - Booster 1400 W - Ø 18.0 cm
 Rear-left - 2300 W - Booster 3000 W - Ø 18.0 cm
 Front-right - 2300 W - Booster 3000 W - Ø 14.5 cm
 Rear-right - 1300 W - Booster 1400 W - Ø 21.0 cm

Number of Flexible zones	1
--------------------------	---

Booster power left Multizone	3700 W
------------------------------	--------

Automatic switch-off in case of over-heating	Yes
--	-----

Automatic switch-off in case of overflow	Yes
--	-----

Automatic pan detection	Yes
-------------------------	-----

Minimum pan diameter indicator	Yes
--------------------------------	-----

Selected zone indicator	Yes
-------------------------	-----

Residual heat indicator	Yes
-------------------------	-----

Main Oven Technical Features



No. of lights	1
Fan number	1
Volume	2.79 cu. ft.
Cavity material	EverClean enamel
No. of shelves	5
Light type	Halogen
Light Power	40 W
Time setting	Minute minder
Removable door	Yes
Removable inner door	Yes

Total no. of door glasses	3
Cooling system	Tangential
Bottom heating element - Power	1200 W
Upper heating element - Power	1000 W
Grill power	1700 W
Large grill - Power	2700 W
Circular heating element - Power	2000 W
Grill type	Electric
Soft Close system	Yes

Main oven options

Minimum Temperature	151 °F
---------------------	--------

Maximum temperature	500 °F
---------------------	--------

Included accessories

Oven wire rack

2

Meat Probe

1

Electrical Connection

Circuit breaker

30 A

Power cord length

47 1/4 "

Voltage

208/240 V

Frequency

60 Hz

Type of electric cable installed

Yes, Double phase

Plug

(B) NEMA 14-50P

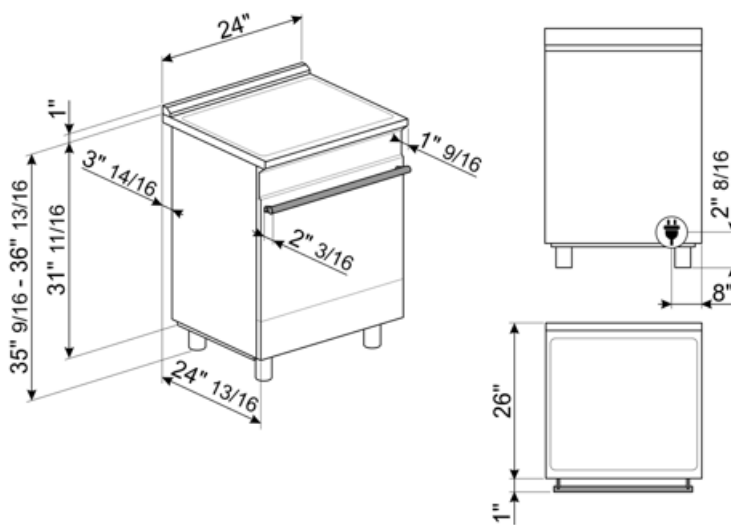

Compatible Accessories



GRILLPLATE

Universal griddle for induction, gas, ceramic and electric hobs. Non-stick surface ideal for cooking meat, cheese and vegetables. Dimensions: 410 x 240 mm.



KITTKSPR24

Plinth, 3 sides, 900mm, SPR cookers 24", black



SCRIP

Induction and ceramic hobs and teppanyaki scraper



STONE2

Rectangular pizza stone without handles, suitable for 45cm and 60cm wide ovens. Dimensions W42 x H1.8 x D37.5cm. Ideal for cooking pizzas with the same results as a typical wood-fired oven. Can also be used for baking bread, focaccias and other recipes such as pies, flans or biscuits



GTP

Partial-extension telescopic guides Length: 14" Extraction: 11 1/4" Material: Stainless steel AISI 430 polished



PALPZ

Pizza shovel with fold away handle width: 315mm length : 325mm



SFLK1

Child lock

Alternative products



SPR24UIMMW

Color: Matte white



SPR24UIMANX



















Color: Matt Black















SPR24UIMX

Color: Stainless steel

Symbols glossary

 <p>Automatic merge of zones for a bigger area</p>	 <p>Compact Slider back-lighted ghost effect</p>
 <p>Air cooling system: to ensure a safe surface temperatures.</p>	 <p>Defrost by time: with this function the time of thawing of foods are determined automatically.</p>
 <p>B: Product energy rating, measured from A+++ to D / G depending on the product family.</p>	 <p>Triple glazed doors: Number of glazed doors.</p>
 <p>ECO-logic: option allows you to restrict the power limit of the appliance real energy saving.</p>	 <p>Enamel interior: The enamel interior of all Smeg ovens have a special antacid lining which helps keep the interior clean by reducing the amount of cooking grease adhering to it.</p>
 <p>Circogas: In gas ovens the fan distributes the heat quickly and evenly throughout the oven cavity, avoiding flavour transfer when cooking a number of different dishes at the same time. In electric ovens this combination completes cooking more quickly of foods that are ready on the surface, but that require more cooking inside, without further browning.</p>	 <p>Fan with upper and lower elements: The elements combined with the fan aim to provide more uniform heat, a similar method to conventional cooking, so pre-heat is required. Most suitable for items requiring slow cooking methods.</p>
 <p>Upper and lower element only: a traditional cooking method best suited for single items located in the centre of the oven. the top pf the oven will always be hottest. Ideal for roast, fruit cakes, bread etc.</p>	 <p>True European Convection: The combination of the fan and circular heating element around it provides many benefits, including no preheat if cooking time is longer than 20 minutes, no flavor transfer when cooking different foods at the same time, lower energy consumption, and shorter cooking times. Suitable for all types of food preparations.</p>
 <p>Grill element: Using of grill gives excellent results when cooking meat of medium and small portions, especially when combined with a rotisserie (where possible). Also ideal for cooking sausages and bacon.</p>	 <p>Half grill: For rapid cooking and browning of foods. Best results can be obtained by using the top shelf for small items, the lower shelves for larger ones, such as chops or sausages. For half grill heat is generated only at the centre of the element, so is ideal for smaller quantities.</p>
 <p>Fan with grill element: The fan reduces the fierce heat from the grill, providing an excellent method of grilling various foods, chops, steaks, sausages etc. giving even browning and heat distribution, without drying out the food. The top two levels recommended for use, and the lower part of the oven can be used to keep items warm at the same time, an excellent facility when cooking a grilled breakfast. Half grill (centre portion only) is ideal for small quantities of food.</p>	 <p>Pizza function: The simultaneous operation of three elements ensures an optimum cooking facility when used with the Smeg pizza stone.</p>
 <p>Overheat protection: The safety system that automatically turns off the hob in case of overheating of the control unit.</p>	 <p>Induction: The work of these hobs is based on the principle of electromagnetic induction. The heat is generated directly in the bottom of the pan during its contact with the hob.</p>

-
- | | |
|--|---|
|  All glass inner door: All glass inner door, a single flat surface which is simple to keep clean. |  The inner door glass: can be removed with a few quick movements for cleaning. |
|  Side lights: Two opposing side lights increase visibility inside the oven. |  Automatic opening: some models have Automatic opening door when the cycle is finished which is a perfect solution for handle-less kitchen units as no handle is needed. For safety reasons, the door locks automatically when the machine is in use to avoid it being opened inadvertently. |
|  Overfill protection: The special overfill protection shuts down the stove in the presence of overflow of liquids. |  Indication of residual heat: After the glass ceramic hob is switched off the residual heat indicator shows which of the heating zones still remains hot. When the temperature drops below 60 ° C, the indicator goes out. |
|  The oven cavity has 5 different cooking levels. |  Soft close: all models are equipped with advanced function of smooth closing of the door, which allows the device to close smoothly and quietly. |
|  Timer: All ceramic hobs have a timer which automatically ends cooking after a preset time. |  Vapor Clean: a simple cleaning function using steam to loosen deposits in the oven cavity. |
|  The capacity indicates the amount of usable space in the oven cavity in litres. |  ... |