

10 x 13 FT

□ □ □ □ □ □ □ □ HWG - 013 □ □ □ □ □ □ □ □

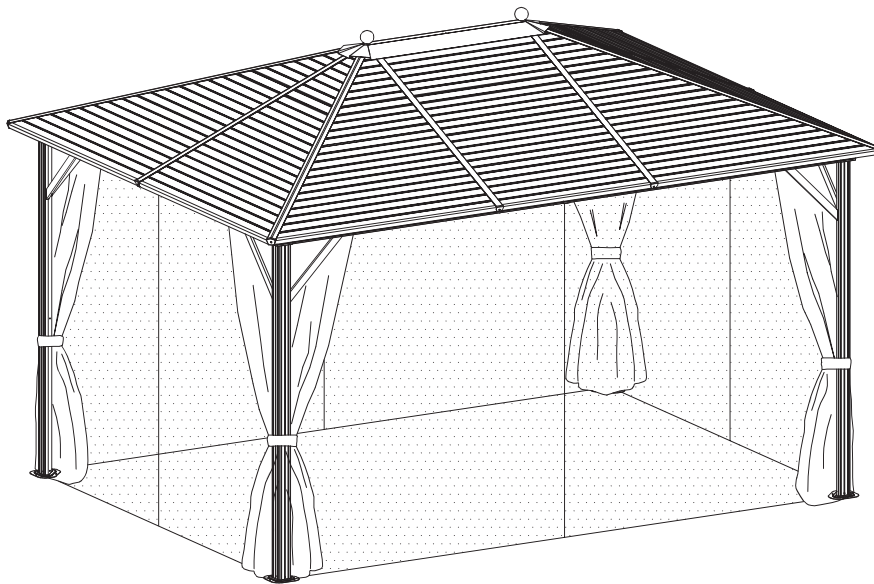

At least need 3person work together

REQUIRED TOOLS

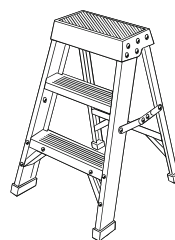
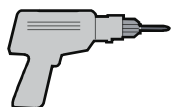

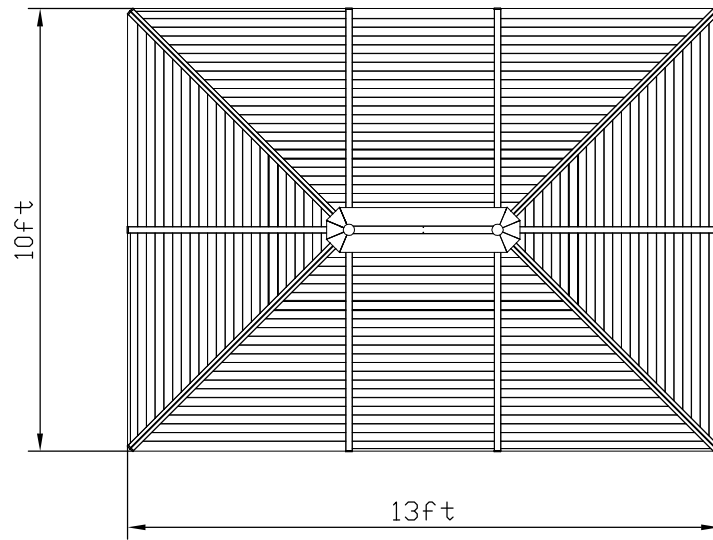
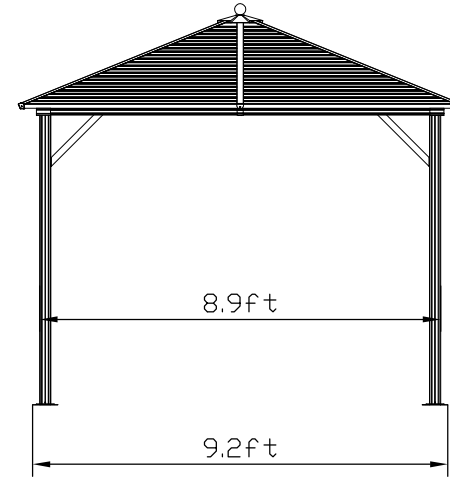
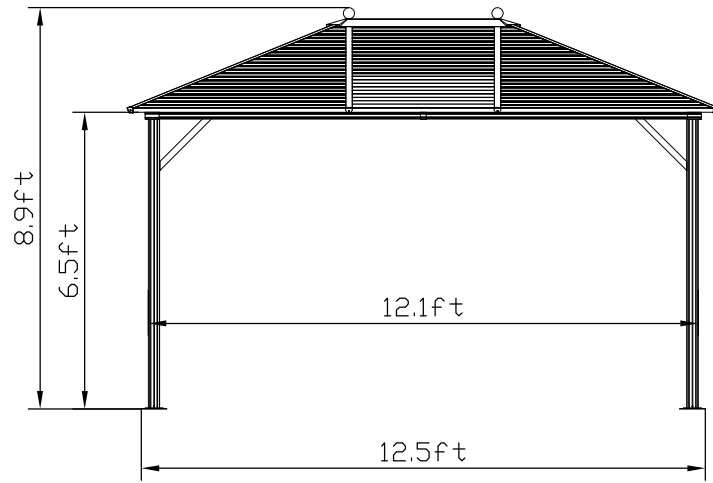



(A) 4x



(B) 2x



(B1) 2x



(C) 2x



(C1) 2x

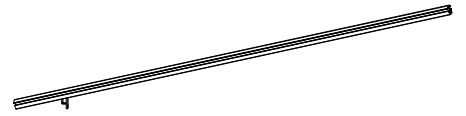

(D) 4x



(E) 6x



(F) 2x



(F1) 4x

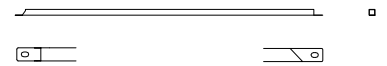

(F2) 4x



(G) 2x



(G1) 4x



(G2) 4x



(H1) 4x

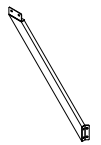

(H2) 4x

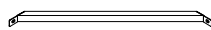

(H) 4x

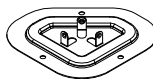











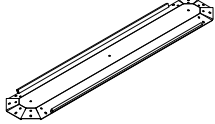
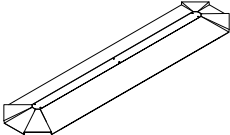

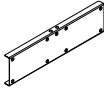
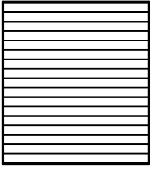
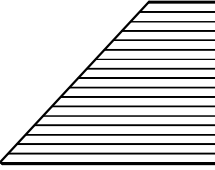
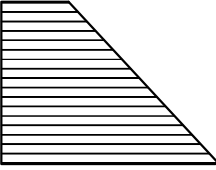
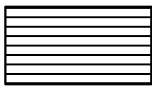

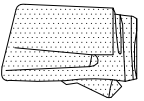
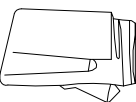

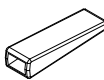

(J) 4x



(K) 4x

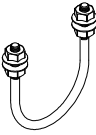

(K1) 4x

 L 1x	 M 1x	 N 4x	 N1 6x
 P 4x	 Q 2x	 Q1 4x	 Q2 4x
 R 2x	 R1 4x	 R2 4x	 S 4x
 T 4x	 U 112x	 V 4x	 Y 20x
 Y1 12x	 Z 2x	 S4 1x	
 M6x15 1 103x	 M6x10 2 32x	 M5x12 3 48x	 ST4.8x12 4 24x
 5 2x	 ST4x8 7 12x	 8 12x	 10 1x

<1>

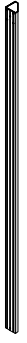

A 4x

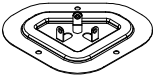

J 4x



3 12x M5x12

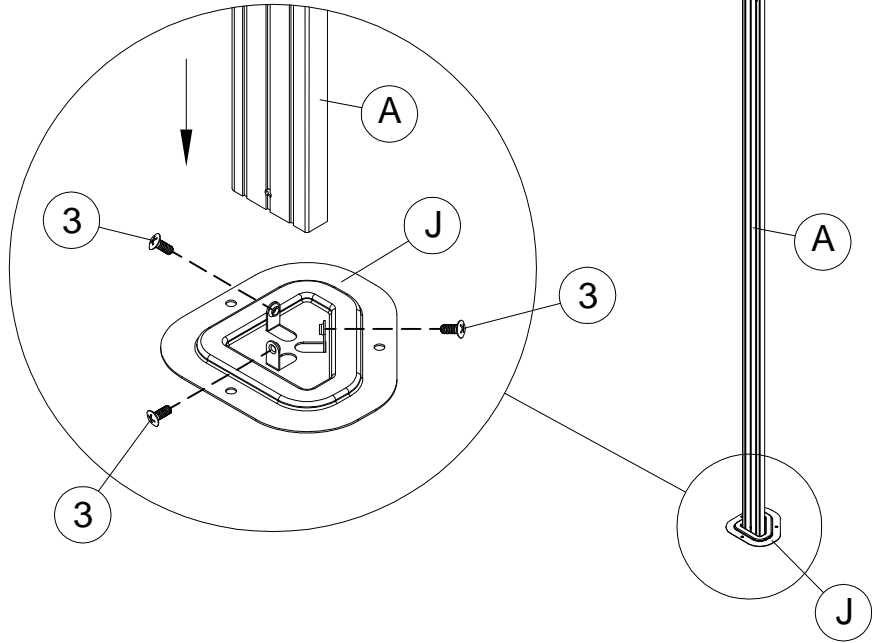

4

<2>

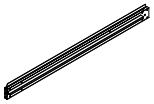

B 2x

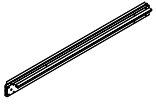

B1 2x

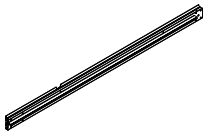

C 2x

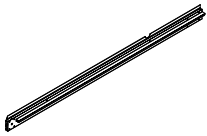

C1 2x

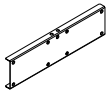

P 4x



1 42x M6x15

5

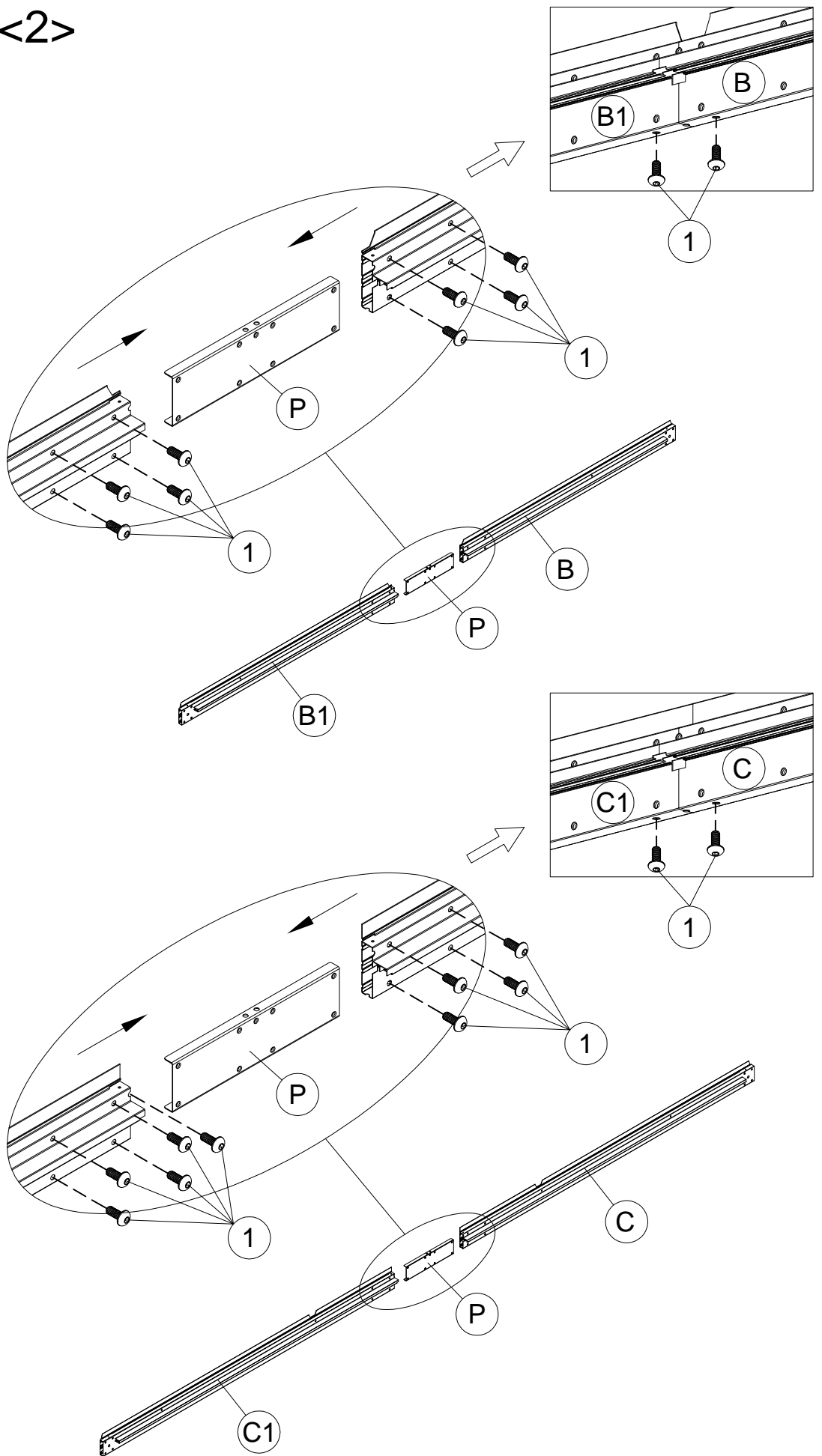



2 M6x10
32x

<3>

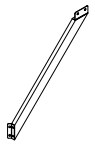
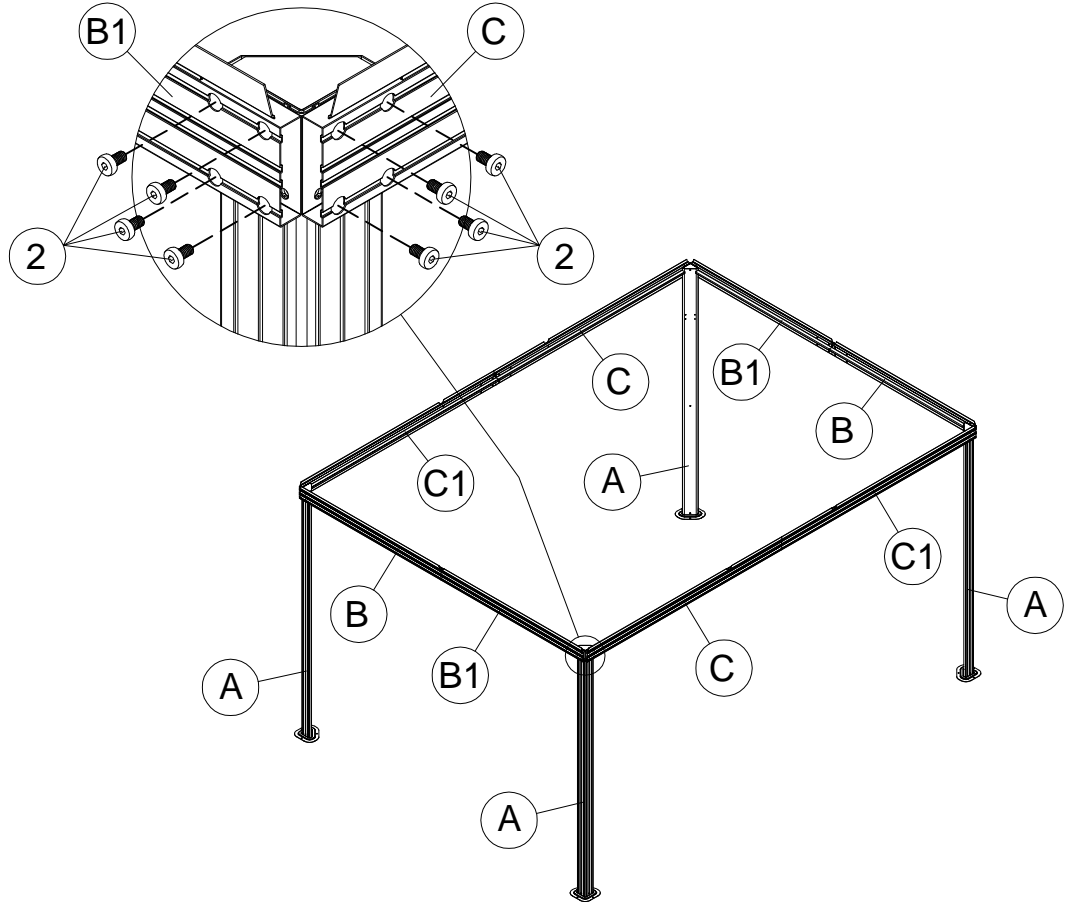

H1 4x

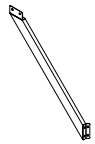

H2 4x



3 M5x12
32x

<4>

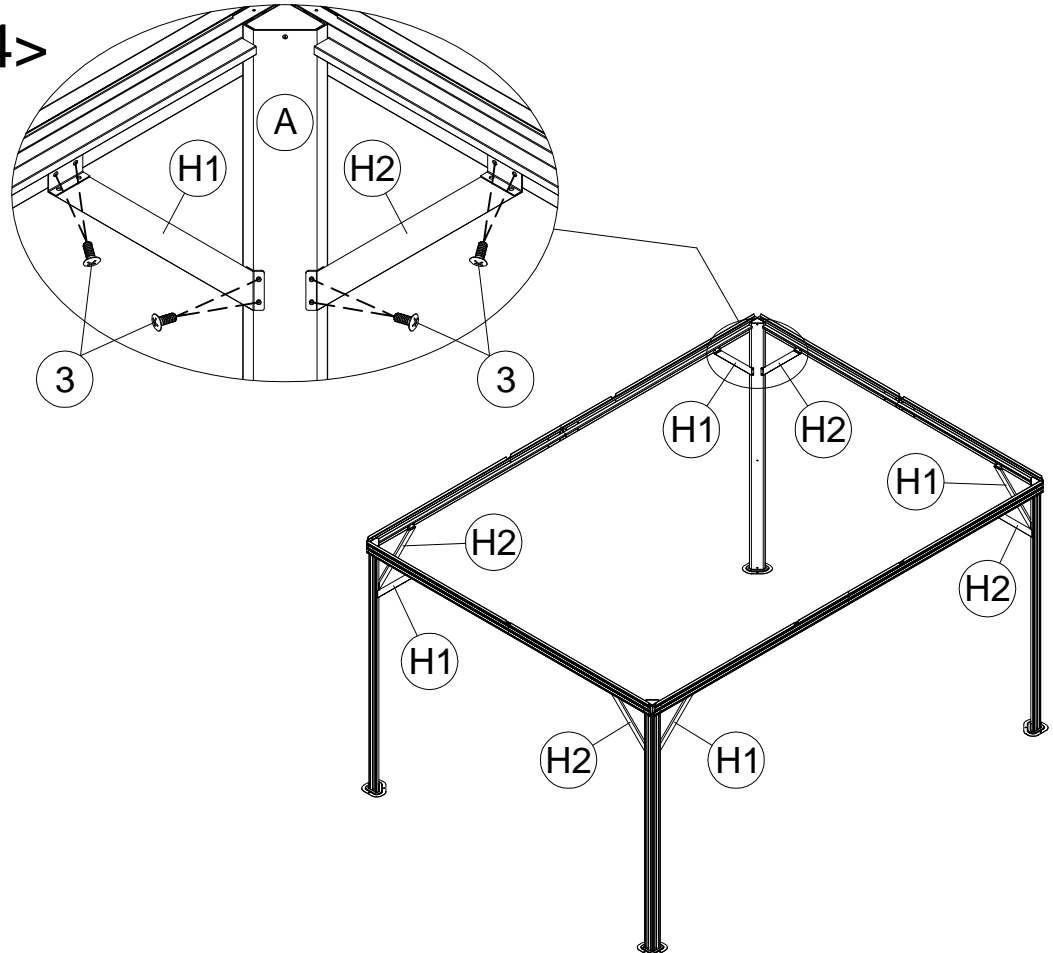

6



<5>

H 4x



1 8x M6x15

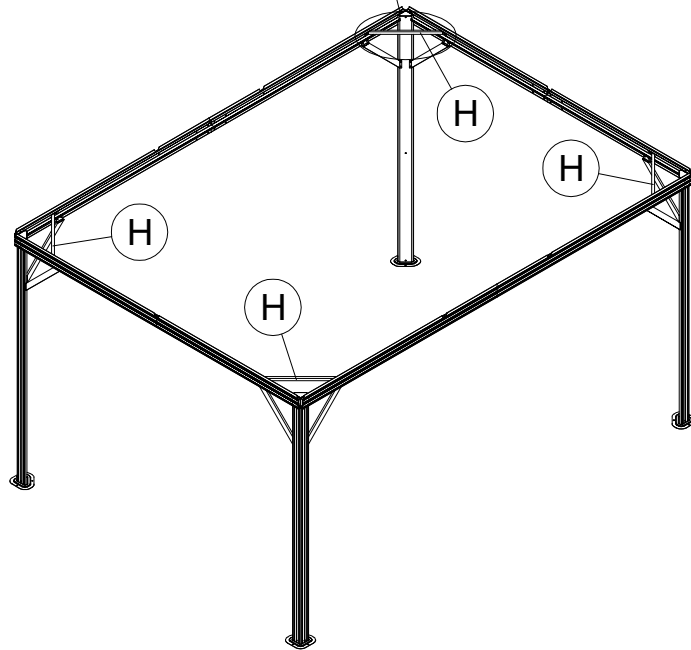
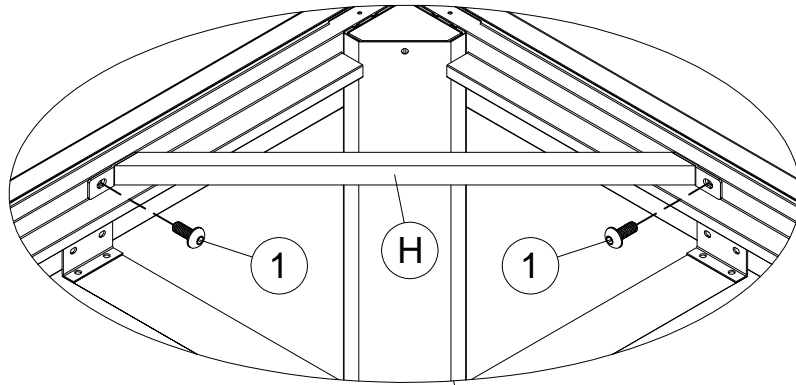

7



(K) 4x



(K1) 4x



(U) 112x



(V) 4x



(3) 4x M5x12



(4) 24x ST4.8x12

<6>

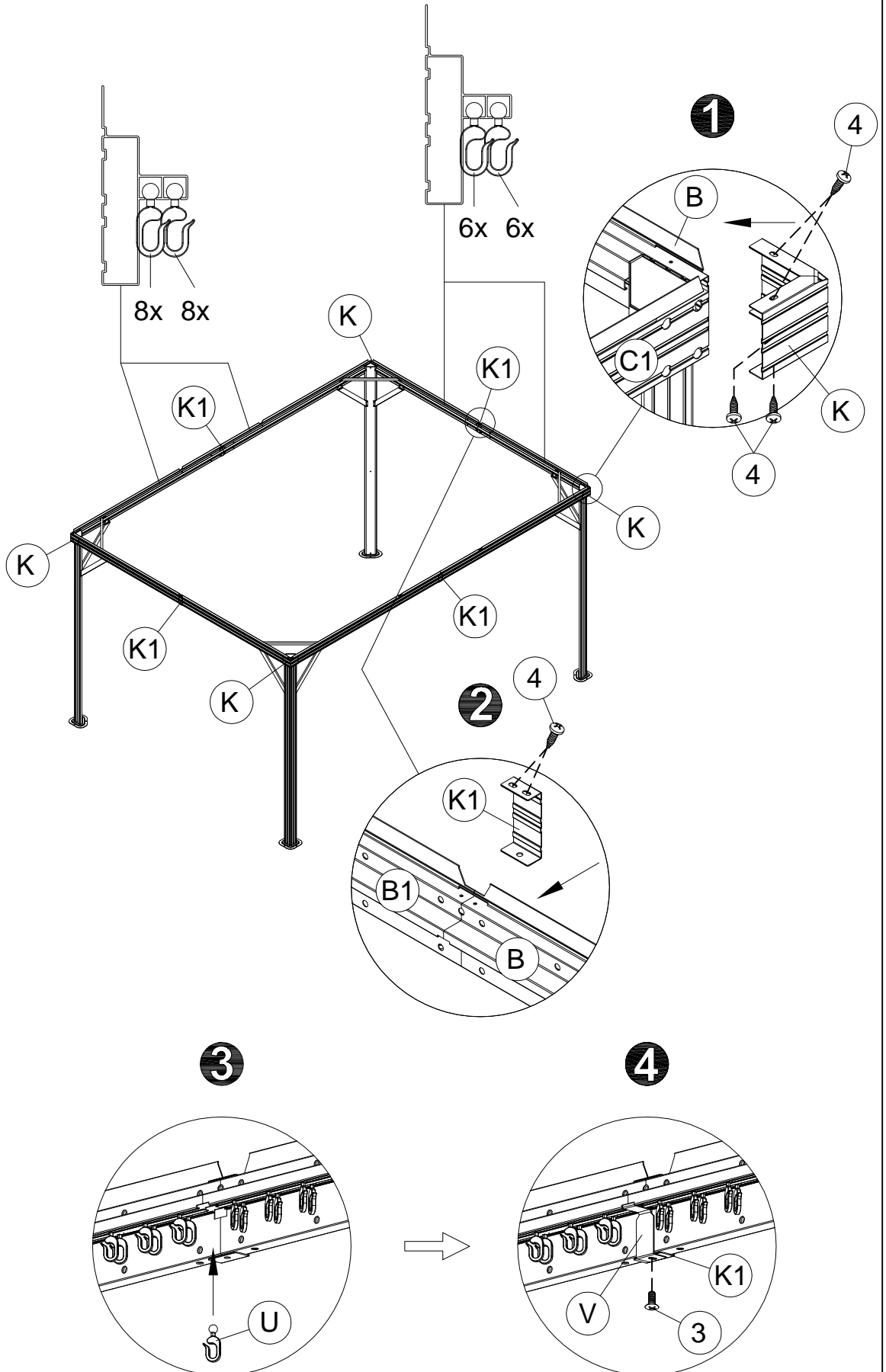

8



<7>

D 4x

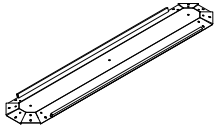

L 1x



1 8x M6x15

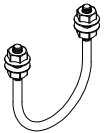

10 1x

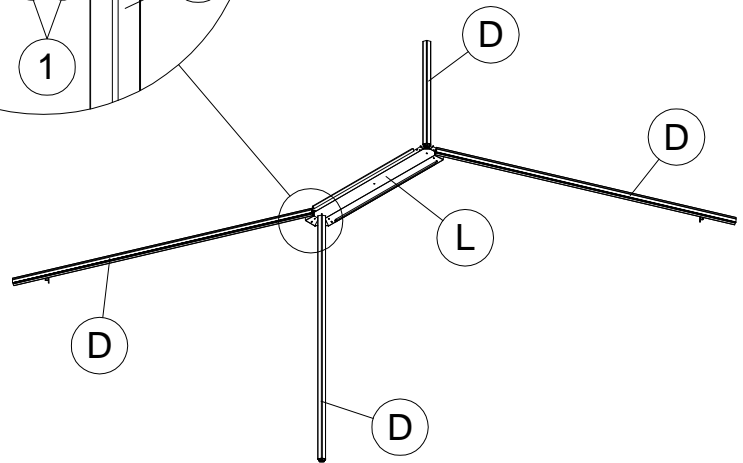
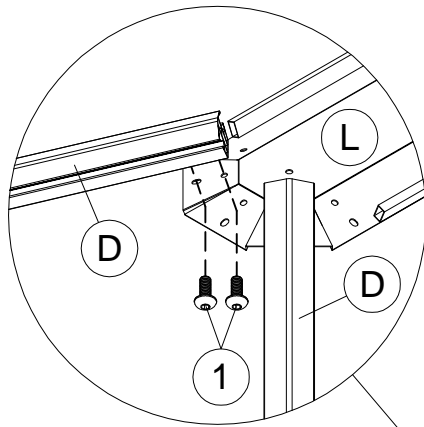
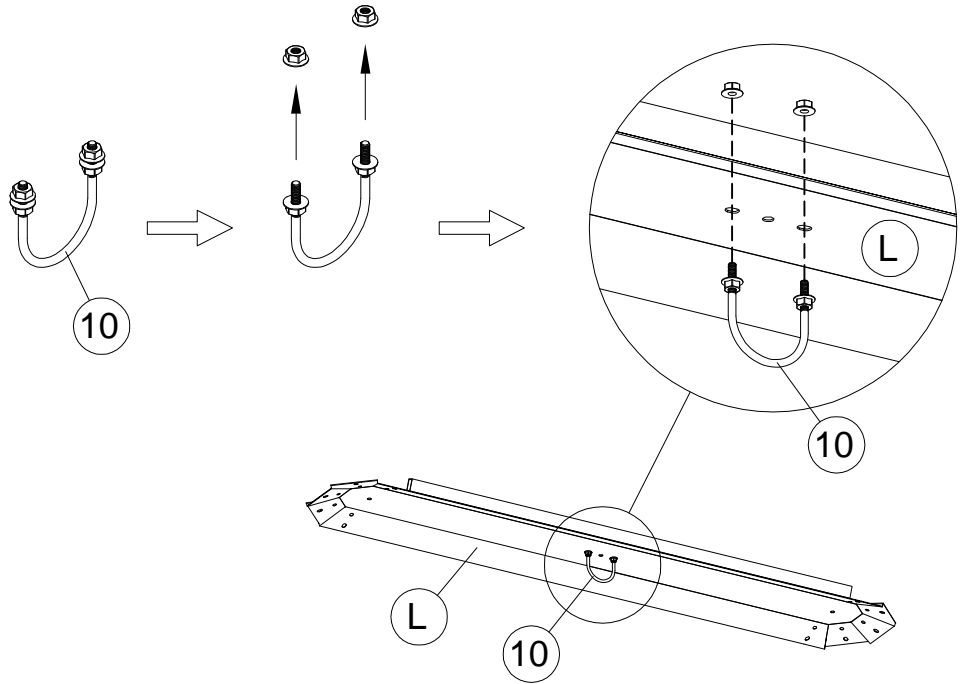

9



<8>

1

4x

M6x15

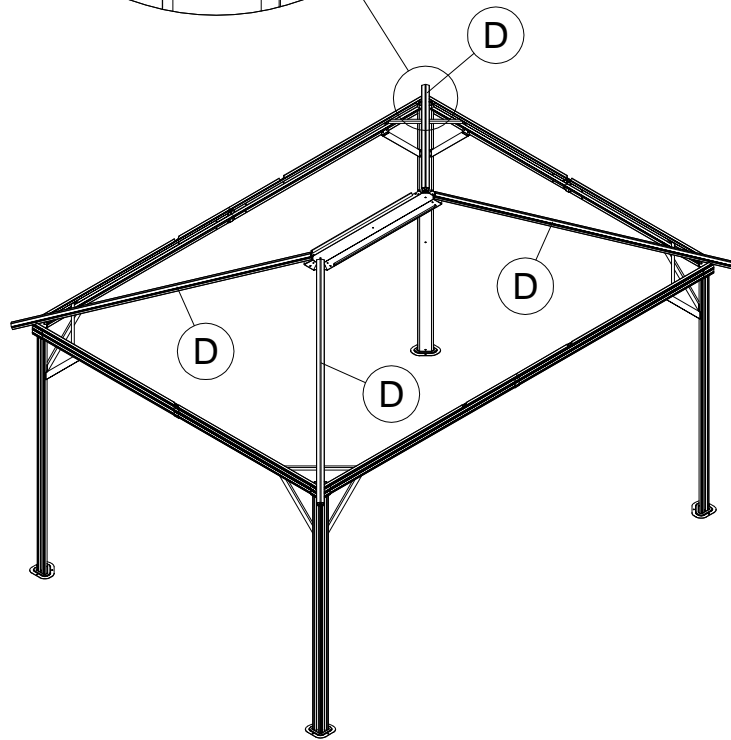
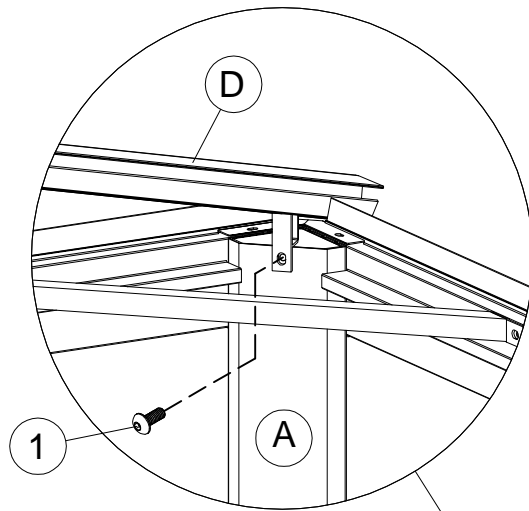

10



<9>

E 6x



M6x15
1 18x

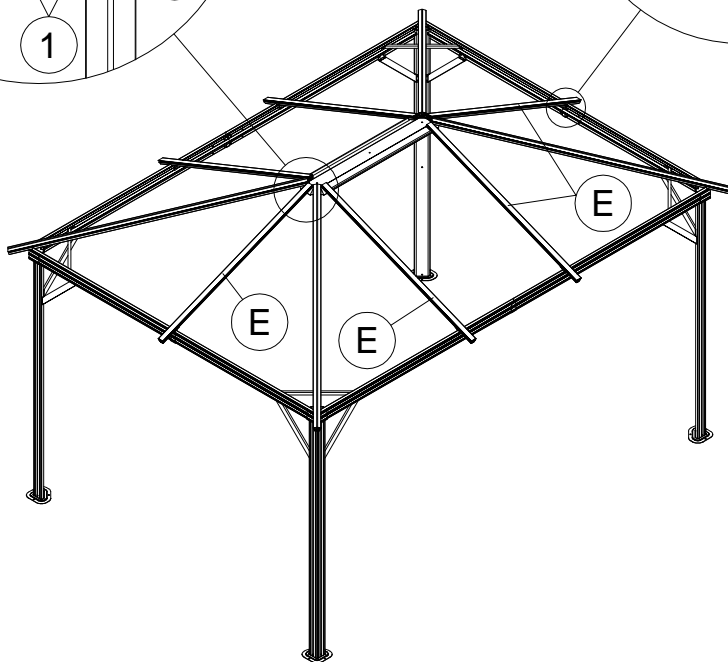
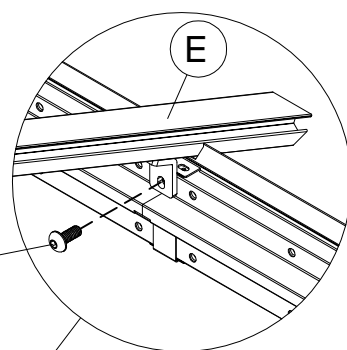
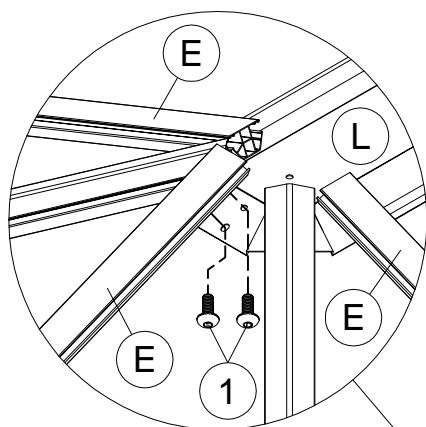

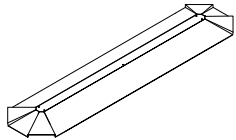

(M) 1x



(Z) 2x



(1) 3x M6x15



(5) 2x

<10>

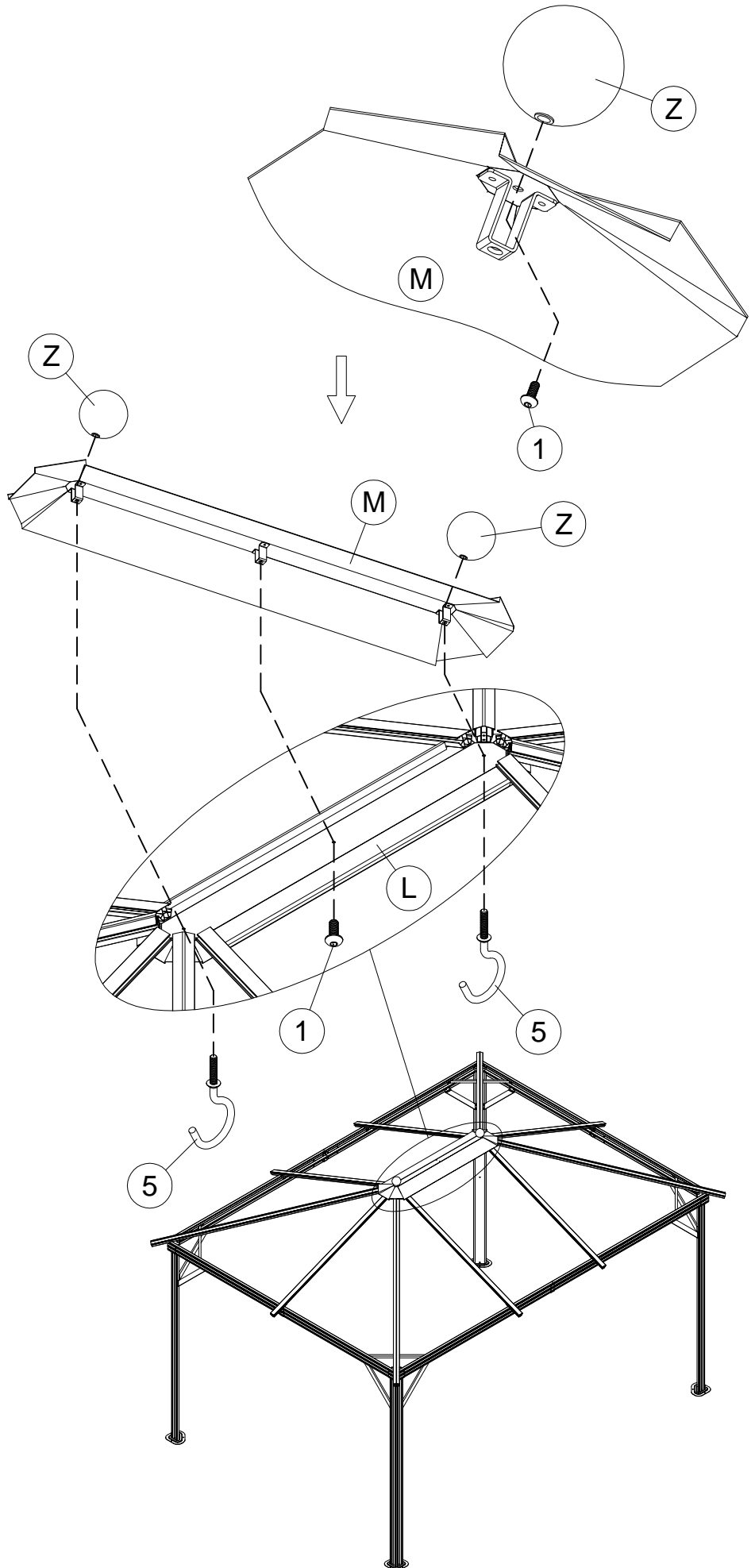

<11>

F 2x

F1 4x

F2 4x

1 10x M6x15

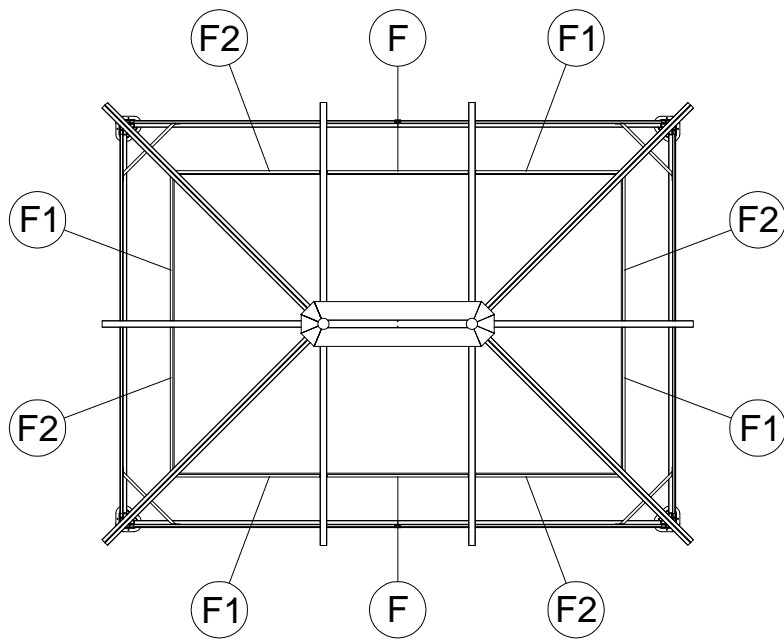
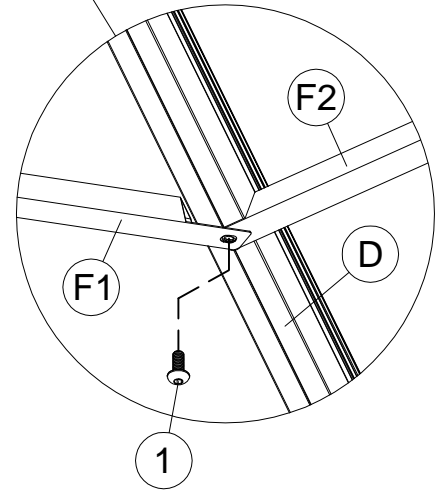
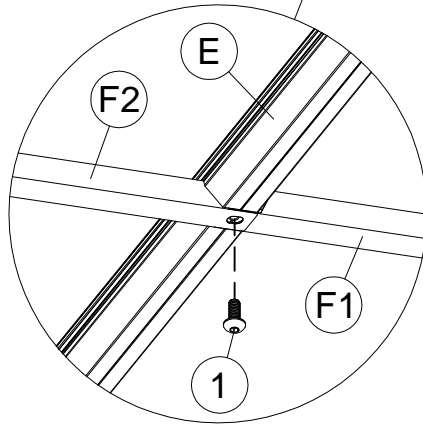
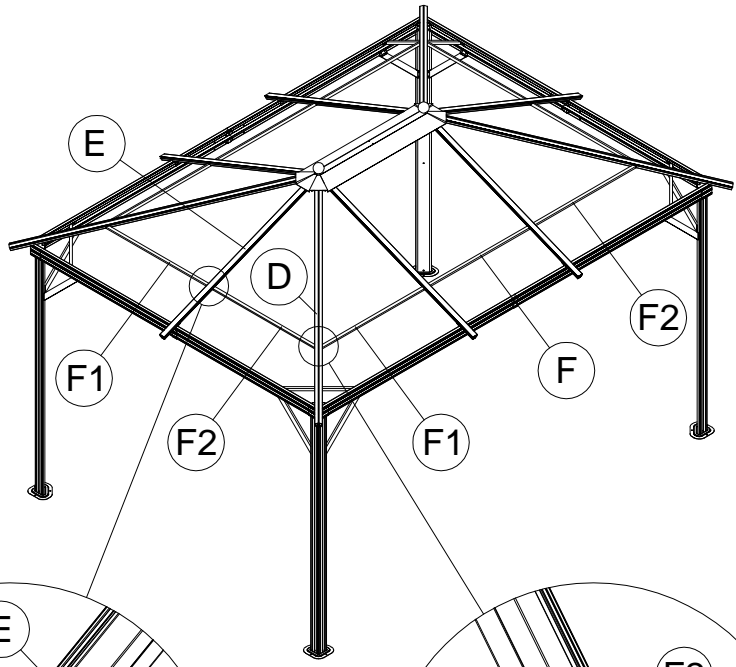

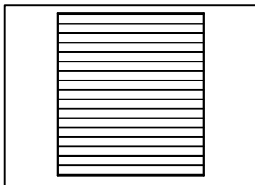

Q 2x

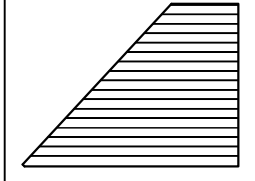

Q1 4x

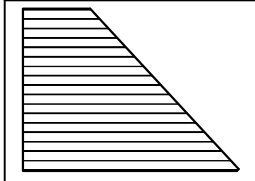

Q2 4x

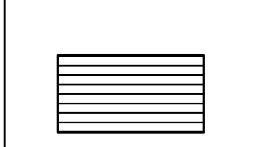

R 2x

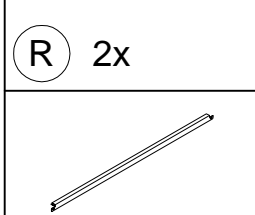

G 2x

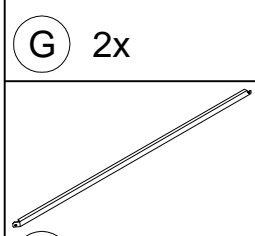

G1 4x

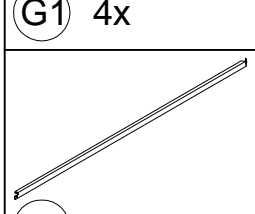

G2 4x

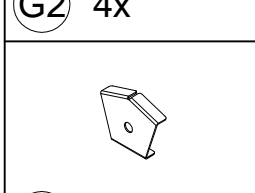

Y 4x

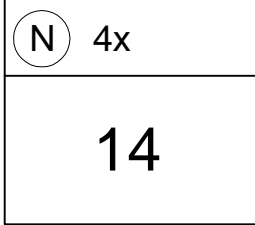

N 4x

14

<12>

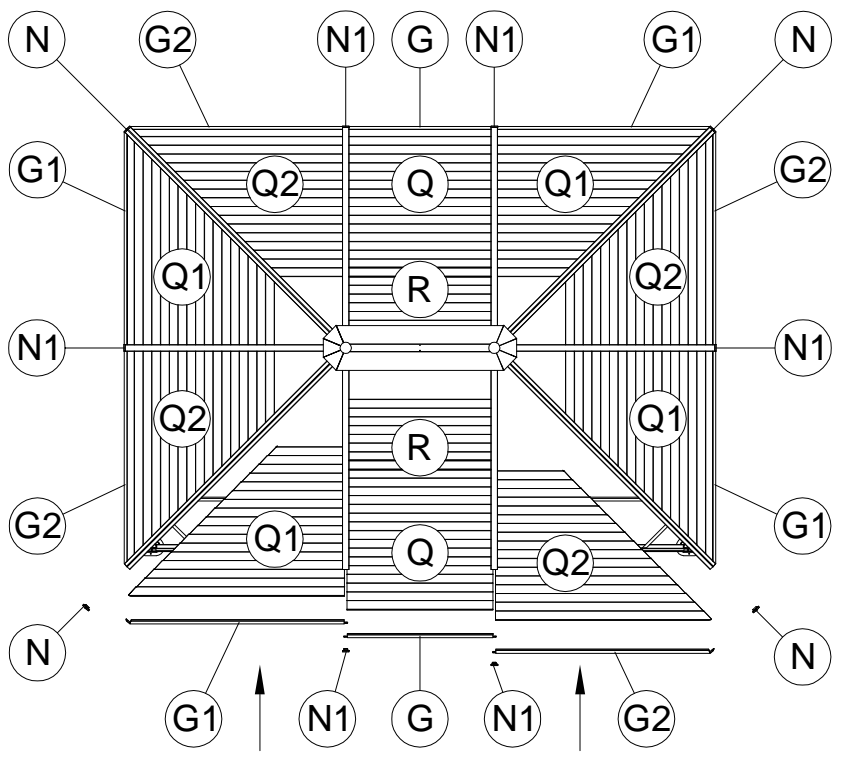
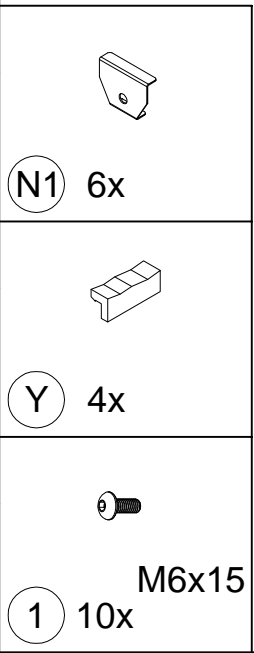
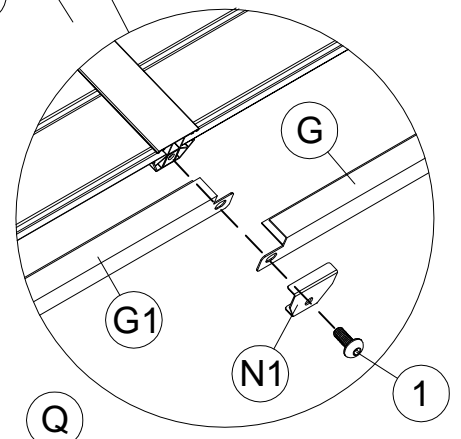
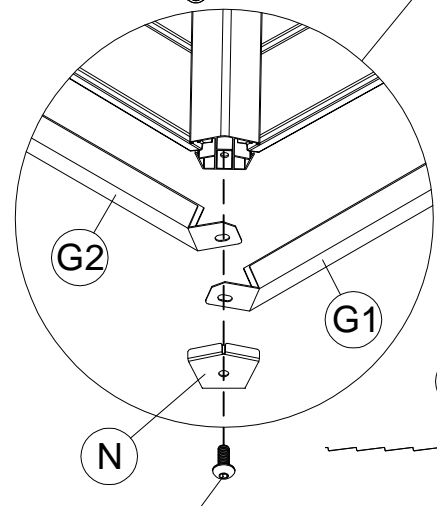
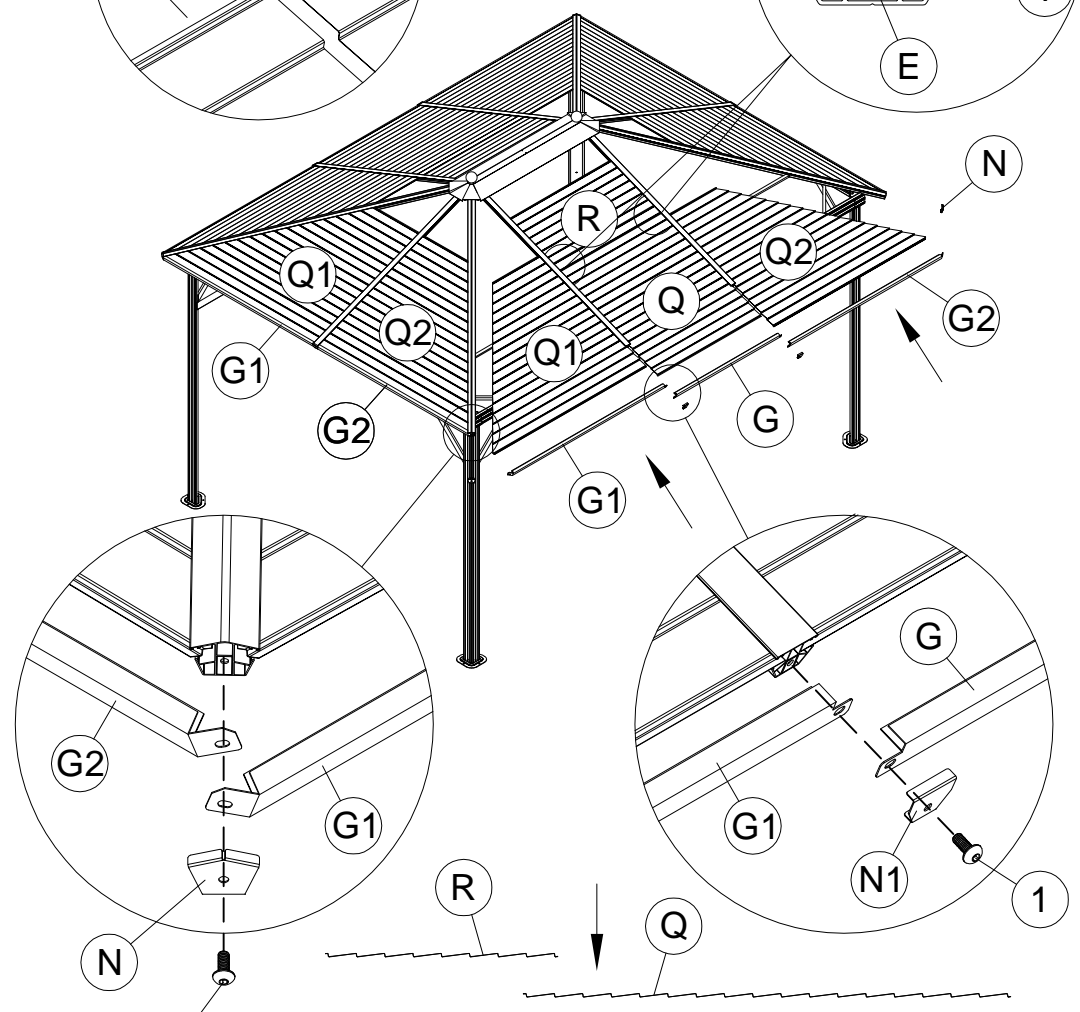
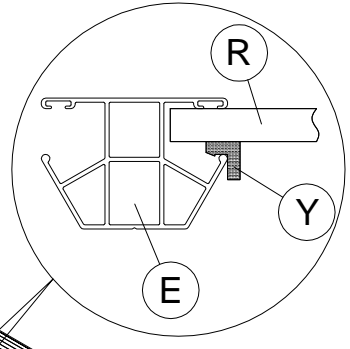
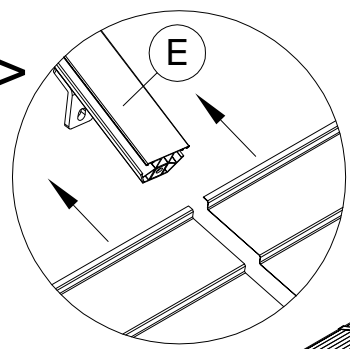



R1 4x



R2 4x

<13>

R1 or R2 or R

Q1 or Q2 or Q

D or E

Y

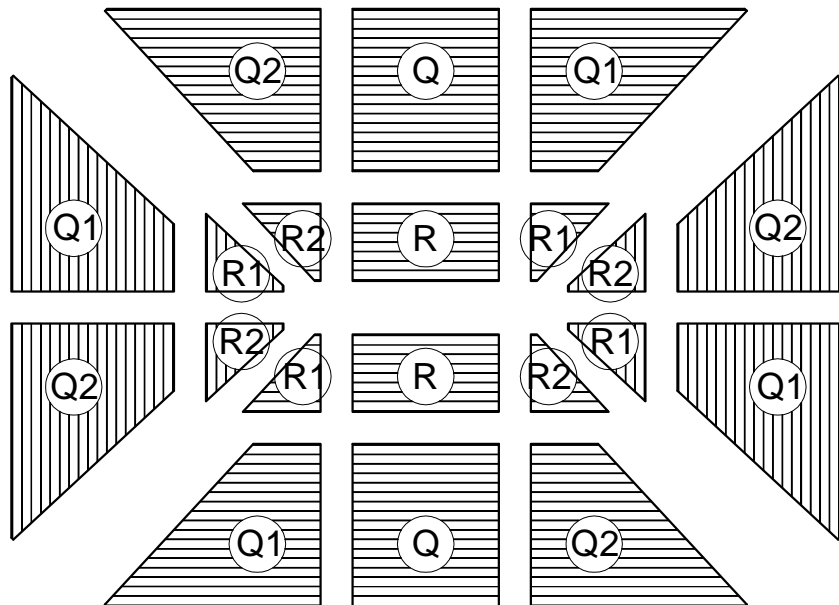
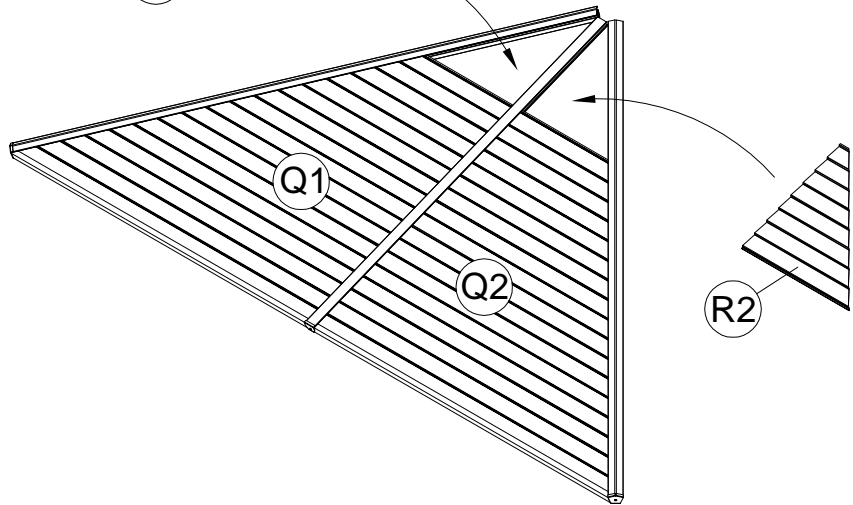
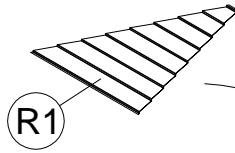



Y 16x

<14>

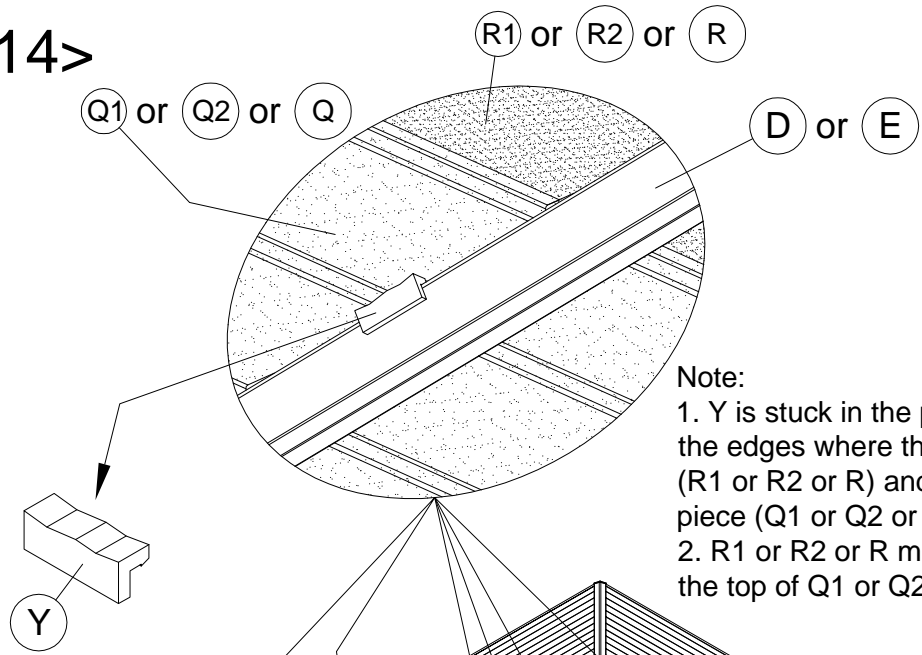

Note:

1. Y is stuck in the position of the edges where the small piece (R1 or R2 or R) and the large piece (Q1 or Q2 or Q) overlap.
2. R1 or R2 or R must pile up on the top of Q1 or Q2 or Q.

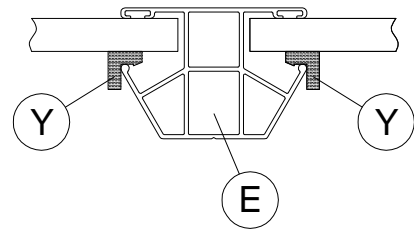
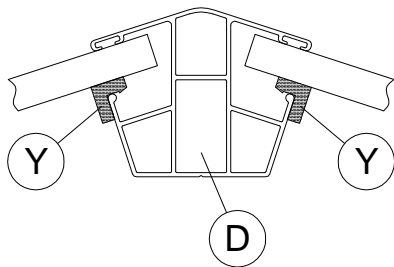
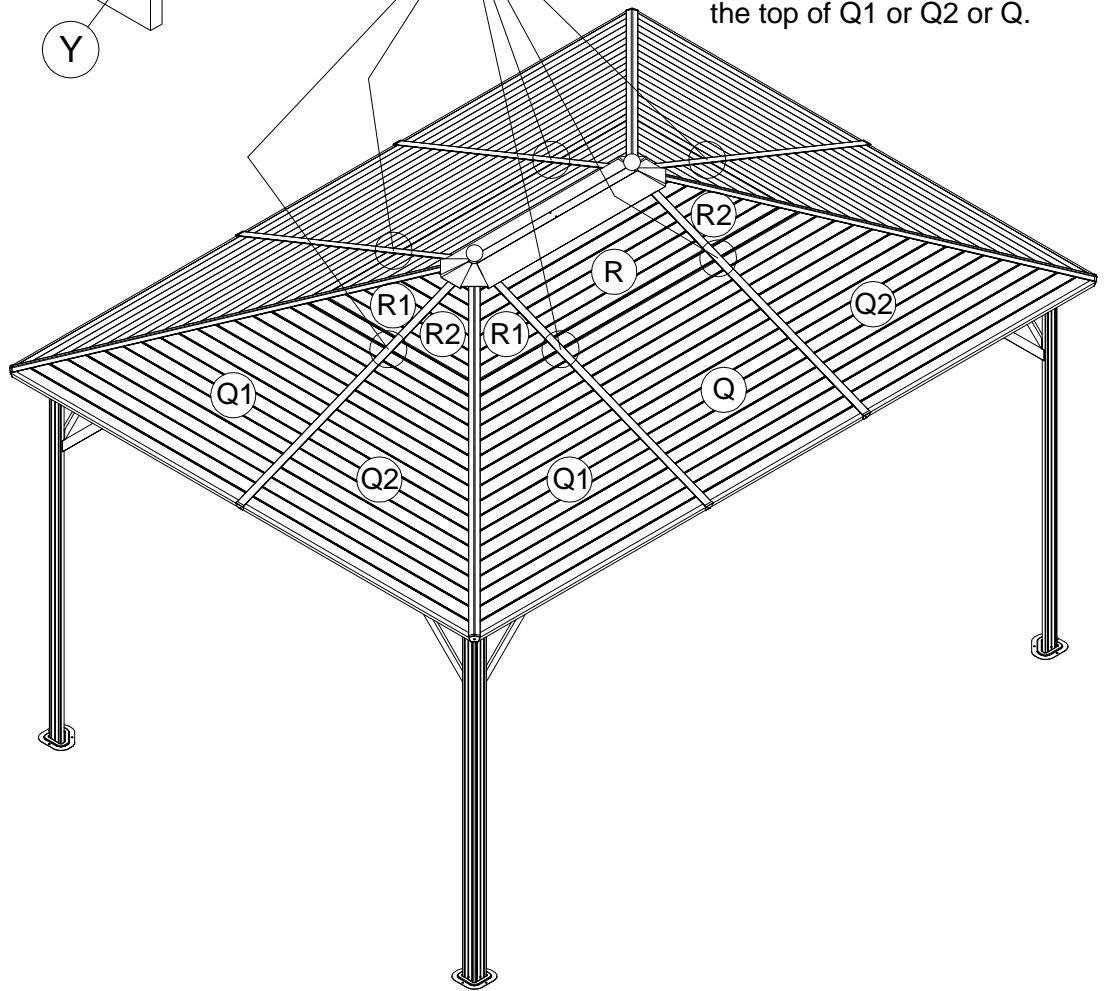

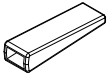

<15>

Y1 12x



7 ST4x8
12x

Note: pls use power tools to drill the screws.

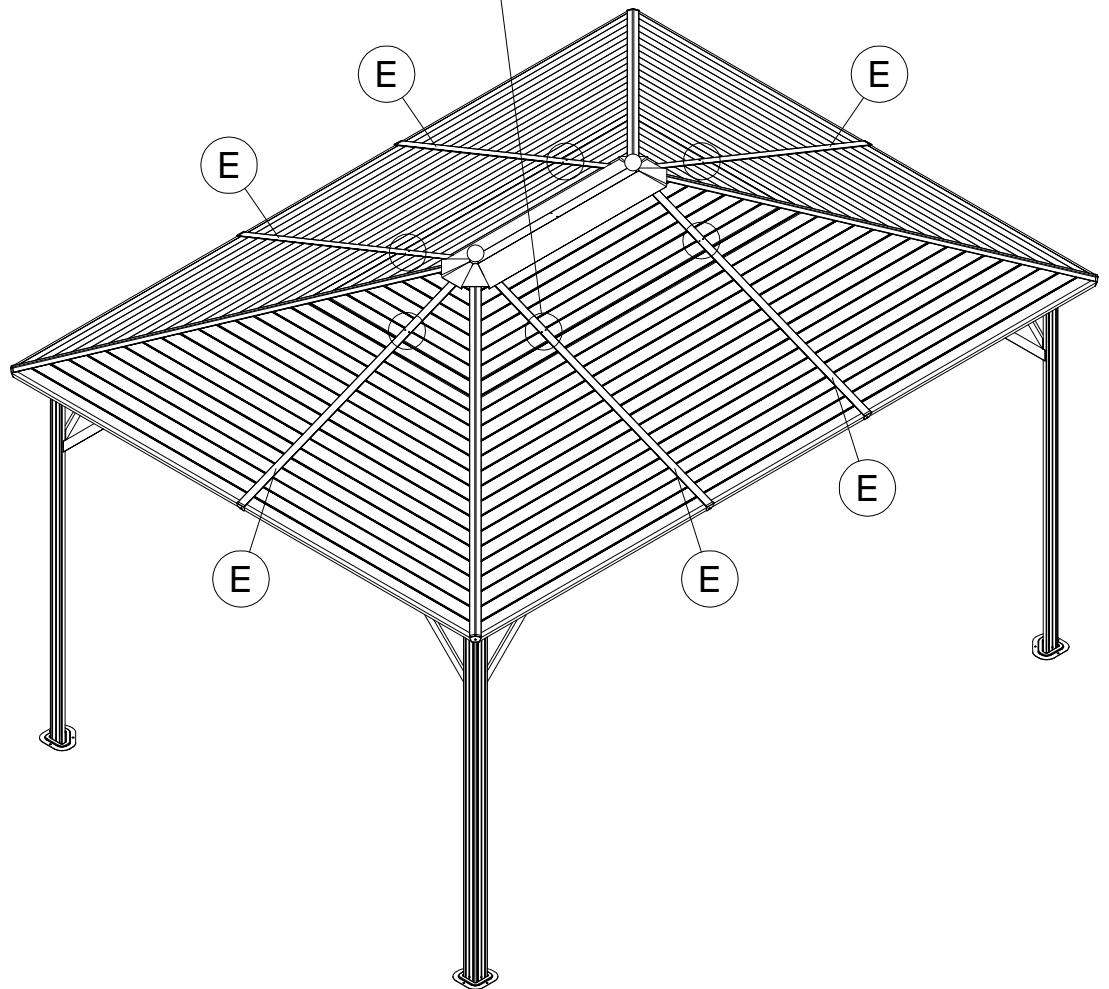
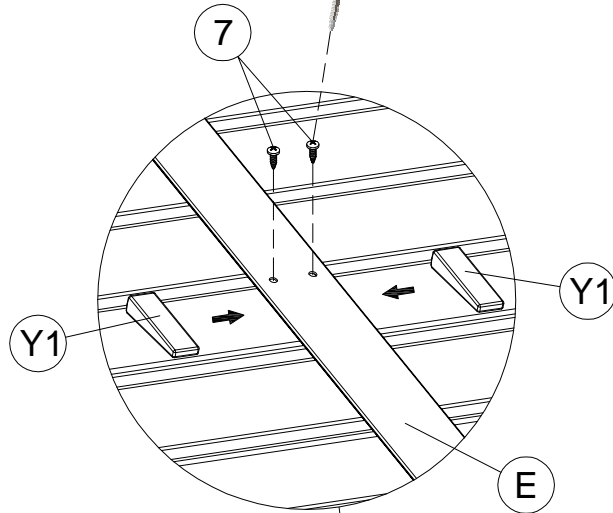

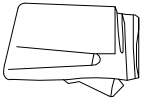

<16>

T 4x

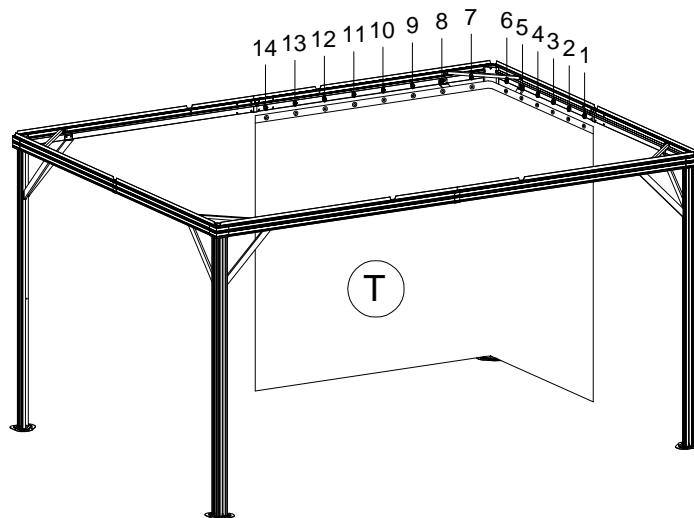
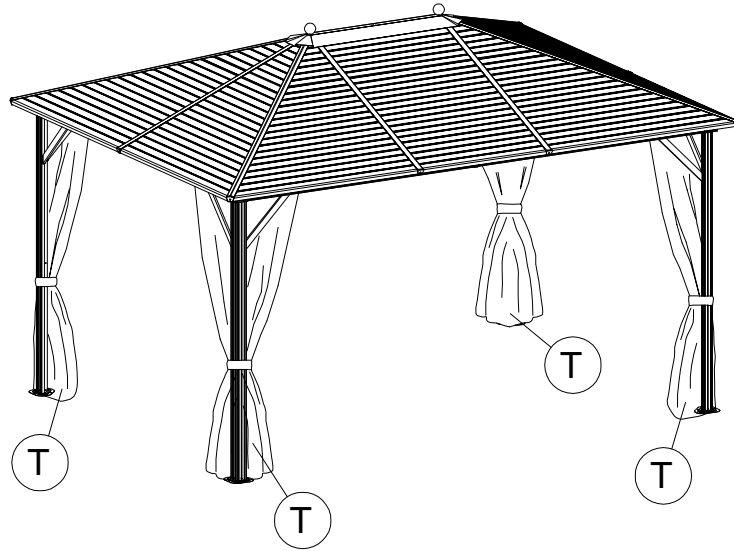
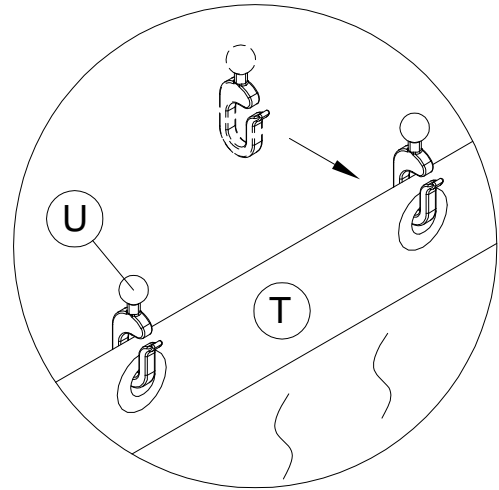
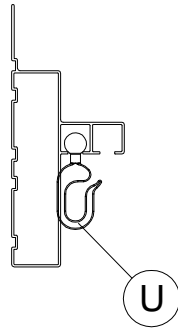

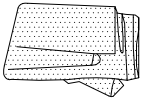

<17>

S 4x

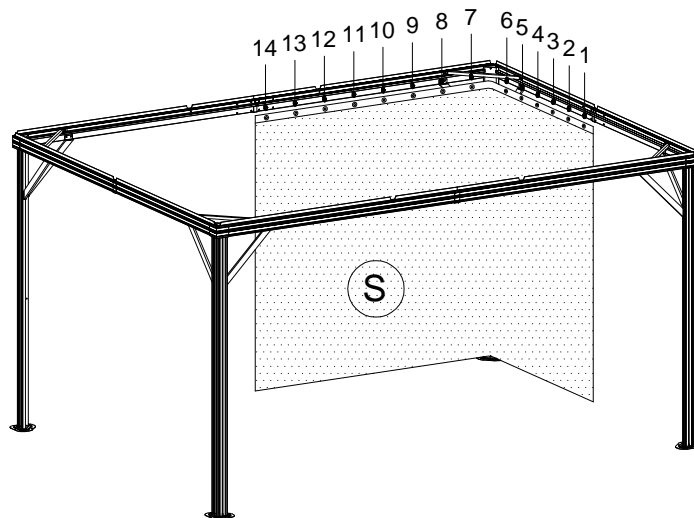
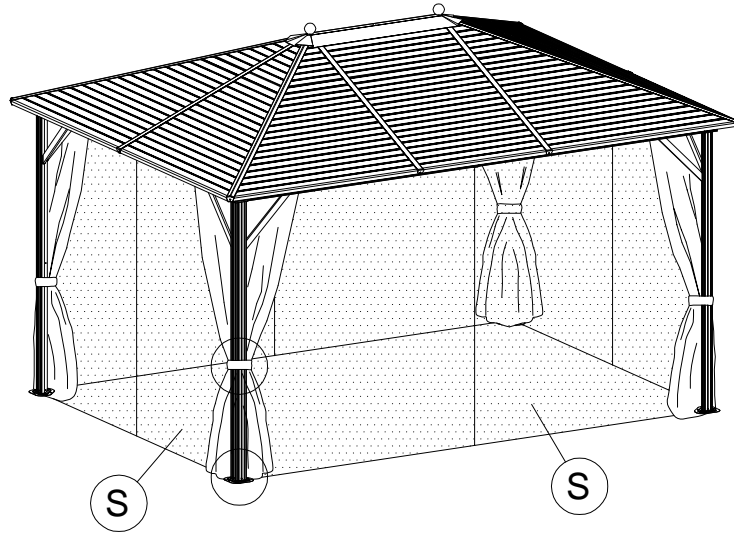
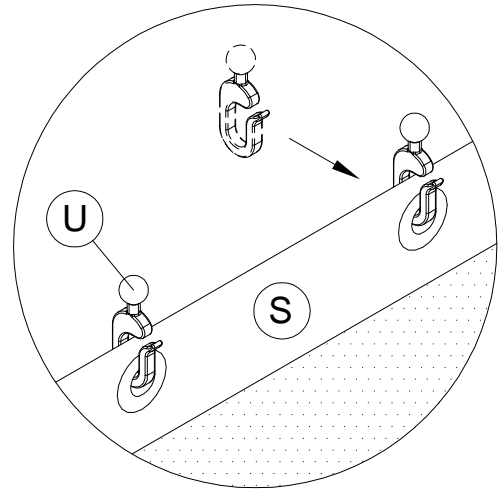
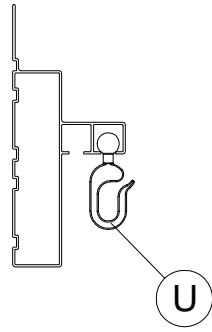



<18>

8 12x

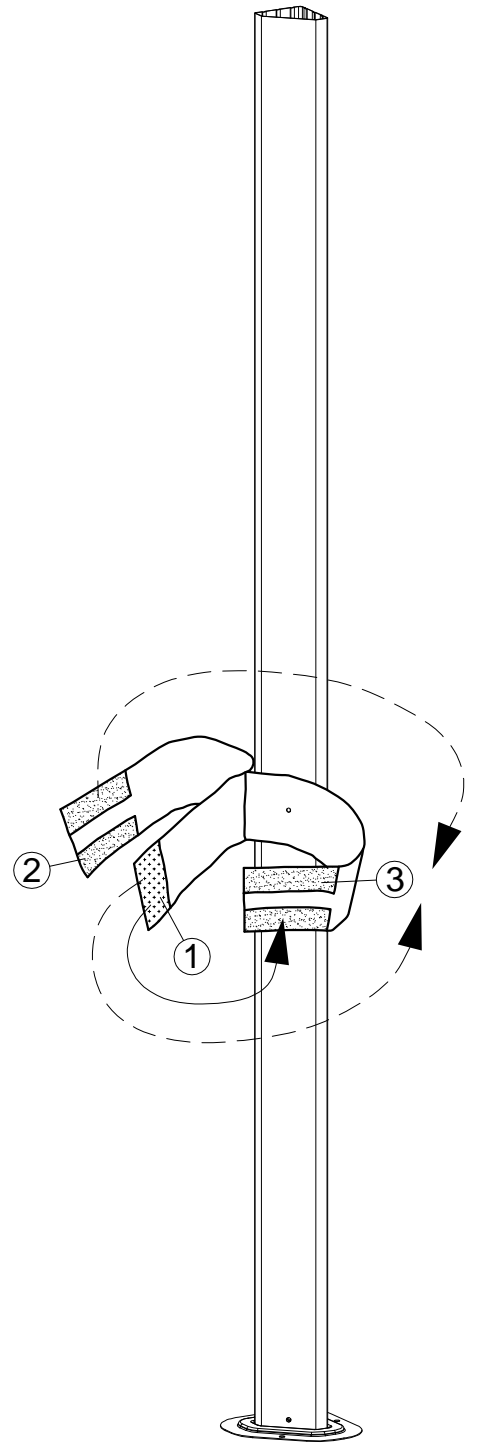
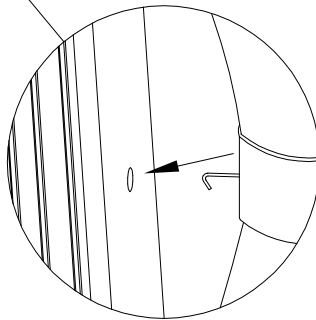
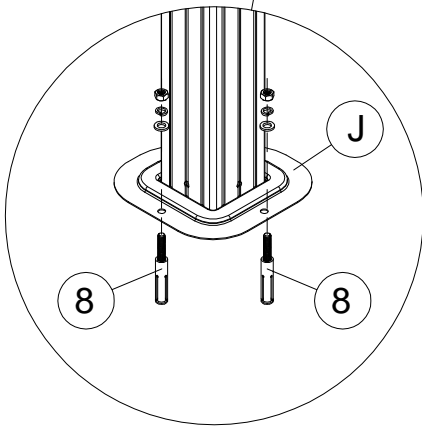
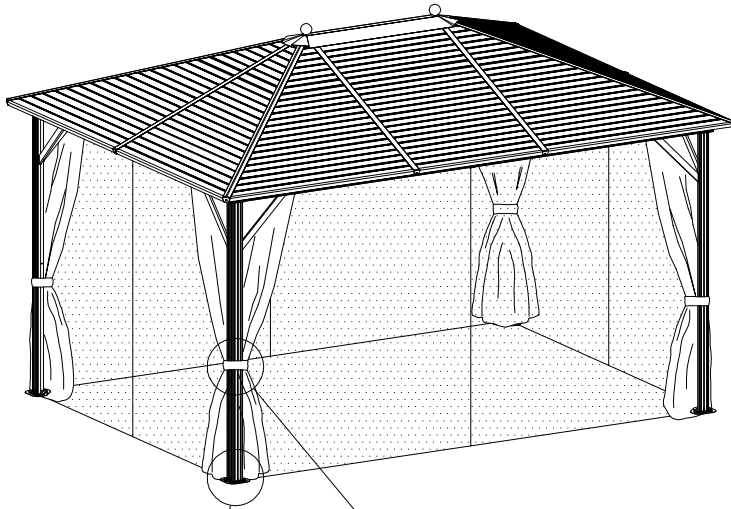

Note:

1. 1 stick 2 tie S and T together
2. 1 stick 3 towards back tie T
3. 1 stick 3 towards front tie S

20