

ASSEMBLY INSTRUCTIONS

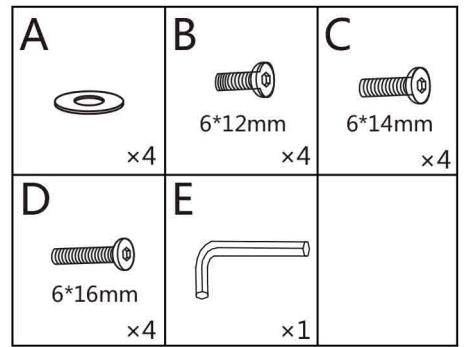

STEP 1 ③ and ④ are connected to ⑤ respectively, B is inserted into the corresponding hole and tightened with E.

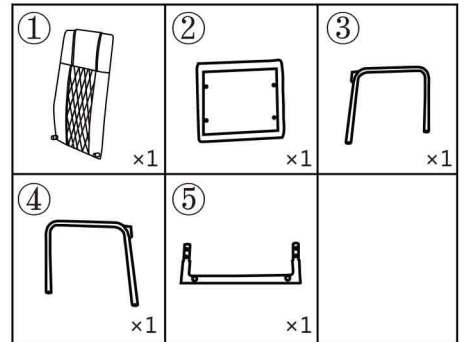
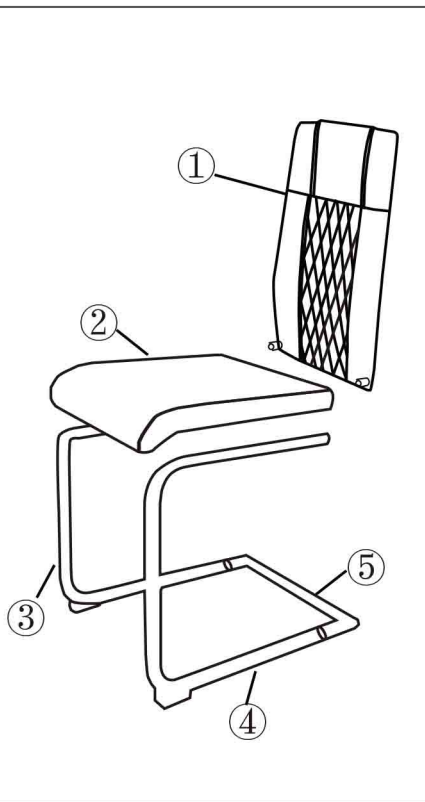
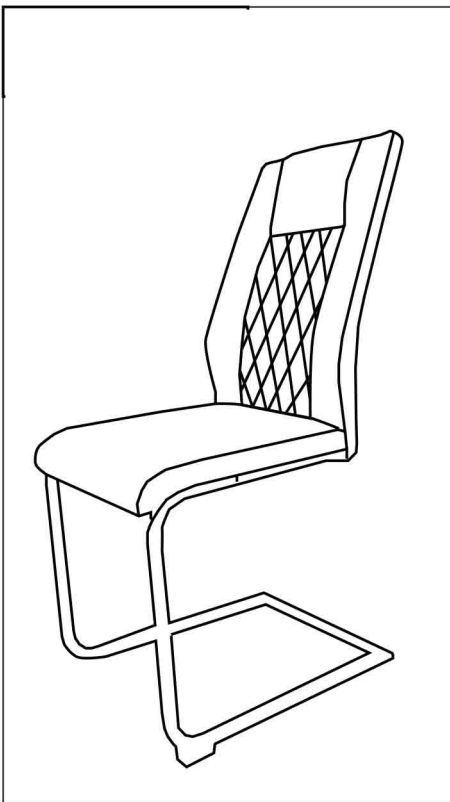
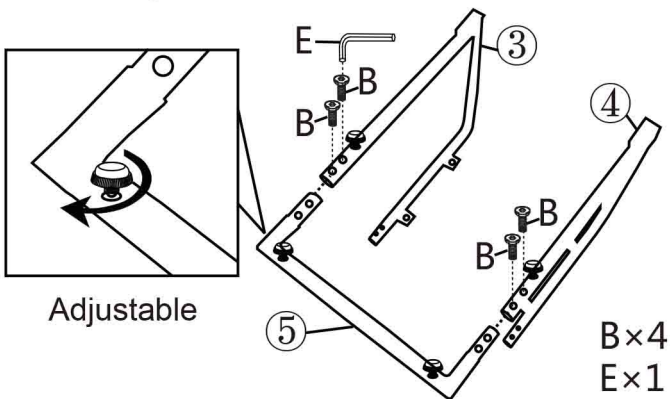

STEP 2 Connect ① to ③ and ④ respectively, insert C into the corresponding hole and tighten with E.

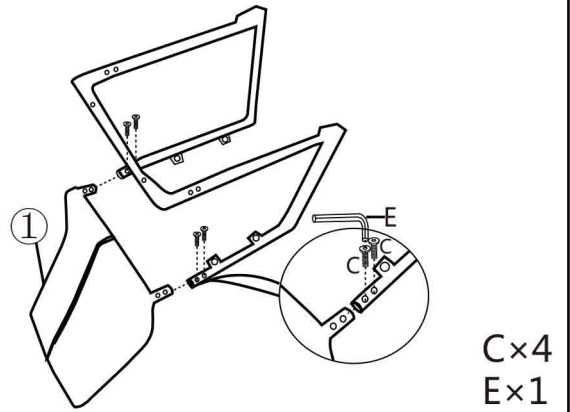

STEP 3 Connect ② to ③ and ④ respectively, insert D and A into the corresponding holes in turn and tighten with E.

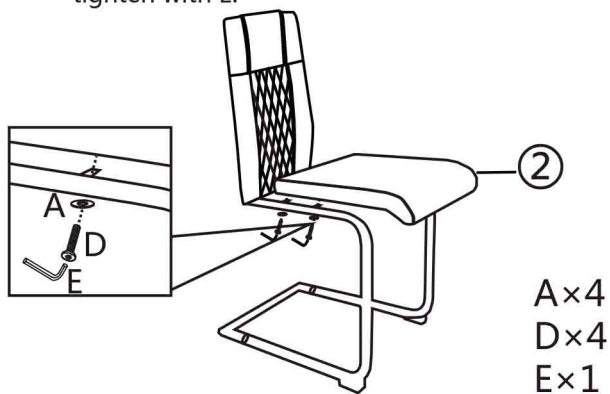

STEP 4 Installation complete

