

INSTALLATION

Product Manual
Description du produit

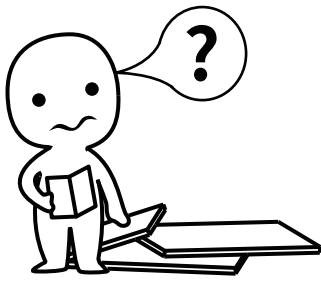

IMPORTANT INFORMATION!

please read the entire manual before starting to assemble and/or using this product follow the manual thoroughly and keep it for further reference.

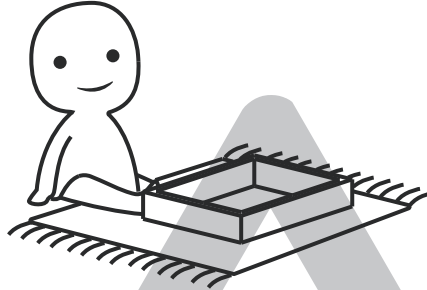
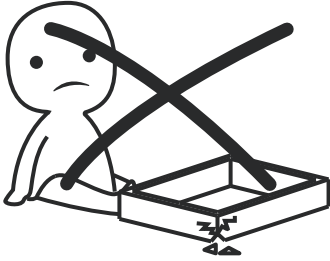

AVOID SCRATCHES!

In order to avoid scratching this furniture should be assembled on a soft layer-could be a rug.

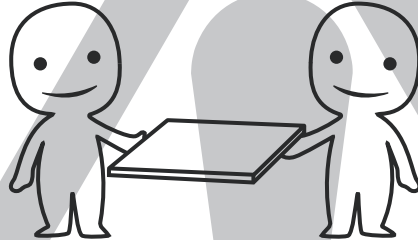

IMPROVE EFFICIENCY !

Try to find a partner to install with you, which can speed up the installation efficiency and shorten the time.

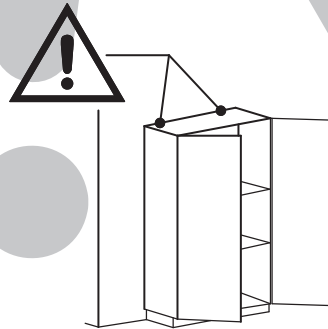
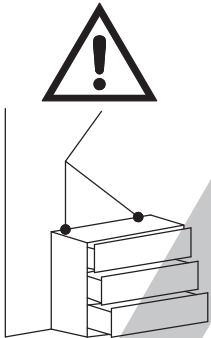

ANTI-TOPPLE WARNING !

Overturnd furniture can cause serious or fatal crush injuries. To prevent tipping over, be sure to use the wall attachment, if not included with this product. Please purchase the wall attachment that fit your wall. If unsure, seek professional advice. Please read and follow each step of the instructions carefully.

IMPORTANT !

It is important that any product which is assembled using any kind of screw is re-tightened 2 weeks after assembly, and once every 3 months - in order to assure stability through-out the lifespan of the product.

For regular maintenance and cleaning of the product, for the frame, please use a rag dipped in neutral detergent to fully wipe it, and then dry it with a clean rag. For glass materials, wipe with a rag dampened with water glass cleaner, and then dry with a dry rag.

Do not use an electric screwdriver, and do not use too much force when installing, because the board is easy to break.

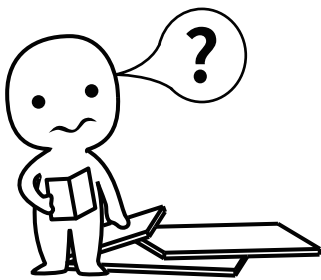

AVERTISSEMENT!

Veillez lire le manuel en entier avant de commencer à assembler et/ou à utiliser ce produit. Suivez attentivement le manuel et conservez-le pour référence ultérieure.

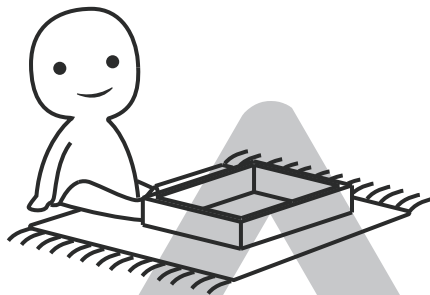
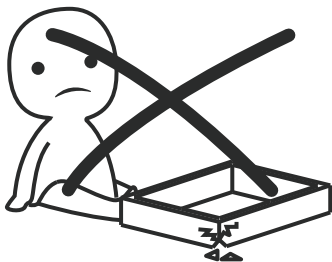

ÉVITEZ LES RAYURES!

Afin d'éviter de rayer ce meuble doit être assemblé sur une couche souple - pourrait être un tapis.

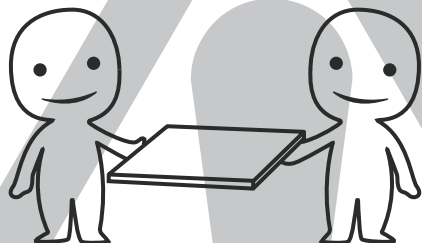

AMÉLIORER L'EFFICACITÉ !

Essayez de trouver un partenaire à installer avec vous, ce qui peut accélérer l'efficacité de l'installation et raccourcir le temps.

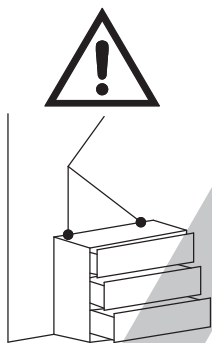

AVERTISSEMENT ANTI-RENVERSEMENT !

Les meubles renversés peuvent causer des blessures graves ou mortelles par écrasement. Pour éviter de basculer, assurez-vous d'utiliser la fixation murale, si elle n'est pas incluse avec le produit. Veillez acheter la fixation murale qui s'adapte à votre mur. En cas de doute, demandez conseil à un professionnel. Veillez lire et suivre attentivement chaque étape des instructions.

IMPORTANT !

Il est important que tout produit assemblé à l'aide de tout type de vis soit resserré 2 semaines après l'assemblage et une fois tous les 3 mois, afin d'assurer la stabilité tout au long de la durée de vie du produit.

Pour l'entretien régulier et le nettoyage du produit, pour le cadre, veuillez utiliser un chiffon trempé dans un détergent neutre pour l'essuyer complètement, puis séchez-le avec un chiffon propre. Pour les matériaux en verre, essuyez avec un chiffon imbibé d'eau nettoyant pour vitres, puis séchez avec un chiffon sec.



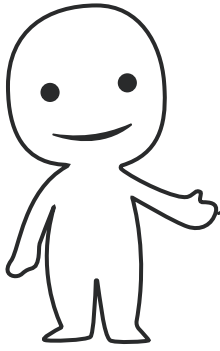



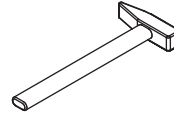
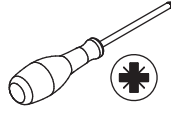
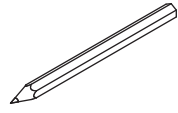



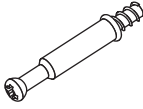

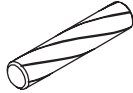
N'utilisez pas de tournevis électrique et n'utilisez pas trop de force lors de l'installation, car la carte est facile à casser.

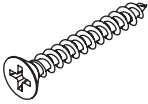
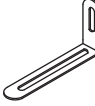
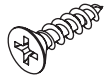
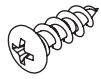

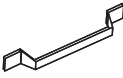
Please prepare the following tools
Veuillez préparer les outils suivants

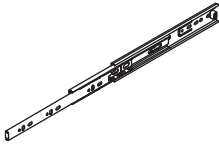

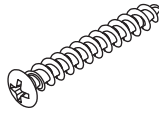
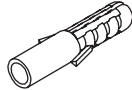
When installing, please carefully confirm whether each screw corresponds to the manual, accessories with similar shapes can be distinguished by size
Lors de l'installation, veuillez vérifier soigneusement si chaque vis correspond au manuel. Les accessoires de forme similaire peuvent être distingués par leur taille.

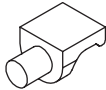
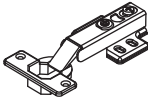
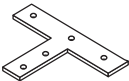
A x 60+4  Ø6 x 35 mm	B x 60+4  Ø15 x 10 mm	C x 35+3  Ø6 x 30 mm	D x 12+1  Ø6 x 50 mm	E x 31+3  Ø4 x 35mm
F x 2 	G x 84+4  Ø4 x 12 mm	H x 2+1  Ø4 x 12 mm	J x 89+4  Ø3 x 14 mm	K x 9 
L x 18+2  Ø4 x 12 mm	M x 6 	N x 36+4  Ø3 x 10 mm	Q x 2  Ø4 x 40 mm	R x 2  Ø6 x 30 mm
S x 4 	T x 12+1 	U x 10 	V x 2 	

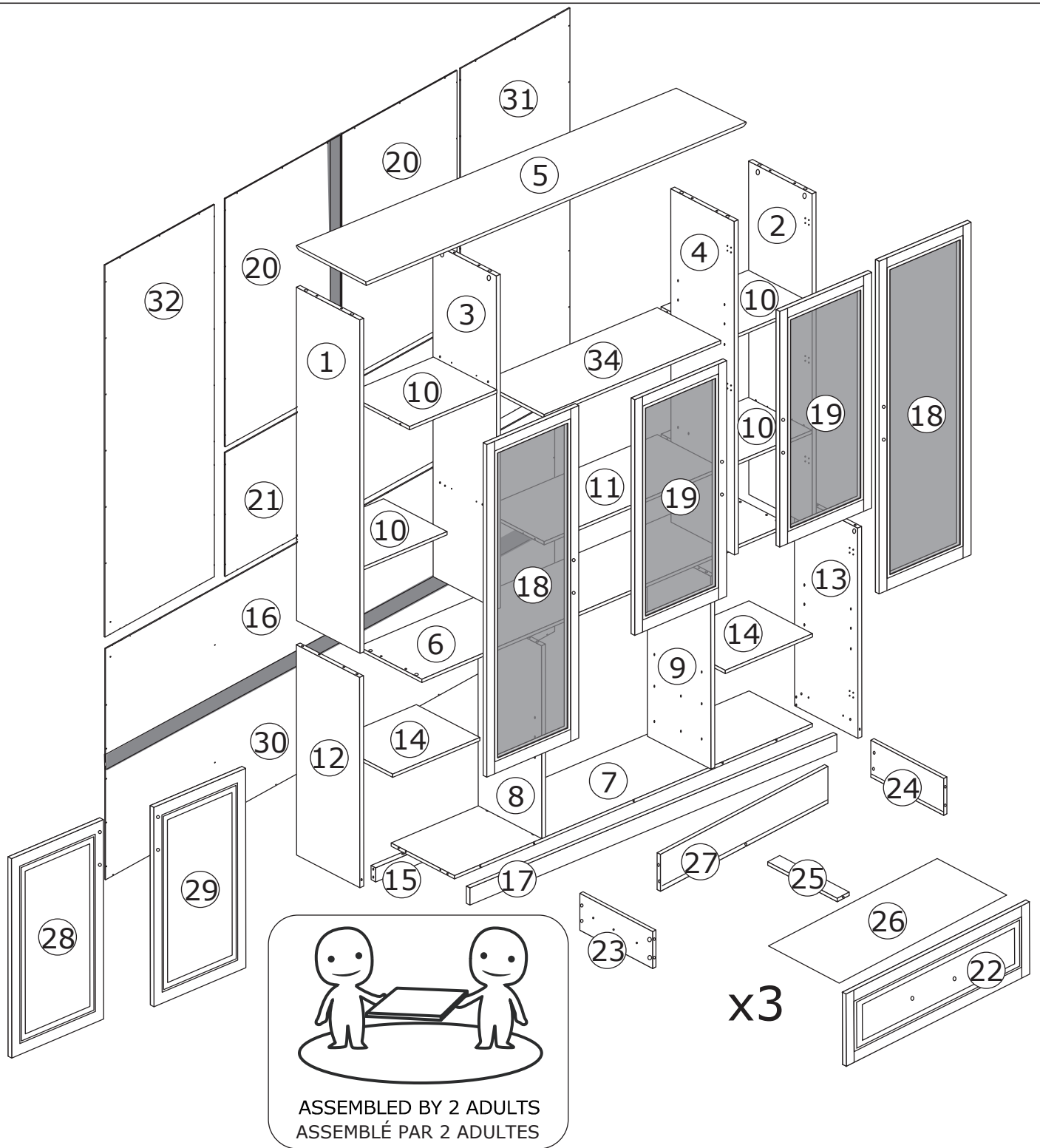

⚠ WARNING

Children have died from furniture tipover. To reduce the risk of furniture tipover:

- ALWAYS install Anti-tip device provided.
- NEVER put a TV on this product.
- NEVER allow children to stand, climb or hang on any drawers, doors, or shelves.
- NEVER open more than one drawer at a time.
- Place heaviest items in the lowest drawers.

This is a permanent label. Do not remove!

⚠ AVERTISSEMENT

Des enfants sont morts à la suite du renversement d'un meuble. Pour réduire le risque de basculement du meuble :

- TOUJOURS installer le dispositif anti-basculement fourni.
- N'installez jamais un téléviseur sur ce produit.
- NE jamais permettre aux enfants de se tenir debout, de grimper ou de s'accrocher aux tiroirs, aux portes ou aux étagères.
- N'ouvrez jamais plus d'un tiroir à la fois.
- Placez les objets les plus lourds dans les tiroirs les plus bas.

Il s'agit d'une étiquette permanente. Ne l'enlevez pas !

**Slides Must Be Separated Before Assembly.
After Separated, Set Aside Until Needed for Assembly.**

Les glissières doivent être séparées avant l'assemblage.
Après la séparation, mettez de côté jusqu'au moment de l'assemblage.

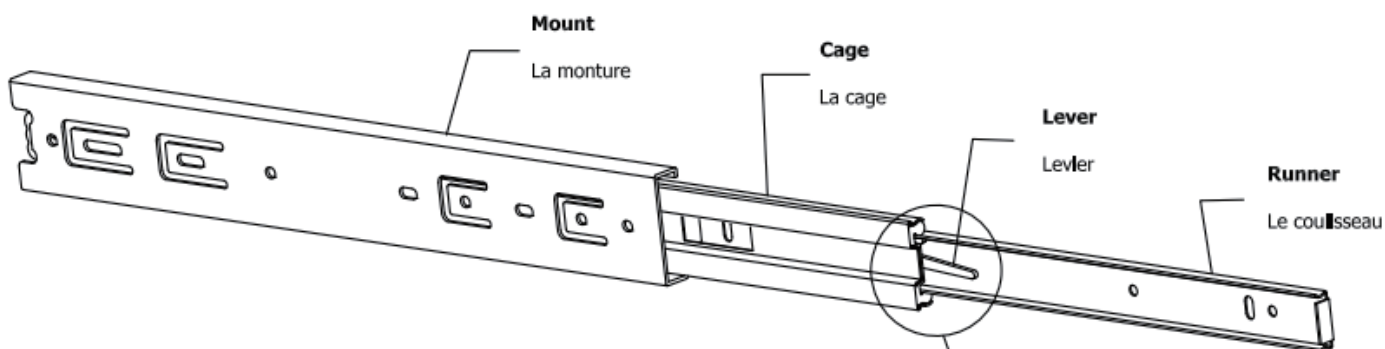

STEP 1: Extend Slide

Extendre la diapositive

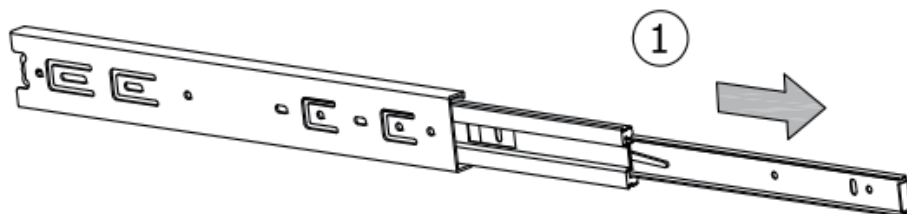

STEP 2: Push Lever UP

Lever le levier

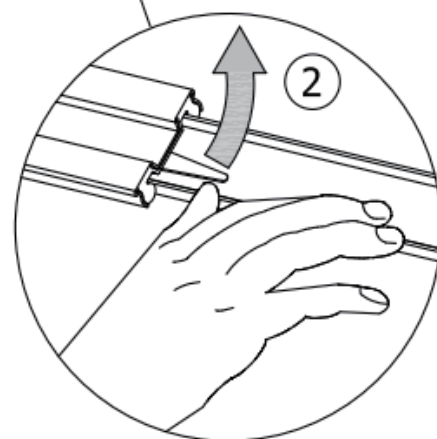

STEP 3: Remove Runner

Enlever le coureur

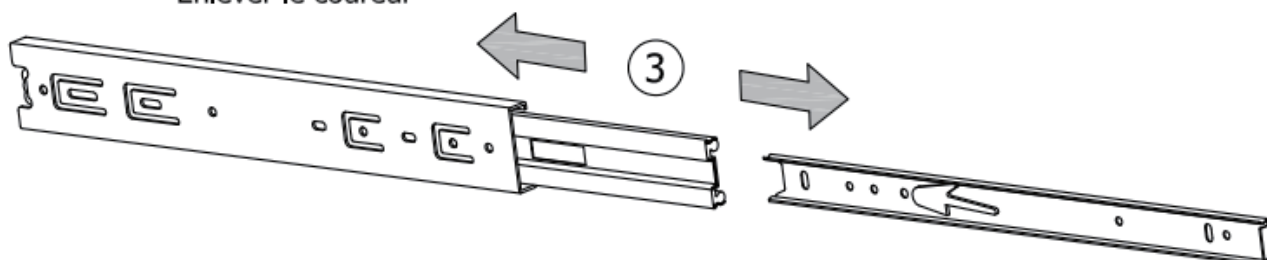

1

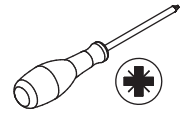
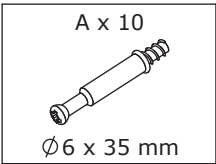

Insert quickfit screw(A) into plate 7,
2 and 1 as shown.

Insérer la vis rapide (A) dans les
plaques 7, 2 et 1 comme indiqué.

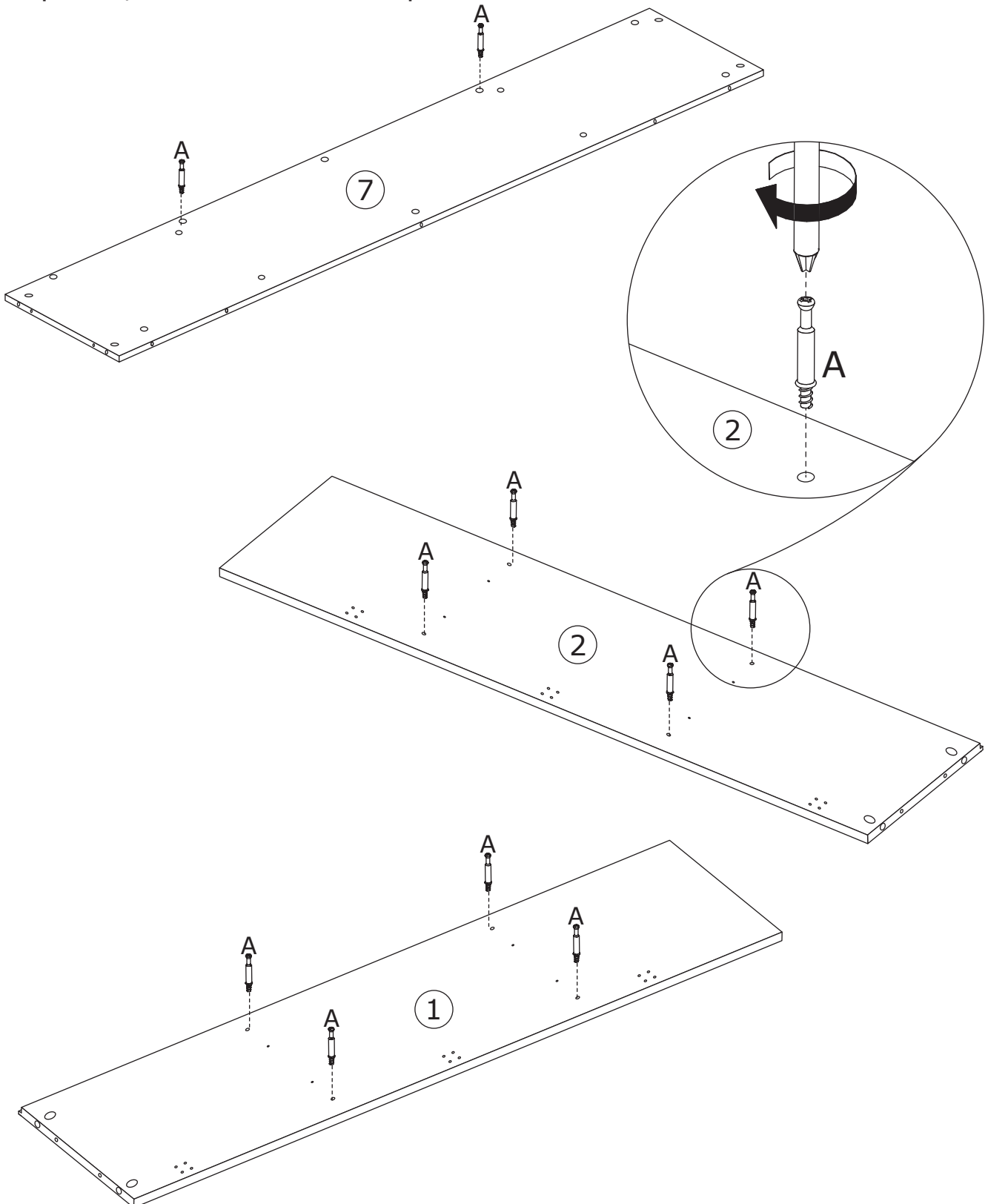
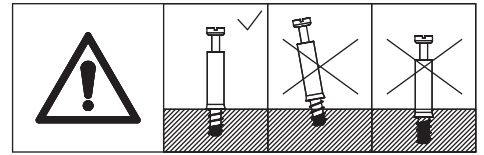

2

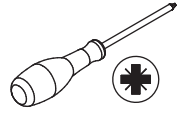
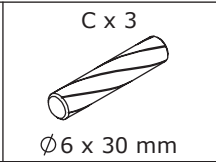
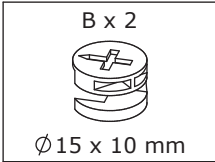

Knock wooden dowel(C) into plate 7,
then attach plate 15 to.
Add cam lock(B) into plate 15, turn
clockwise to tighten as shown.

Frapper la cheville en bois (C) dans la plaque
7, puis fixer la plaque 15.
Ajoutez le verrou à came(B) dans la plaque
15, tournez dans le sens des aiguilles d'une
montre pour serrer comme indiqué.

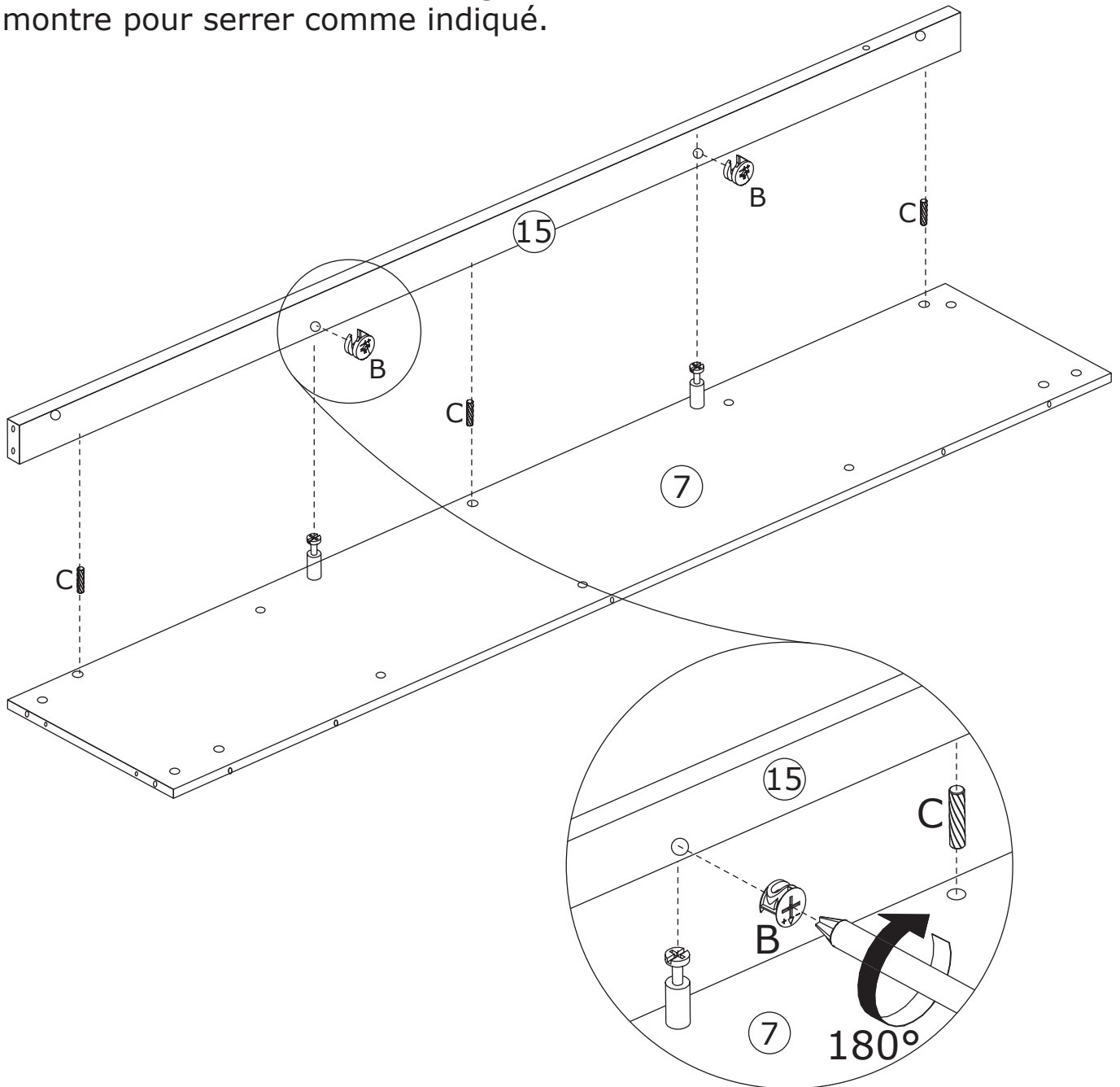
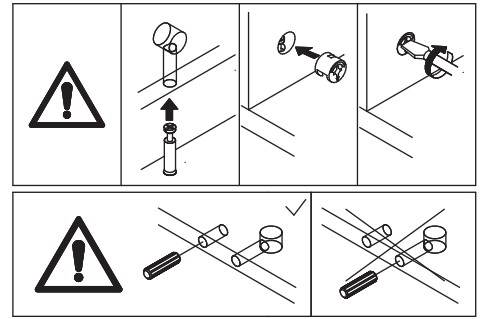

3

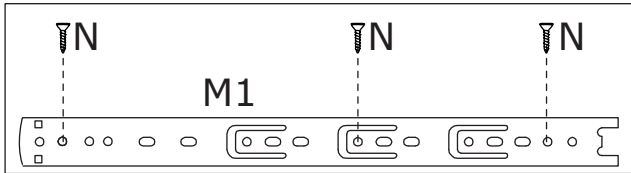
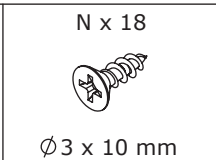
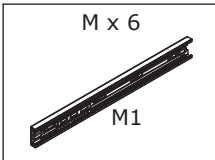

Fix slide rail(M1)to plate 8 and 9 with screw(N) as shown.

Fixer la glissière (M1) aux plaques 8 et 9 à l'aide de vis (N) comme indiqué.

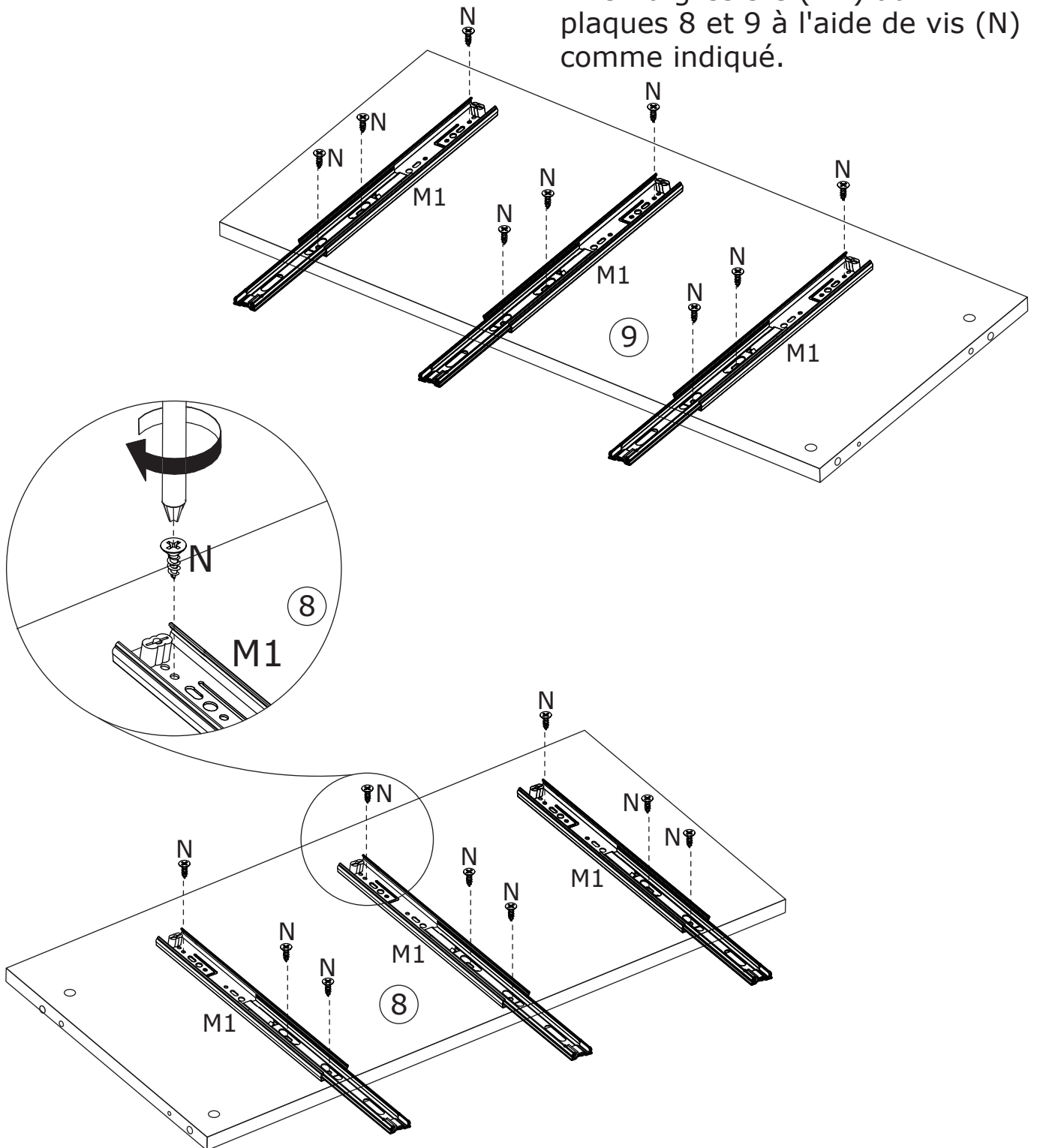

4

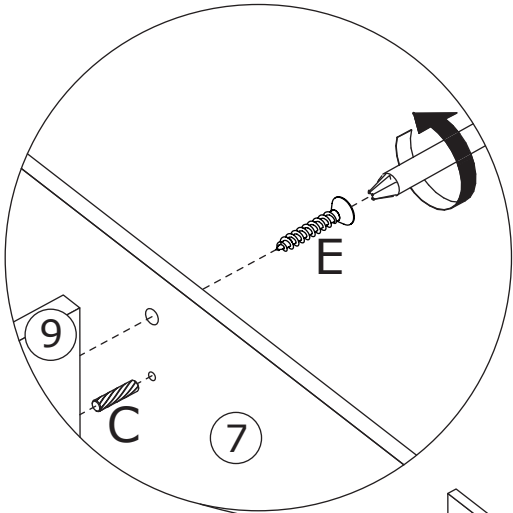
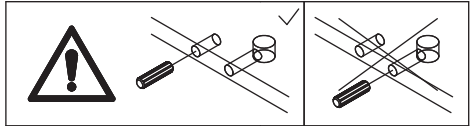
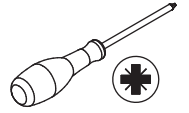
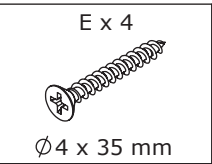
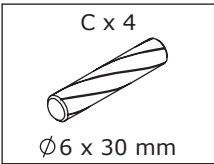

Knock wooden dowel(C) into plate 8 and 9, then attach to plate 7 and fix with screw(E) as shown.

Frappez la cheville en bois (C) dans les plaques 8 et 9, puis fixez-la à la plaque 7 et fixez-la à l'aide de la vis (E) comme indiqué.

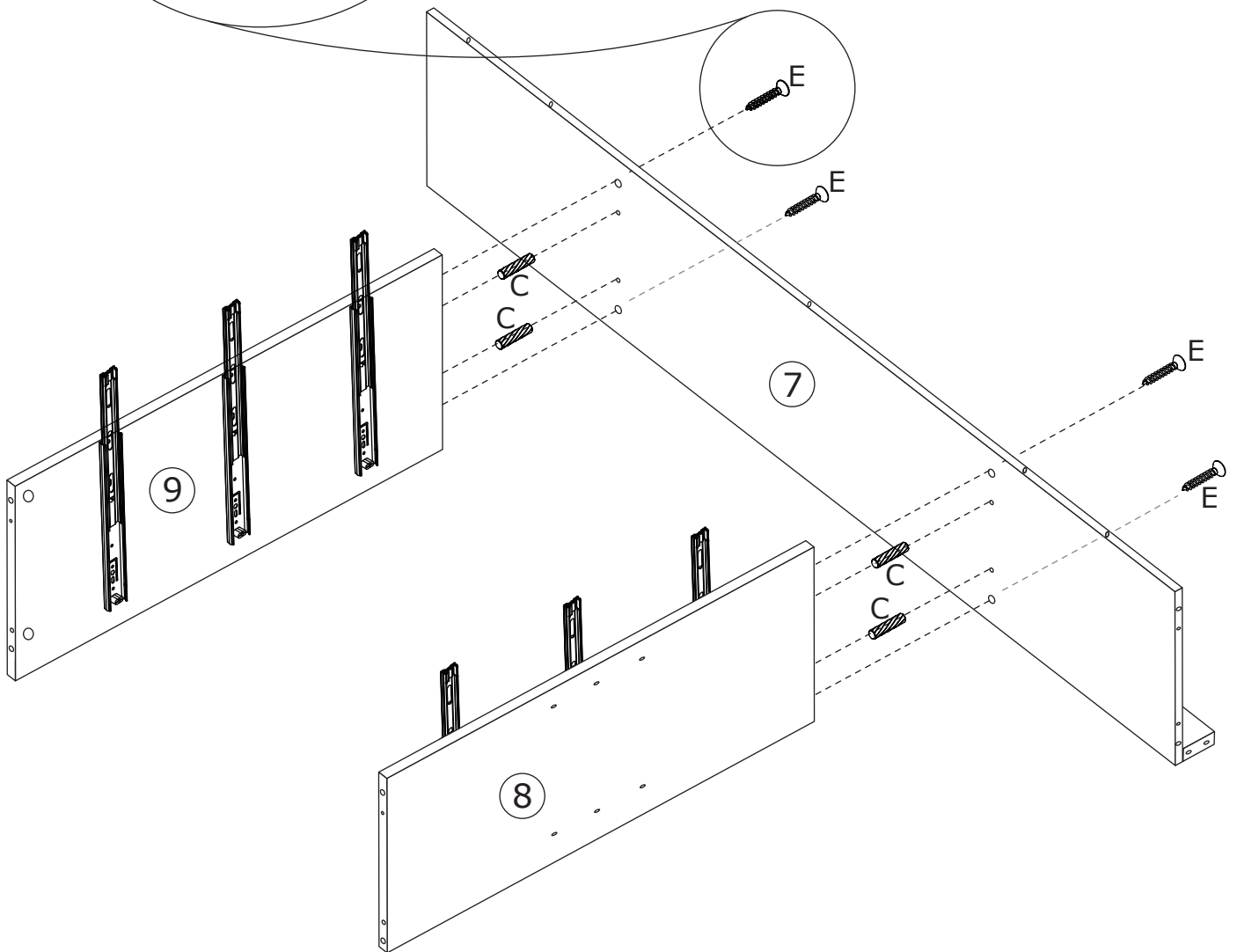

5

A x 6
Ø6 x 35 mm

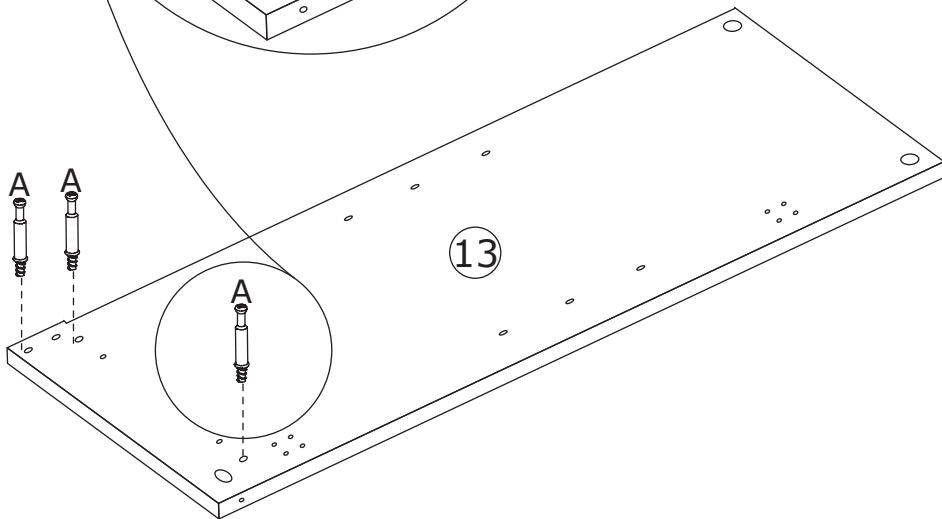
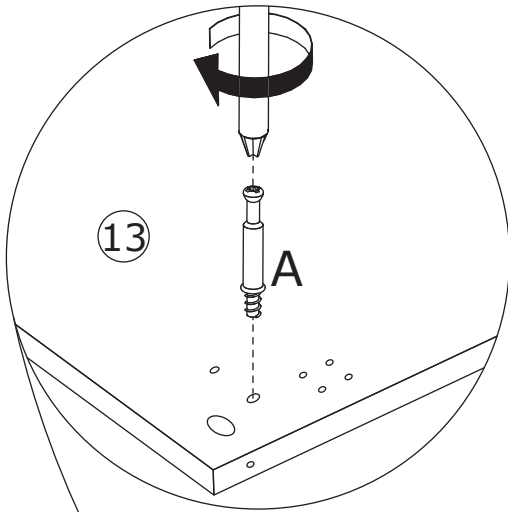
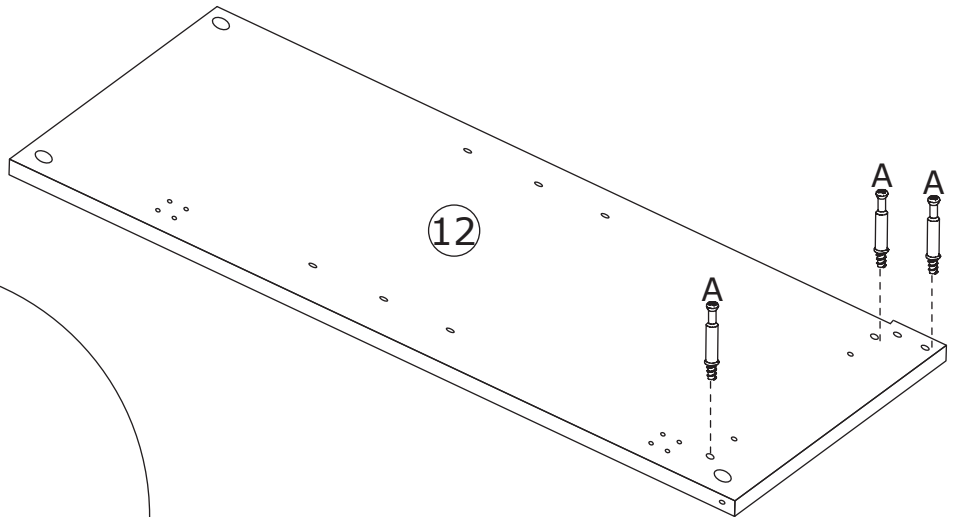
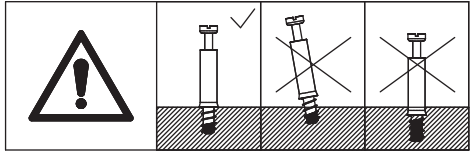
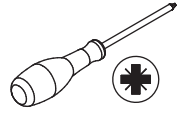

6

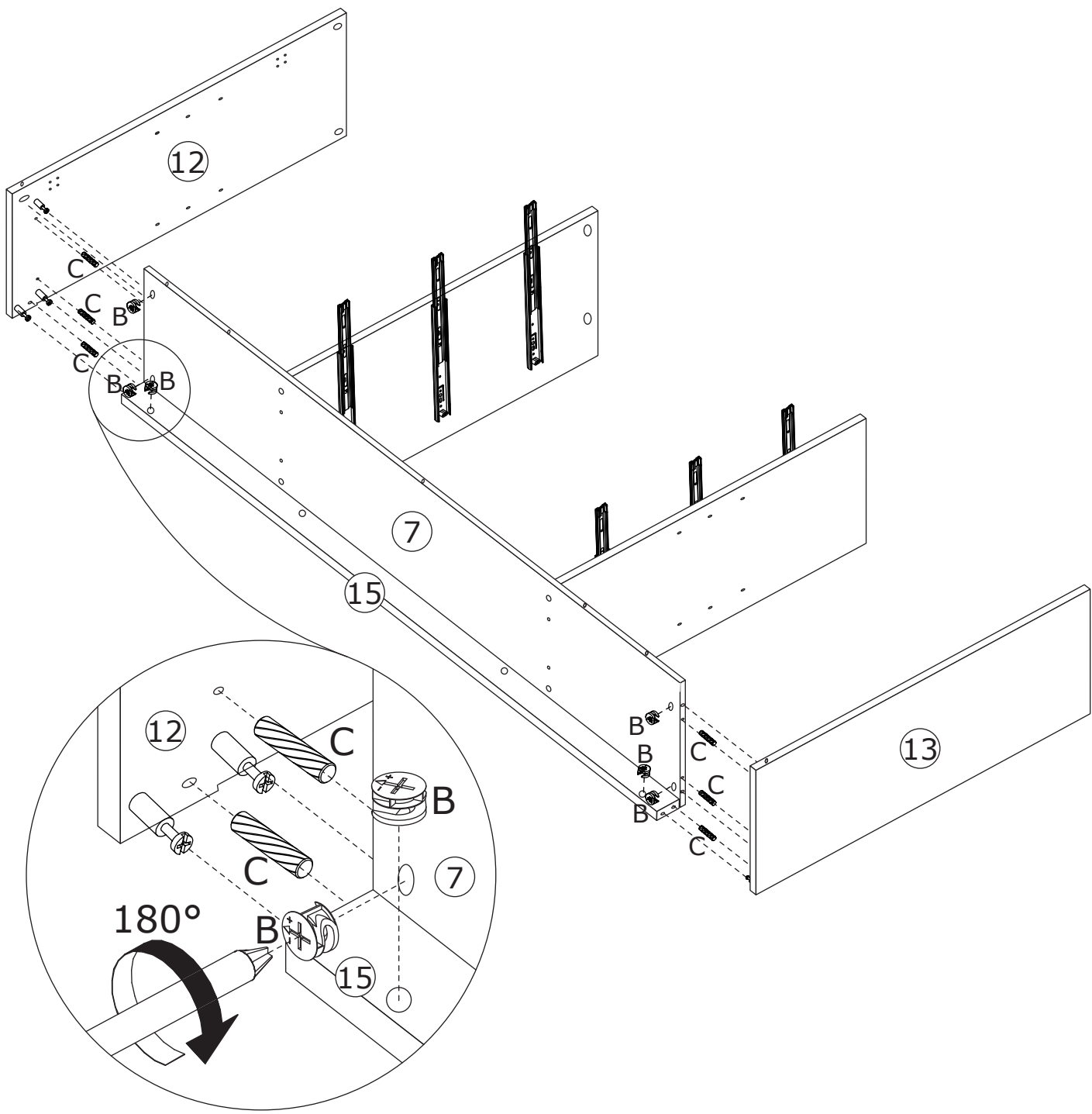
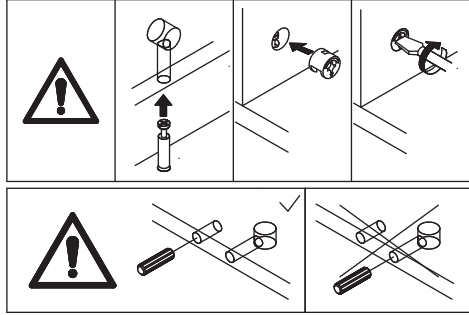
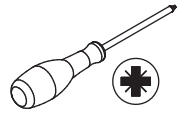
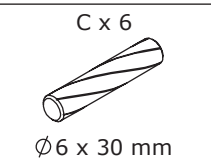
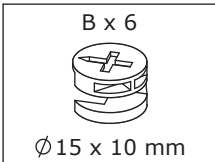

7

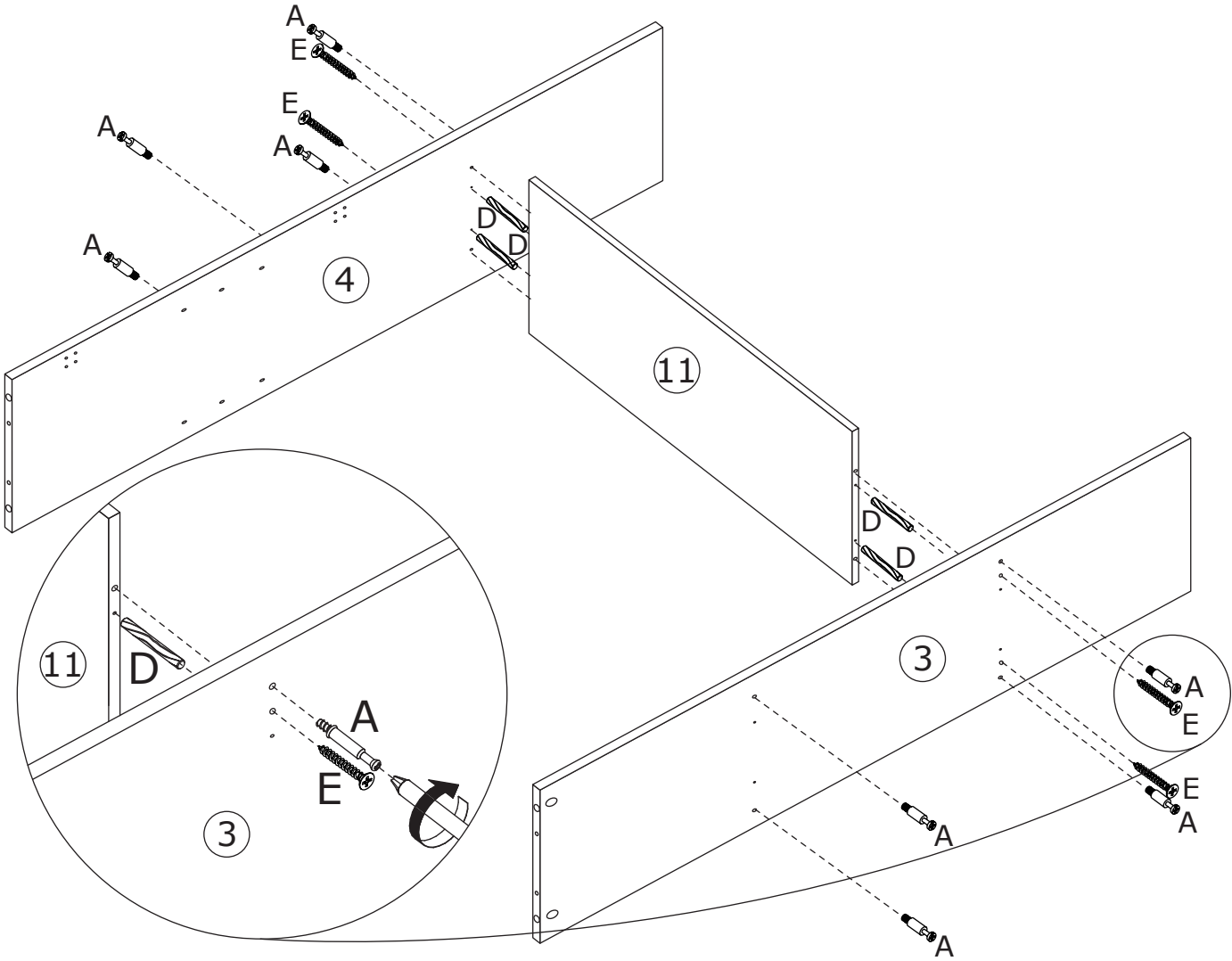
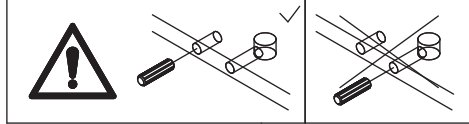
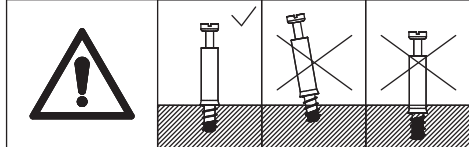
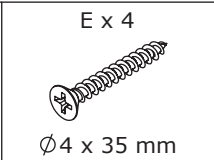
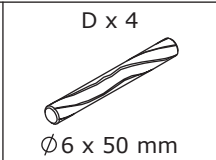
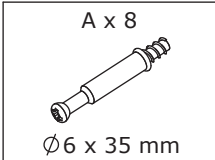

8

B x 8
Ø15 x 10 mm

C x 4
Ø6 x 30 mm

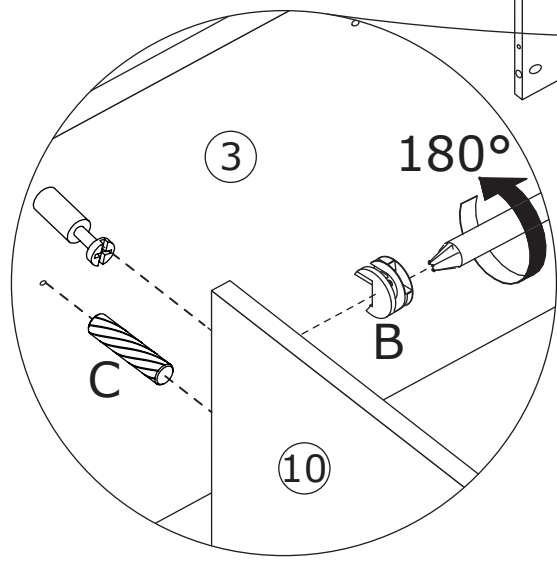
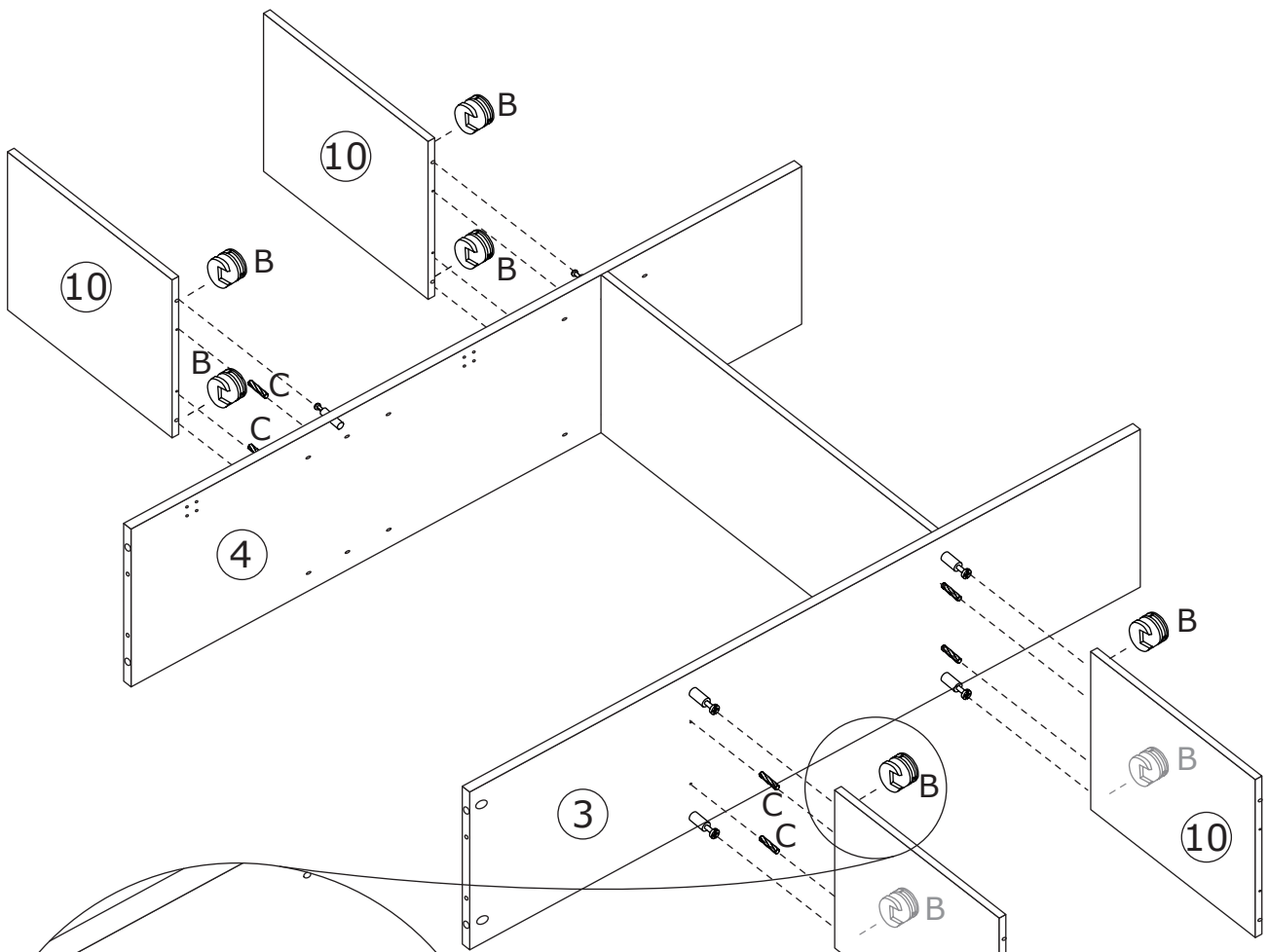
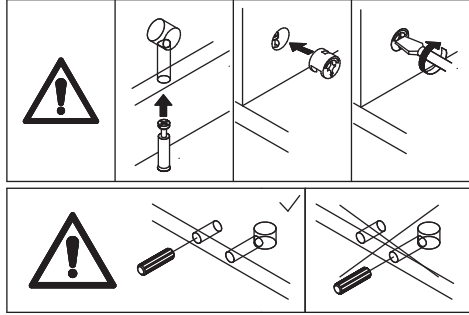
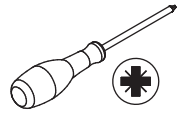

9

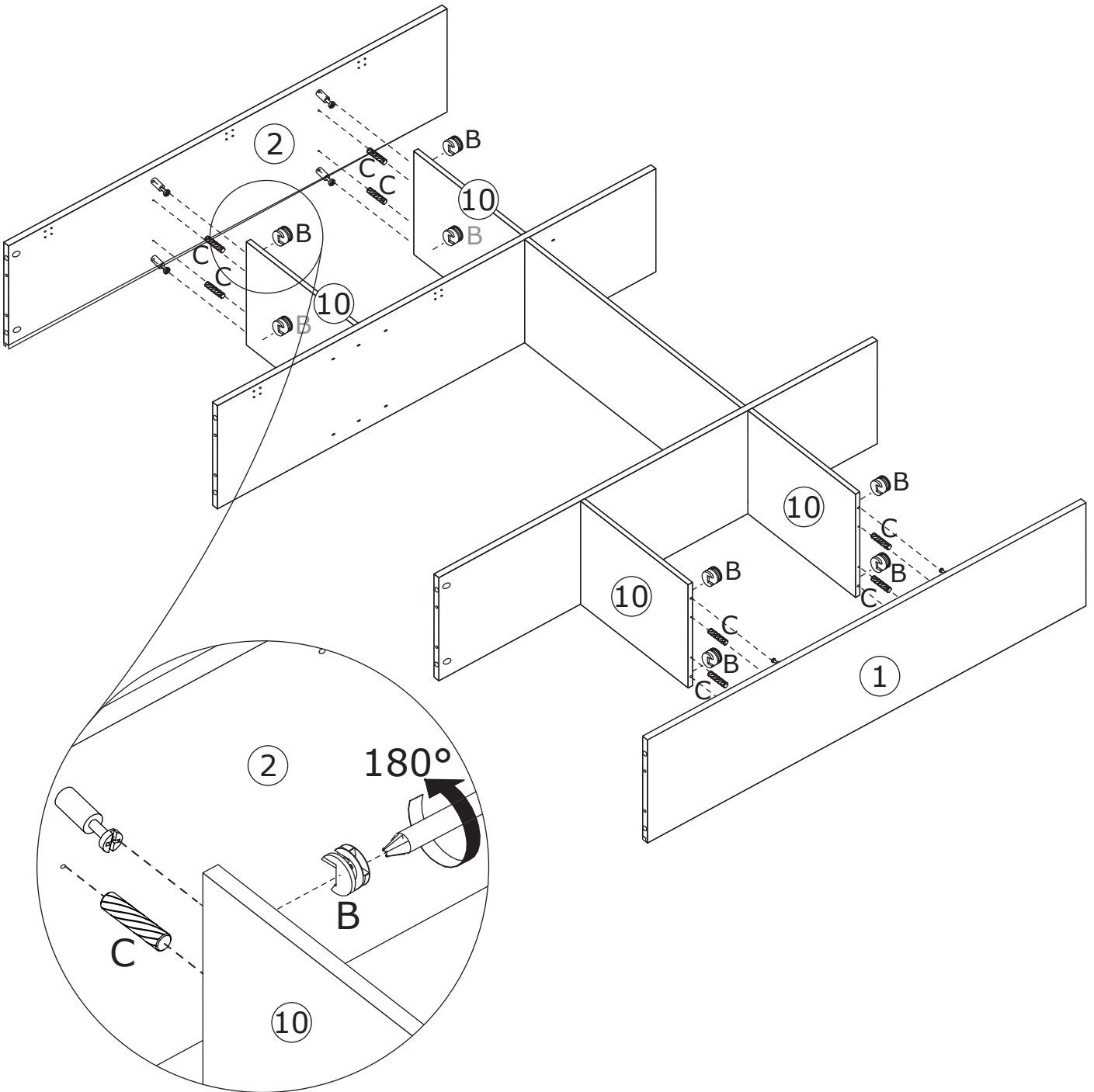
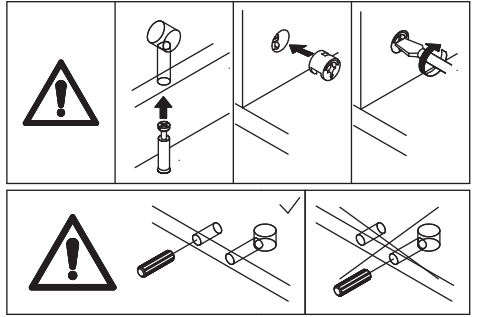
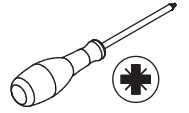
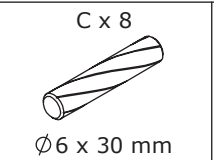
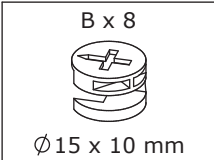

10

A x 8
Ø6 x 35 mm

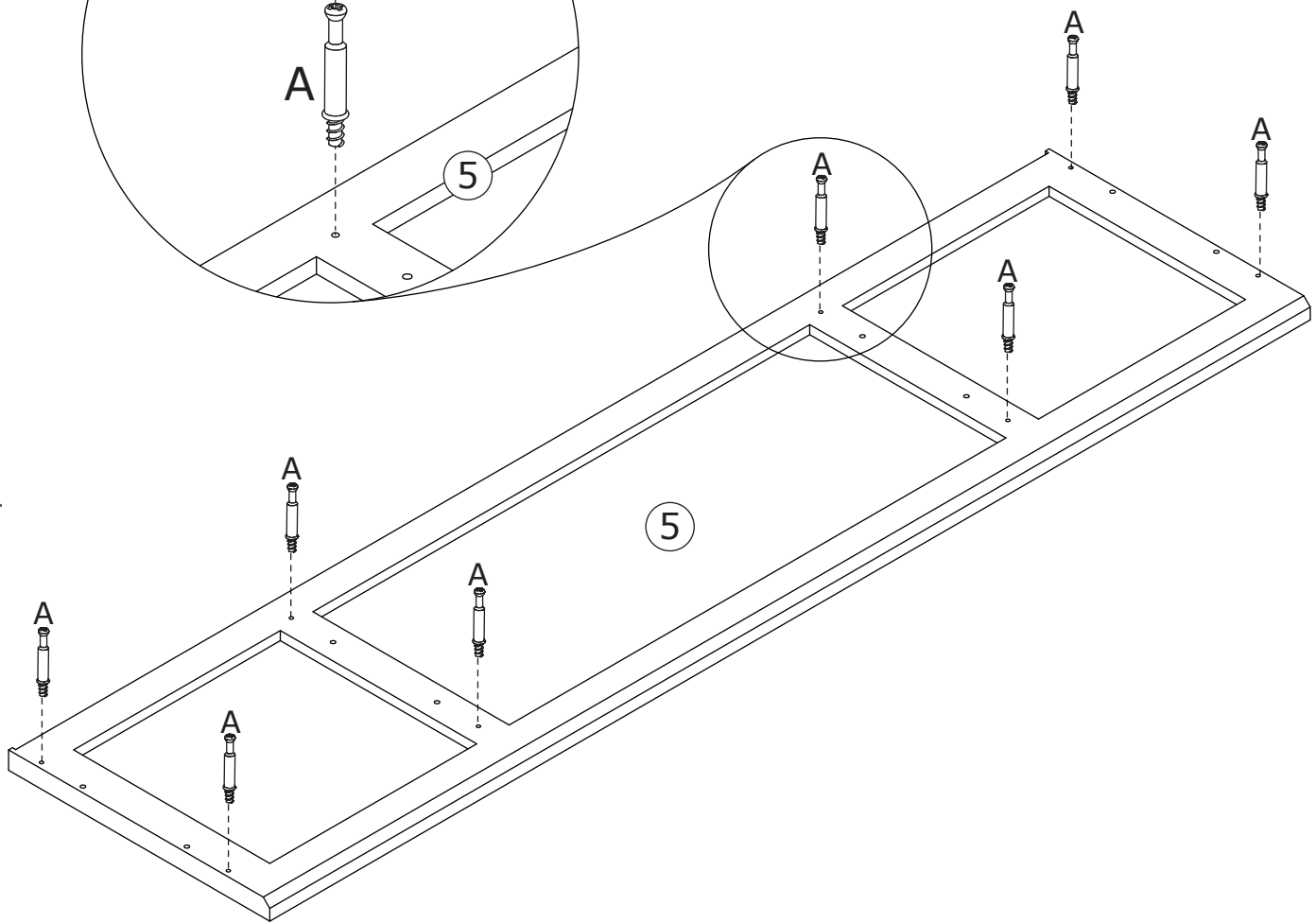
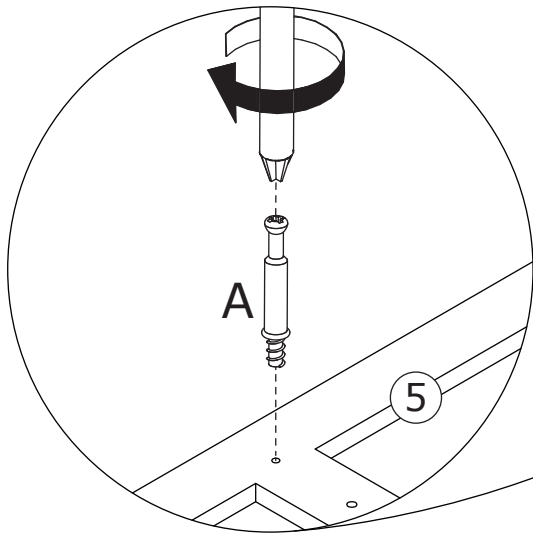
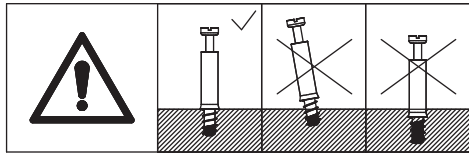
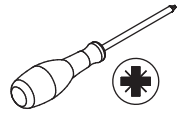

11

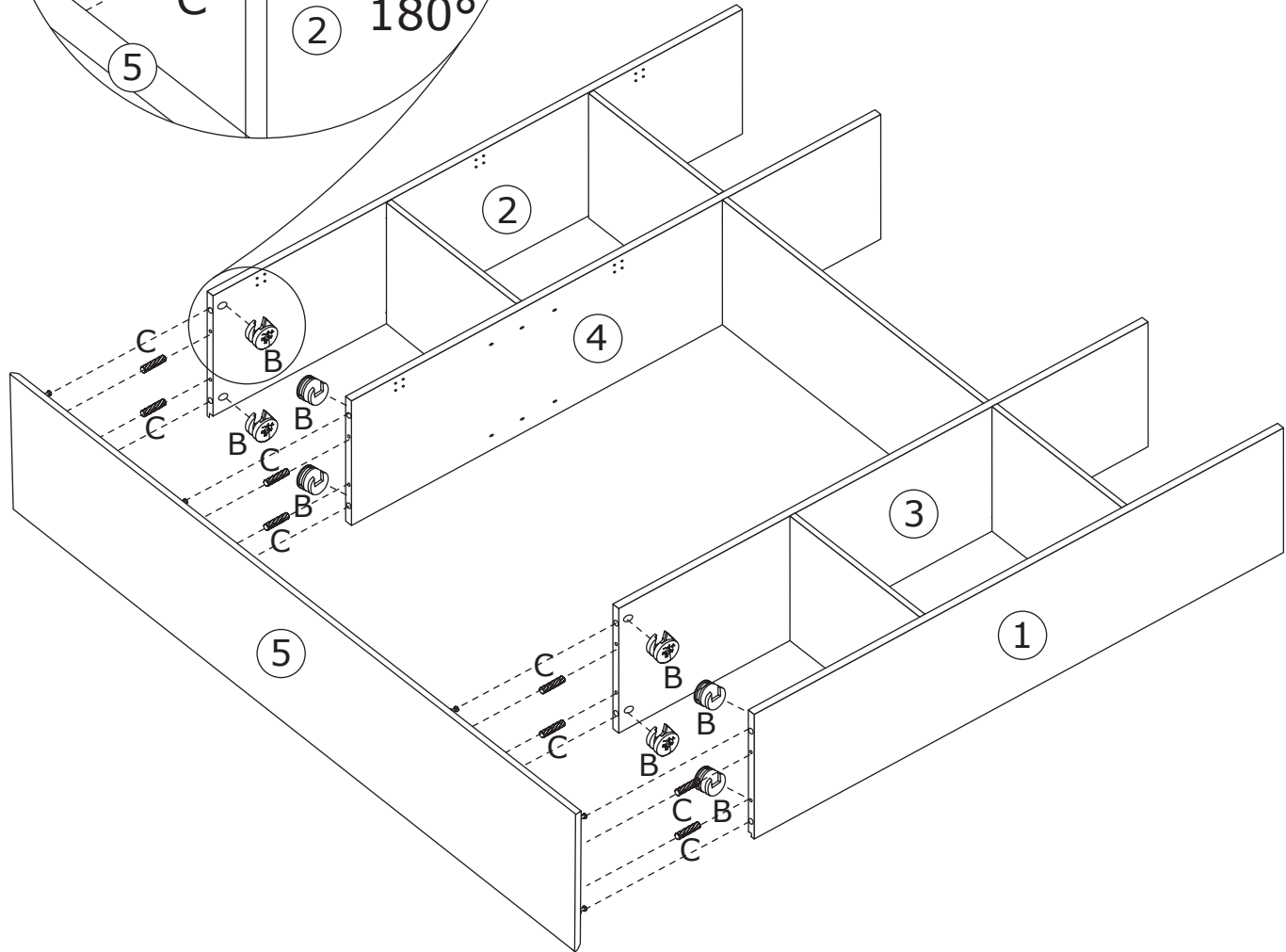
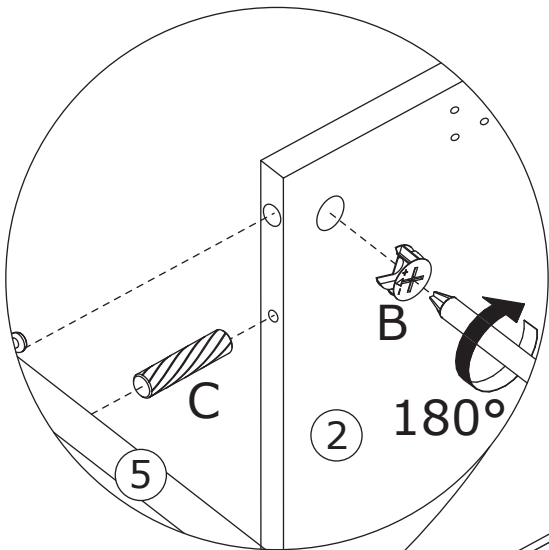
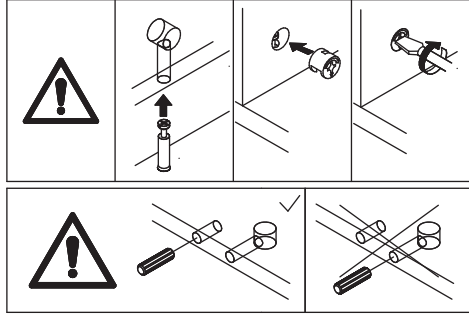
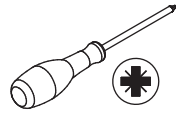
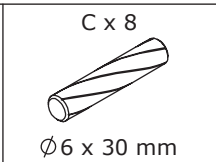
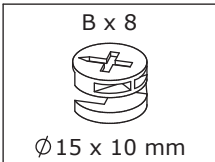

Knock wooden dowel(C)into plate 1,2, 3 and 4 at first,then attach plate 5 to.Add cam lock(B)into plate 1,3,4,2 and turn clockwise to tighten as shown.

Frapper d'abord la cheville en bois (C) dans les plaques 1, 2, 3 et 4, puis fixer la plaque 5. Ajouter le verrou à came (B) dans les plaques 1, 3, 4 et 2 et tourner dans le sens des aiguilles d'une montre pour serrer, comme indiqué.

12

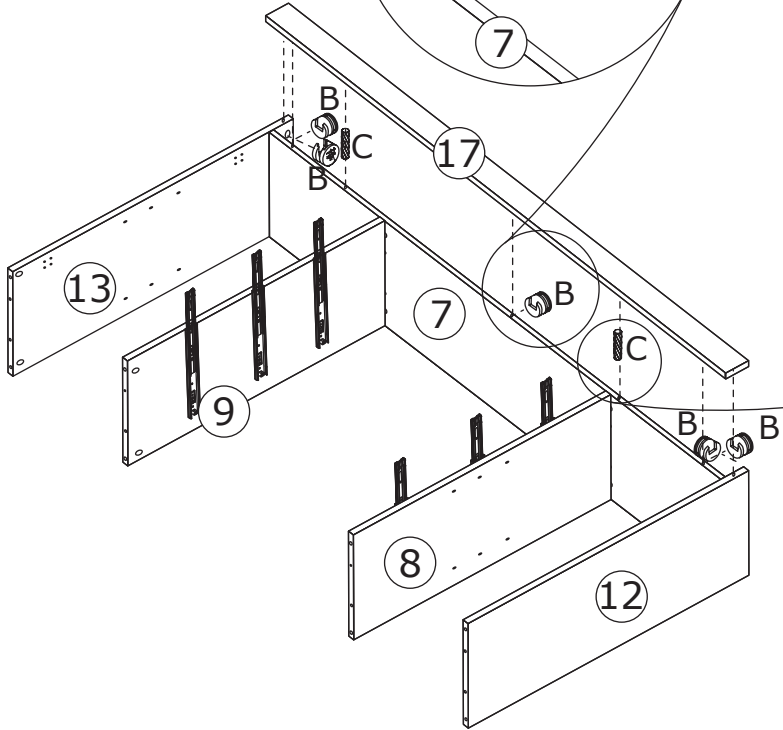
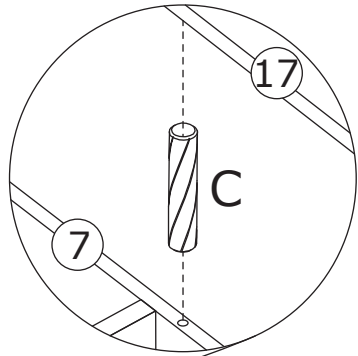
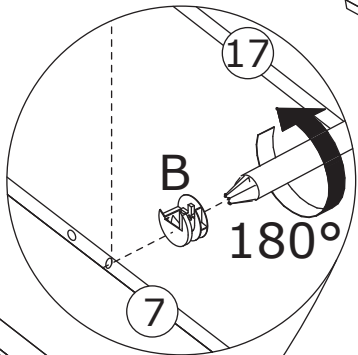
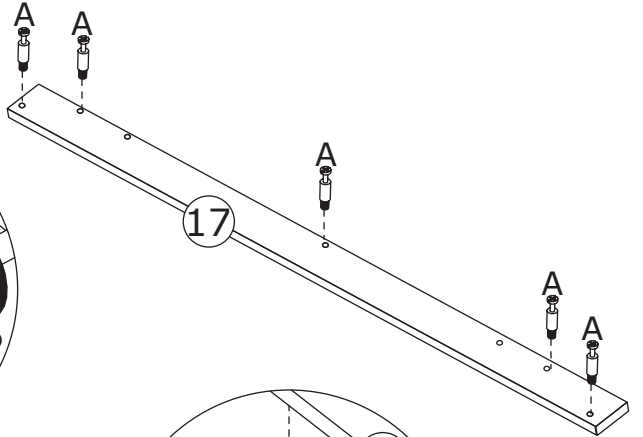
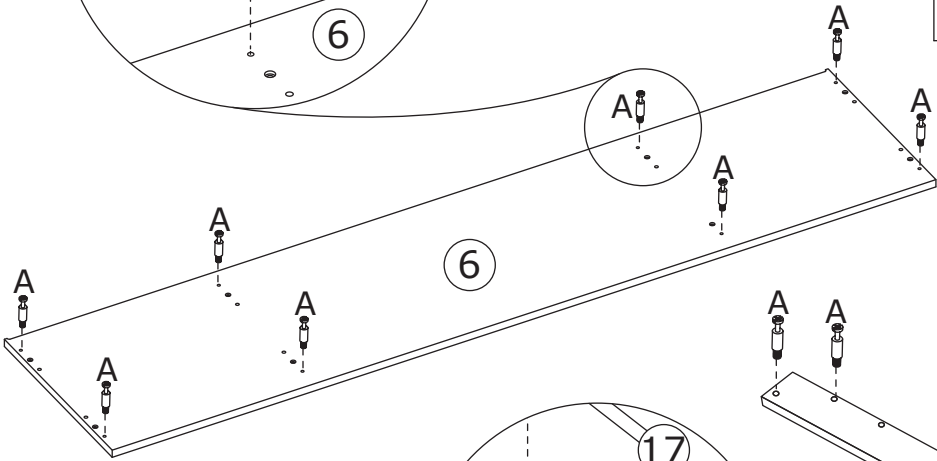
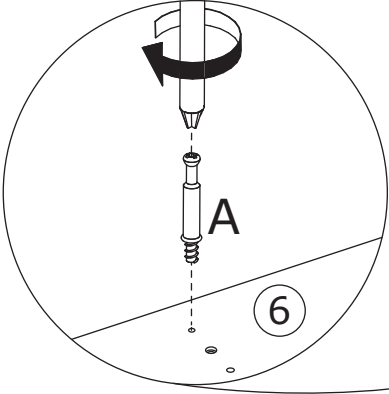
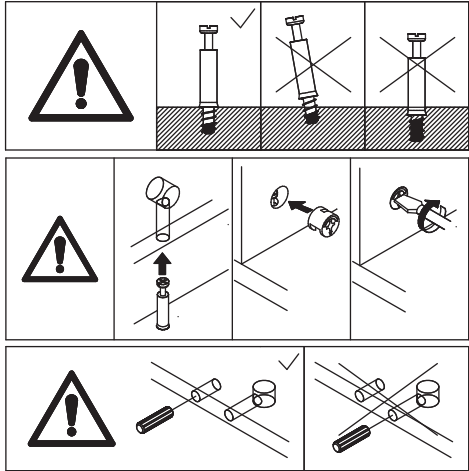
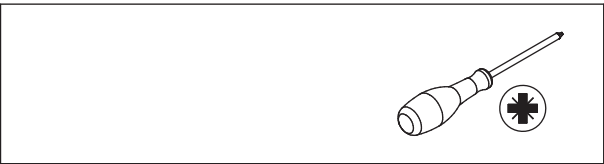
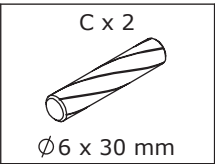
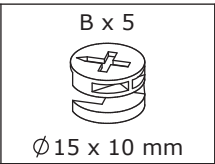
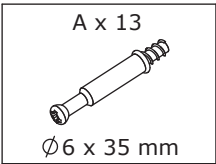

13

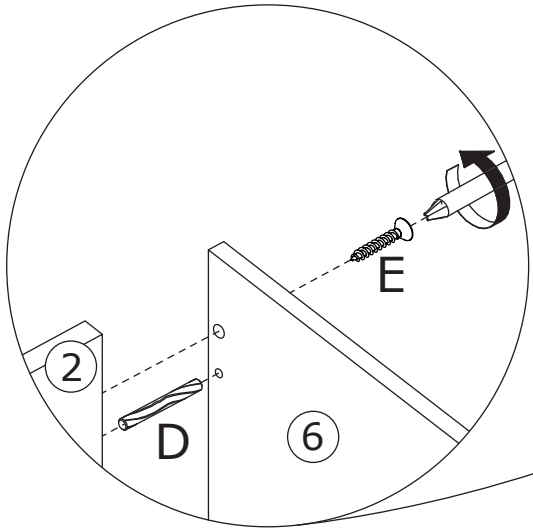
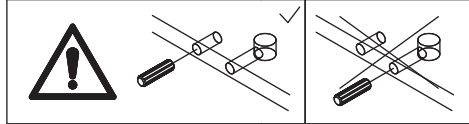
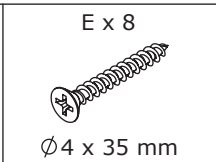
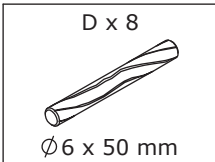

Knock **LONG** wooden dowel(D) into plate 1, 3, 4 and 2 at first, then attach plate 6 to and fix with screw(E) as shown.

Frappez d'abord une **LONGUE** cheville en bois (D) dans les plaques 1, 3, 4 et 2, puis fixez la plaque 6 et fixez-la à l'aide de la vis (E) comme indiqué.

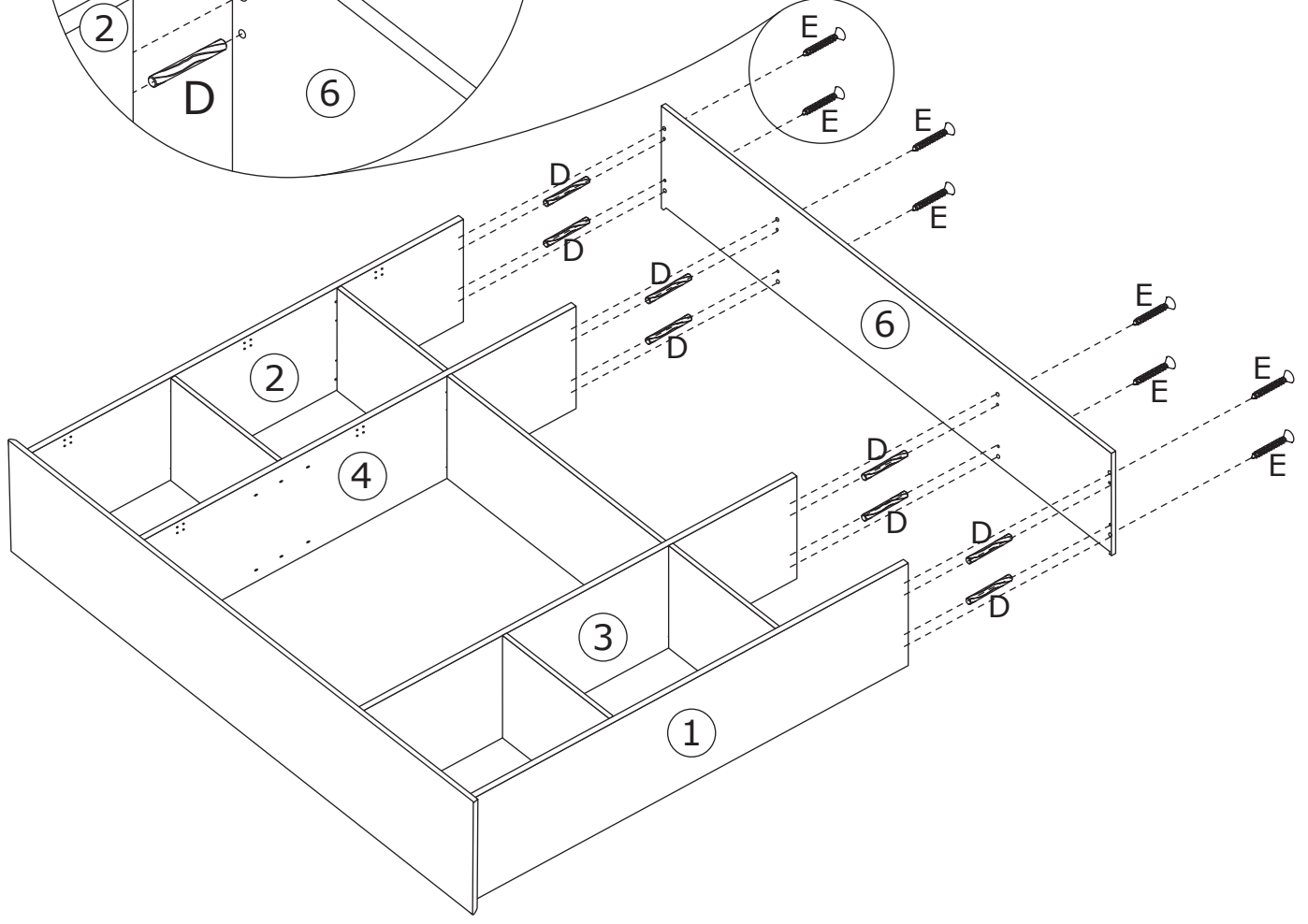

14

B x 8
Ø15 x 10 mm

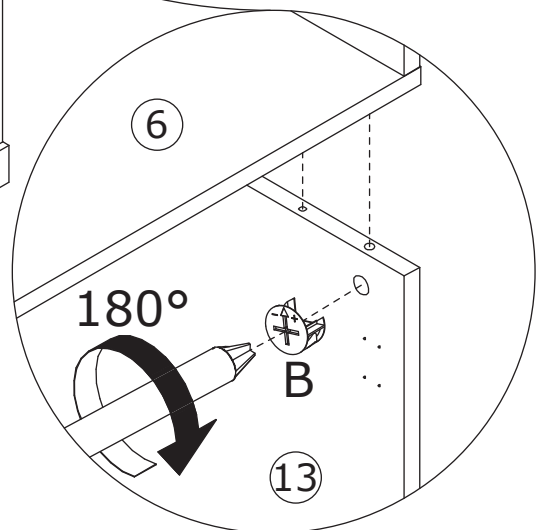
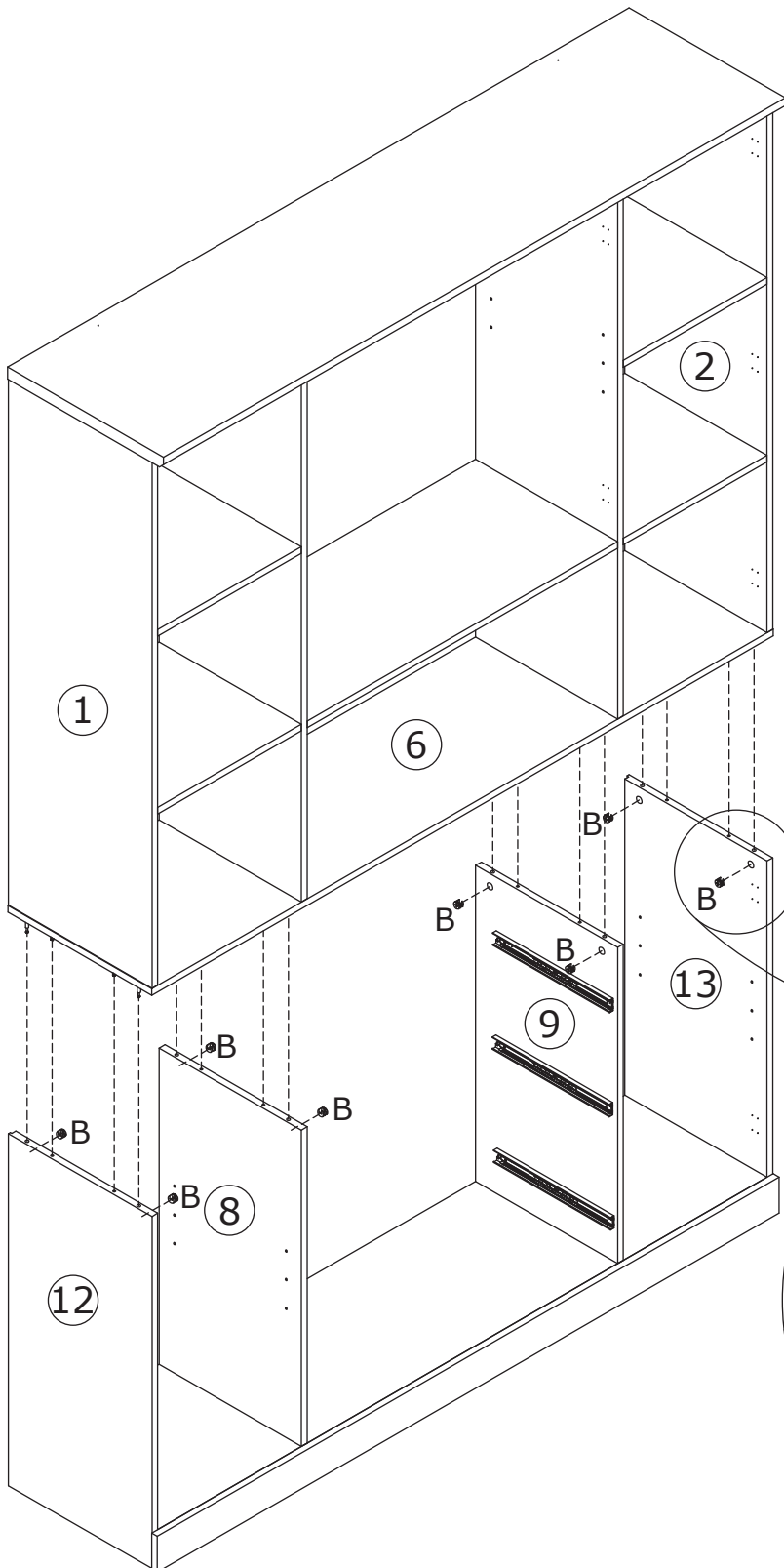
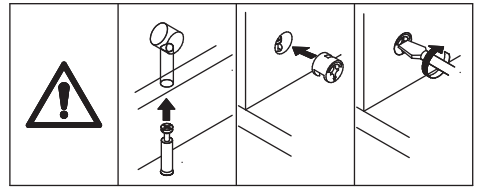
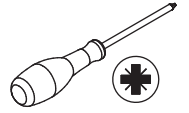

15

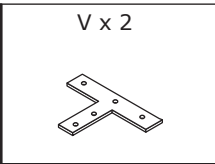
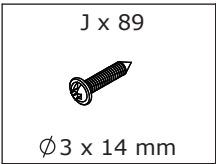

Fix back plate 16,20,21,30,31 and 32 to the cabinet with screw(J) as shown.
Fixer la plaque arrière 16,20,21,30,31 et 32 à l'armoire à l'aide de la vis (J) comme indiqué.

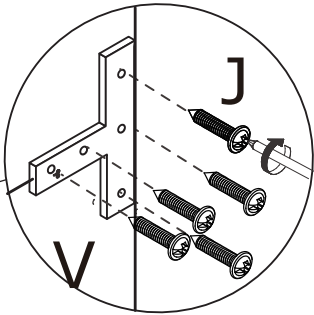
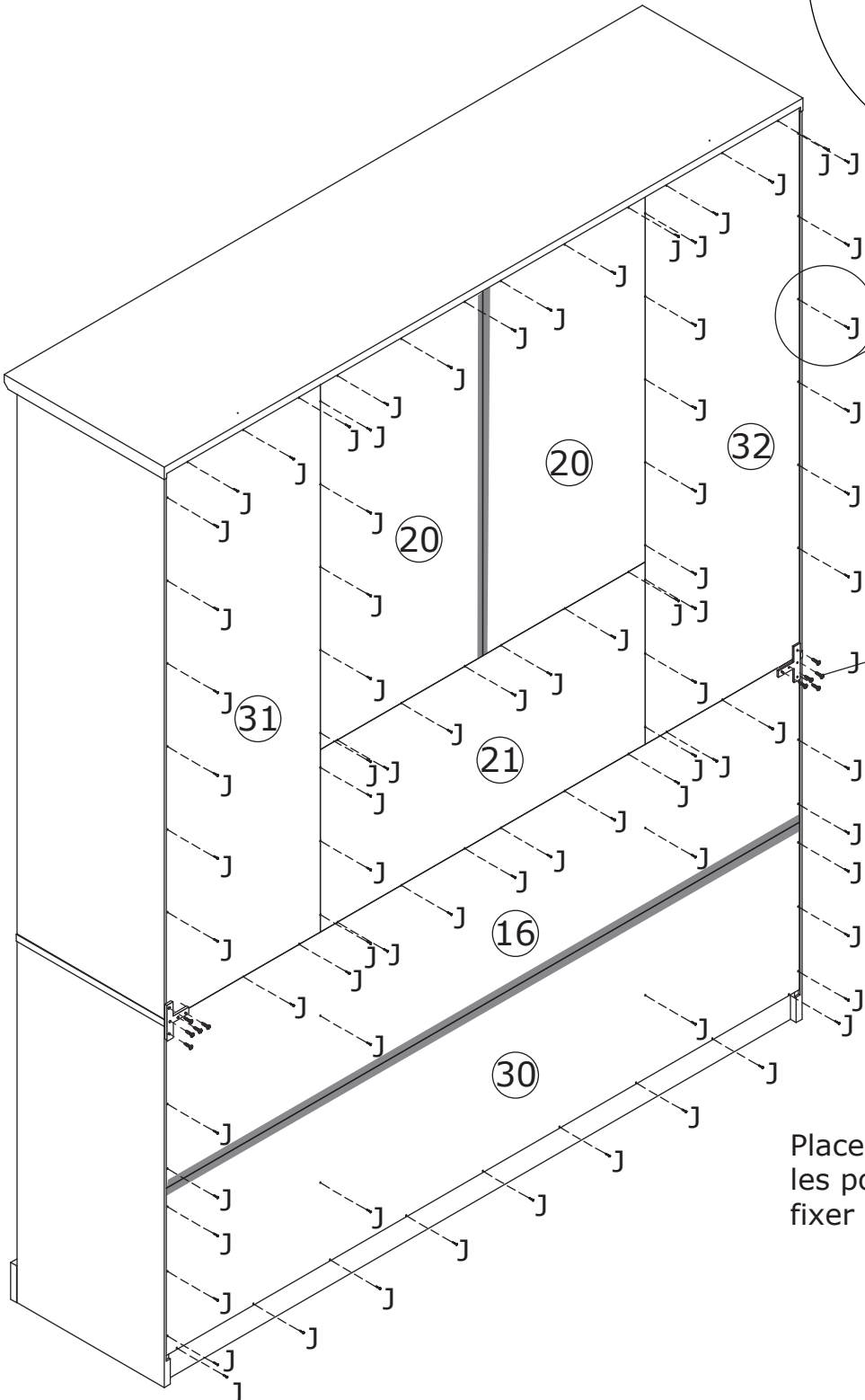
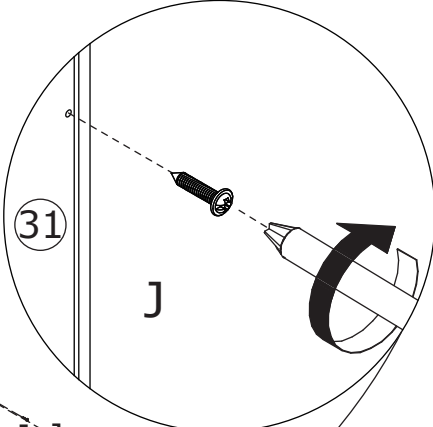

Place the hardware (V) in the position shown and fix them with screw (J)

Placer le matériel (V) dans les positions indiquées et le fixer avec les vis (J).

16

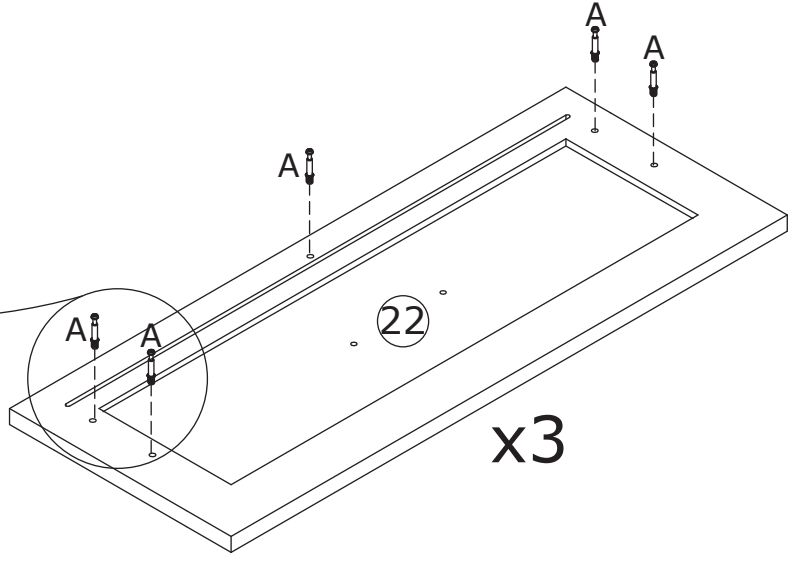
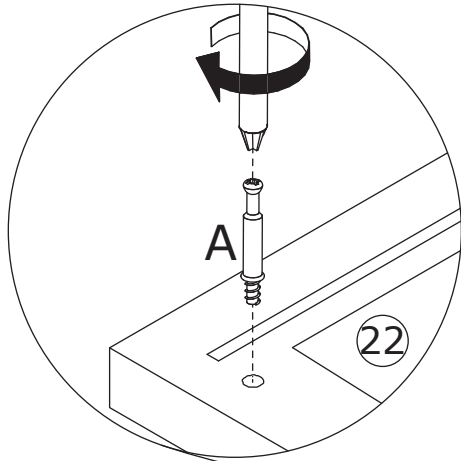
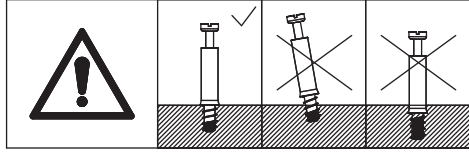
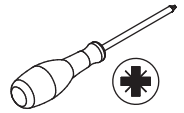
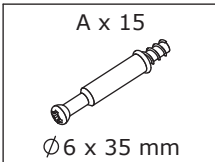

17

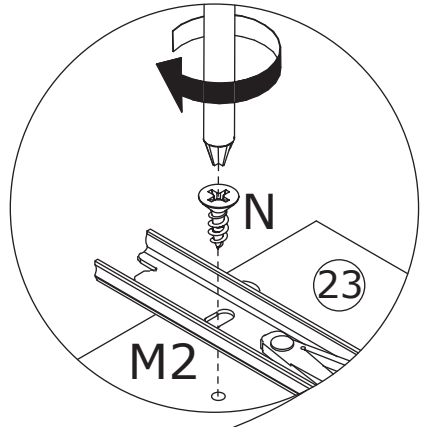
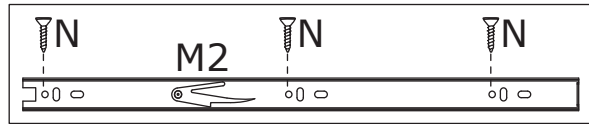
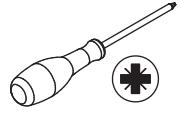
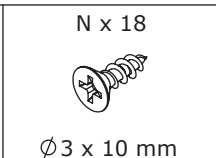
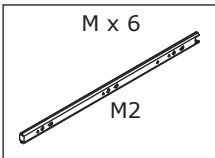

Fix runner(M2) to plate 23 and 24 with screw(N) as shown.

Fixer la glissière (M2) aux plaques 23 et 24 à l'aide de la vis (N) comme indiqué.

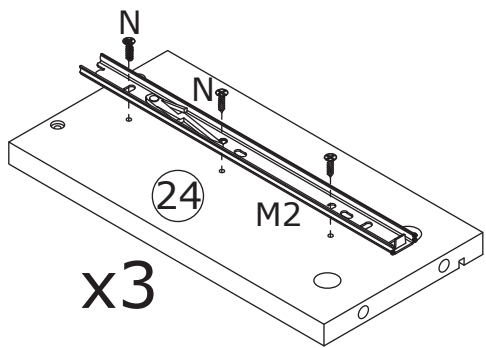
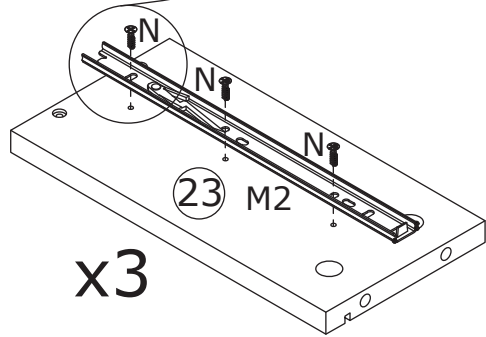

18

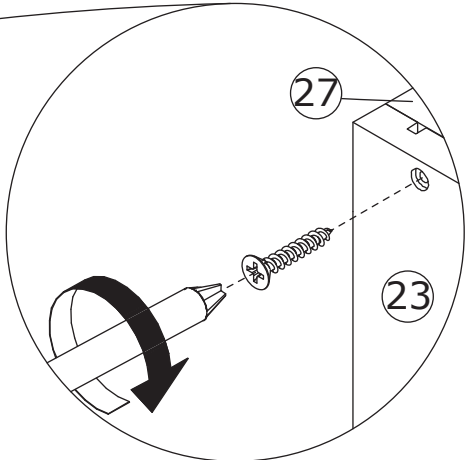
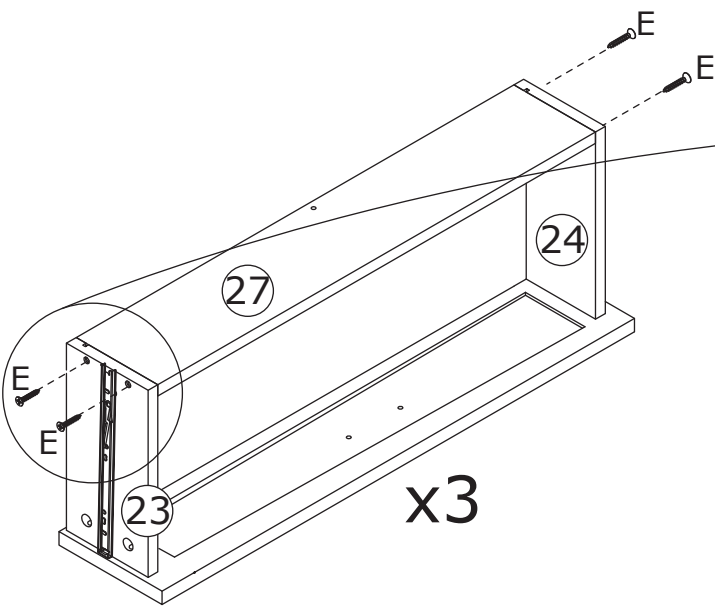
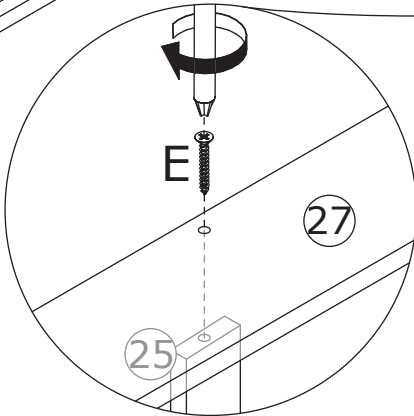
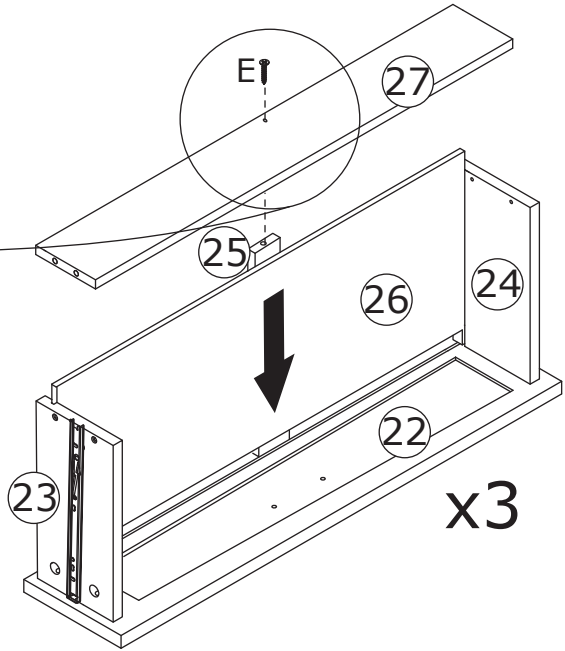
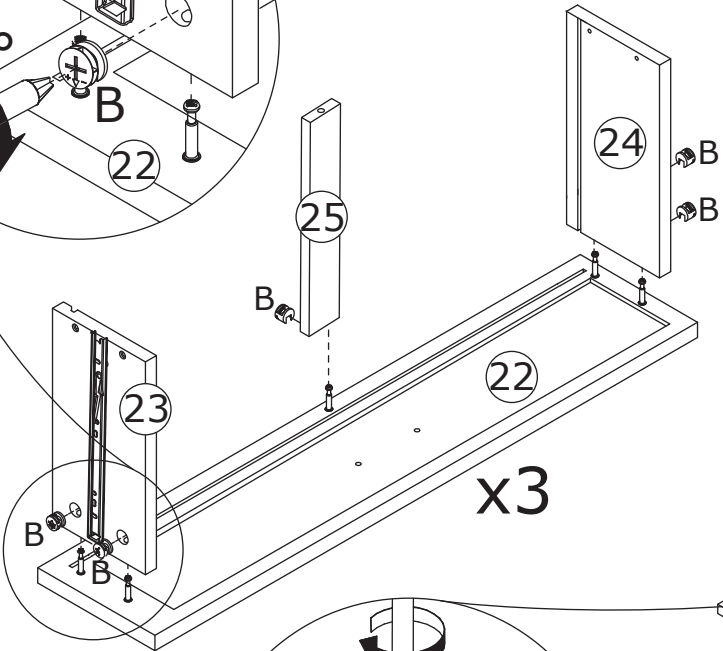
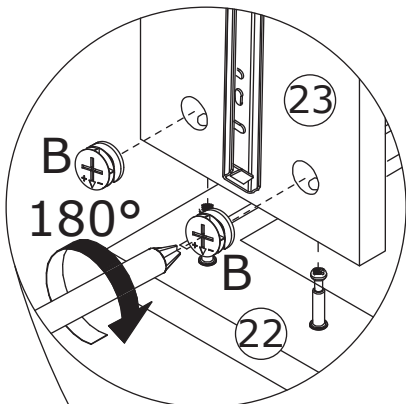
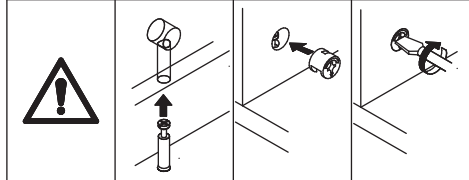
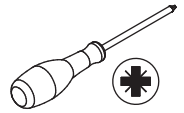
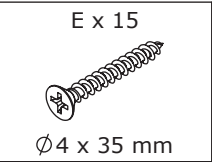
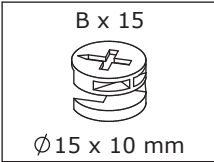

19

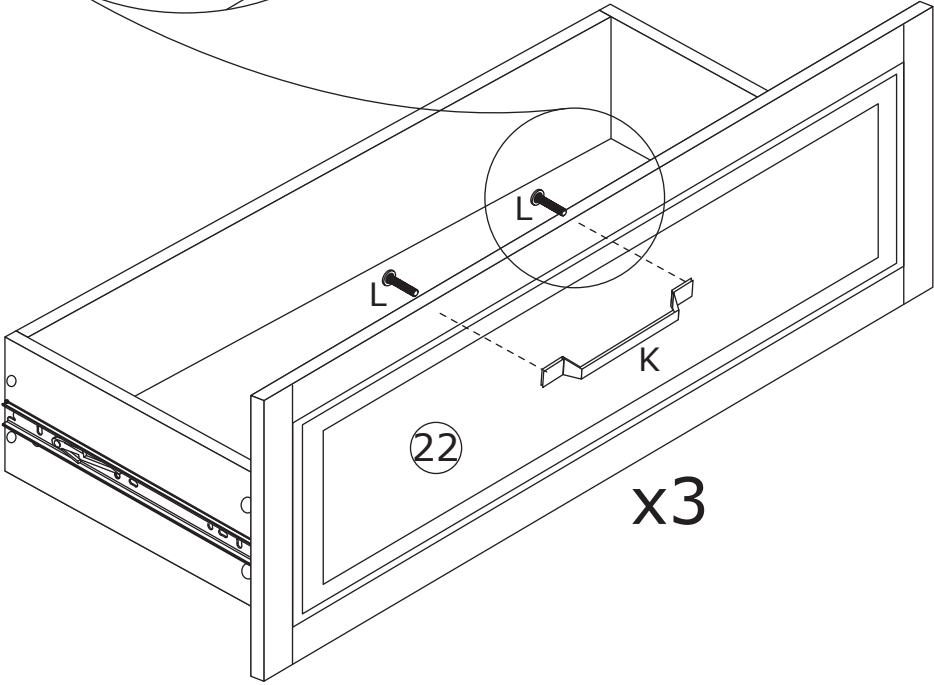
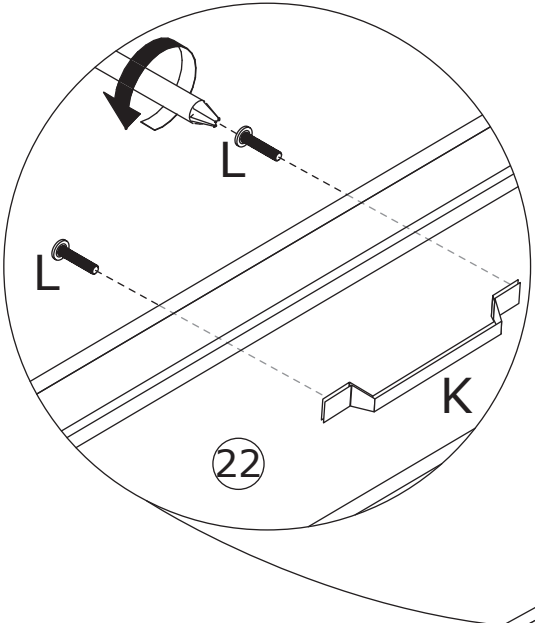
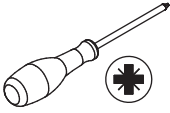
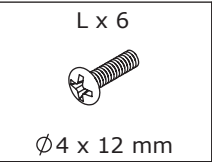
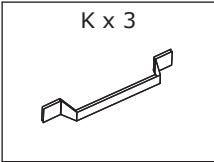

20

Align rails, slide the drawers in.

Aligner les rails, glisser les tiroirs.

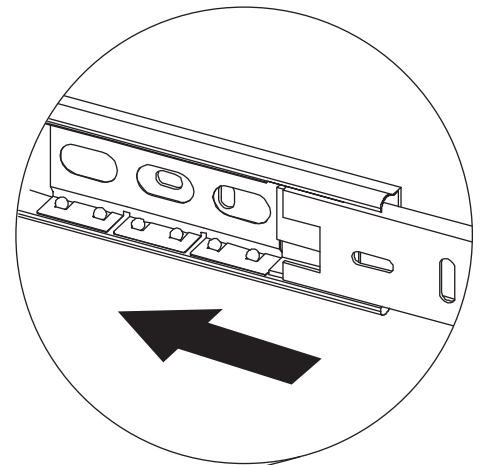
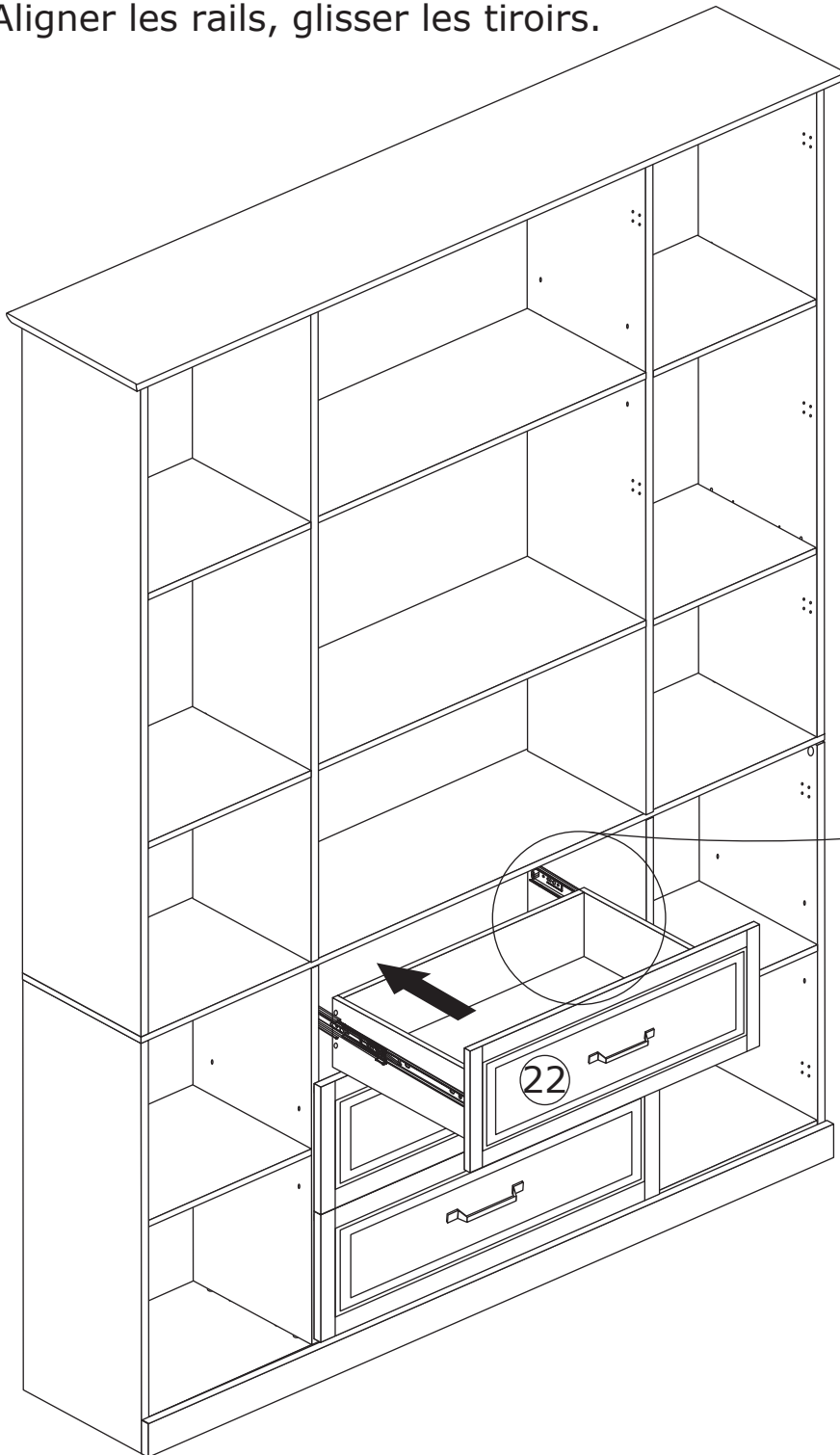

21

T x 12

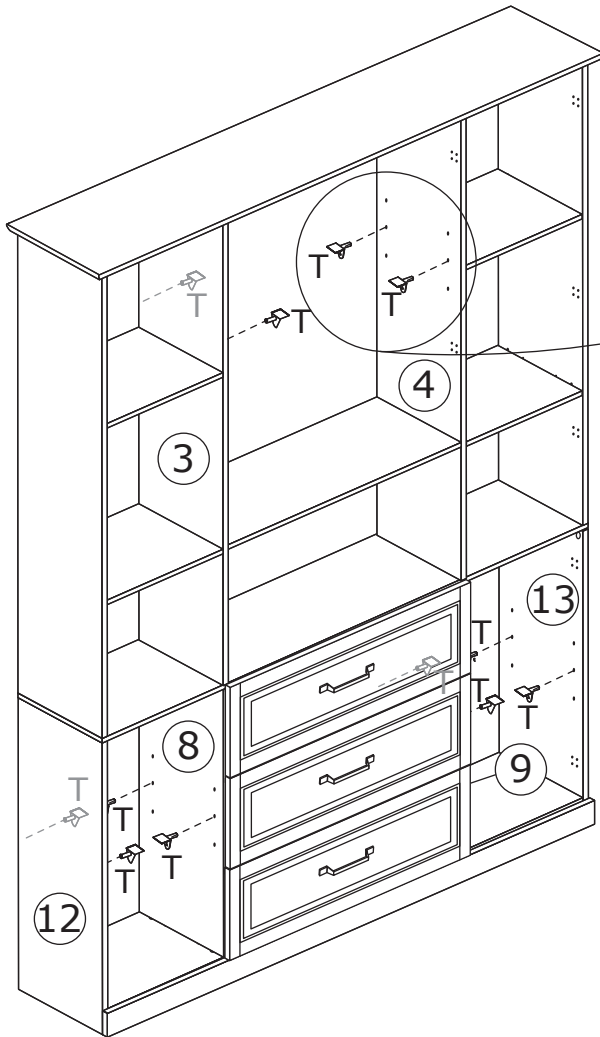
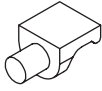

Insert part(T) into plate 3,4,12,8,9 and 13,then place shelf plate 14 and 34in as shown.

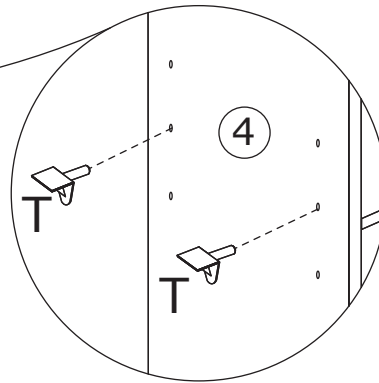

Insérer la pièce (T) dans les plaques 3, 4, 12, 8, 9 et 13, puis placer les étagères 14 et 34in comme indiqué.

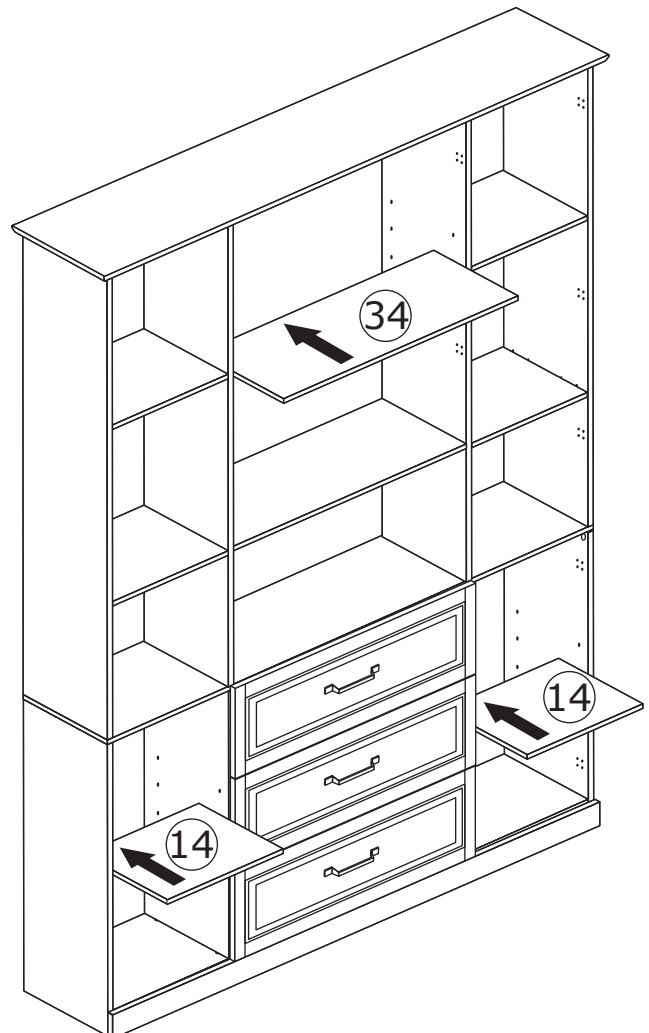



Pay attention to the difference between the middle parts of the two types of door hinges.

- The curved door hinges(P) are used on the outermost door plates.
- And the full coverage door hinges(Q) are used on the door panel in the middle of the cabinet.



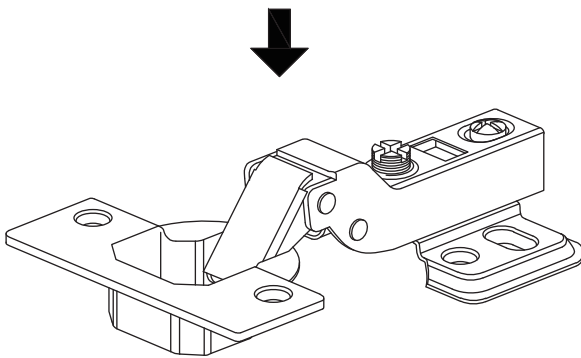
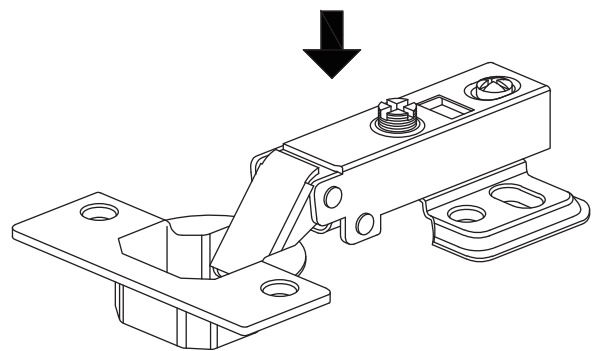

Notez la différence entre les deux types de charnières de porte au milieu.

- Charnières de porte incurvées (p) pour les panneaux de porte les plus extérieurs.
- La charnière de porte entièrement couverte (q) est utilisée sur le panneau de porte au milieu de l'armoire.

**S****U**

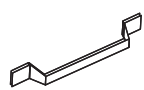
23

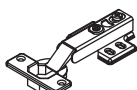
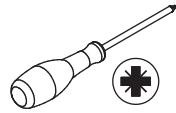
<p>G x 20</p>  <p>Ø4 x 12 mm</p>	<p>K x 4</p> 	<p>L x 8</p>  <p>Ø4 x 12 mm</p>	<p>U x 10</p> 	
-------------------------------------------------------------------------------------------------------------------	------------------------------------------------------------------------------------------------	------------------------------------------------------------------------------------------------------------------	--------------------------------------------------------------------------------------------------	-------------------------------------------------------------------------------------

Fix hinge(U) to plate 18, 28 and 29 with screw(G)as shown.

Fixer la charnière (U) aux plaques 18, 28 et 29 à l'aide de la vis (G) comme indiqué.

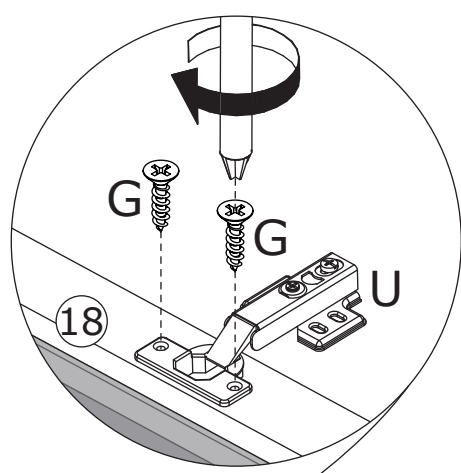
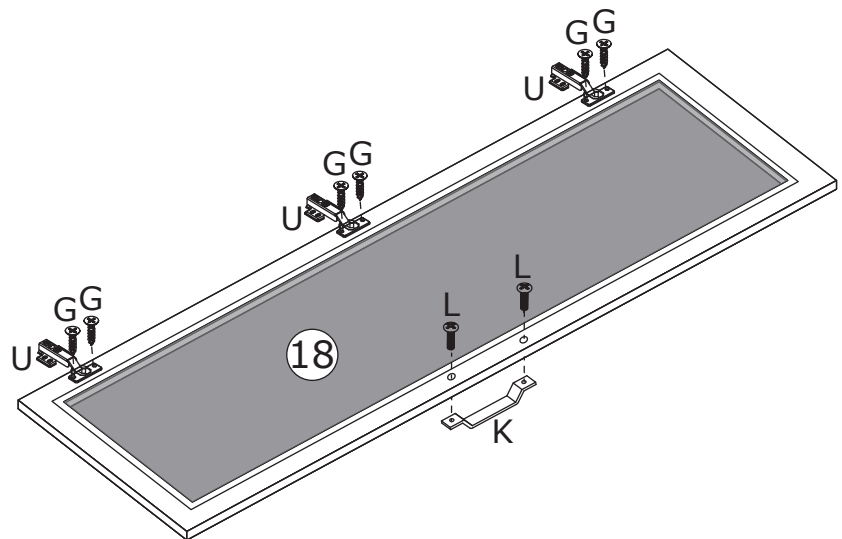
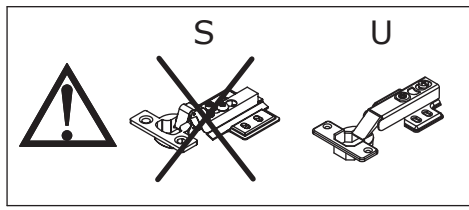

Fix handle(K) to door plate with screw(L) as shown.

Fixer la poignée (K) à la plaque de porte à l'aide de la vis (L) comme indiqué.

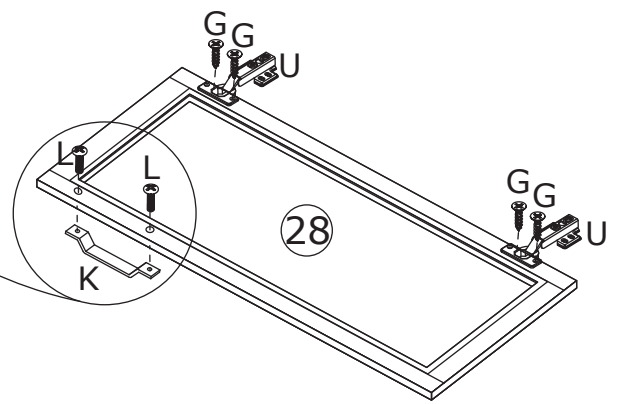
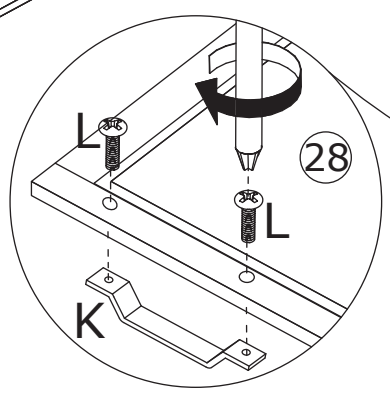
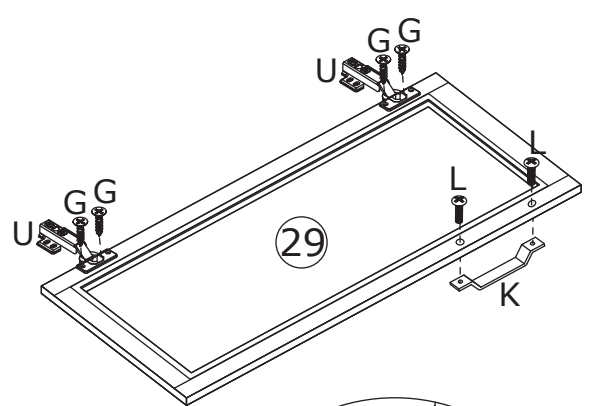
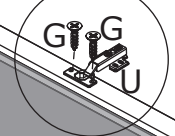
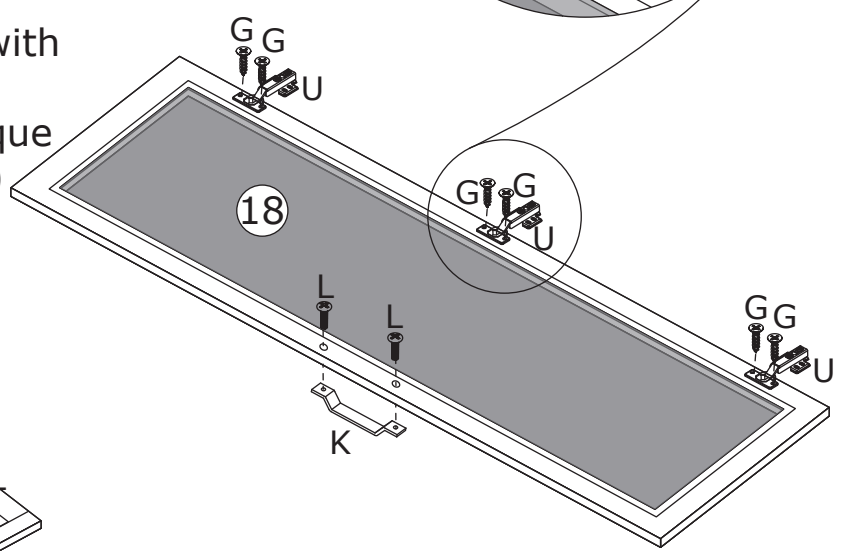

24

G x 40



Ø4 x 12 mm

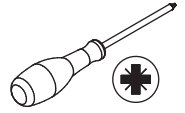

S



U

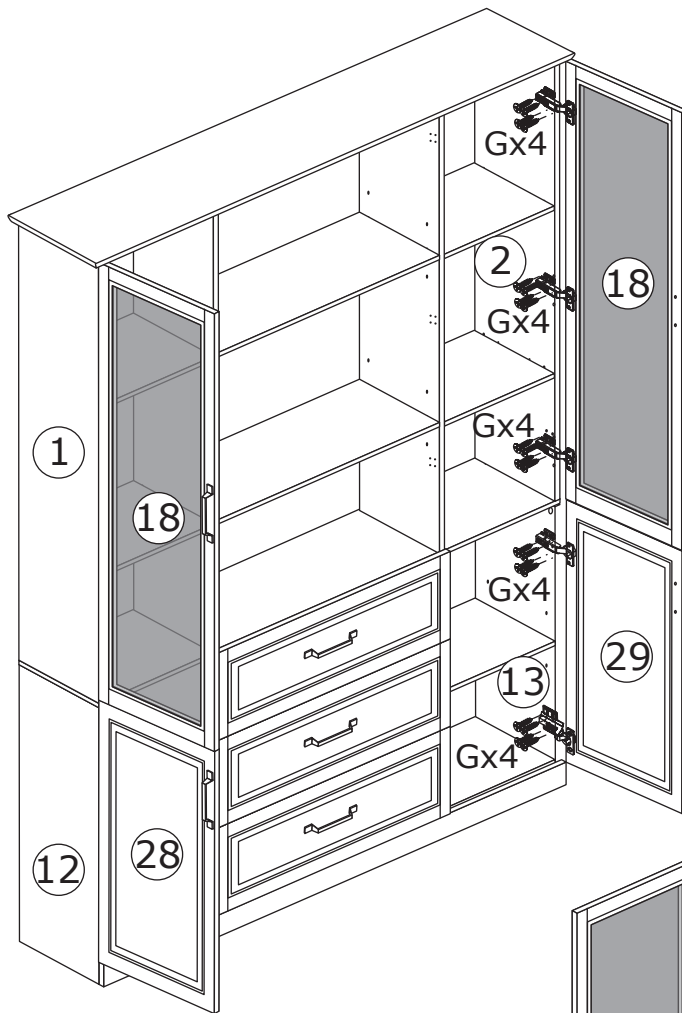
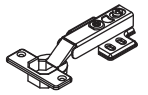

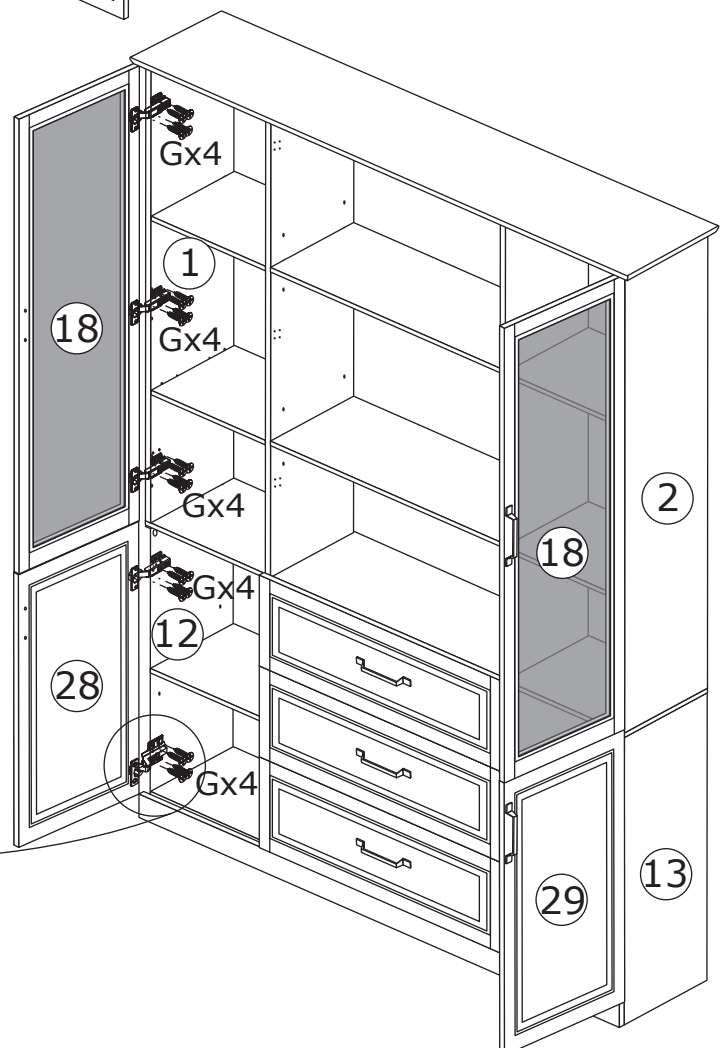
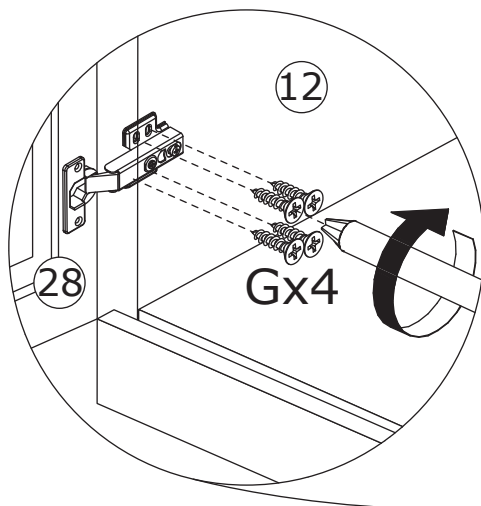

Attach door plate 18 to upper cabinet; door plate 28 and 29 to lower cabinet by fixing hinge with screw (G) as shown.

Fixer la plaque de porte 18 à l'armoire supérieure ; les plaques de porte 28 et 29 à l'armoire inférieure en fixant la charnière à l'aide de la vis (G) indiquée.

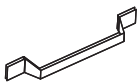

25

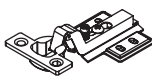
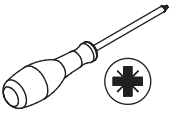
<p>G x 8  Ø4 x 12 mm</p>	<p>K x 2 </p>	<p>L x 8  Ø4 x 12 mm</p>	<p>S x 4 </p>	<p></p>
-------------------------------------------------------------------------------------------------------------------	----------------------------------------------------------------------------------------------------	-------------------------------------------------------------------------------------------------------------------	-----------------------------------------------------------------------------------------------------	--------------------------------------------------------------------------------------------

Fix hinge(S) to plate 19 with screw(G) as shown.

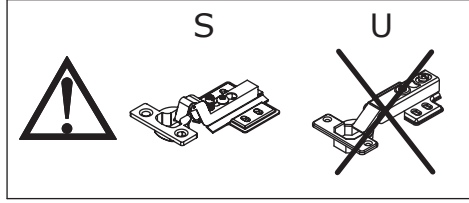

Fixer la charnière (S) à la plaque 19 à l'aide de la vis (G) comme indiqué.

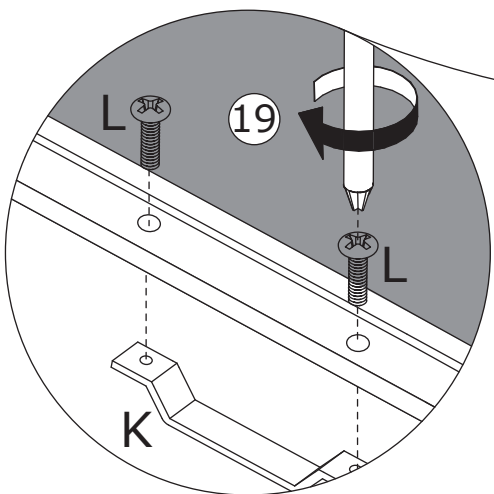
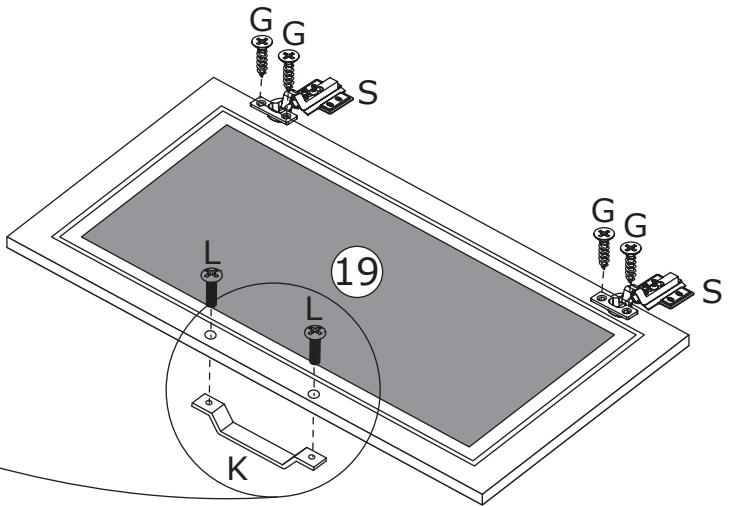
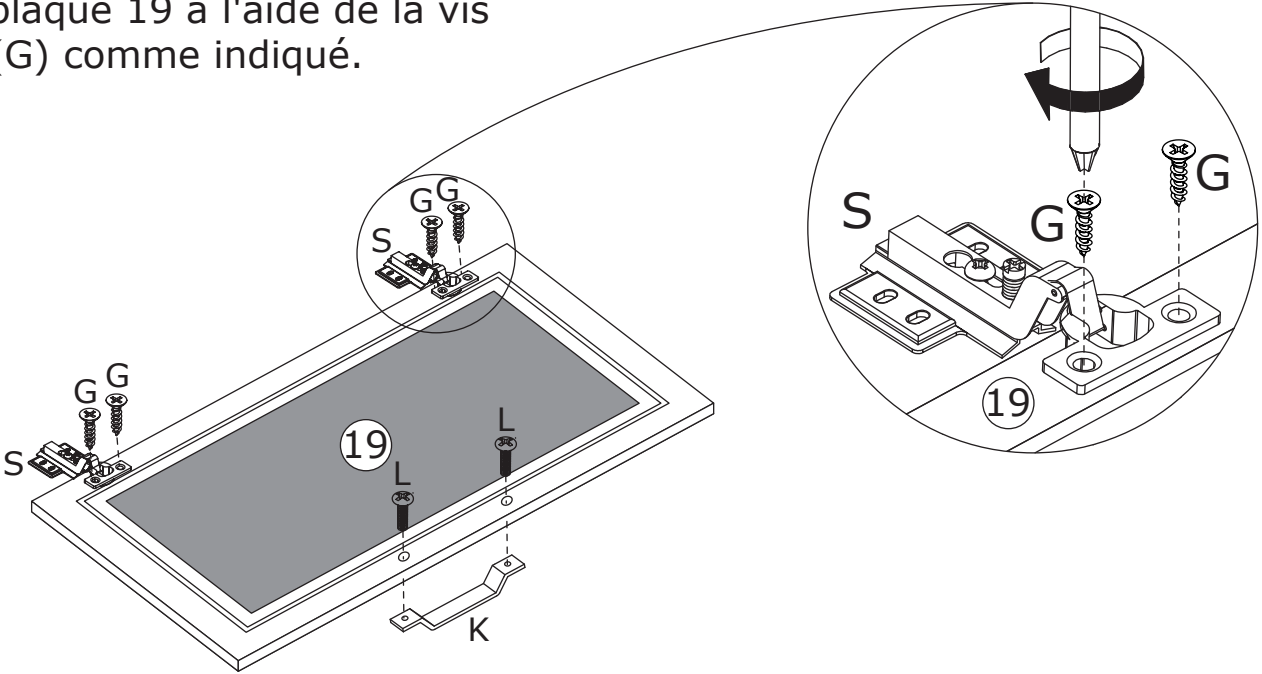

Fix handle(K) to door plate with screw(L) as shown.

Fixer la poignée (K) à la plaque de porte à l'aide de la vis (L) comme indiqué.

26

G x 16



Ø4 x 12 mm

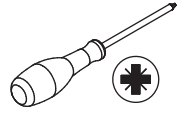

S



U

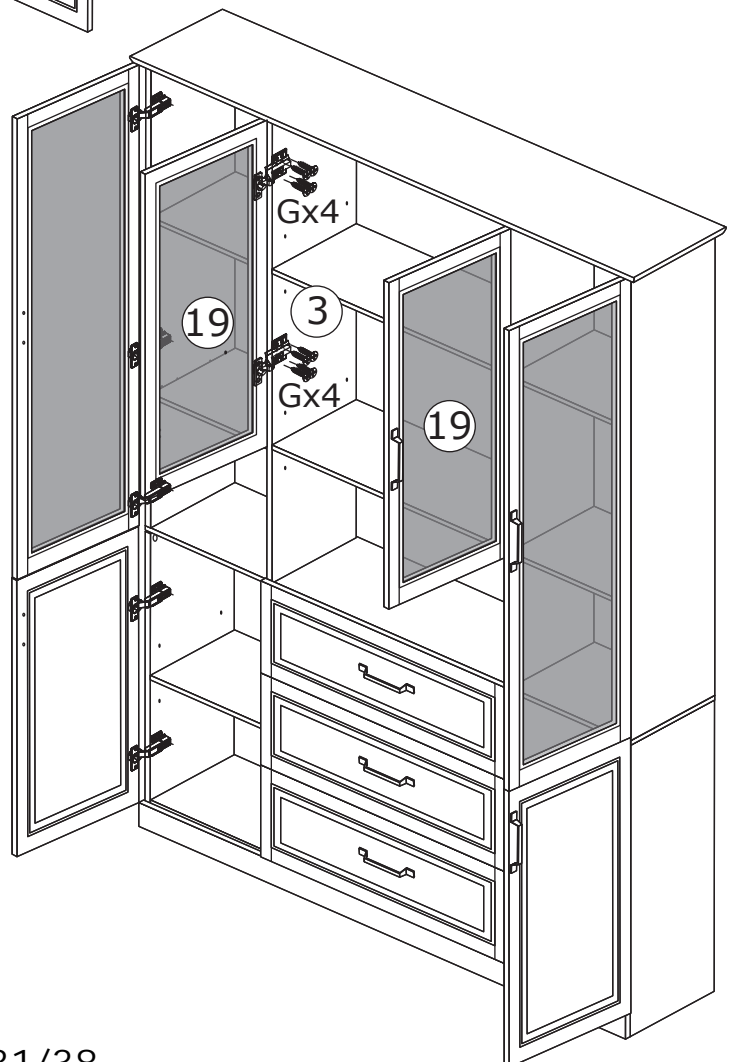
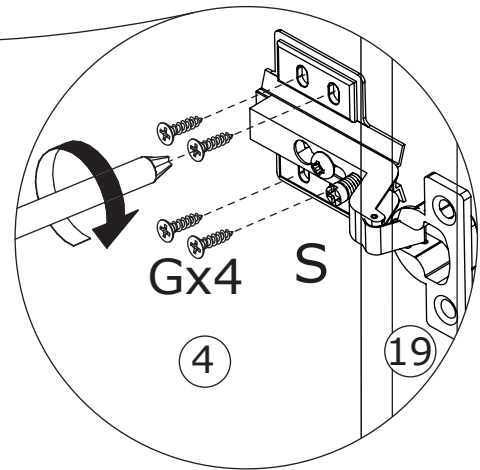
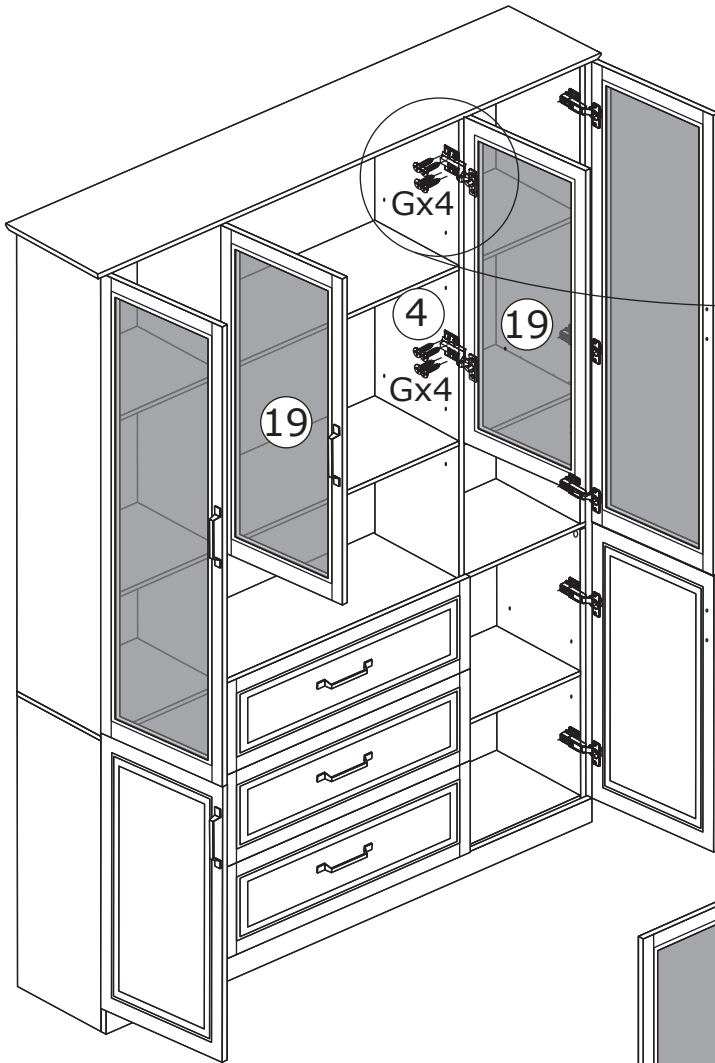
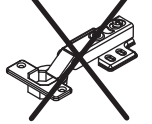

Attach door plate 19 to upper cabinet by fixing hinge with screw(G) as shown.

Fixer la plaque de porte 19 à l'armoire supérieure en fixant la charnière à l'aide de la vis (G) comme indiqué.

26

F x 2



H x 2



Ø4 x 12 mm

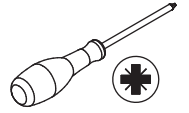

Fix part(F) to plate 5 with screw(H) as shown.

Fixer la pièce (F) à la plaque 5 à l'aide de la vis (H) comme indiqué.

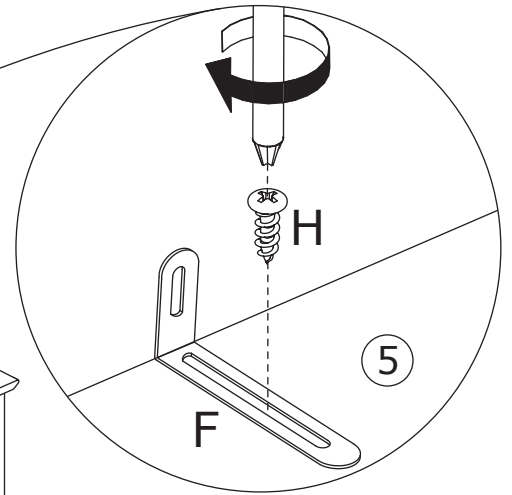
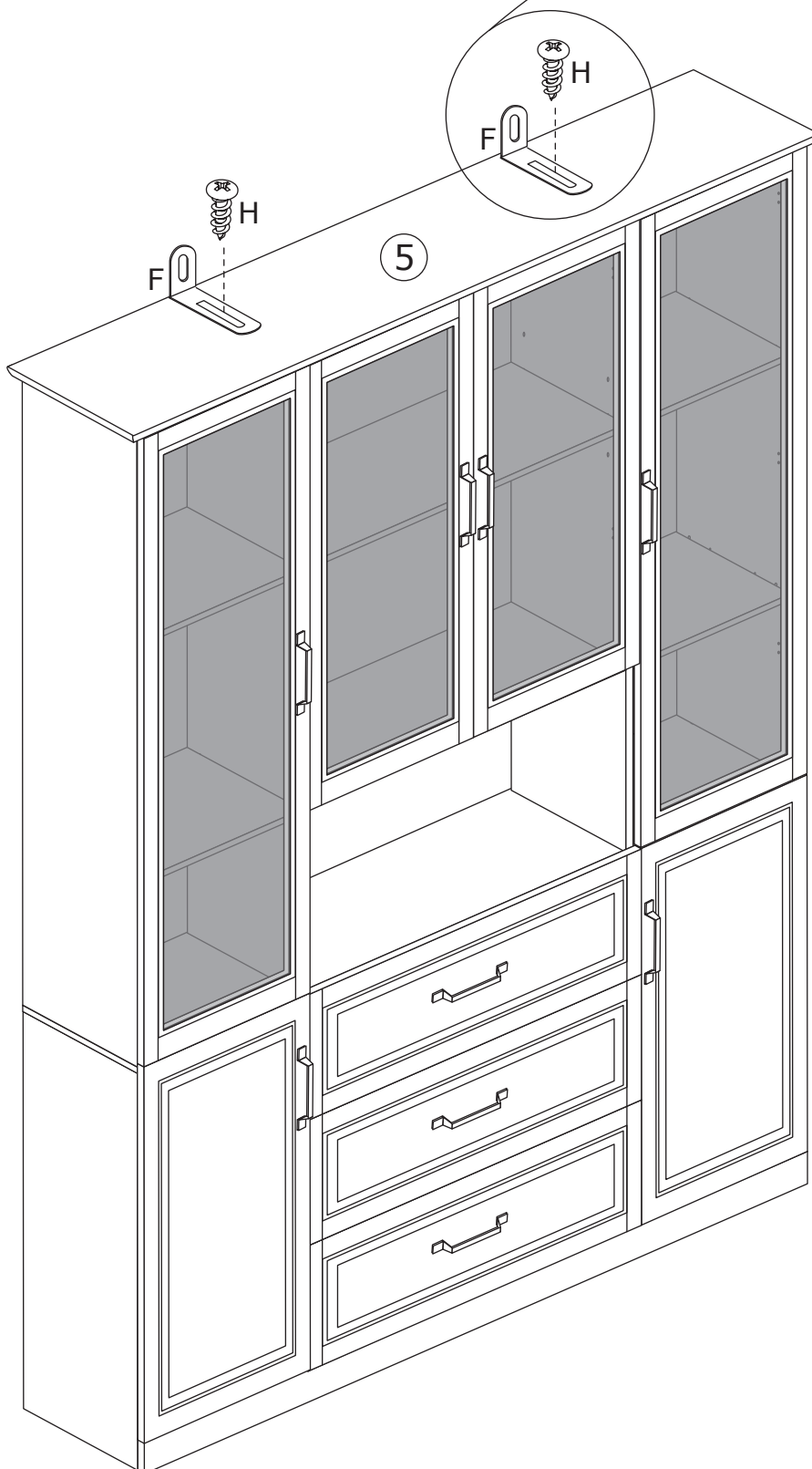

27

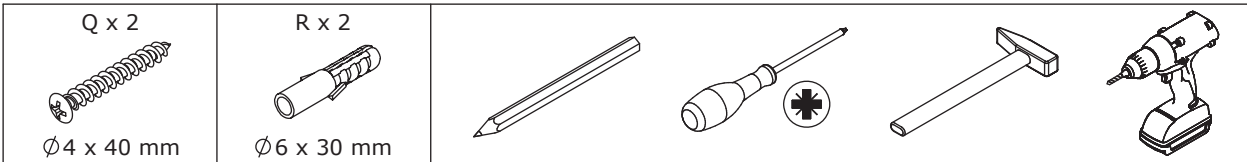

Install anti-tipping device as shown.

Installer le dispositif anti-basculement
comme indiqué.

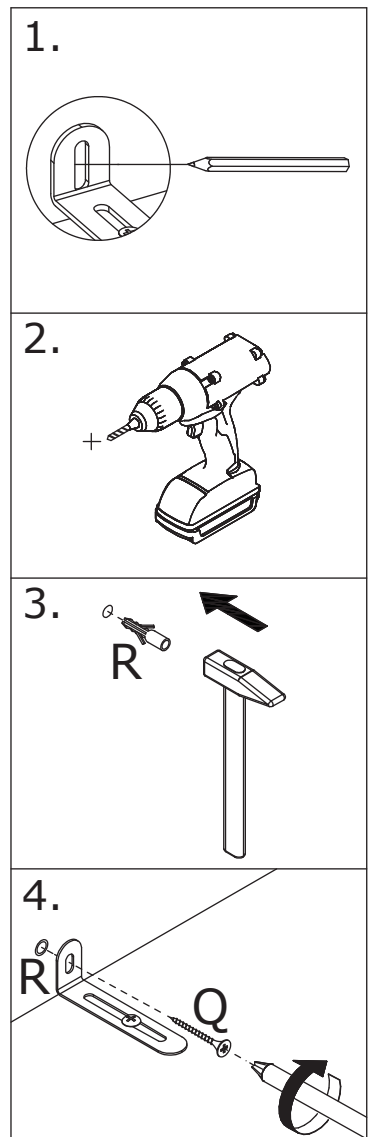
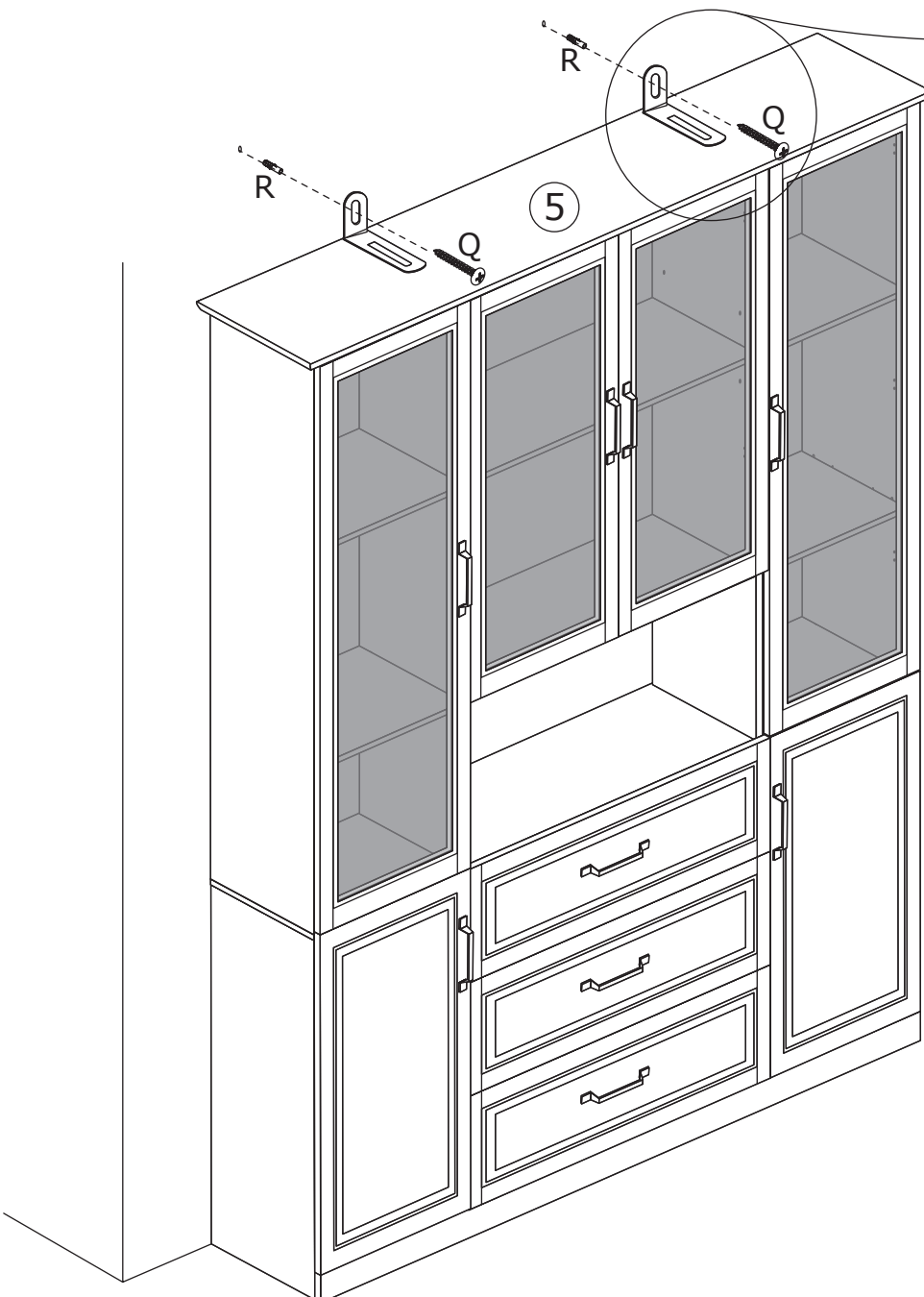
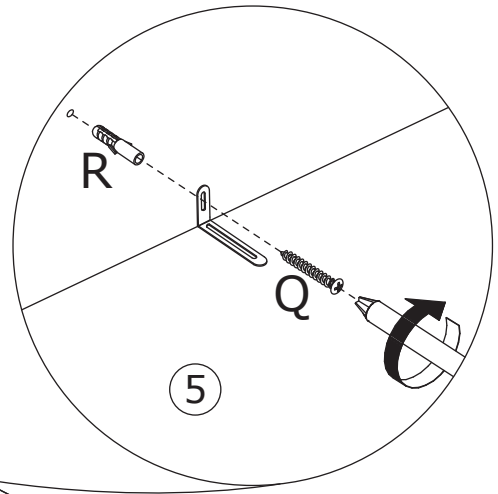

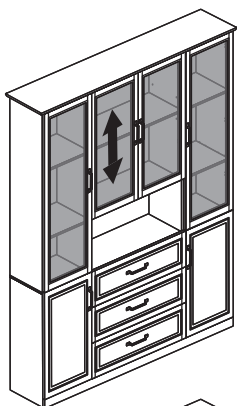
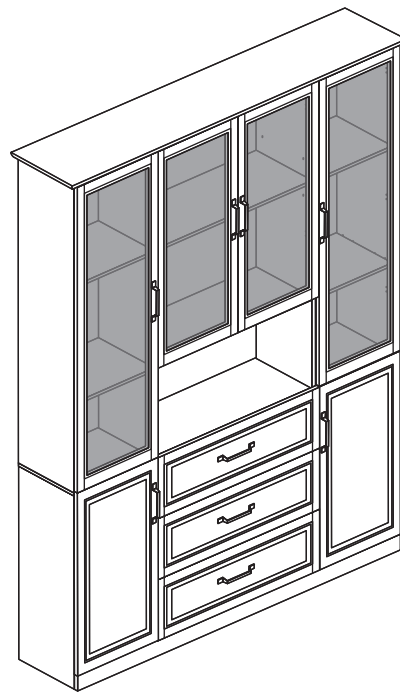
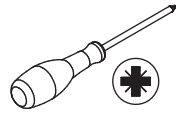

I

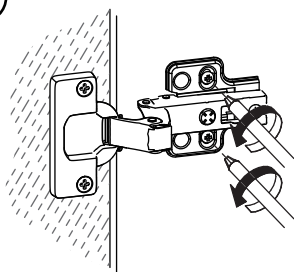

II

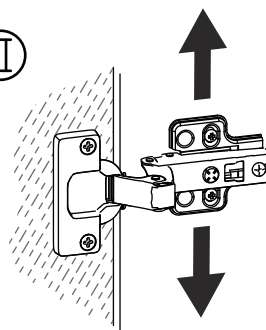

III

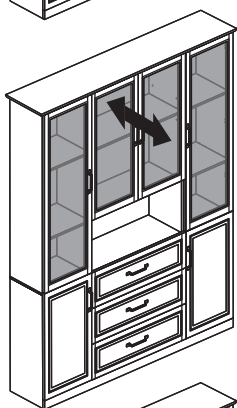
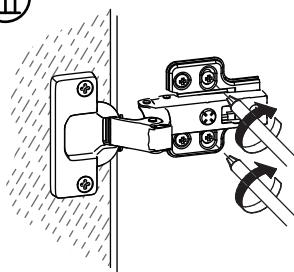

I

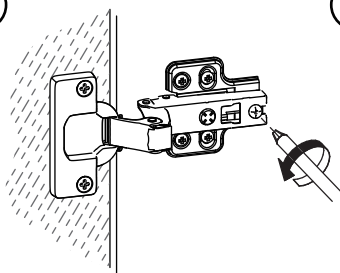

II

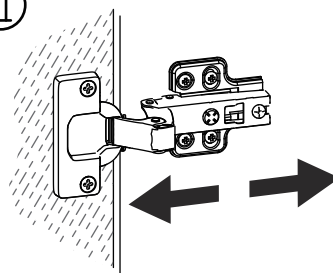

III

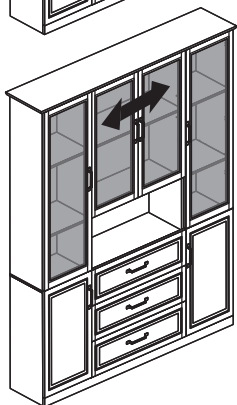
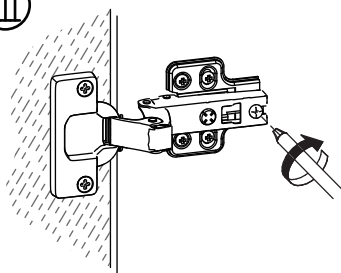

I

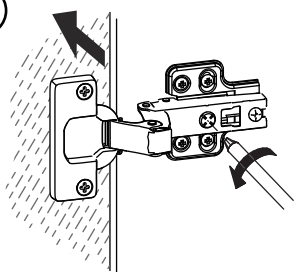

II

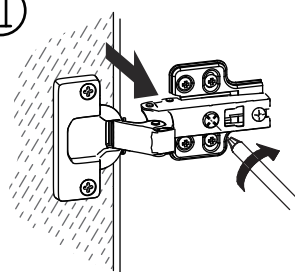

WARRANTY

WARRANTY CLAIMS

- There is a 30-day warranty for broken furniture or any other problems that do not work properly. The warranty will start from the date of purchase which must be verified by proof of purchase.
- Before making a claim, we may be able to answer your query, simply call us. Please leave your purchase order number, along with some details of the problem, if you want a replacement part. We will arrange within 48 hours. If there is out of stock, we will reply with a shipping date.
- The product must be used in accordance with the instructions provided. For health reasons.
- For other reasons, if the furniture needs to be returned, it must be cleaned and dried and operated within 30 days of receipt.

Type of Warranty Claim

- Failure to follow the furniture instructions will invalidate the warranty. Attention please.
- Does not include damage during installation, but includes damage during transportation.

Scope of responsibility

- Shall not bear any responsibility for misuse or user damage and / or loss of parts during the installation of furniture.
- After using, the damage and scratches of the furniture are not covered by the warranty.

The Warranty Relates to All Bought in The Us and Covers The Following Areas

- Sheet parts: 1 month from the date of purchase.
- Electrical parts: 1 month from the date of purchase.

GARANTIE

RÉCLAMATIONS DE GARANTIE

Il existe une garantie de 30 jours pour les meubles cassés ou tout autre problème qui ne fonctionne pas correctement. La garantie commencera à partir de la date d'achat qui doit être vérifiée par une preuve d'achat.

Avant de faire une réclamation, nous pourrions peut-être répondre à votre demande, il vous suffit de nous appeler. Veuillez laisser votre numéro de bon de commande, ainsi que quelques détails sur le problème, si vous voulez une pièce de rechange. Nous organiserons dans les 48 heures. En cas de rupture de stock, nous vous répondrons avec une date d'expédition.

Le produit doit être utilisé conformément aux instructions fournies. Pour des raisons de santé.

Pour d'autres raisons, si les meubles doivent être retournés, ils doivent être nettoyés et séchés et utilisés dans les 30 jours suivant leur réception.

Type de demande de garantie

Le non-respect des instructions du meuble annulera la garantie. Attention, s'il vous plaît. N'inclut pas les dommages pendant l'installation, mais inclut les dommages pendant le transport.

Portée de la responsabilité

N'assume aucune responsabilité en cas de mauvaise utilisation ou de dommages causés par l'utilisateur et / ou de perte de pièces lors de l'installation du meuble.

Après utilisation, les dommages et rayures du meuble ne sont pas couverts par la garantie.

La garantie s'applique à tous les produits achetés aux États-Unis, dans tous les pays d'Europe et couvre les domaines suivants:

Pièces en tôle: 1 mois à compter de la date d'achat.

Pièces électriques: 1 mois à compter de la date d'achat..

RETURNS

CHANGED YOUR MIND AND NEED TO RETURN YOU ITEM?

PLEASE FOLLOW THE BELOW INSTRUCTIONS:

- If you have purchased and have simply changed your mind, follow the retailer's instructions for returns.

DEFECTIVE ITEMS

- If your item is defective in any way, i.e. it doesn't work but you can't identify why, in the first instance, please call us.

DAMAGED ITEMS

- If you receive an order with obvious shipping damage from the retailer, then we suggest the delivery is refused. If the delivery has been accepted and then shipping damage is found, please follow the specific instructions advised by the retailer.
In all circumstances please save all packaging material and paperwork for the order. Please be aware that if you dispose of packaging material or attempt to return the merchandise without contacting the fulfiller, you jeopardise your chances of making a claim, and you may not receive a credit for the return.

RETOUR

VOUS AVEZ CHANGE D'AVIS ET VOUS AVEZ BESOIN DE RETOURNER VOTRE ARTICLE ?

VEUILLEZ SUIVRE LES INSTRUCTIONS CI-DESSOUS:

Si vous avez acheté et que vous avez simplement changé d'avis, suivez les instructions du détaillant pour les retours.

ARTICLES DÉFECTUEUX

Si votre article est défectueux de quelque manière que ce soit, c'est-à-dire qu'il ne fonctionne pas, mais que vous ne pouvez pas identifier pourquoi, en premier lieu, veuillez nous appeler.

ARTICLES ENDOMMAGÉS

Si vous recevez une commande avec des dommages d'expédition évidents du détaillant, nous suggérons que la livraison soit refusée. Si la livraison a été acceptée et que des dommages d'expédition sont constatés, veuillez suivre les instructions spécifiques conseillées par le détaillant.

Dans tous les cas, veuillez conserver tout le matériel d'emballage et les documents pour la commande.

Veuillez noter que si vous vous débarrassez du matériel d'emballage ou tentez de retourner le

Marchandise Sans contacter le remplisseur, vous compromettez vos chances de faire une réclamation, et vous ne pouvez pas recevoir de crédit pour le retour.

