

DESK

ASSEMBLY GUIDE

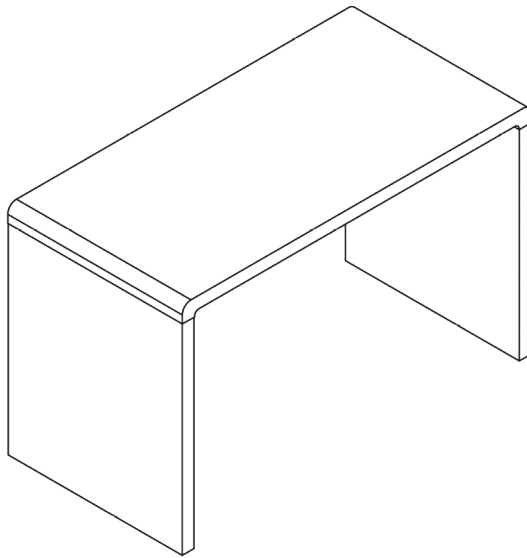

Important - Please read these instructions fully before starting assembly



**SAFETY AND
CARE ADVICE**



NO POWER TOOLS

SAFETY AND CARE ADVICE

- Check you have all the components and tools listed.
- Remove all fittings from the plastic bags and separate them into their groups.
- We do not recommend the use of power drills/drivers for inserting screws, as this could damage the unit. Only use hand screwdrivers and Allen keys.
- Keep children and animals away from the work area, small parts could cause choking if swallowed.
- Make sure you have enough space to layout the parts before starting.
- Assemble the item as close to its final position (in the same room) as possible.
- Do not overtighten the nuts to avoid causing damage to the threads.
- Only clean using a damp cloth and mild detergent, do not use bleach or abrasive cleaners.
- From time to time check that there are no loose screws on this unit
- This product should not be discarded with household waste. Take to your local authority waste disposal centre

IMPORTANT INFORMATION



45 MINUTE
BUILD











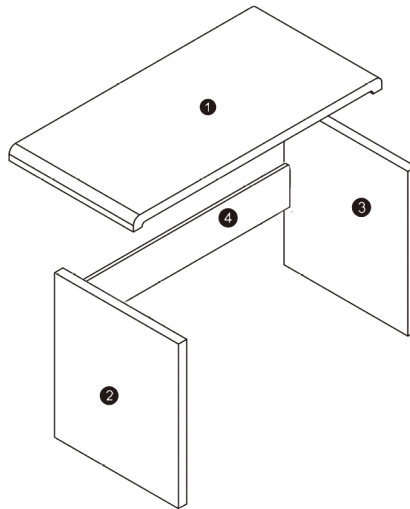

TWO
PERSON

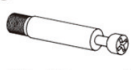

MAXIMUM
CAPACITY 100Kg

PLEASE CHECK CAREFULLY AND MAKE SURE YOU HAVE ALL FITTINGS AND TOOLS LISTED BELOW BEFORE YOU START.

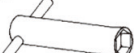

<p>A</p>  <p>M8x720mm x4</p>	<p>B</p>  <p>Ø6x40mm x8</p>	<p>C</p>  <p>Ø15x11mm x8</p>	<p>D</p>  <p>Ø30mm x12</p>	<p>E</p>  <p>M8x30mm x4</p>
<p>F</p>  <p>M8x22mm x4</p>	<p>G</p>  <p>M8 x4</p>	<p>H</p>  <p>M8 x1</p>	<p>I</p>  <p>X1 Screw Driver</p>	

NOTE: The quantities above are the correct amount to complete the assembly. In some cases more fittings may be supplied than are required.

STEP 1

Insert the wooden dowels (E) into the matching holes on Part [1], screw the threaded rods (A) into the matching holes on Part [1]. screw the connecting rods (B) into the matching holes on Part [1], [2], [3].

ATTENTION: Be careful to always insert the threaded rods into the desk stopper-end first & don't screw past the stopper

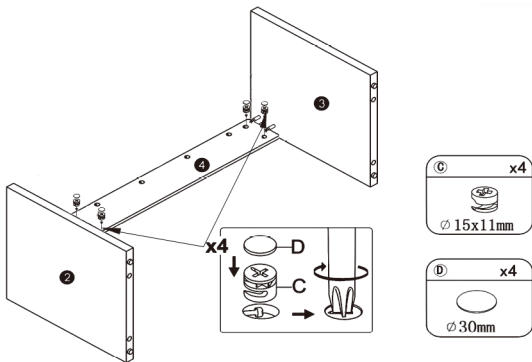
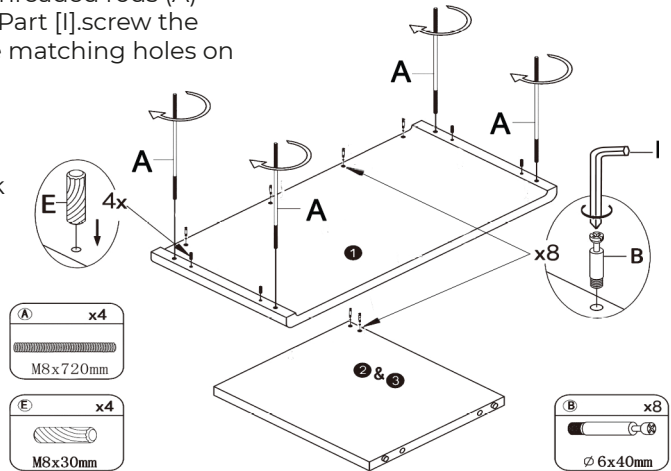

STEP 2

Use fitting (C) to connecting Part [2], [3], [4]; once fully tightened cover the holes with stickers (D).

FULL ASSEMBLY INSTRUCTIONS

STEP 3

Install the assembly Part [2], [3], [4] to the Part [1] through the threaded rods E, secure using fixing (G), (F), using box spanner (H) to tighten.

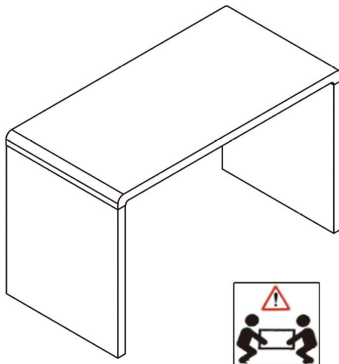
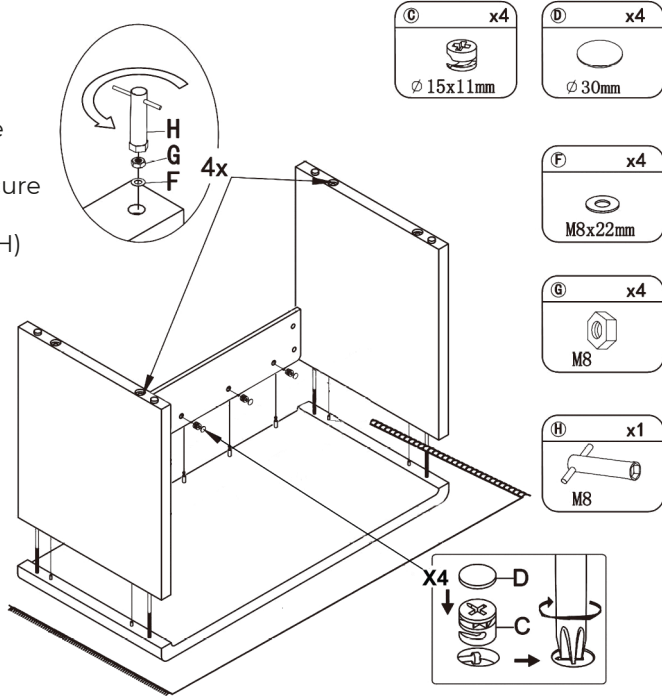

STEP 4

ATTENTION: With help, turn the table around to complete assembly