

OPEN BED FRAME

QUEEN ASSEMBLY INSTRUCTIONS



PARTS LIST

①	FOOT RAIL	1 PC
②	LEFT LEG	1 PC
③	RIGHT LEG	1 PC
④	SIDE RAILS	2 PCS
⑤	SLAT KIT	2 SETS
⑥	SLAT SUPPORT 1	1 PC
⑦	SLAT SUPPORT 2	1 PC
⑧	SUPPORT LEGS	3 PCS

HARDWARE

①	JCB M6 X 110mm (4 3/8") - 2 pcs Spare - 1 pc	⑤	JCB M6 X 25mm(1") - 6pcs
②	Barrel nut - 2 pcs	⑥	Cap nut - 6pcs
③	JCB M8 X 15mm (5/8") - 4 pcs	⑦	Allen Screw - 3pcs
④	Wood screw(1 1/4") - 29 pcs Spare - 2 pcs	⑧	Allen wrench M6 - 1pc
		⑨	Allen wrench M4 - 1pc Spare - 1pc

NOTE: WE INCLUDE SPARE HARDWARE IN CASE DAMAGE OCCURS DURING ASSEMBLY.

Step 1

Attach the legs (2) and (3) to foot rail (1), using JCB M6 X 110mm (A) and barrel nut (B).
Tighten with the Allen wrench M4 (I).

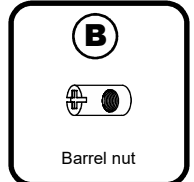
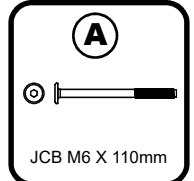
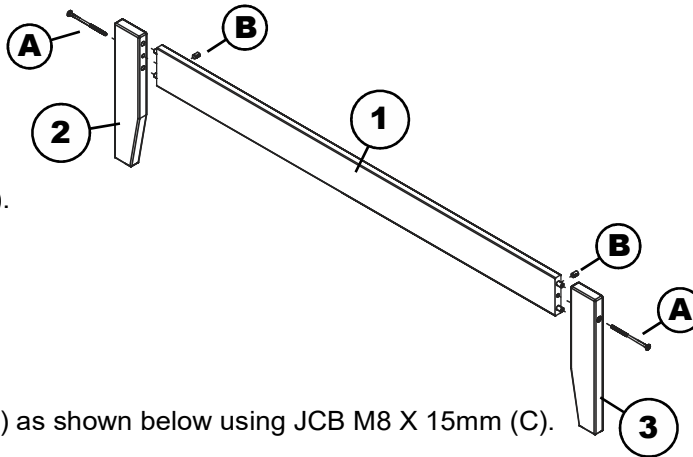

Step 2

Attach side rails (4) to the foot rail (1) as shown below using JCB M8 X 15mm (C).
Tighten with Allen wrench M6 (H).

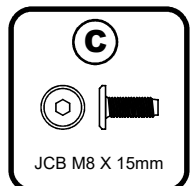
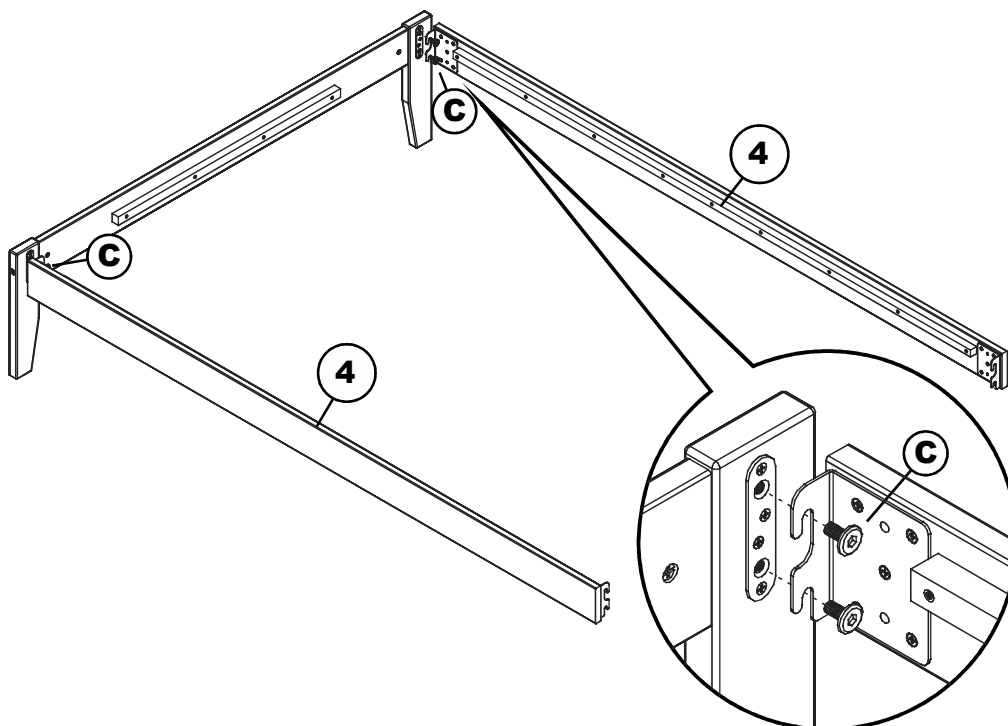

OPEN BED FRAME

QUEEN



Step 3

Attach open bed frame to the headboard as shown below using 4 JCB M8 X 15mm bolts that are supplied with your headboard. Tighten with the Allen wrench M6 (E).

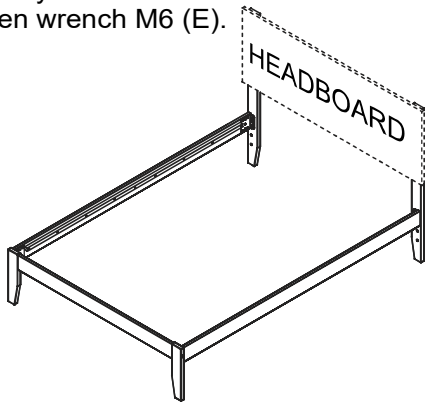
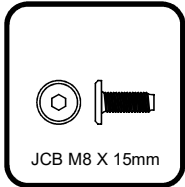

Step 4

Attach support legs (8) to slat support 1 & 2 (6)(7) as shown below. Using allen screw (G) tighten with Allen wrench M4 (I).

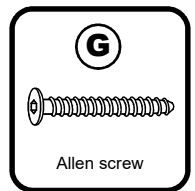
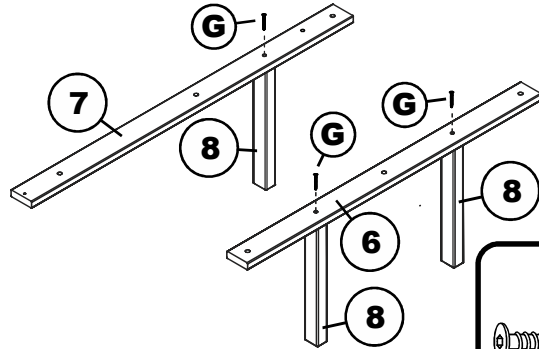

Step 5

Attach slat support 1(6) and slat support 2 (7) to the slat kit (5) as shown below using JCB M6 X 25mm (E) and cap nut (F). Tighten with Allen wrench M4 (I).

2 legs at headboard section.

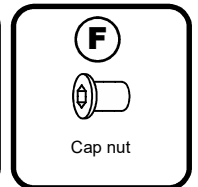
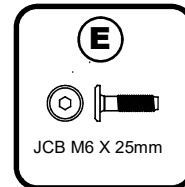
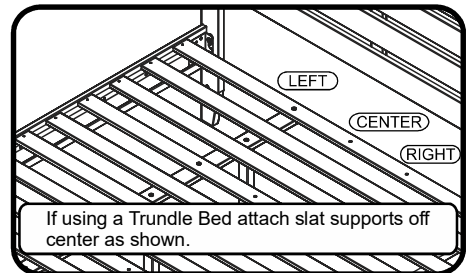
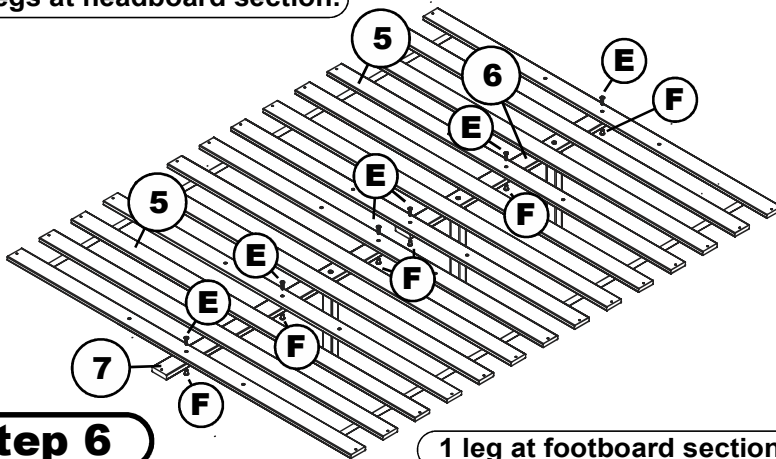

Step 6

Attach 2 slat kits (5) to the open bed frame as shown below using wood screws 1 1/4" (D). Tighten with Phillips head screw driver. (customer supplied)

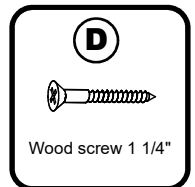
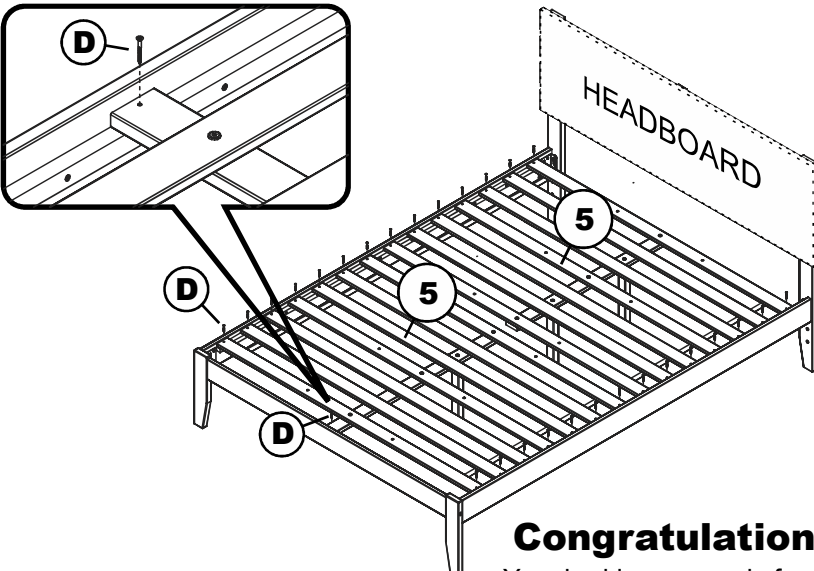

Congratulations!

Your bed is now ready for use.

We recommend that you periodically recheck that all screws are tight to ensure lasting safety.

BED DRAWER

QUEEN

ASSEMBLY INSTRUCTIONS

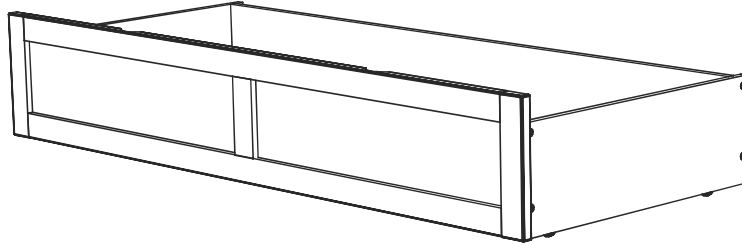
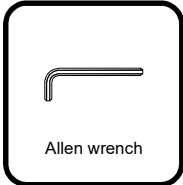

NOTE: WE INCLUDE SPARE HARDWARE IN CASE DAMAGE OCCURS DURING ASSEMBLY.

HARDWARE



(A) JCB M6 X 1" (25mm) - 8 pcs
Spare - 1 pc



(B) Wood Screw X 1 1/4" (32mm) - 2 pcs
Spare - 1 pc



(C) Allen wrench - 1 pc
Spare - 1 pc

PARTS LIST

- (01) HARDWARE 1 BOX**
- (02) DRAWER FACE 1 PC**
- (03) DRAWER SIDE 2 PCS**
- (04) DRAWER BACK 1 PC**
- (05) DRAWER BOTTOM 2 PCS**
- (06) DRAWER MIDDLE 1 PC**
- (07) DRAWER CENTER SUPPORT 1 PC**

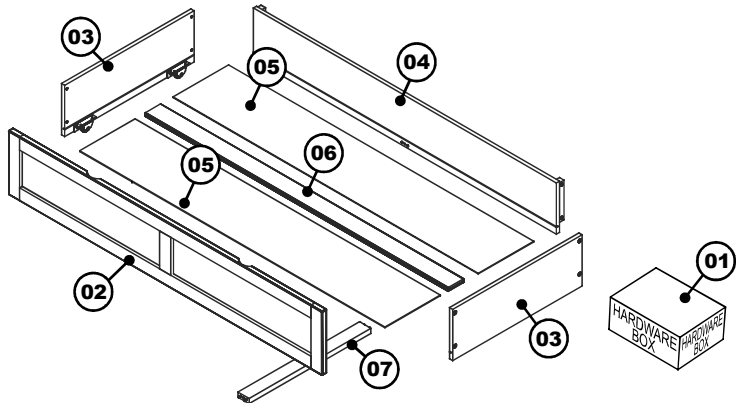

Step 1 Lay the drawer face (02) on smooth, flat surface so the drawer bottom (05) groove is facing upwards. Attach the drawer sides (03) to drawer face (02) using JCB M6 X 1" (A). Align groove inside drawer side with groove in drawer face. Tighten with Allen wrench (C).

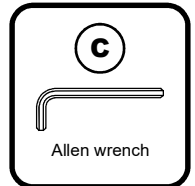
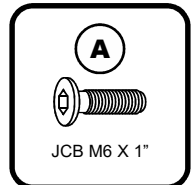
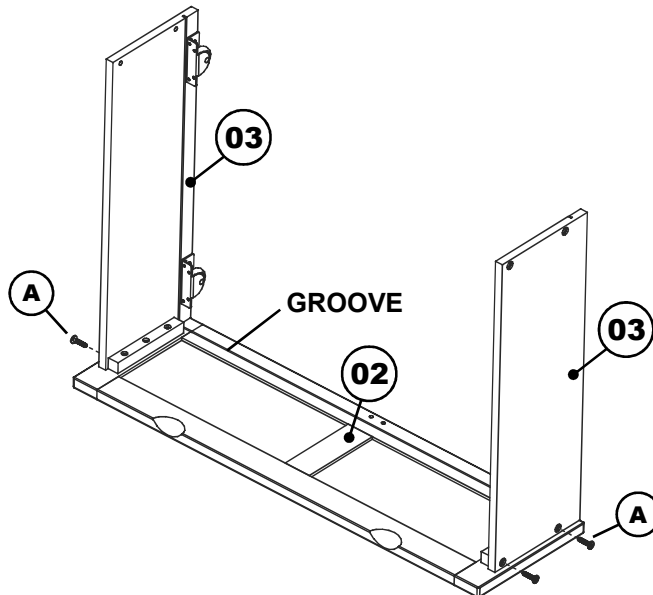

BED DRAWER

QUEEN

Step 2

Guide the drawer bottoms (05) and drawer middle (06) in carefully so that they align inside grooves. Be sure it fits fully into the face and side groove before attaching the drawer back (04).

Attach drawer center support (07) to bottom of drawer face using wood screw 1 1/4" (B). Tighten with Phillips head screw driver. (Customer supplied)

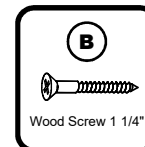
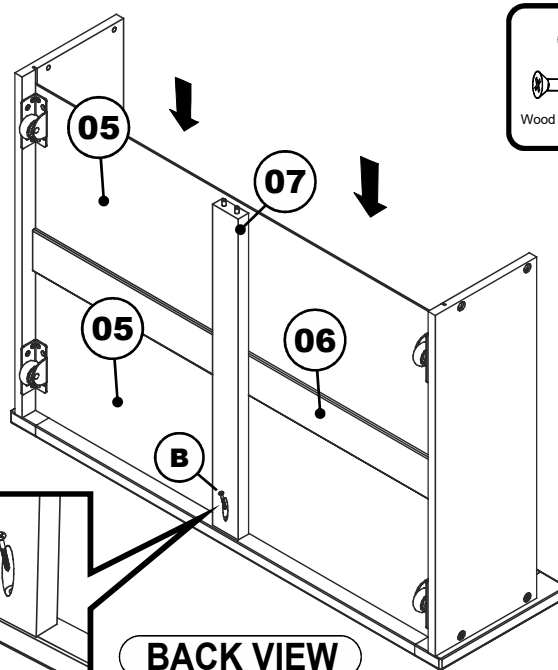
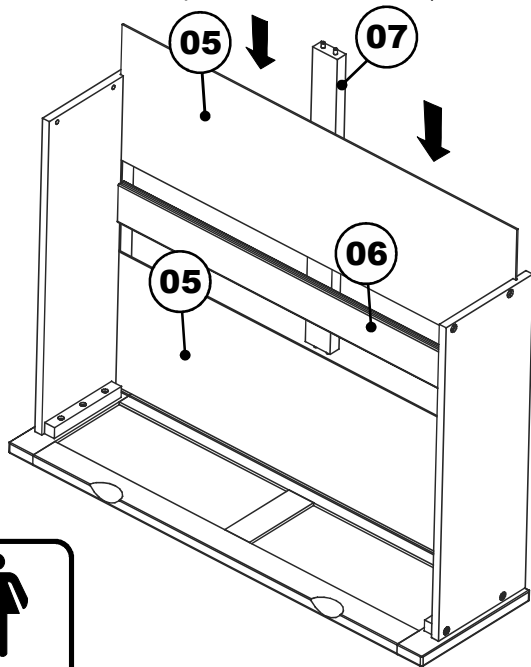

Step 3

Attach drawer back (04) to bed drawer assembly as shown. Use JCB M6 X 1" (A). Tighten with Allen wrench (C). Use wood screws 1 1/4" (B) to finish attaching drawer center support (07) to drawer back (04). Tighten with Phillips head screw driver. (customer supplied)

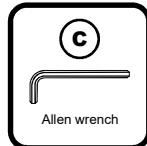
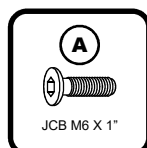
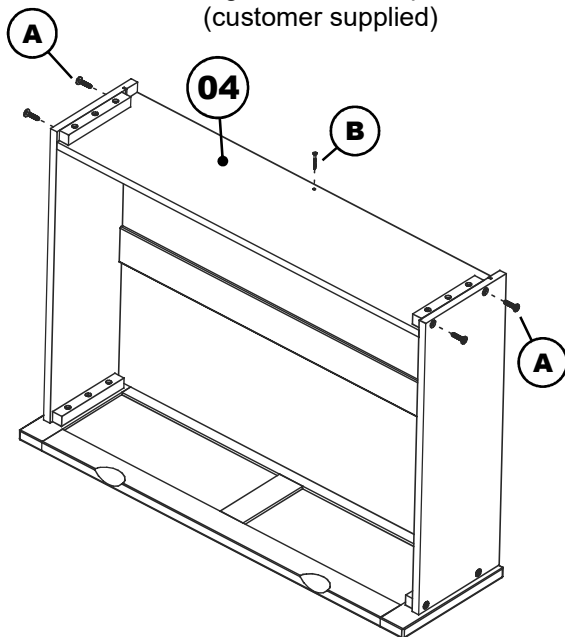

Step 4

Lastly, insert bed drawer to the bed as shown below.

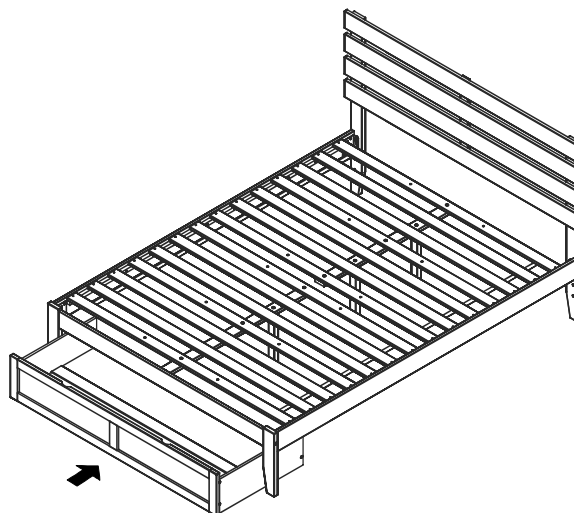

Congratulations!

Your bed drawer is now ready for use.

We recommend that you periodically recheck that all screws are tight to ensure lasting safety.

