

# Assembly Instruction

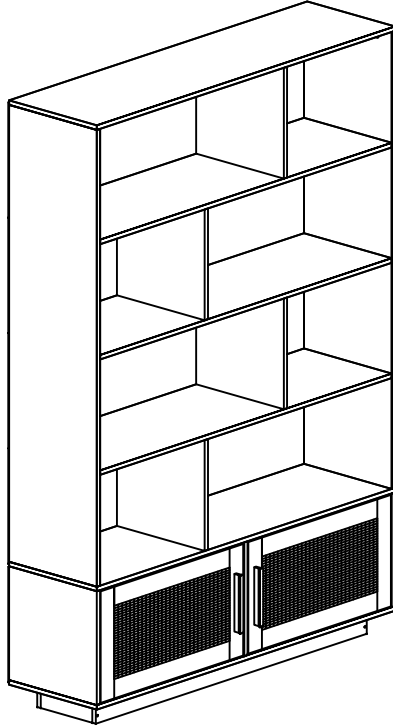

## Trouble shooting:

Missing / Wrong / Broken parts and installation issues



Send email with your question ,order NO. and screenshot of order details to:



Respond within 24 hours



Issue resolved

# COMPONENTS ID Nr.

Part Nr.	Qty	Part Nr.	Qty	Part Nr.	Qty
1	1pcs	2	1pcs	3	1pcs
4	1pcs	5	1pcs	6	2pcs
7	1pcs	8	4pcs	9	1pcs
10	1pcs	11	1pcs	12	2pcs
13	2pcs	14	1pcs	15	1pcs
16	1pcs	17	2pcs	18	2pcs
19	1pcs				

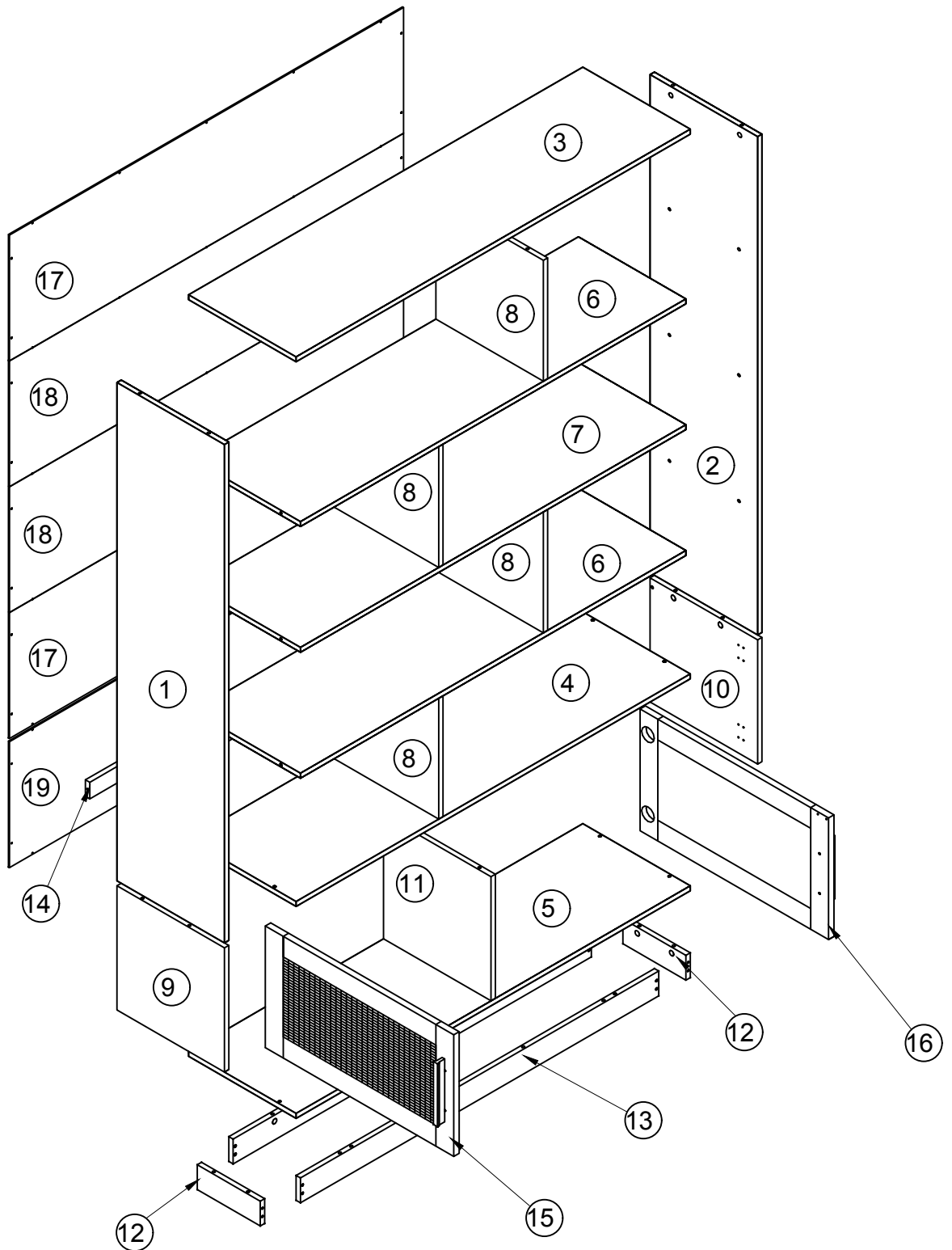

# HARDWARE LIST

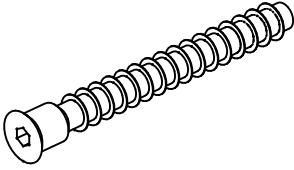
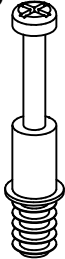
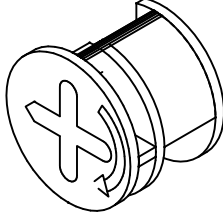
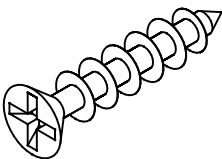
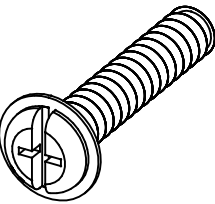
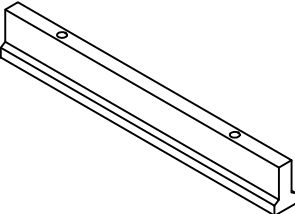
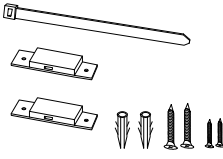
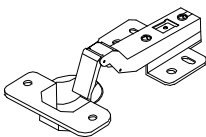
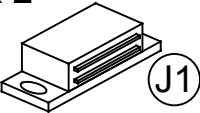
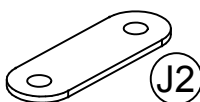
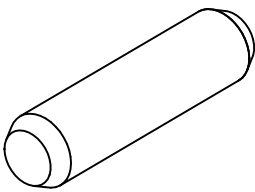
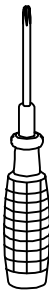
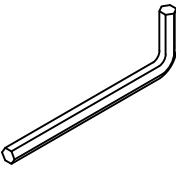
<p>(A) x 19</p>  <p>D5X40MM</p>	<p>(B) x 50</p>  <p></p>	<p>(C) x 50</p>  <p></p>	<p>(D) x 87</p>  <p>D3.5X12MM</p>
<p>(E) x 4</p>  <p>M4X18MM</p>	<p>(F) x 2</p>  <p></p>	<p>(G) x 2</p>  <p></p>	<p>(H) x 4</p>  <p></p>
<p>(J) x 2</p>  <p>J1</p>  <p>J2</p>	<p>(K) x 6</p>  <p></p>	<p>(L) x 1</p>  <p></p>	<p>(M) x 1</p>  <p>3#</p>

# HARDWARE LIST

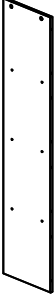
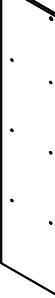
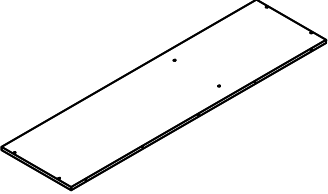
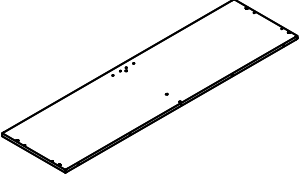
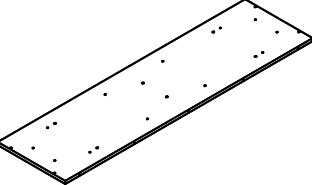
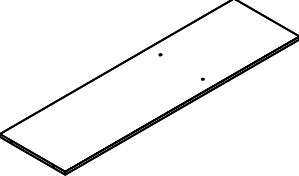
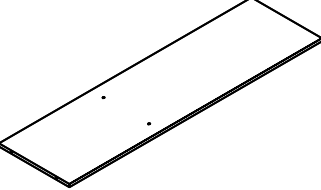
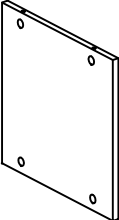
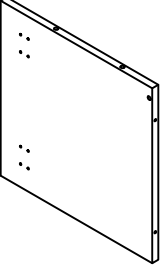
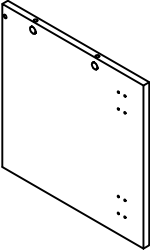
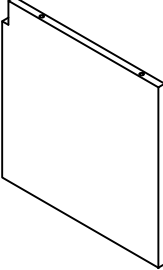
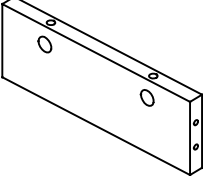
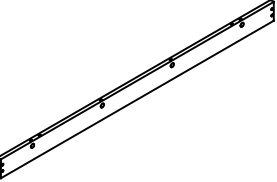
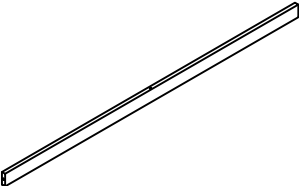
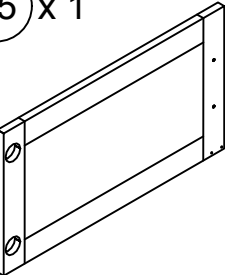
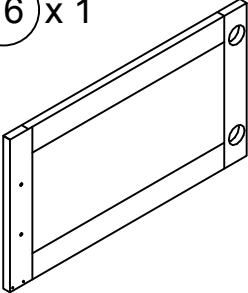
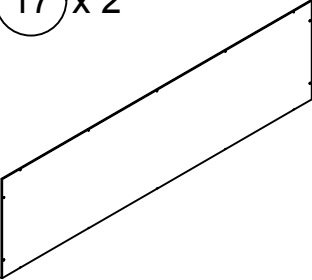
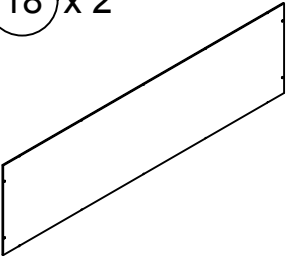
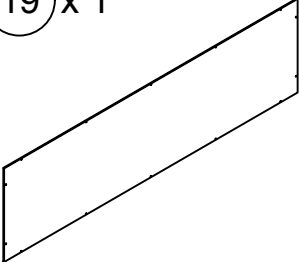
① x 1 	② x 1 	③ x 1 	④ x 1 
⑤ x 1 	⑥ x 2 	⑦ x 1 	⑧ x 4 
⑨ x 1 	⑩ x 1 	⑪ x 1 	⑫ x 2 
⑬ x 2 	⑭ x 1 	⑮ x 1 	⑯ x 1 
⑰ x 2 	⑱ x 2 	⑲ x 1 	

1

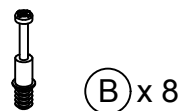

Turn the panel over

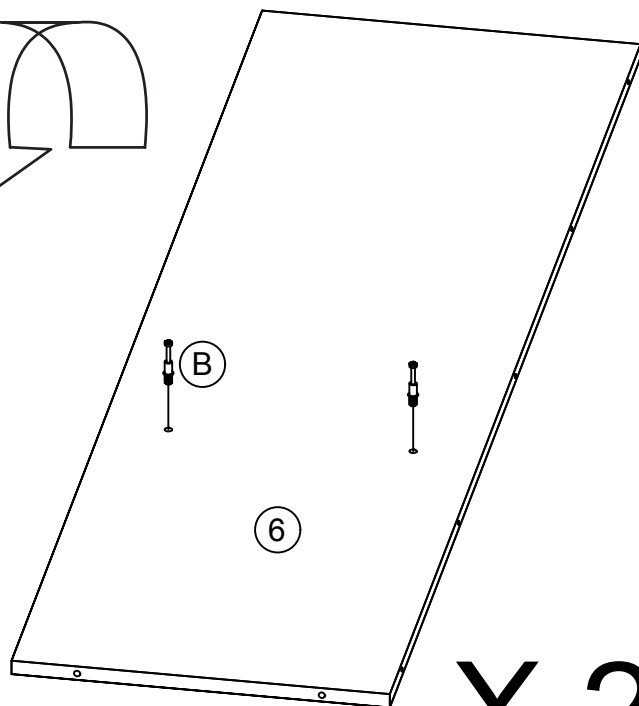
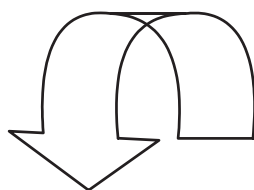
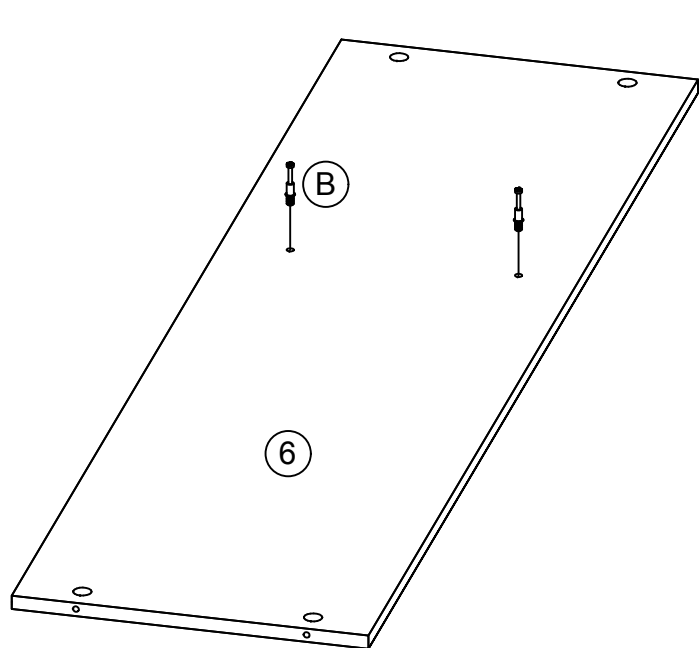

X 2

2

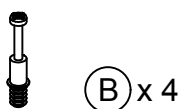

Turn the panel over

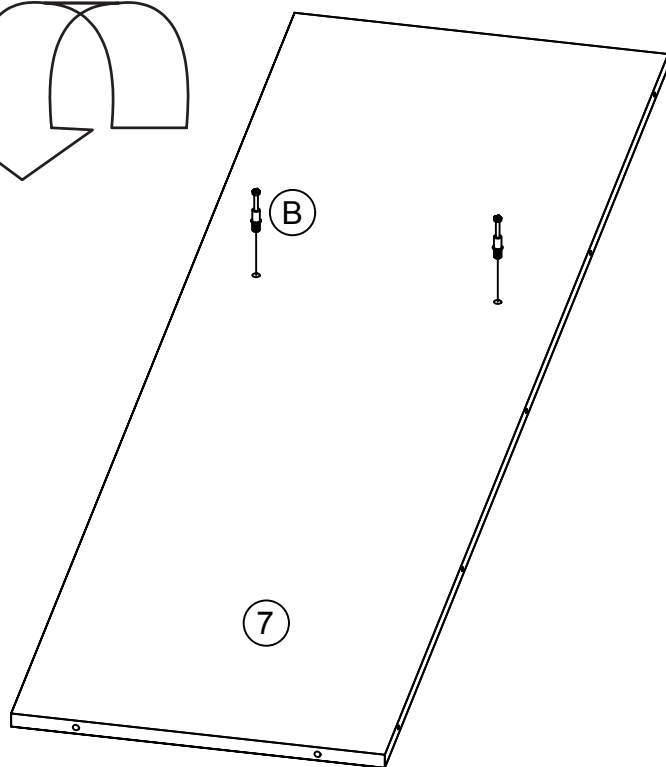
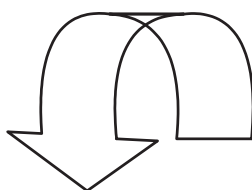
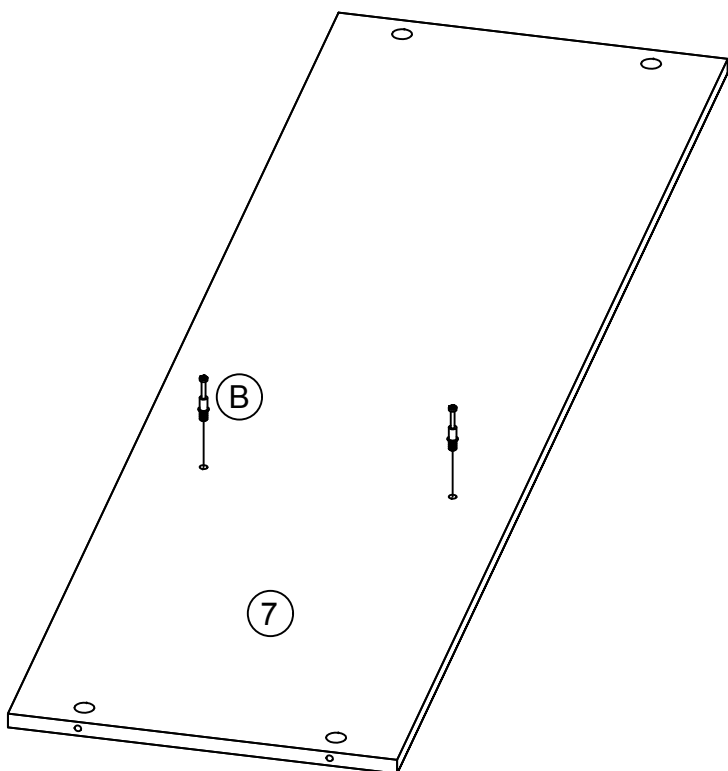

3



(C) x 12

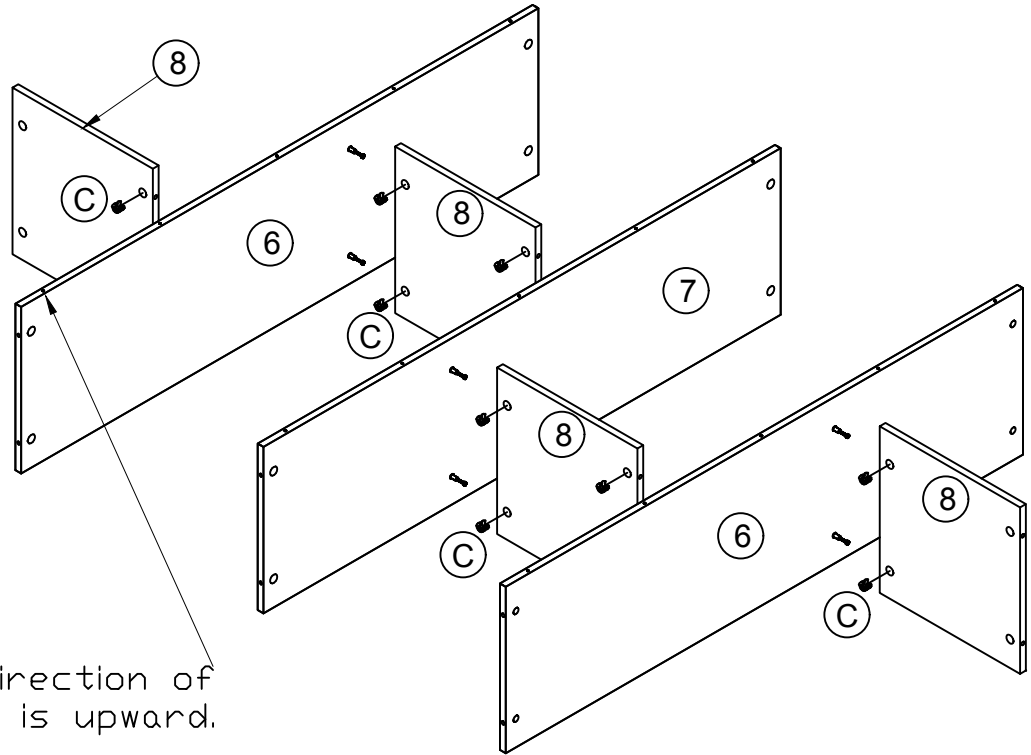

Noted the direction of backpanel holes is upward.

4

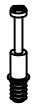

(B) x 12

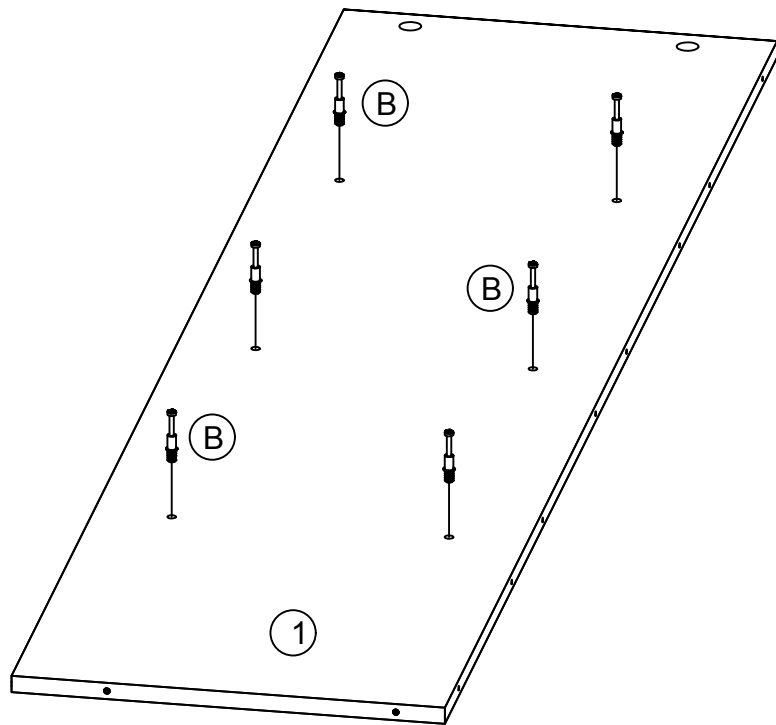
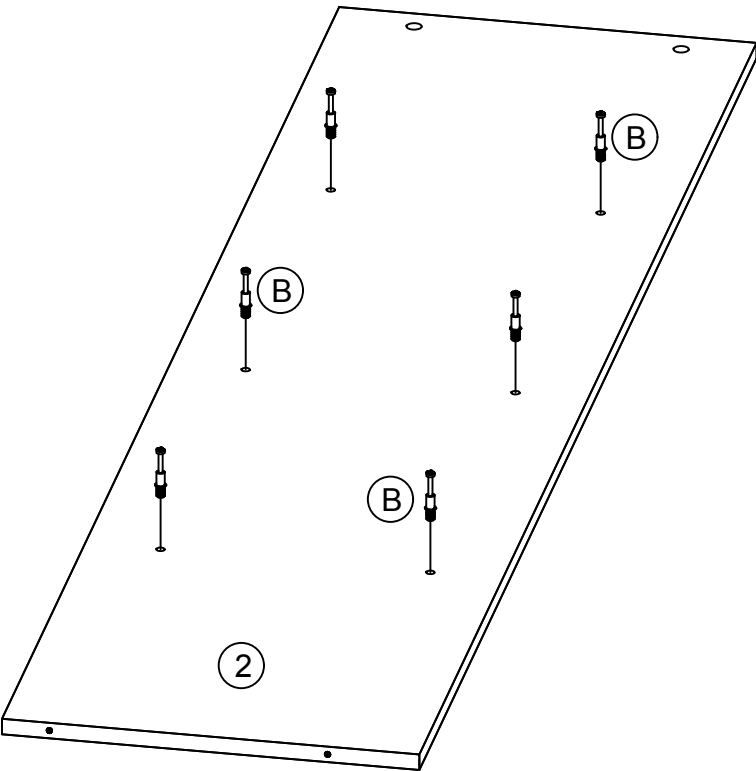

5



(C) x 12

Noted the direction of the holes.

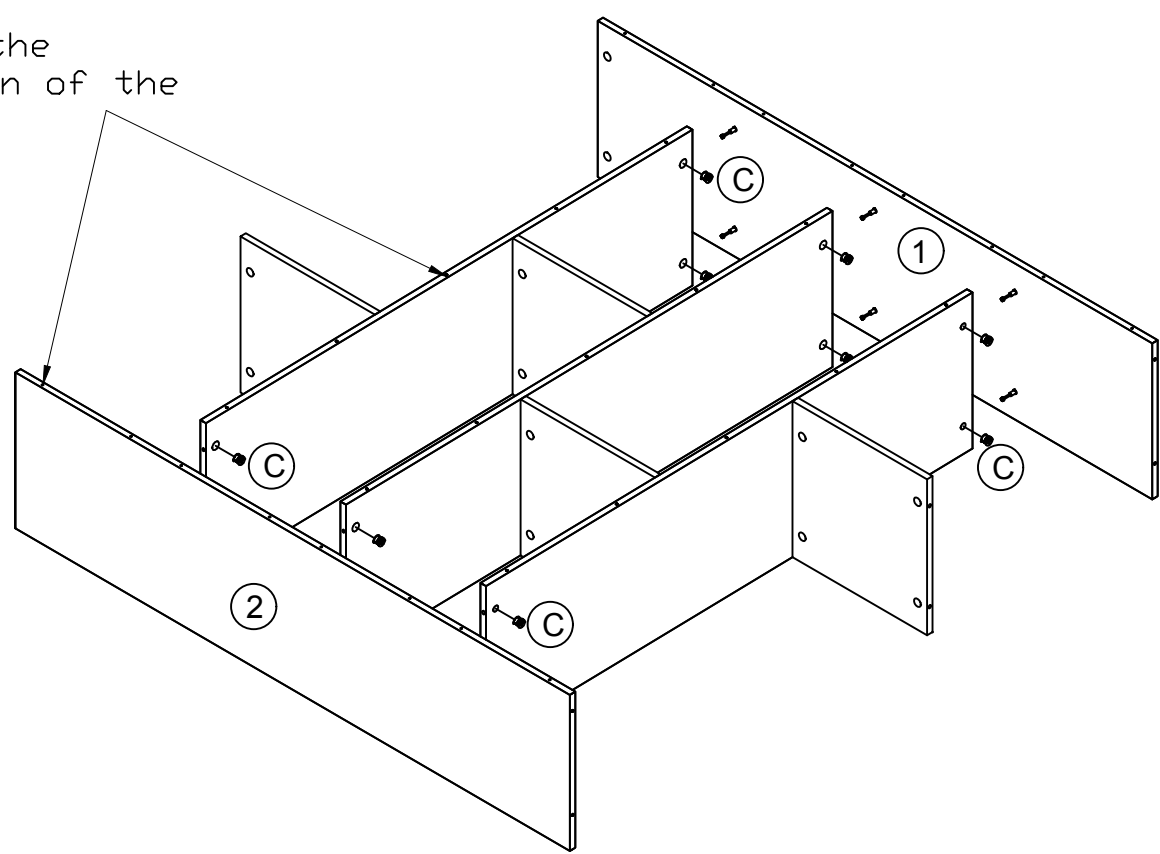

6

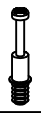

(B) x 6

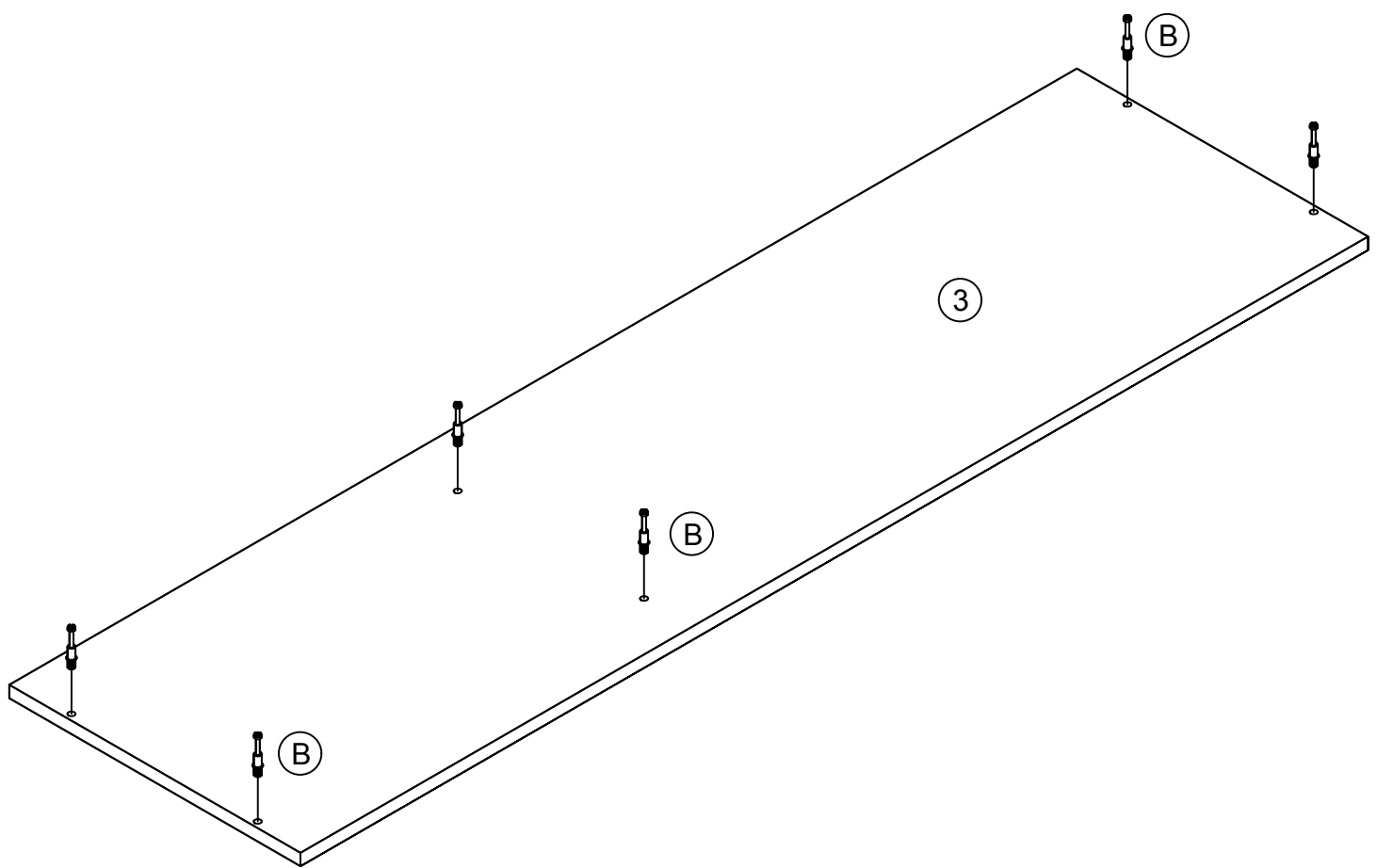

7



Noted the direction.

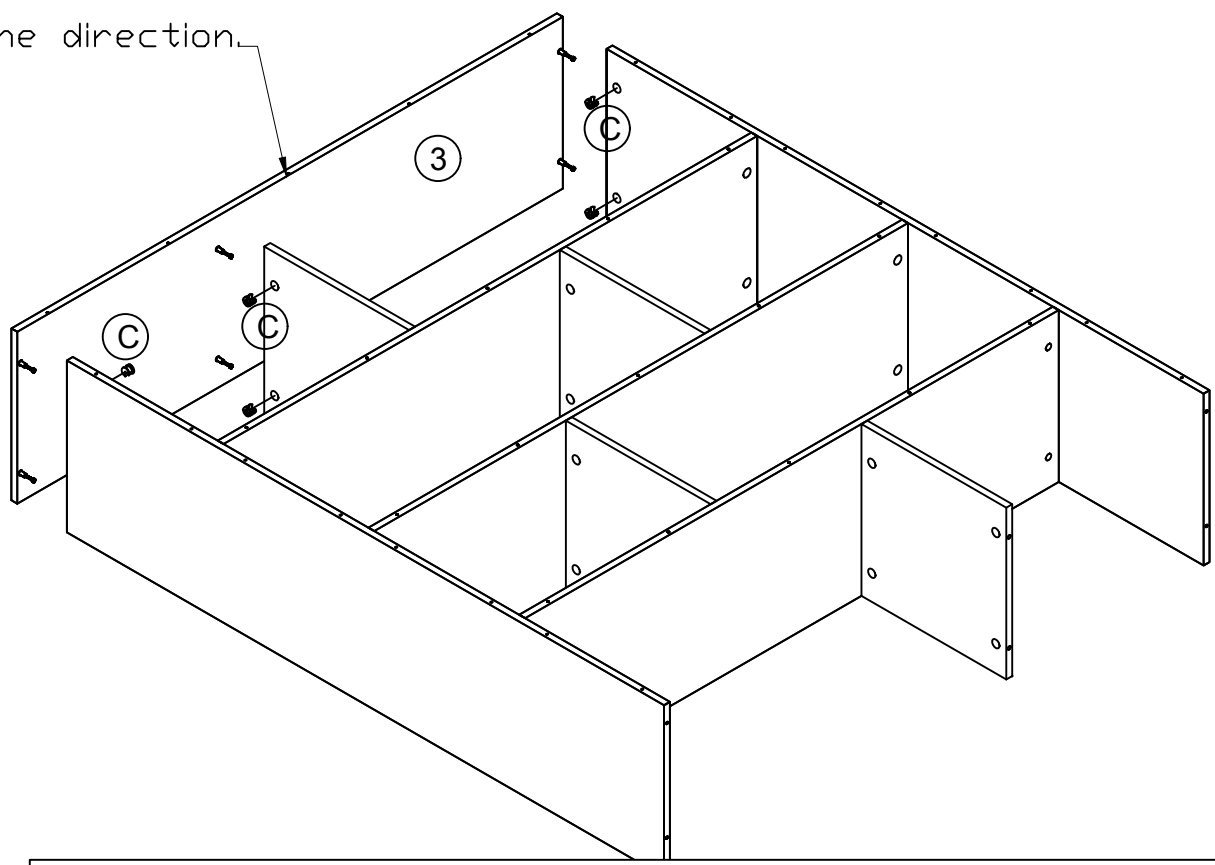

8

D3.5X12MM

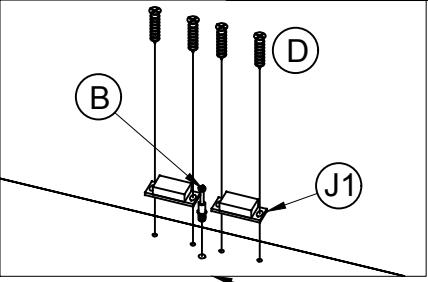

Turn the panel over

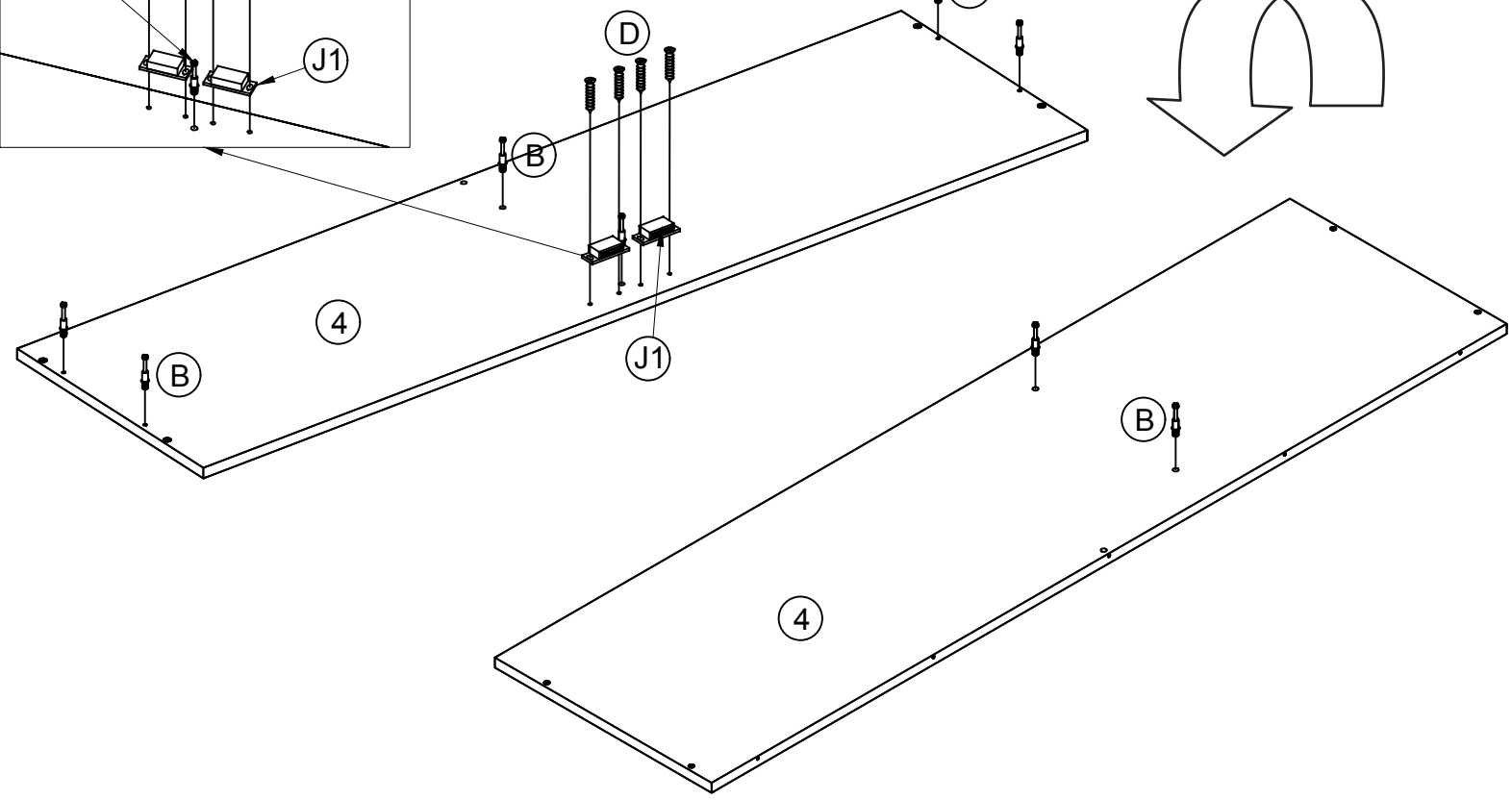
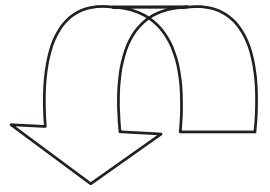

9

D5X40MM



(A) x 4



(C) x 2

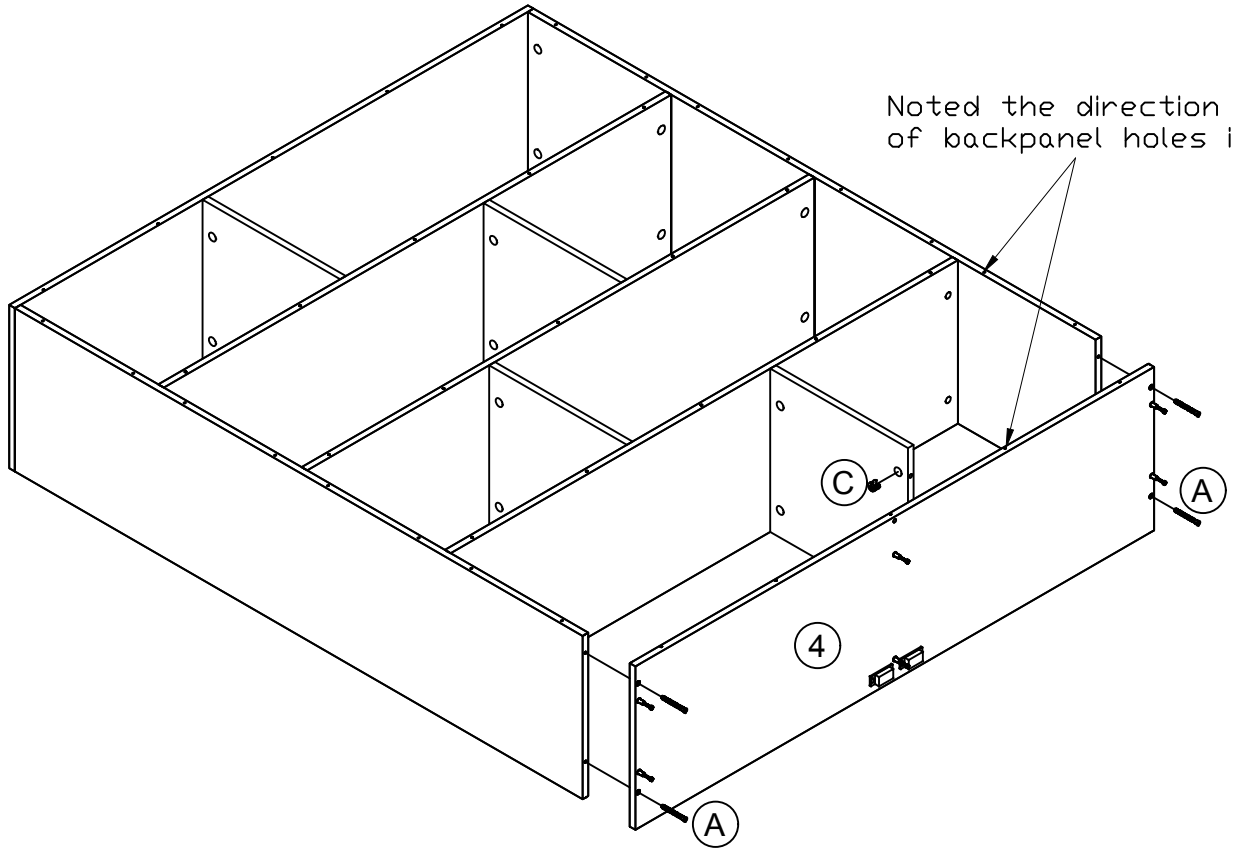

10



(K) x 2

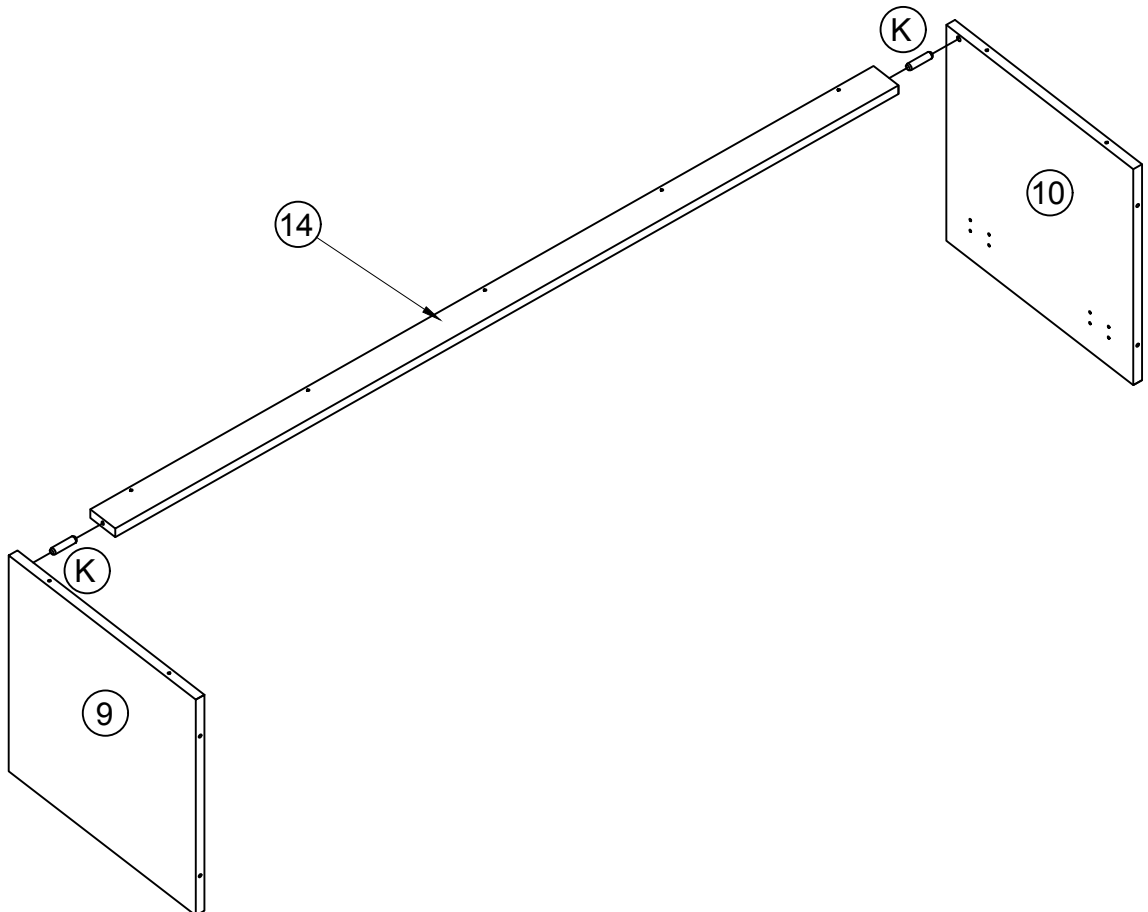

11

D5X40MM



(A) x 1



(C) x 4

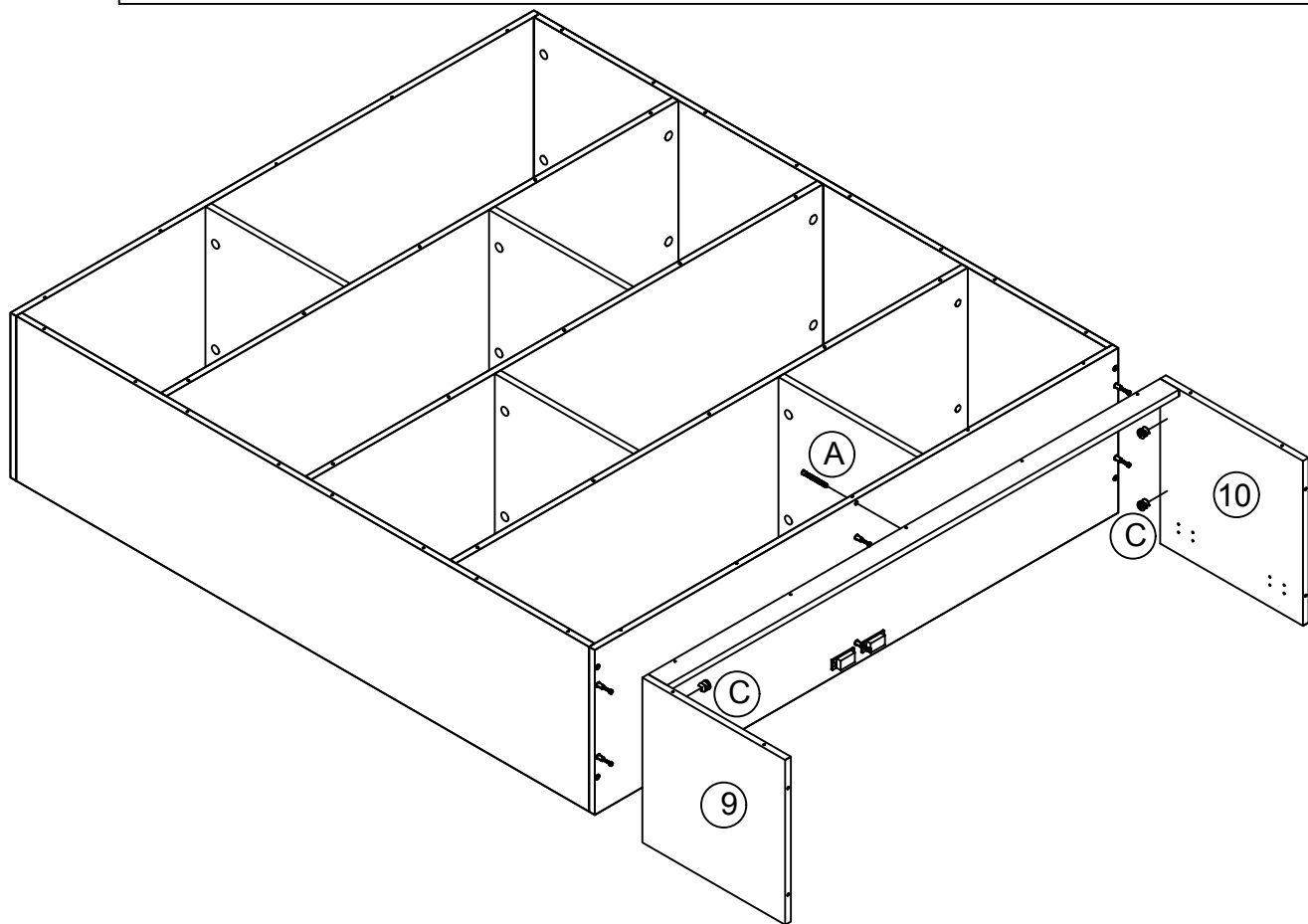

12



(C) x 2

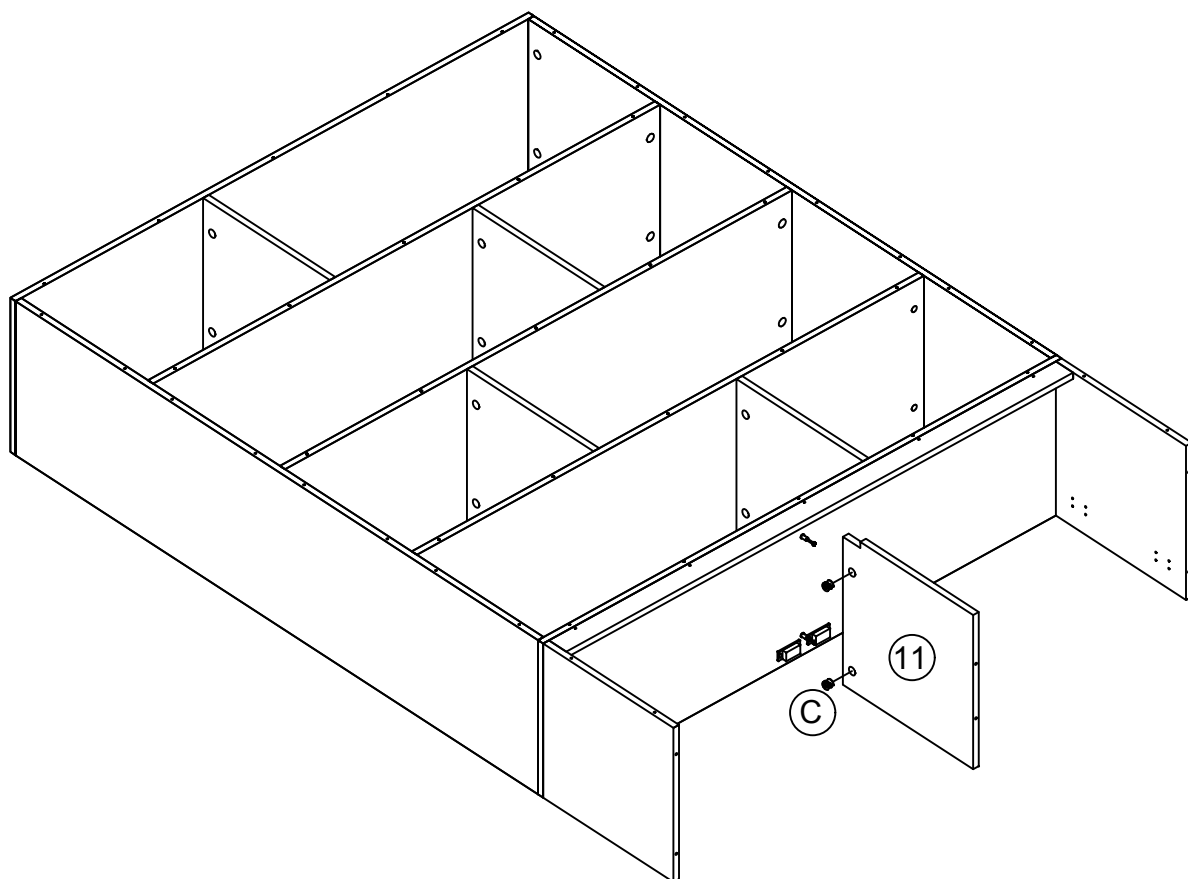

13

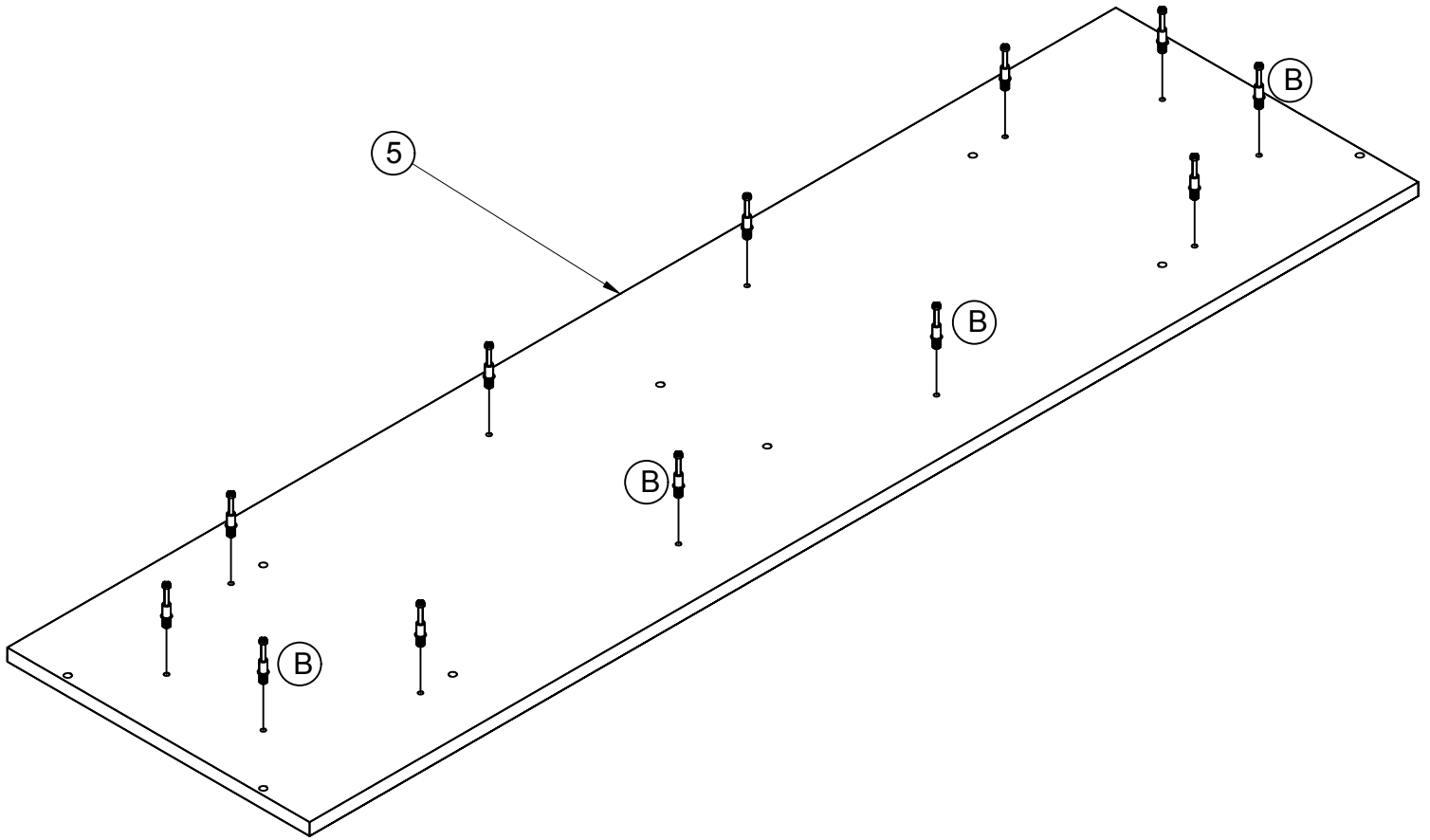

14

D5X40MM

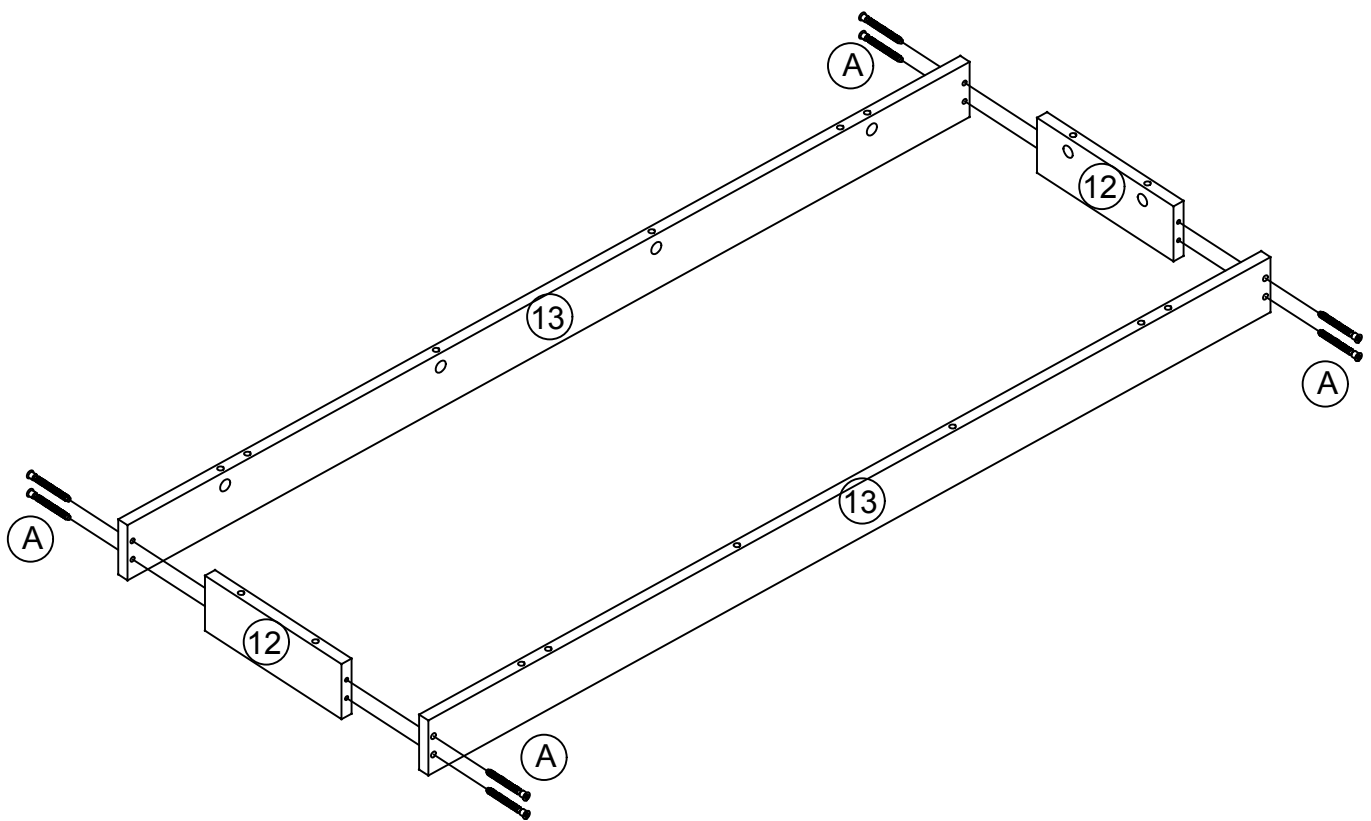

15

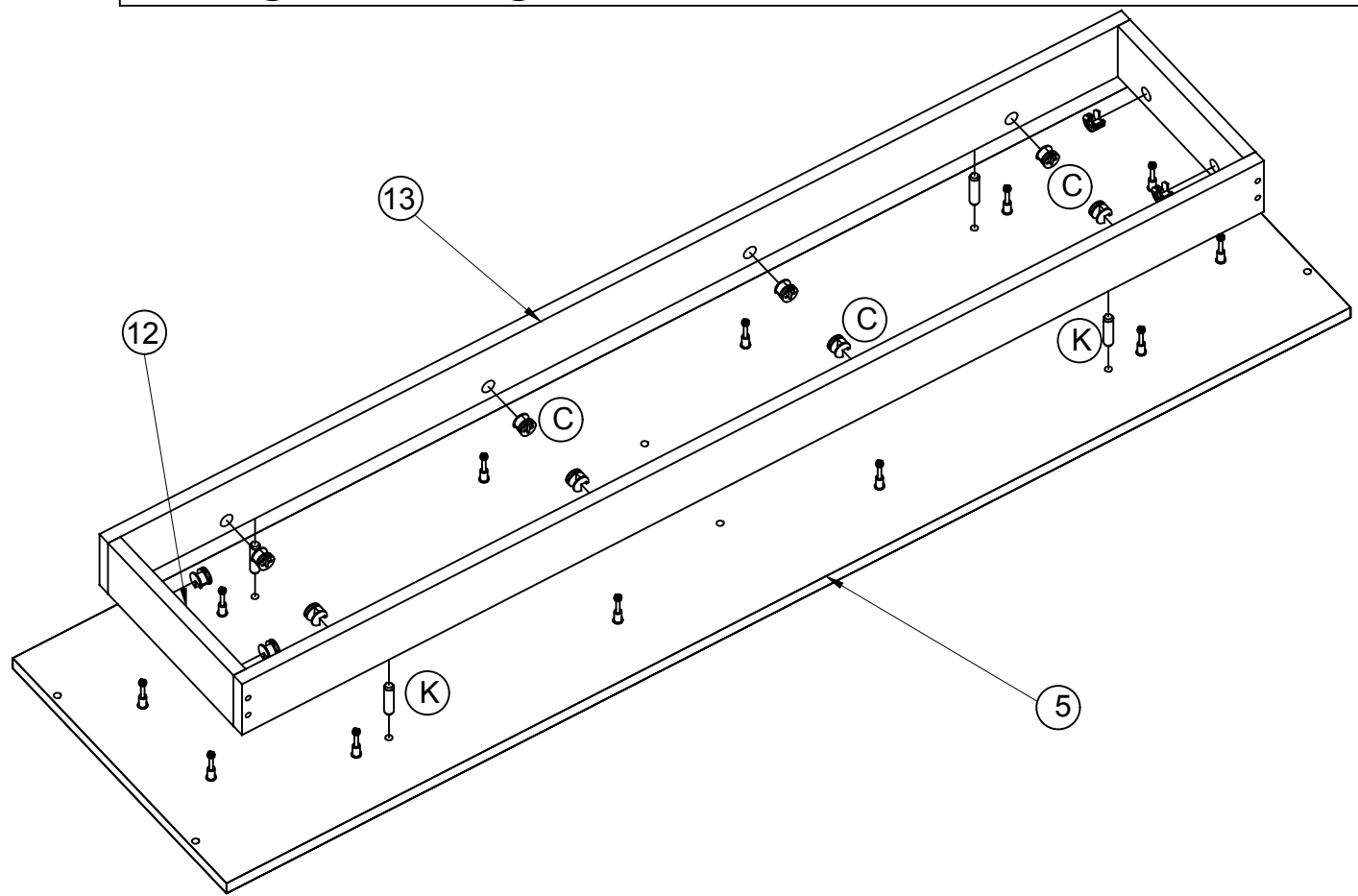
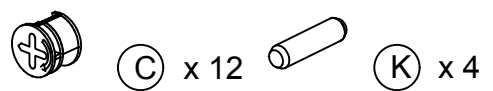

16

D5X40MM

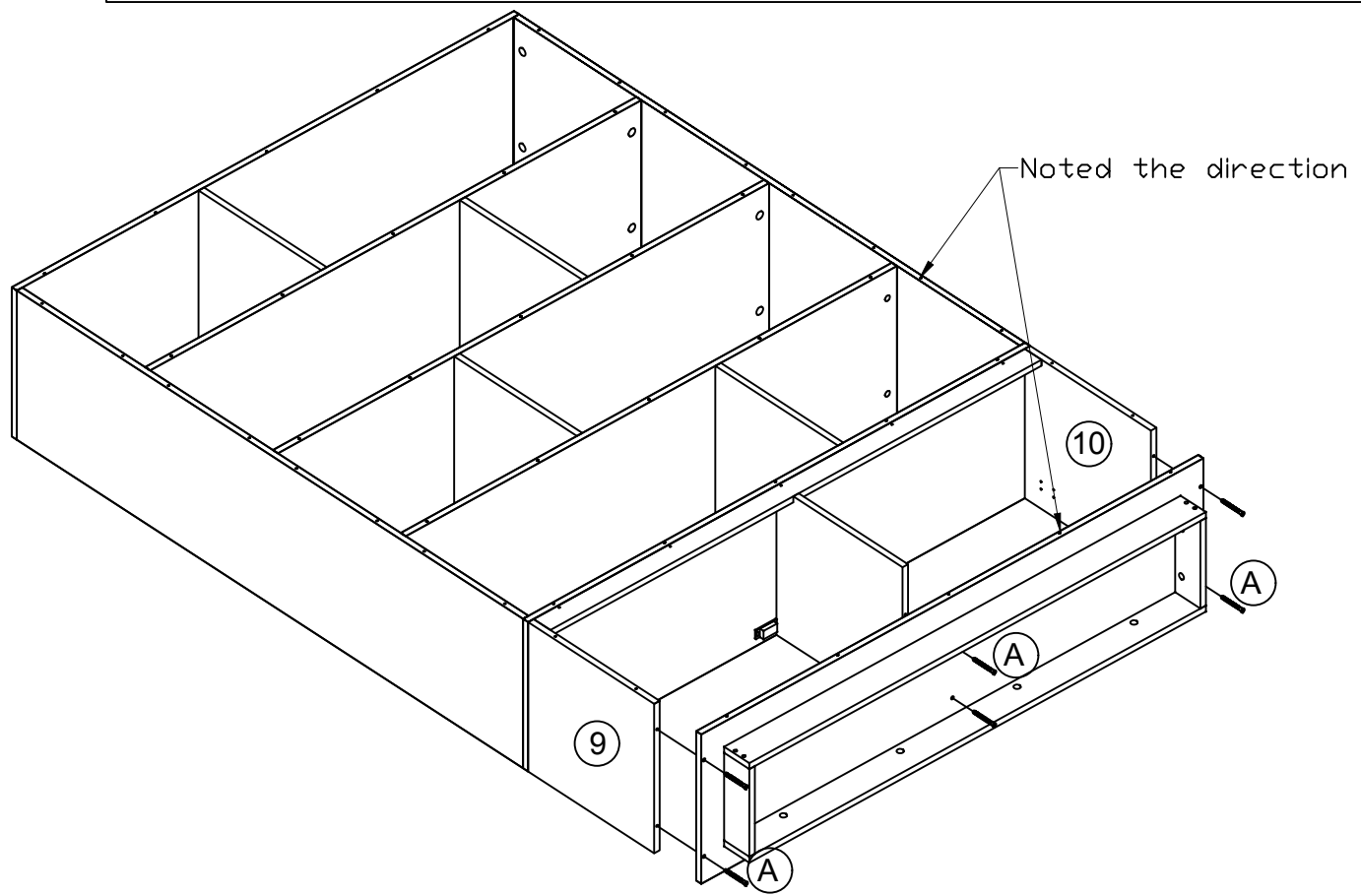
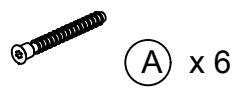

17

D3.5X12MM



(D) x 55

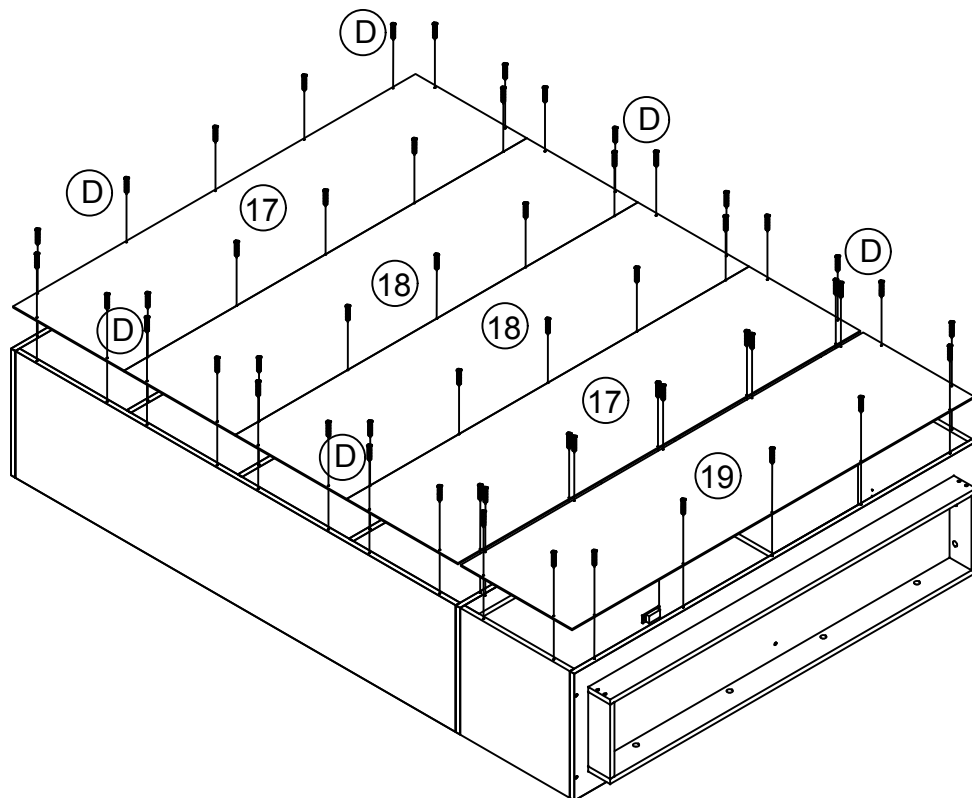

18

M4X18MM

D3.5X12MM



(E) x 4



(D) x 12



(F) x 2

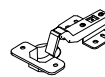

(H) x 4



(J2) x 2

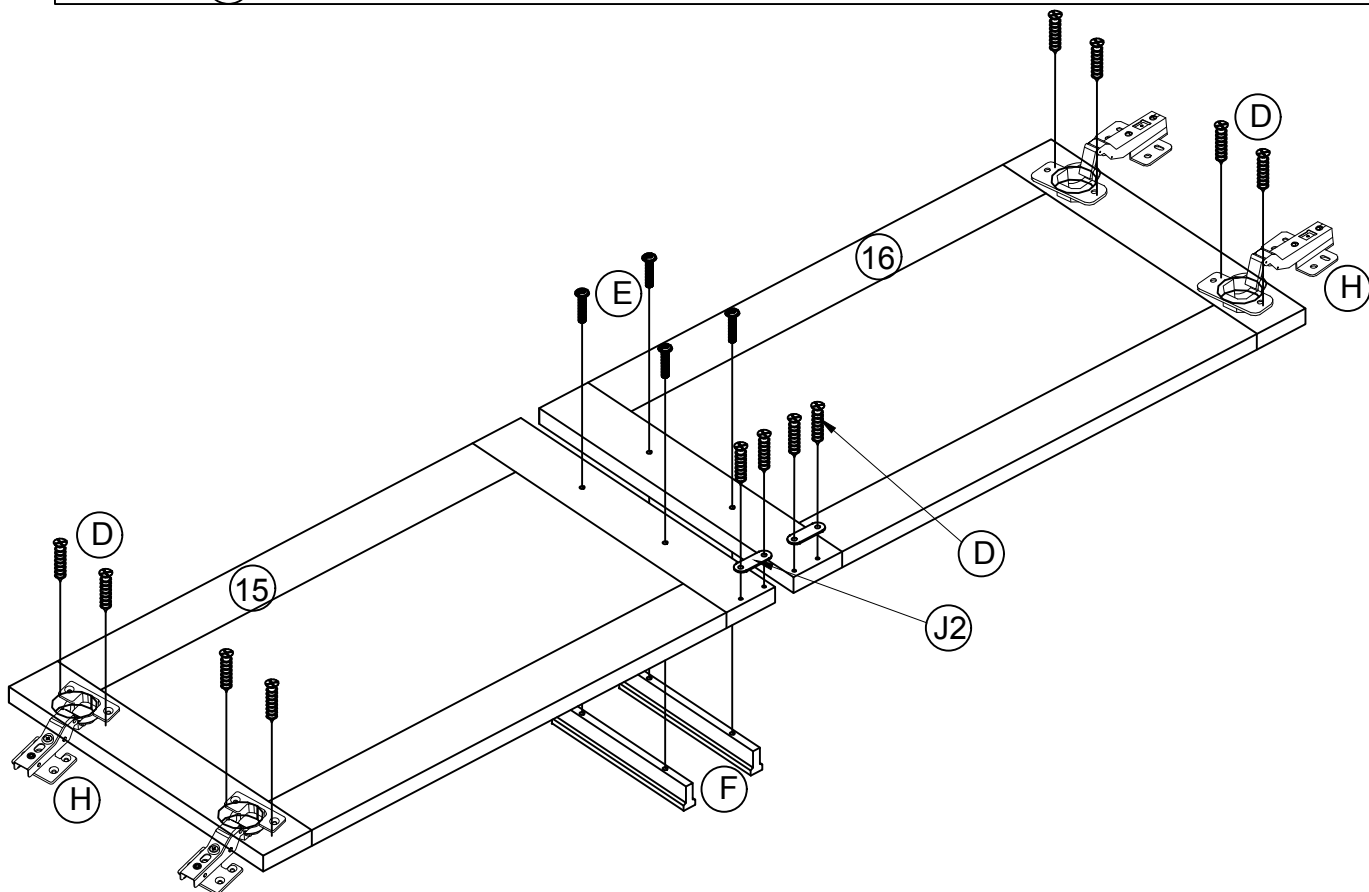

19

D3.5X12MM



ⓓ x 16

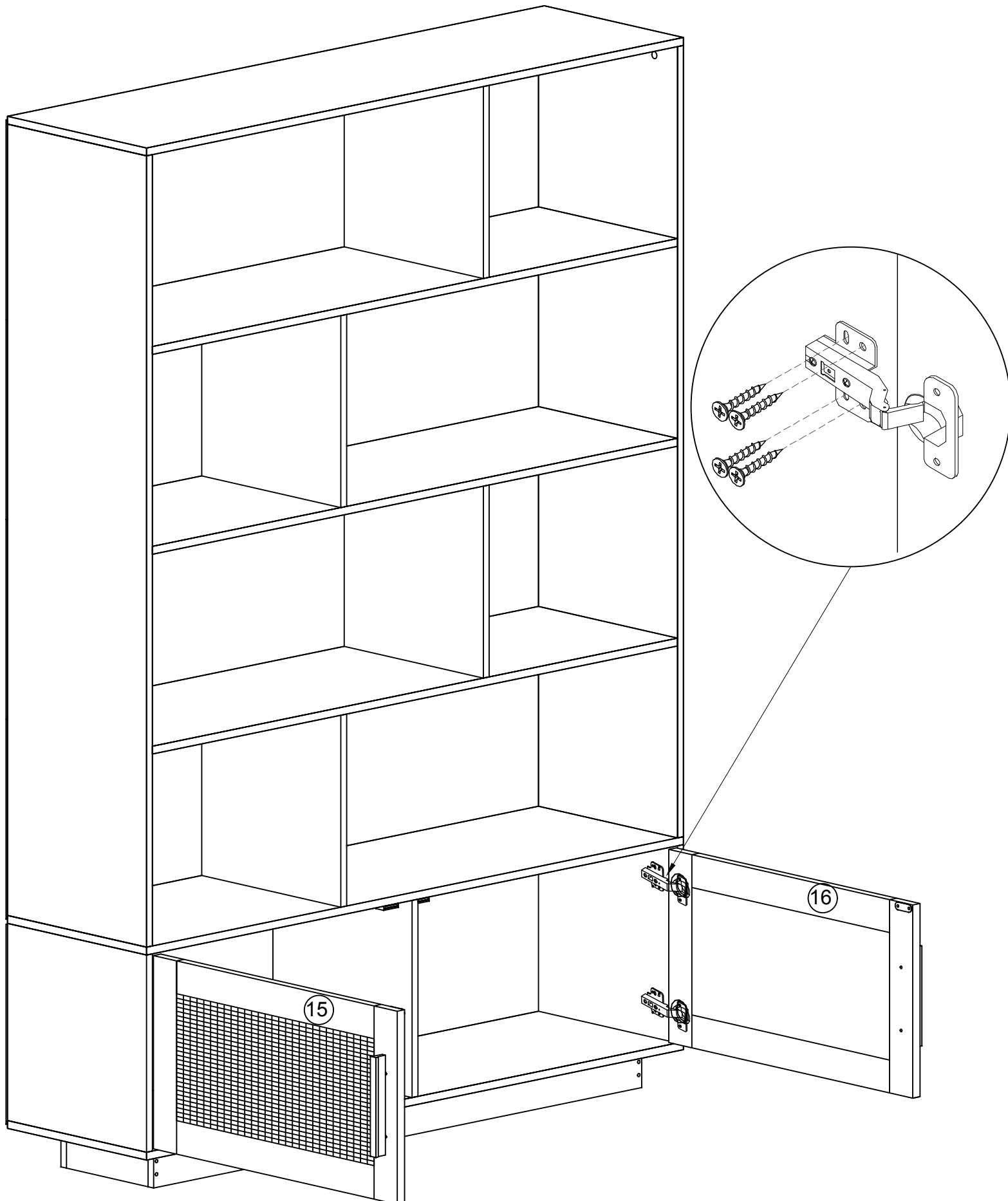

20

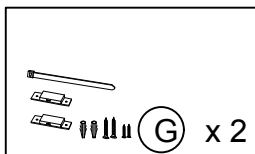

WALL

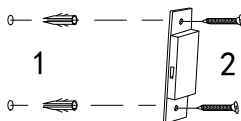

BOARD

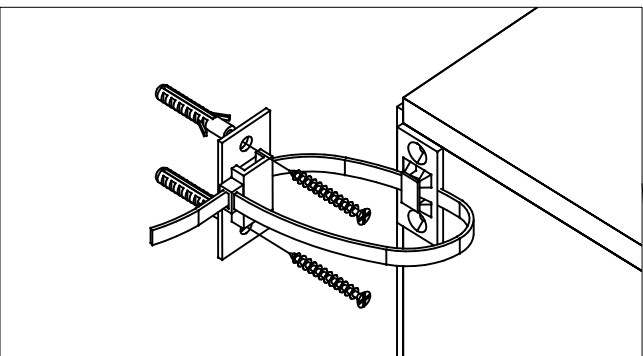
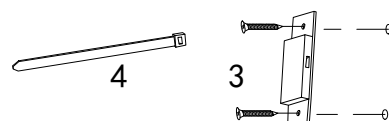

1. Drive the expansion screw into the appropriate position on the wall

2. Use long screws to install one of the plastic buckle seats in the appropriate position on the wall.

3. Use short screws to install the other plastic buckle in the appropriate position on the cabinet.

4. Push the cable tie through the two plastic buckle seats and pull tight. As shown in the figure.

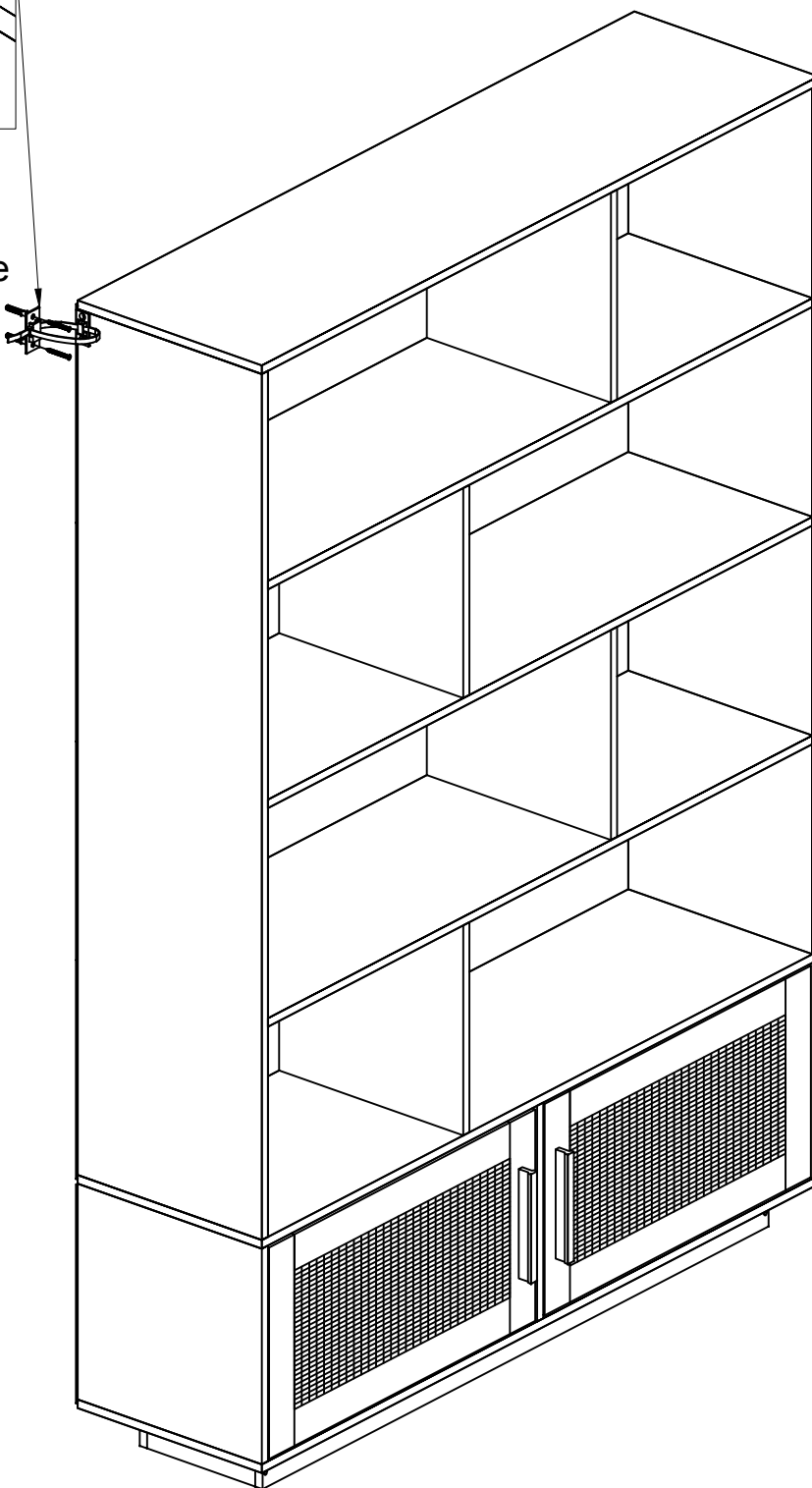

21

# Finished assembly

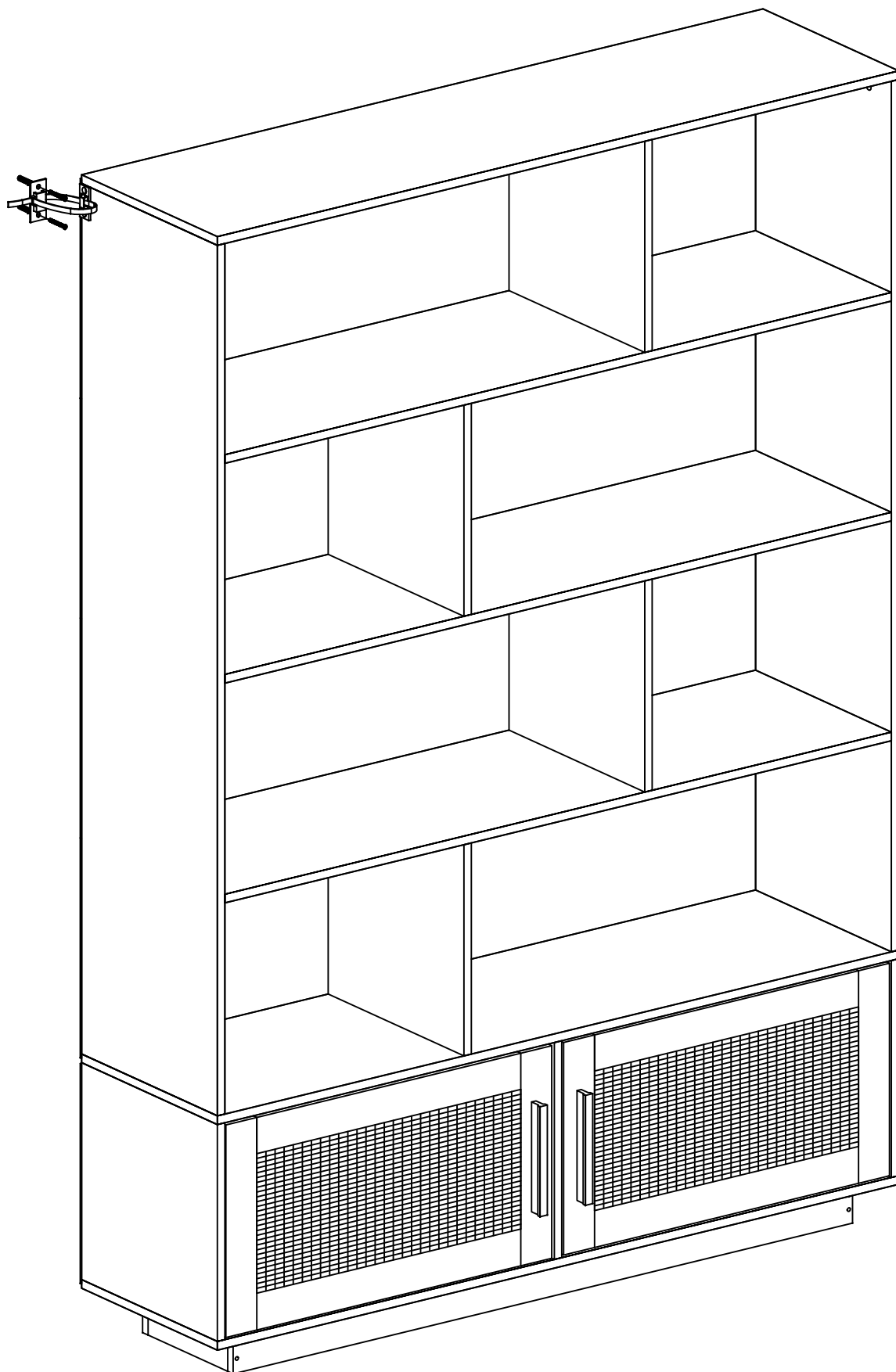

Dear customer, thank you for purchasing our customers with high quality products!

products! We are proud to present



If you have any product quality or use problems, please contact our customer service by email, we will ensure your satisfaction.



If you are satisfied with our products, please share your amazing experience with us and other customers! It would be our honor to hear from you!



**Customer Service Team**