

# INSTRUCTION MANUAL

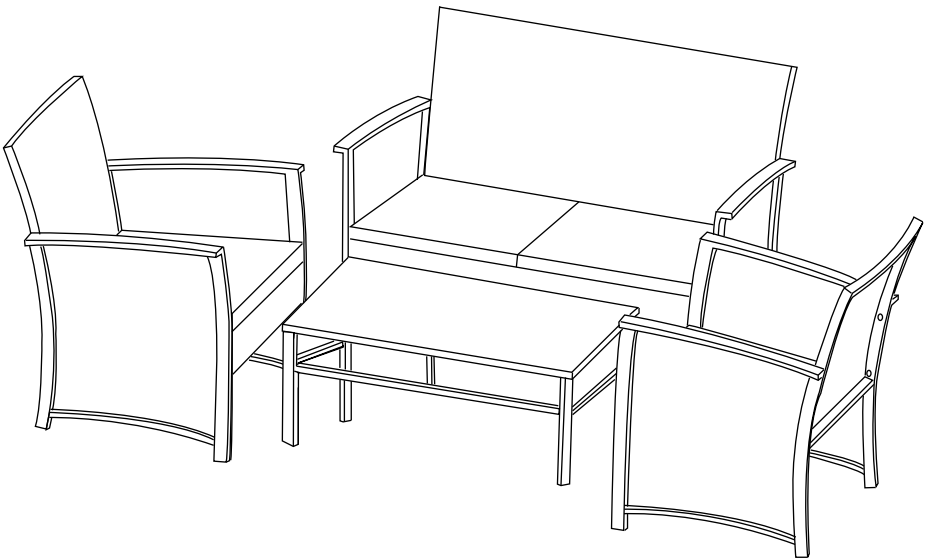

**4 - Piece Woven Rattan Wicker Seating Set**

## ! NOTICE

### Do not overtighten screws. (Insert all screws before tighten screws.)

- Please do not exceed the weight limitations of this item.
- Do not stand on or use any part of this item as a step ladder.
- Firmly secure all bolts, screws and nuts before use.
- Reconfirm that all bolts, screws, and nuts are secure every 90 days.
- Do not use or store this item in the proximity of open flame or flammable/combustible chemicals.
- Be aware that some parts are heavy and have sharp edges.

## TOOLS REQUIRED



ALLEN WRENCH  
(PROVIDED)



CHAIR  
330 LBS  
CAPACITY



LOVESEAT  
660 LBS  
CAPACITY



TABLE  
110 LBS  
CAPACITY



1 PERSON  
ASSEMBLY



UP TO 60 MIN.  
ASSEMBLY

## HARDWARE

1

M6 x 30mm  
BOLT



39 PCS

2

M6 WASHER



39 PCS

3

ALLEN  
WRENCH



1 PC

## PARTS

A

CHAIR RIGHT SIDE



3 PCS

B

CHAIR LEFT SIDE

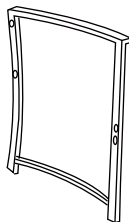

3 PCS

C

LOVESEAT TOP

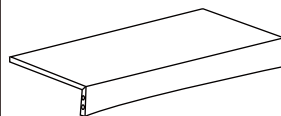

1 PC

## PARTS

**D**

LOVESEAT BACKREST

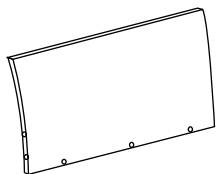

1 PC

**E**

SEAT CUSHION

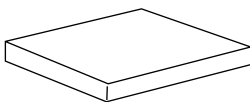

4 PCS

**F**

CHAIR SEAT

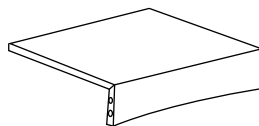

2 PCS

**G**

CHAIR BACKREST

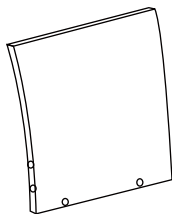

2 PCS

**H**

TABLE LEG

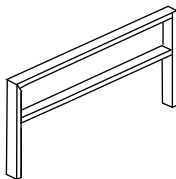

2 PCS

**I**

TABLE SIDE

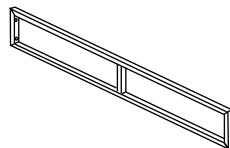

2 PCS

**J**

TABLE TOP

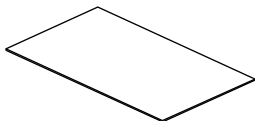

1 PC

## PRODUCT ASSEMBLY - CHAIR

1

Attach the part F Chair Seat to part G Chair Backrest with 2 PCS of part 1 bolt and part 2 washer.

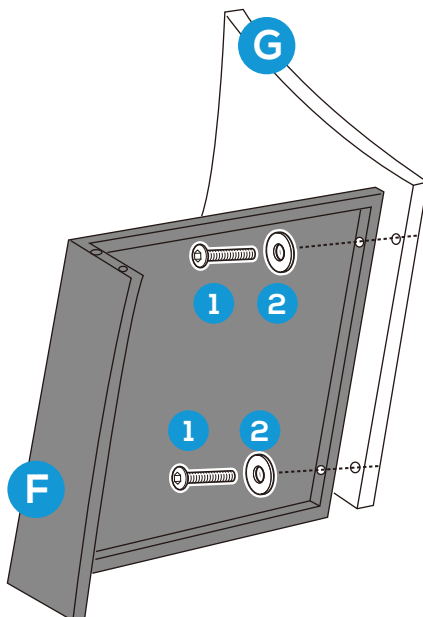

2

Attach the assembled part ( F + G ) to part B Chair Left Side with 4 PCS of part 1 bolt and part 3 washer.

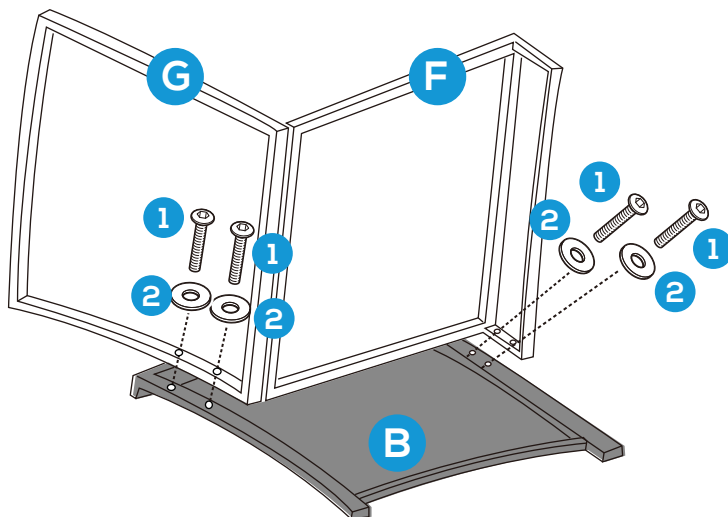

## PRODUCT ASSEMBLY - CHAIR

3

Attach part A Chair Right Side to part C Chair Seat and part D Seat Backrest with 4 PCS of part 1 bolt and part 2 washer.

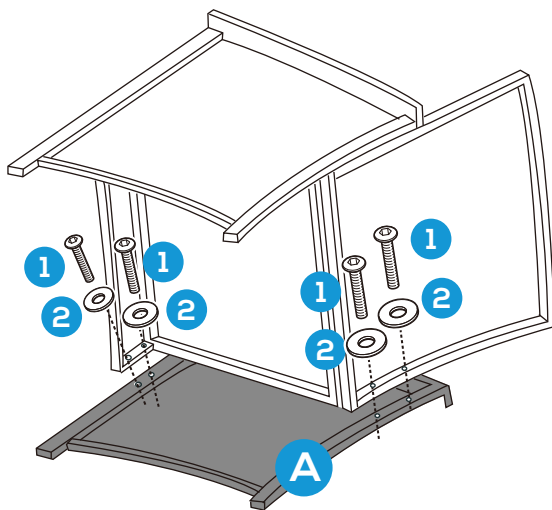

4

Place part E Seast Cushion into the seat to finish the assembly.  
Do the same to assemble the other chair.

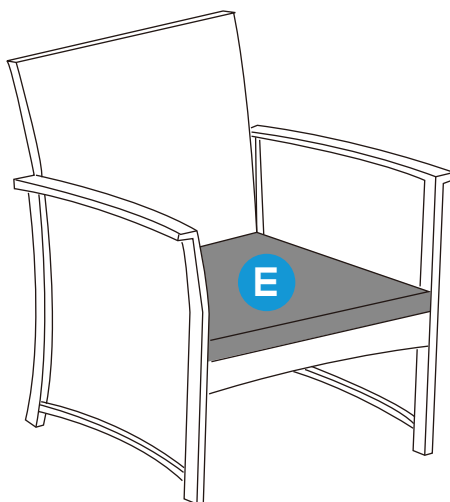

## PRODUCT ASSEMBLY - LOVESEAT

1

Attach the part C Chair Seat to part D Seat Backrest with 2 PCS of part 1 bolt and part 2 washer.

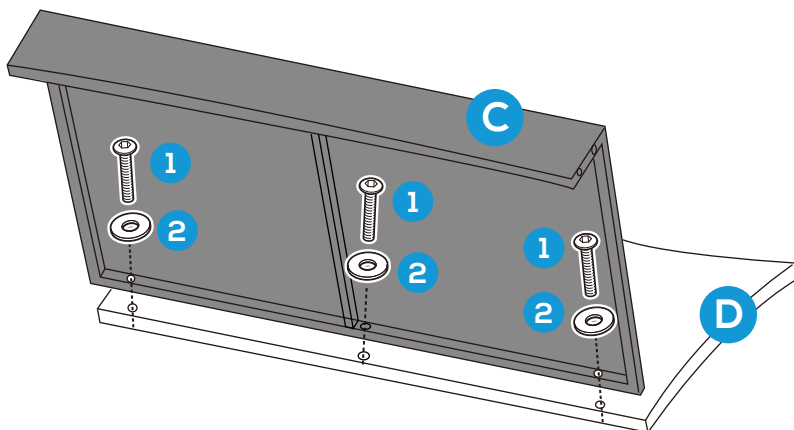

2

Attach the assembled part (C+D) to part B Chair Left Side with 4 PCS of part 1 bolt and part 2 washer.

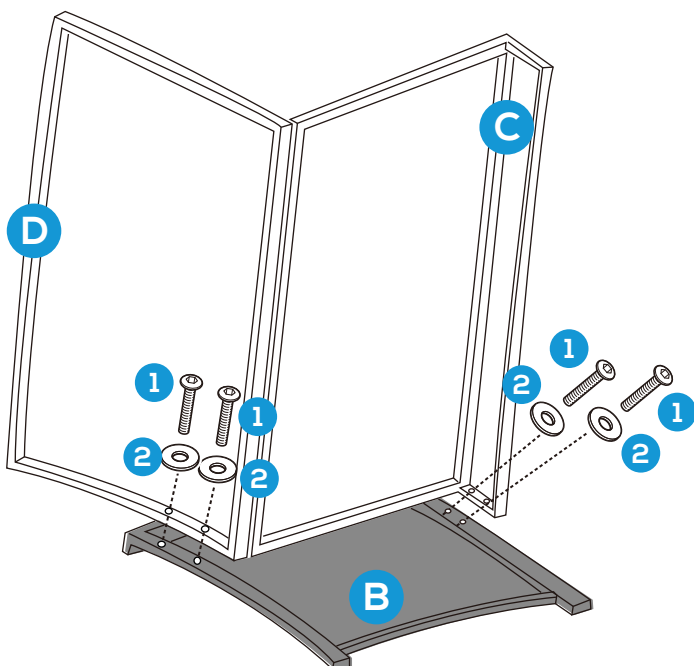

## PRODUCT ASSEMBLY - LOVESEAT

3

Attach part A Chair Right Side to part C Chair Seat and part D Seat Backrest with 4 PCS of part 1 bolt and part 2 washer.

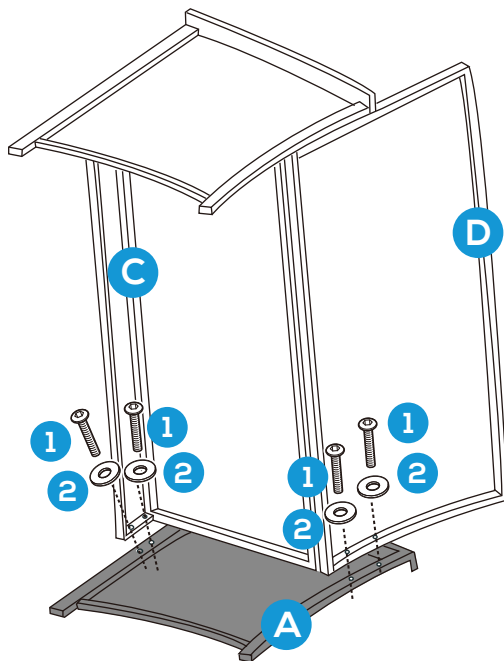

4

Place part E Seast Cushion into the seat to finish the assembly.

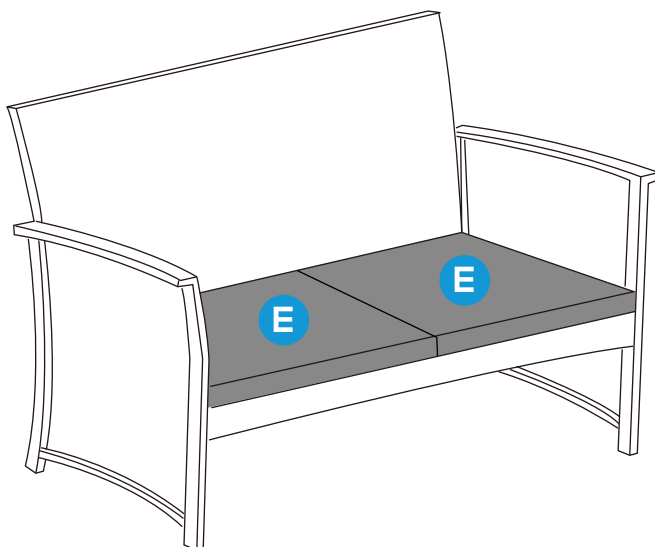

## PRODUCT ASSEMBLY - COFFEE TABLE

1

Attach part I Table Side to part H Table Leg with 8 PCS of part 1 bolt and part 2 washer.

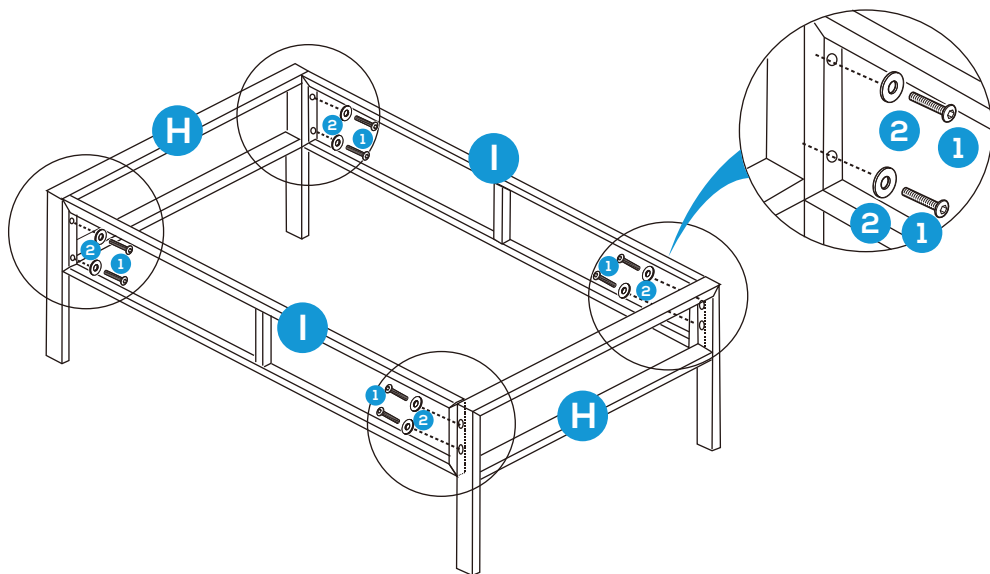

2

Put part J Table Top onto the frame to finish the assembly.

