

## 6. Lids

To each lid fit a lid front board using 2 x 35mm screws. Screw through the front board into the lid rails. Position the lids between the side panels as shown. Align the predrilled bolt holes and insert a bolt. Secure each bolt with a washer and a nut. Do not over tighten the nuts. Attach two chains to the inside of each lid using 1 x 15 mm screw per chain. Position the chains so that they can be looped round the handles of the bin and hooked back on the chain. Attach the lid stays using 1 x 40mm screws per stay as shown.

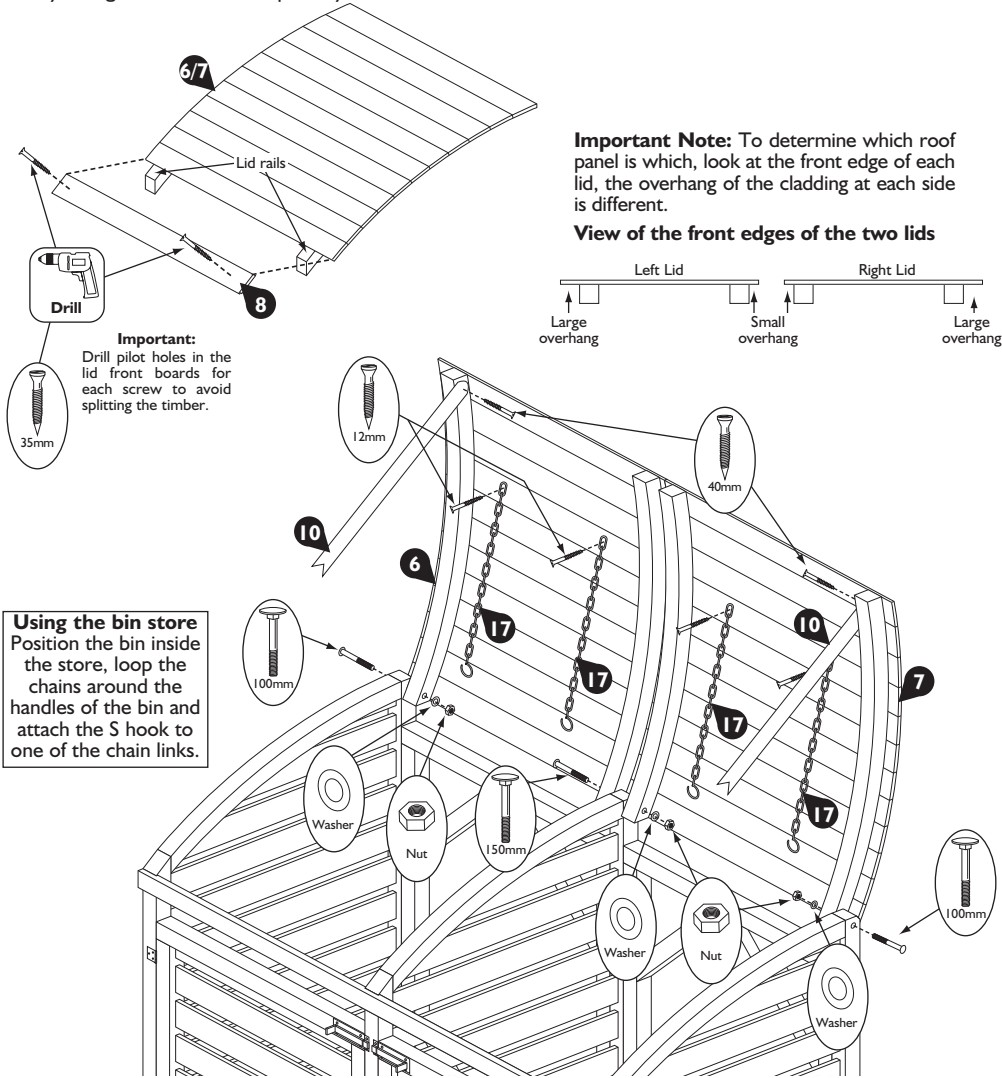

# Double Bin Store

# English

## Assembly Instructions

### Before assembly

- We recommend that time is taken to read the instructions before starting assembly, then follow the easy step by step guide. The instruction sheet is only a guide to the assembly. Certain items may not be shown to scale.
- Check all components prior to assembly
- This product should be assembled by no less than two people.
- Never attempt to erect the assembly in high winds.
- Drill pilot holes for each screw



### Recommended tools for assembly

- Power drill/screwdriver
- Cross head screwdriver bit
- 3mm drill bit
- 13mm spanner

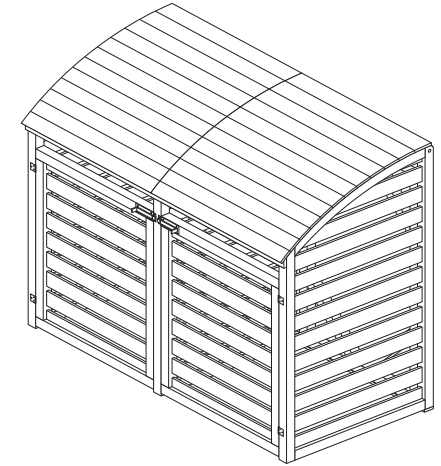

treated wood is a treated article that incorporates biocidal products: cop-per hydroxide carbonate/II/ and boric acid. They protect wood against fungal decay /rot/ and insect attack. Keep away from food, drink and animal feeding stuffs. Avoid breathing dust when cutting treated wood.

No.	Components	Qty.
1	Base plates	4
2	Side panel	2
3	Centre panel	1
4	Back panel	2
5	Door	2
6	Left lid	1
7	Right lid	1
8	Lid front board	2
9	Front rail	2
10	Lid stay	2

No.	Fixing kit	Qty.
11	Hinges	4
12	Slide bolt	2
13	150mm bolt	1
14	100mm bolt	2
15	Nuts	3
16	Washers	3
17	Chain	4
18	60mm screws	12
19	40mm screws	16
20	35mm screws	4
21	30mm screws	36
22	15mm screws	4

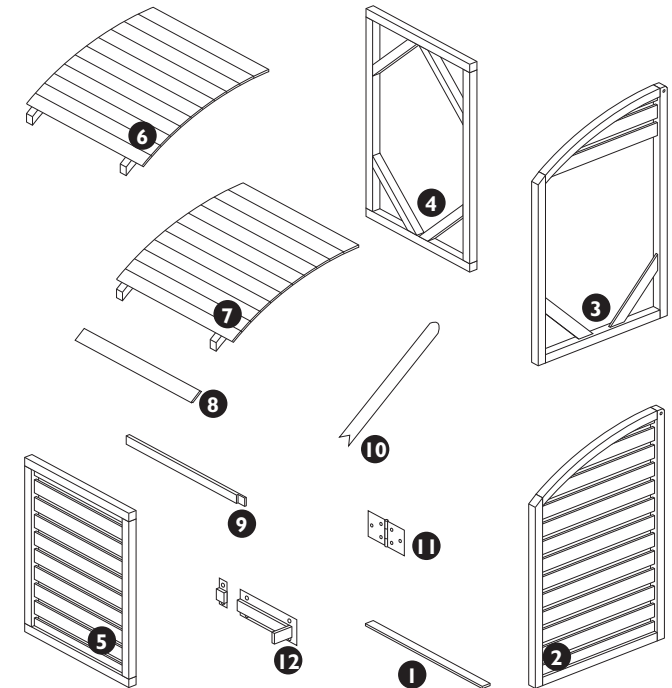

### 1. Side, Centre & back panels

Secure the two side panels, centre panel and two back panels as shown below using 3 x 60mm screws for each join. Ensure all panels are level along the bottom edge.

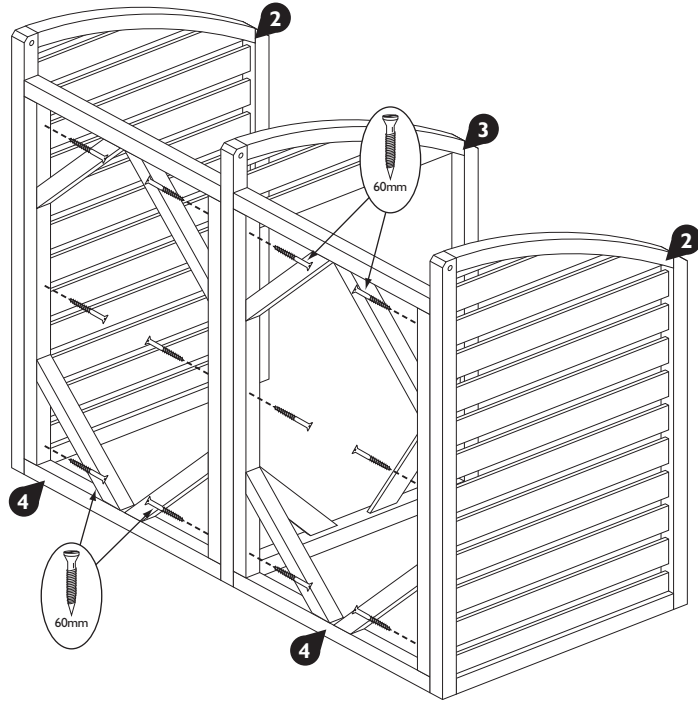

### 2. Base plates

Attach the four base plates using 2 x 40mm screws per plate. When attaching the plates, ensure that the end of each plate is flush with the side panels.

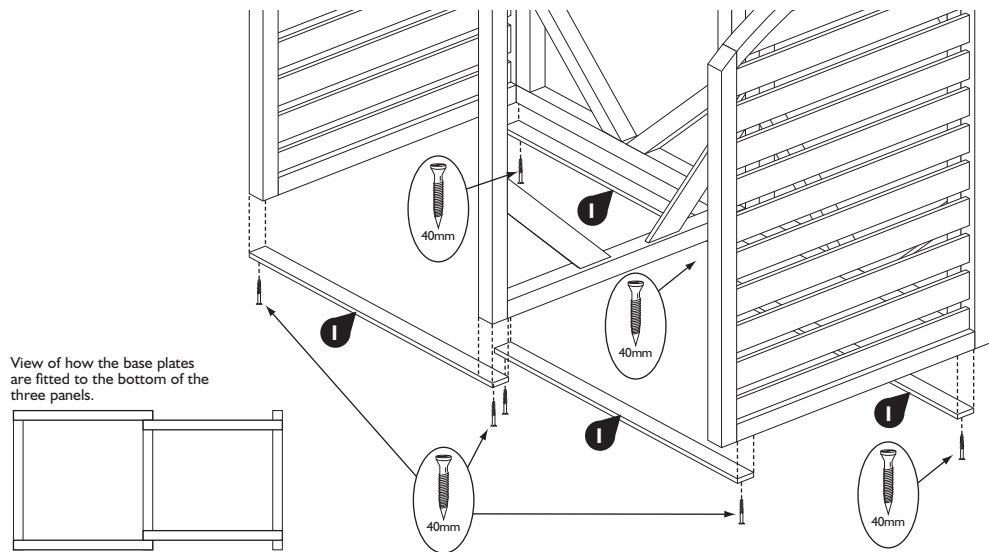

### 3. Front rails

Secure the two front rails to the top of the front face of the uprights as shown using 6x40mm screws.

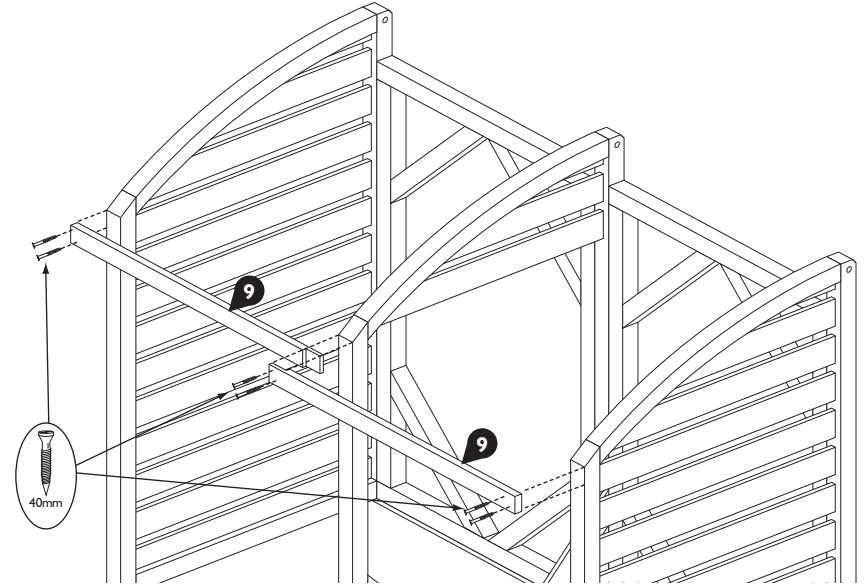

### 4. Doors

Attach the hinges to the frames of the doors as shown below using 3x30mm screws per hinge. Position the doors between the side panels leaving a small gap between the bottom of the door and the base plate. Secure the hinges to the outer side panels using 3x30mm screws per hinge. For each door position the two parts of the slide bolt as shown below and secure using 6x30mm screws for each bolt set.

