

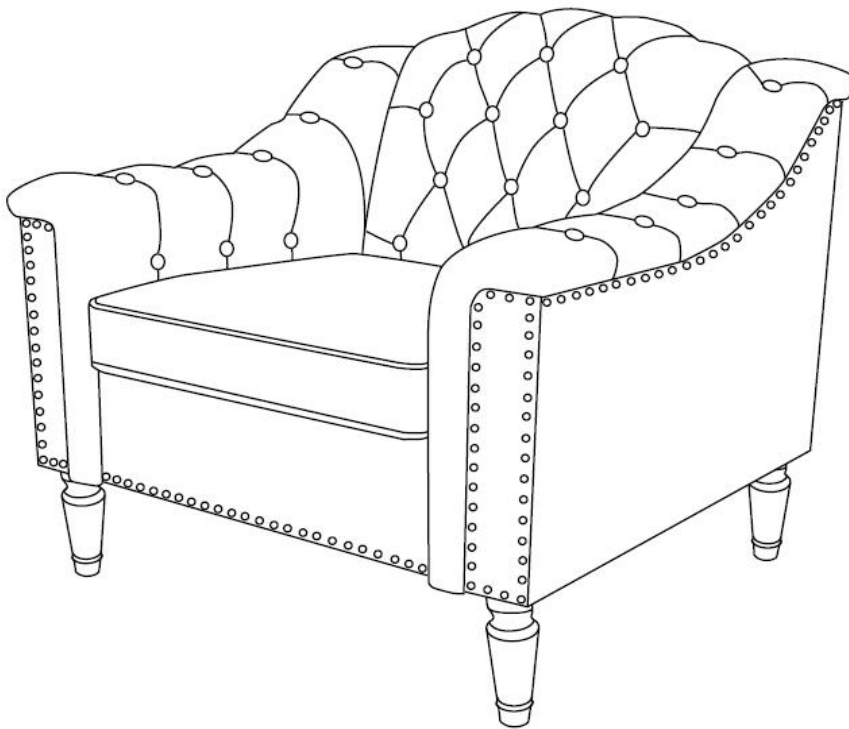





# Assembly Instructions

**Note: Please help to read my instruction before you ready to assemble.**

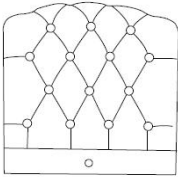
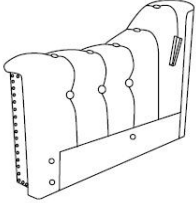
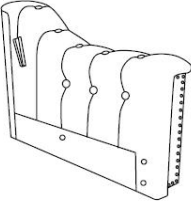



## CHAIR





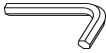



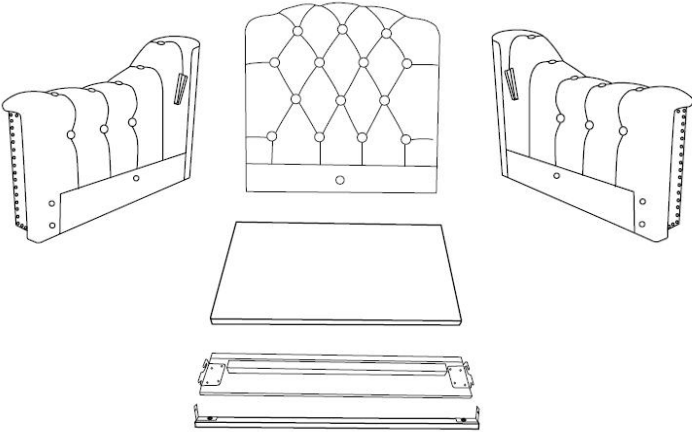
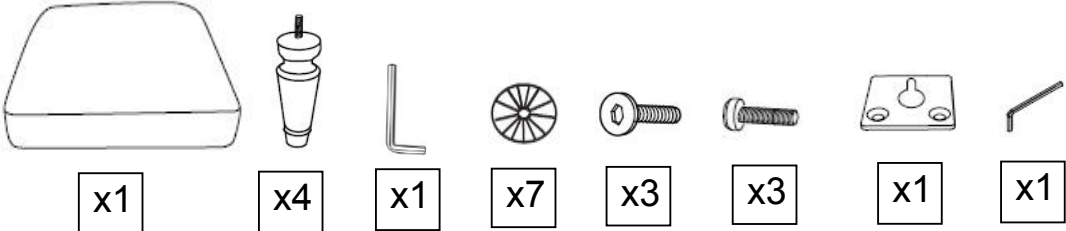

## Part List

Label	Picture	Description	QTY (PCS)
A	 A line drawing of a tufted backrest with a diamond-shaped pattern of buttons and a small circular detail at the bottom center.	Backrest	1
B	 A line drawing of a left armrest with a tufted top and a base with several mounting holes.	Left Armrest	1
C	 A line drawing of a right armrest, similar to the left one but mirrored, with a tufted top and a base with mounting holes.	Right Armrest	1
D	 A line drawing of a rectangular seat cushion with a slightly raised edge and small tabs at the corners.	Seat	1
E	 A line drawing of a long, narrow front rail with a central channel and mounting tabs at both ends.	Front Rail	1
F	 A line drawing of a long, narrow back connecting piece with a central channel and mounting tabs at both ends.	Back Connecting Piece	1
G	 A line drawing of a rectangular seat cushion with a slightly raised edge.	Seat Cushion	1
H	 A line drawing of a single leg, which is a tapered cylindrical shape with a small circular detail at the top.	Leg	4

## Hardware

①		Plastic Washer	7
②		Allen Wrench	1
③		Bolt(M8*25mm)	3
④		Bolt(M6*20mm)	3
⑤		Metal Bracket	1
⑥		Allen Wrench(S4)	1

## Assembly Preparation

All Including:	
	
	<div style="display: flex; justify-content: space-around; align-items: center;"> <div style="text-align: center;"> x1</div> <div style="text-align: center;"> x4</div> <div style="text-align: center;"> x1</div> <div style="text-align: center;"> x7</div> <div style="text-align: center;"> x3</div> <div style="text-align: center;"> x3</div> <div style="text-align: center;"> x1</div> <div style="text-align: center;"> x1</div> </div>

### NOTICE:

- Please read the instruction from cover to cover in detail.Thanks.
- Installed by at least two adults.
- To avoid damaging your furniture , Please don't assemble on flooring or carpet.
- Please assemble on a clean non-marring surface, example for packing foam.
- Saving all packaging until have finished.

## Assembly Steps

### OVERVIEW

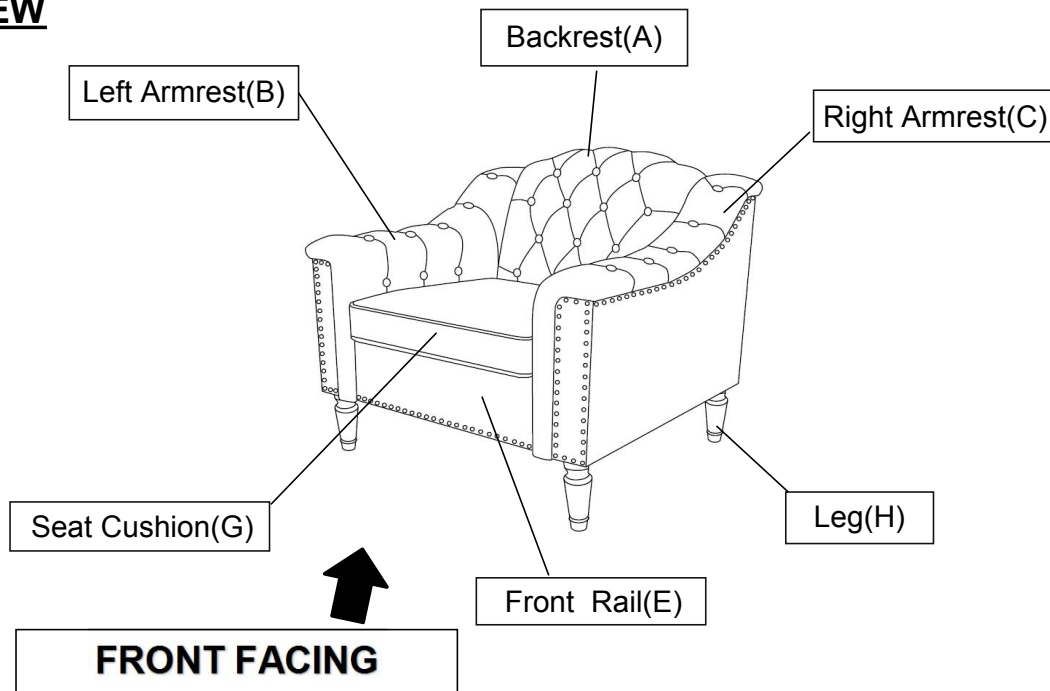

This Chair has multiple parts and may require up to 30 minutes to assemble. To give you an overview of the Chair parts, the above picture is to help you put the various parts into perspective. Please read through the instructions below to familiarise yourself with the parts and steps before assembly.

**Note: It is recommended that you have an adult partner to assist during the entire assembly process.**

### Step 1

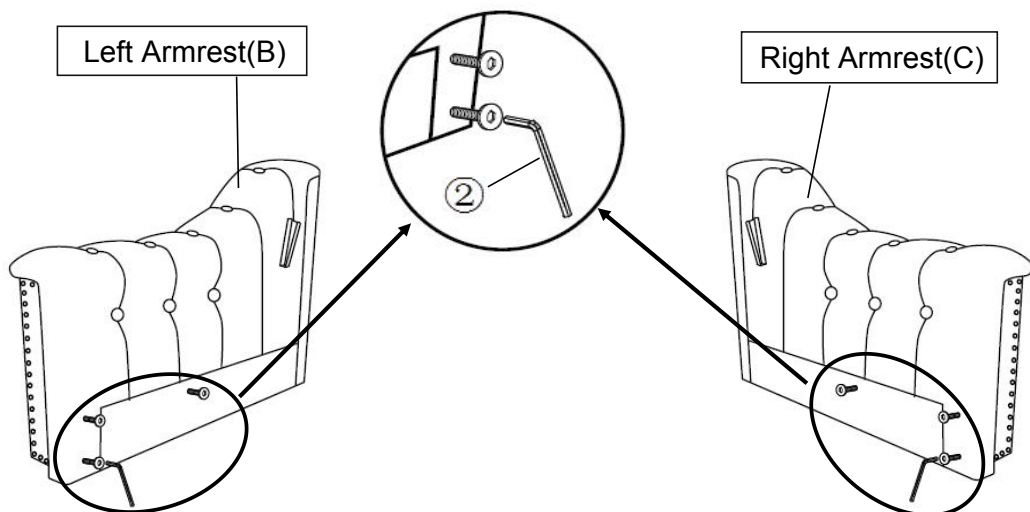

Open the carton and place all the parts on a clean, non-marring surface.

Loosen the 3 bolts in Left Armrest(B) and Right Armrest(C) around half inch by Allen Wrench(②).

**Step 2**

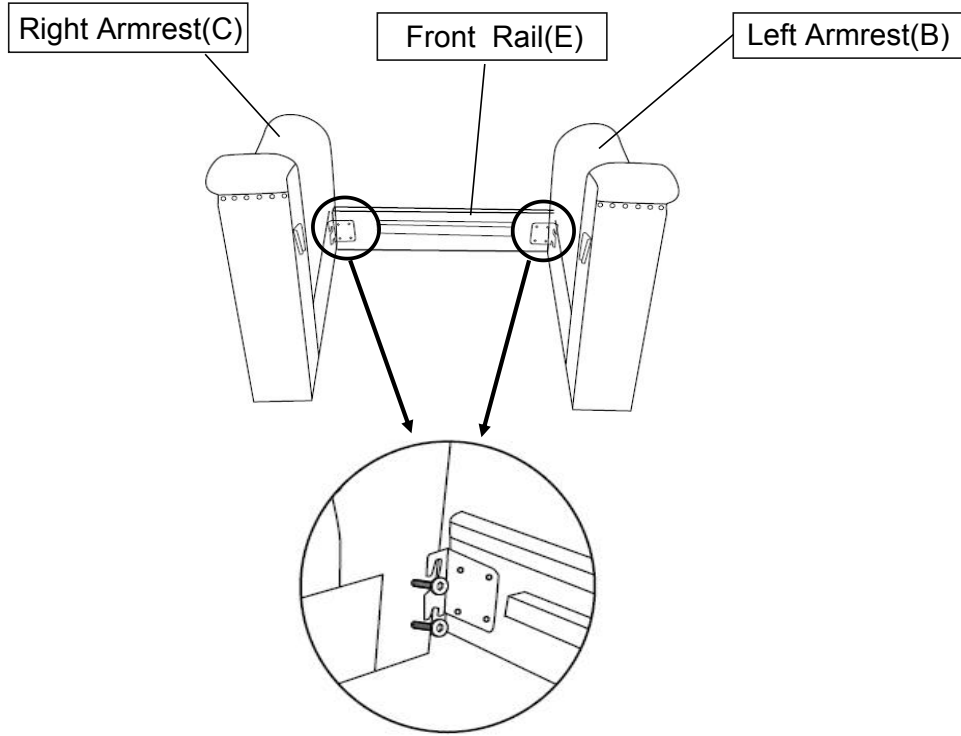

With the assistance of your partner, slide the hook in the end of Front Rail(E) into the bolts on the Left Armrest(B) and Right Armrest(C) as shown in Picture.

**Step 3**

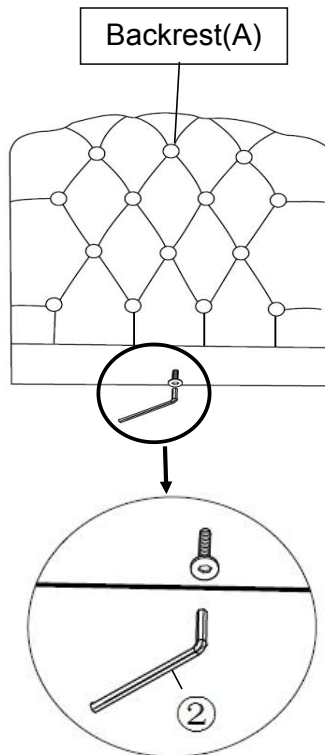

Loosen the bolt in Backrest(A) around half inch by Allen Wrench(②).

#### Step 4

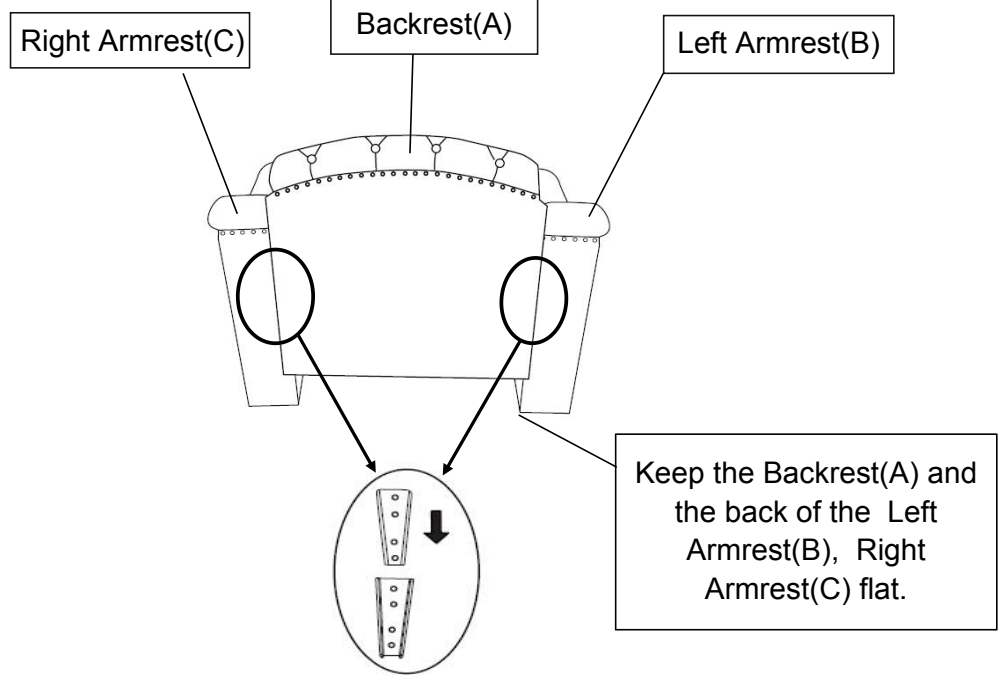

Slide the Tapered Connectors on the Backrest(A) into the Tapered Connectors on the Left Armrest(B) and the Right Armrest(C) as shown in the picture.

**Note: Make sure the Tapered Connectors on Backrest(A) lock into the Tapered Connectors on the Left Armrest(B) and Right Armrest(C).**

**Assistance from an adult partner is necessary for this assembly process.**

**During this assembly process - do exercise caution. You may need to use your hand to press down and or pave away the padded surface to facilitate the 'slip and slide' assembly.**

**Caution: Ensure that your fingers do not get caught or pinched in the assembly process.**

#### Step 5

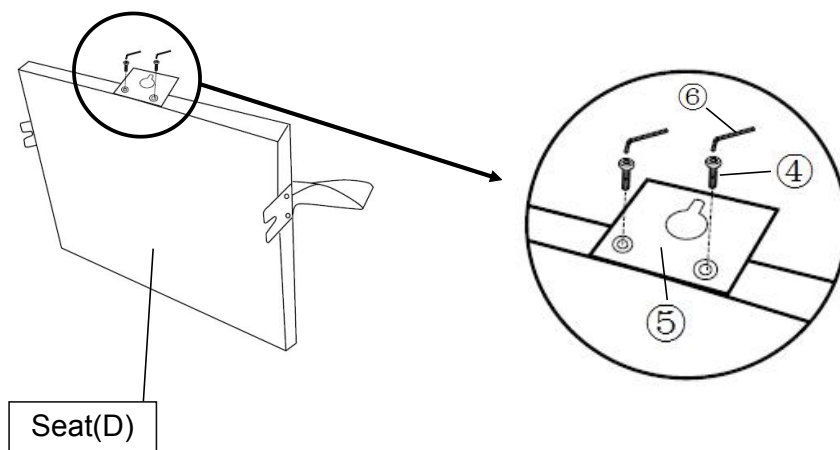

Install the Metal Bracket(5) with Bolt(4),Allen Wrench(6) on the Seat(D).

## Step 6

Step6.1

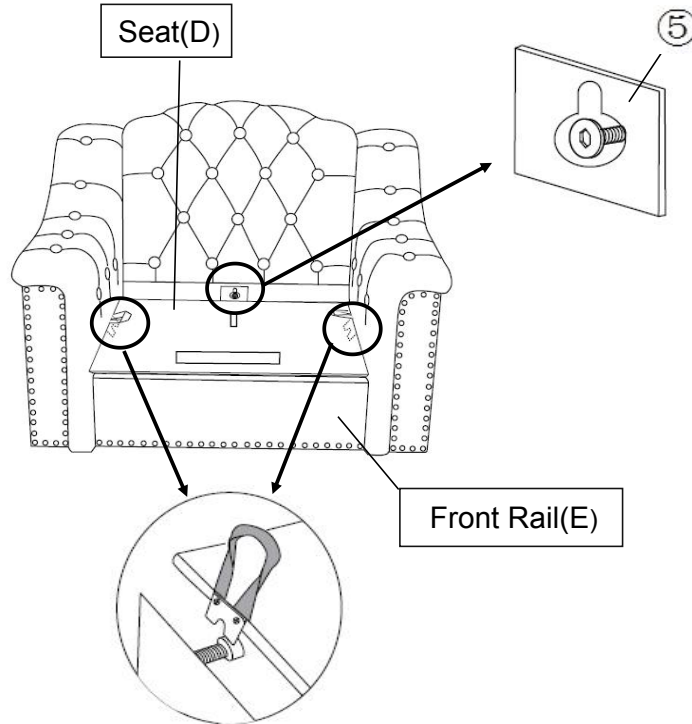

Step6.2

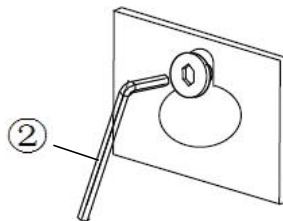

Step 6.1 With the assistance of your partner, lift the rope on the two sides of Seat(D) by hand. Put the Seat(D) on the wood bar of the Front Rail(E) and then slowly place it down as shown above.  
**Note: The u-shaped iron sheet need clamped to the bolt. the Bolt in the Backrest(A) need insert into the Metal Bracket(5) on Seat(D).**  
Step 6.2 Tighten the Bolt by using Allen Wrench(2).

### Step 7

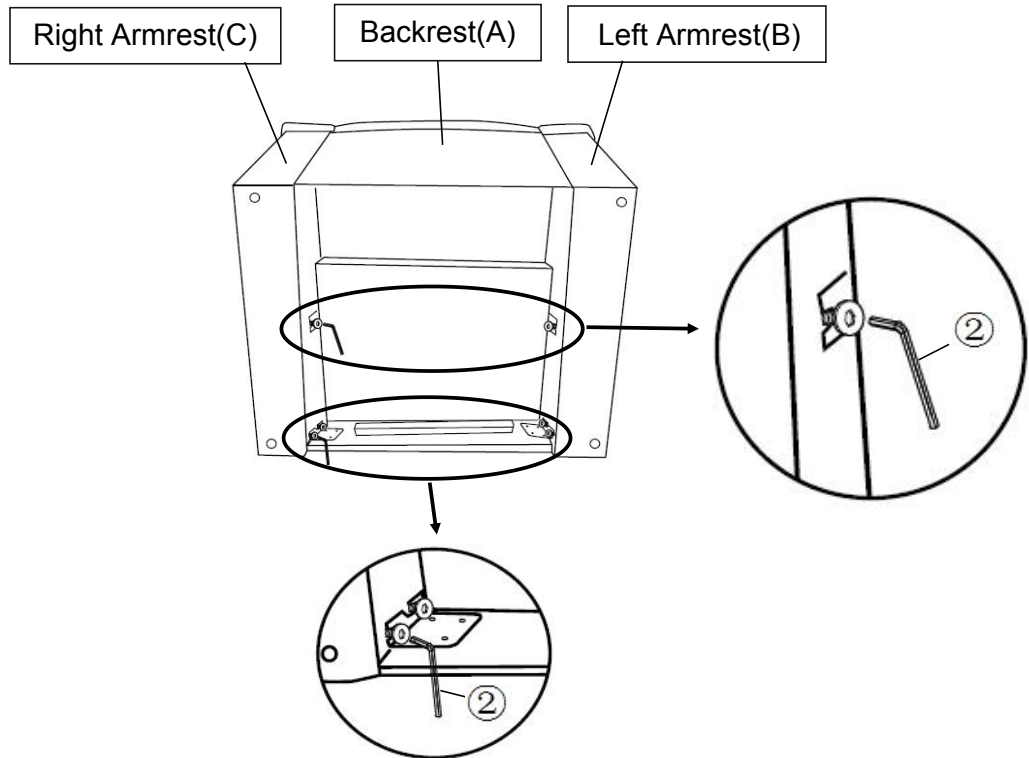

Tilt and lay the Chair bottom up on a flat surface.

Tighten the Bolts in the Left Armrest(B) and Right Armrest(C) by Allen Wrench(2) as pictured above.

### Step 8

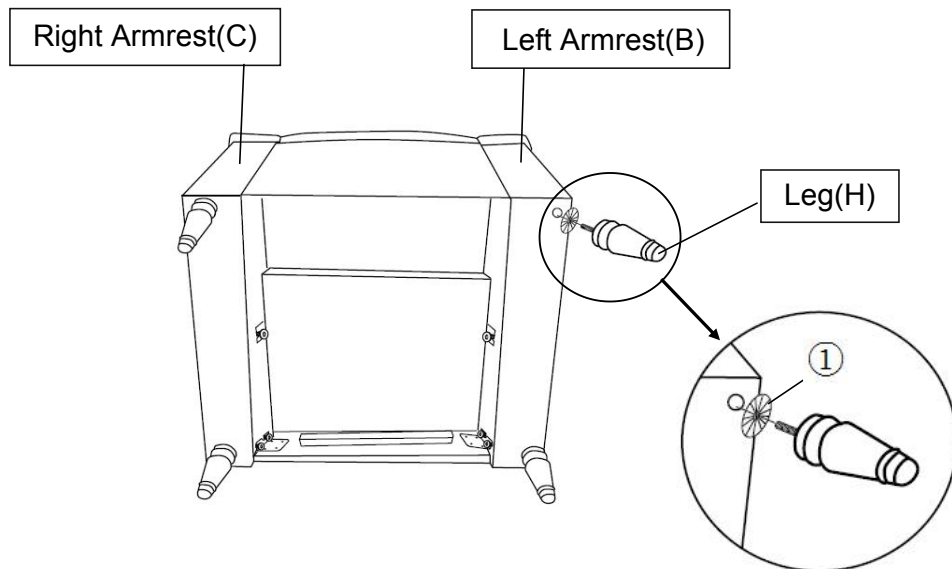

Install the Leg(H) at the bottom of Left Armrest (B) and Right Armrest(C) by placing Plastic Washer(1) on the threaded stem.

Then insert threaded stem into the threaded mounting position at the bottom of Left Armrest(B) and Right Armrest(C). Tighten by turning the Leg clockwise.

**Note: The use of Plastic Washer(1) are OPTIONAL and are especially useful to help alleviate slight wobbles. Some Legs may need more than one whilst some legs may not need any.**

Step 9

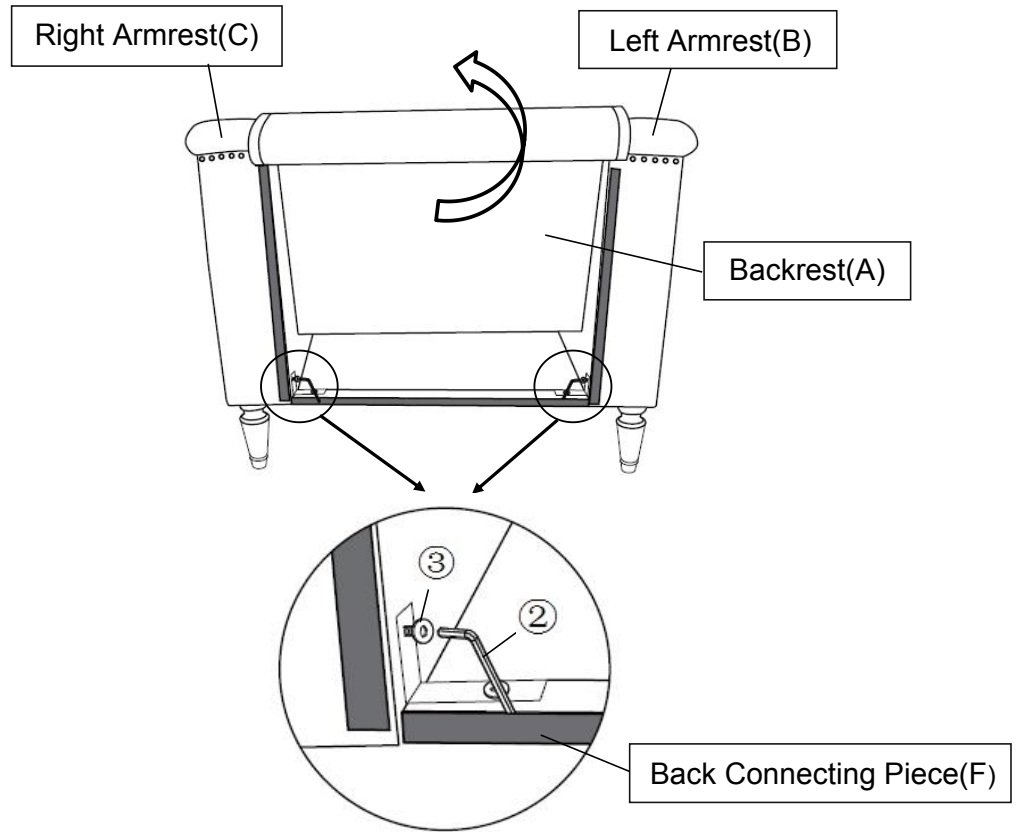

Position the Chair right side up, lift the fabric cover up on the Backrest(A) first, then install the Back Connecting Piece(F) between the bottom of Left Armrest(B) and Right Armrest(C) by using Bolt(③) with Allen Wrench(②) turning clockwise until tight.

**Notice: You have to pay attention to the magic tape of Back Connecting Piece(F) on this step.**

Step 10

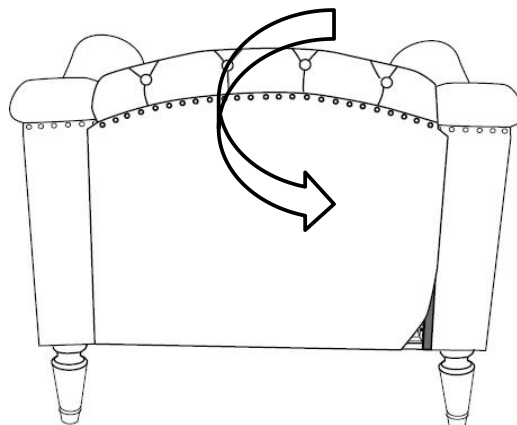

Stick the magic tape back on fabric cover.

Step 11

Seat Cushion(G)

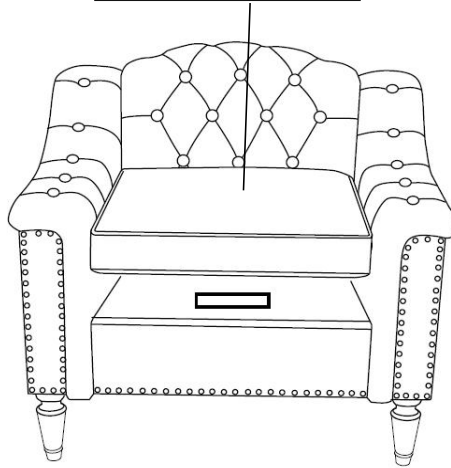

Put the Seat Cushions(G) on the Chair.

Step 12

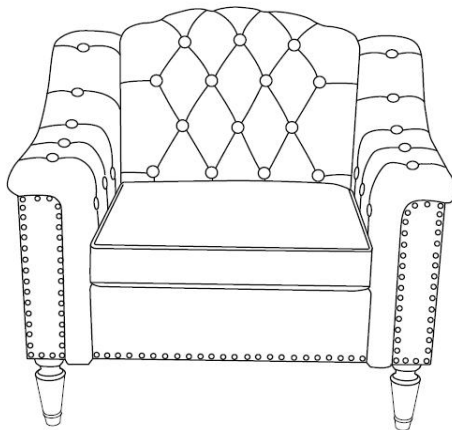

Your Chair is ready for use.  
This Chair can only be used on a flat, level surface.