

ASSEMBLY INSTRUCTION

ITEM NO.:D2740.D2741.D2742-R And-O

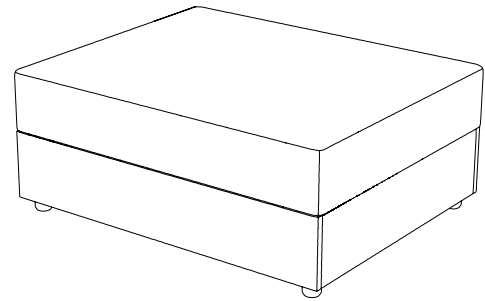

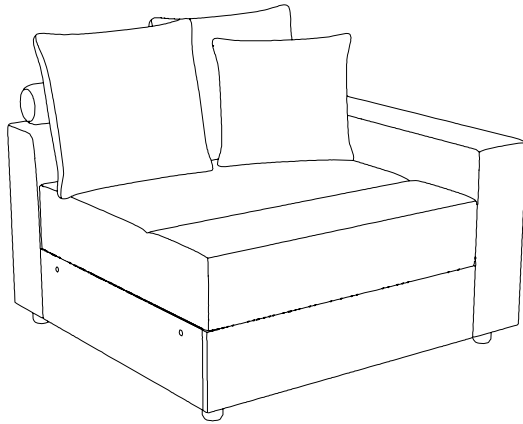
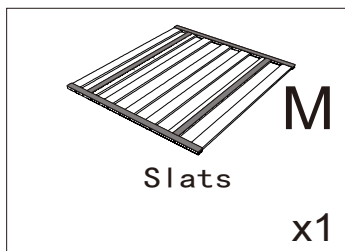
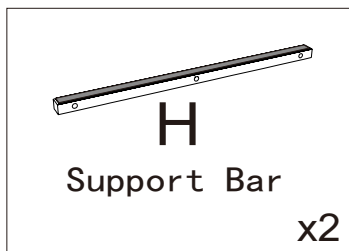
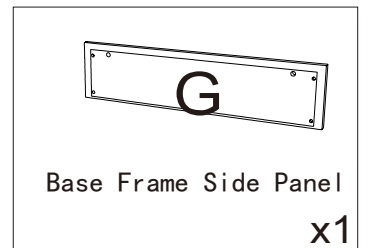
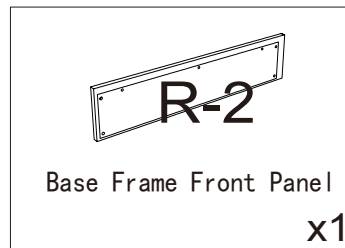
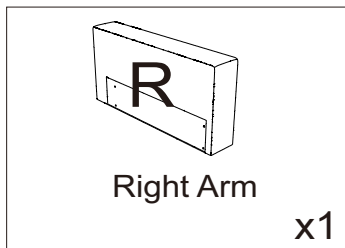
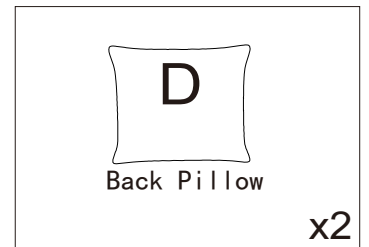
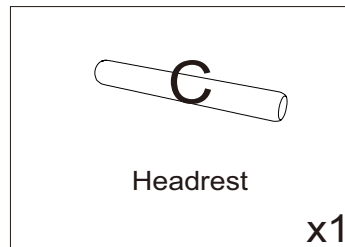
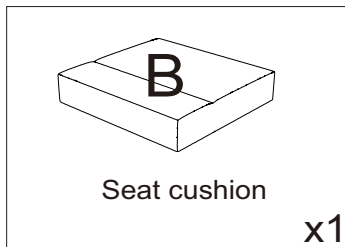
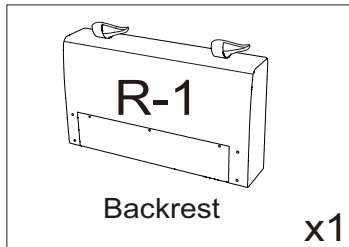

PARTS LIST -R

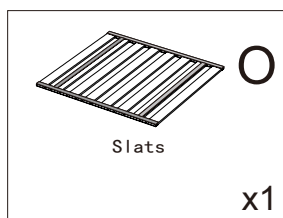
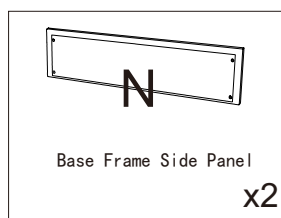
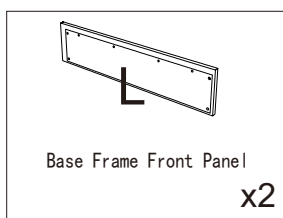
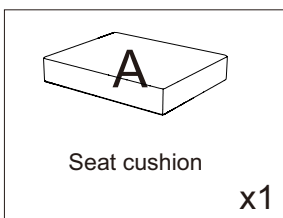

PARTS LIST -O

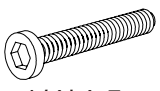

HARDWARE LIST

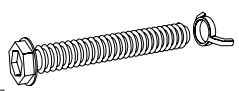
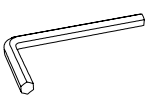
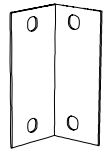
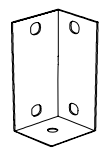
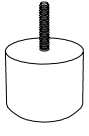
1  1/4*1.8cm x32	2  1/4*4.5cm x14	3  18mm x14	4  1/16*6cm x2
5  40mm*100mm x1	6  x3	7  x5	8  x8

BEFORE ASSEMBLY

Open up Velcro of Non-Woven Fabric cover on the bottom to remove hardware, legs and parts.

1. Please open the black woven fabric with Velcro closure on the bottom of the frame then cut off the black straps before removing the parts for assembly.

2. After removing the cushion from the compress bag, please allow air to flow through the cushion for few days. You can try to fluff cushion by push in and push out on all four sides of the cushion. Hitting the top/front of the cushion with your hand to fluff them after installation.

3. Please allow at least 24 hours for the cushions to recover to its natural state after removing from the package.

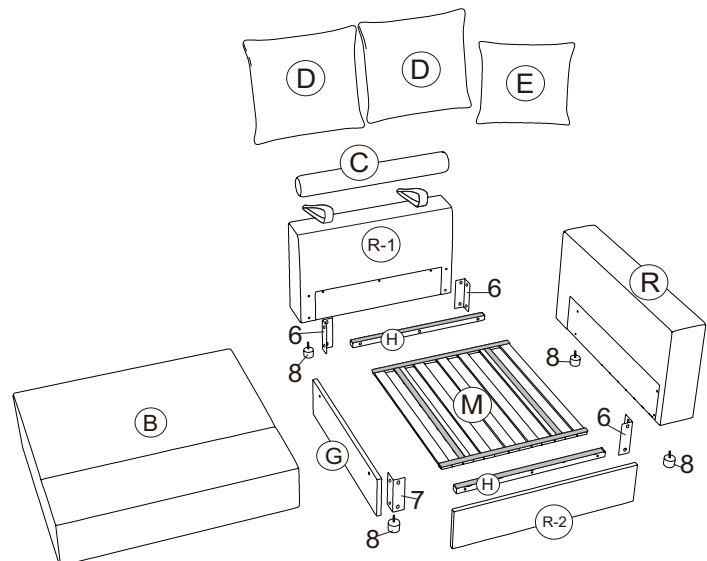
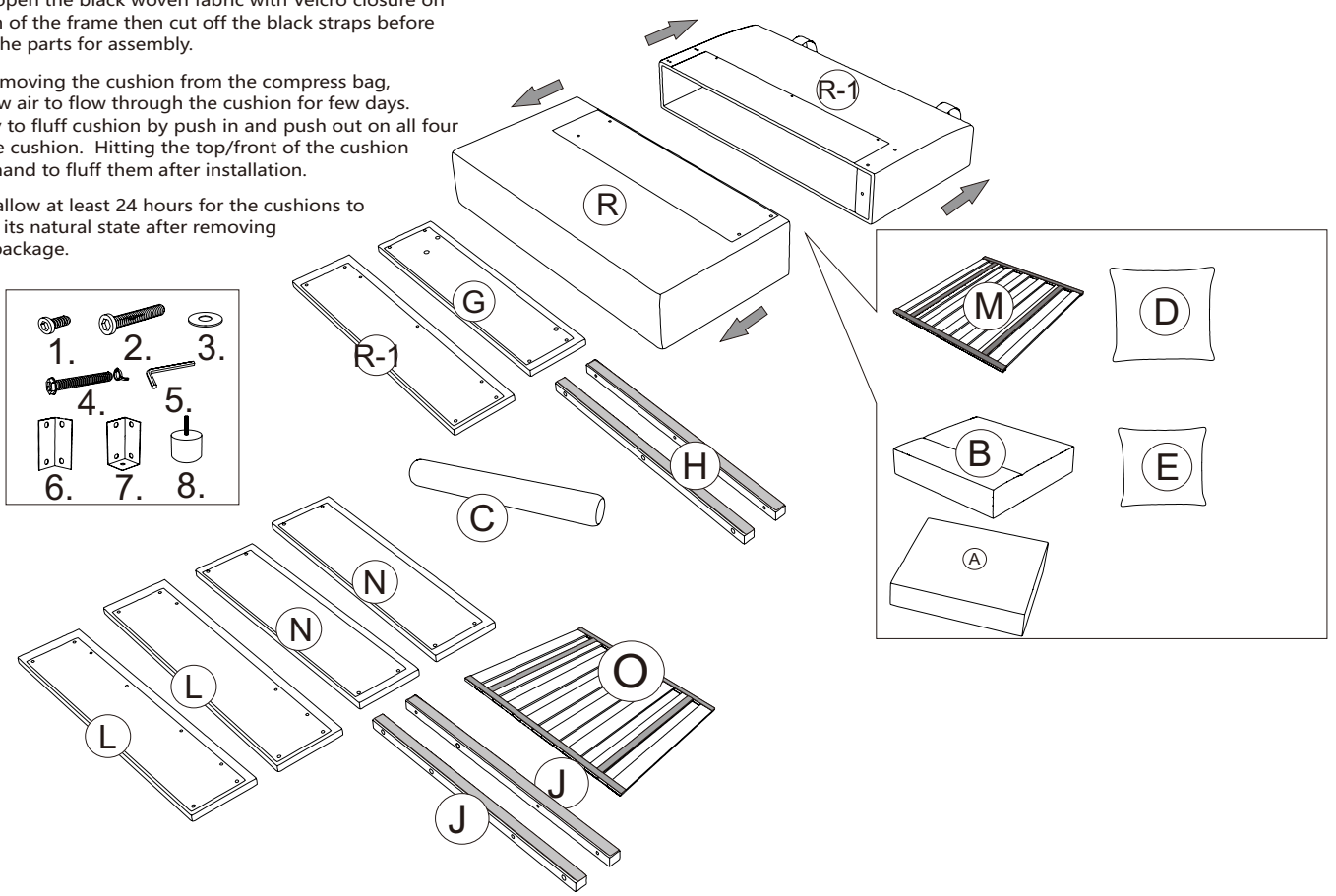

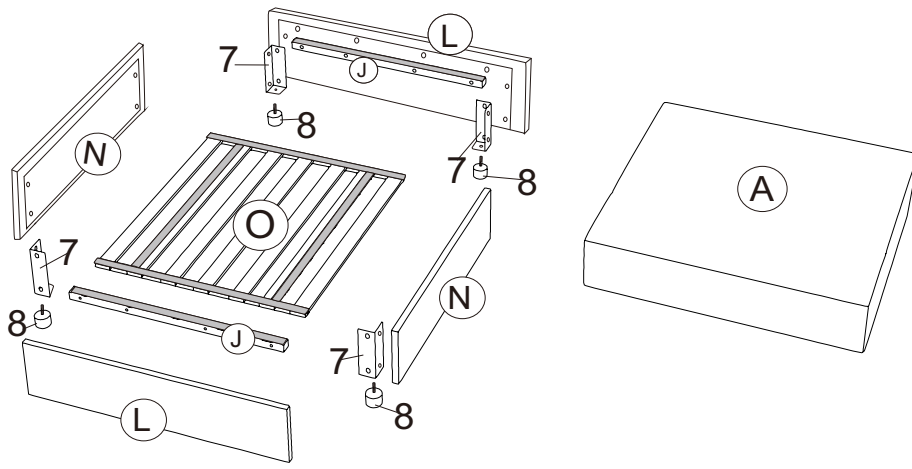

SOFA ASSEMBLY INSTRUCTION

Step1

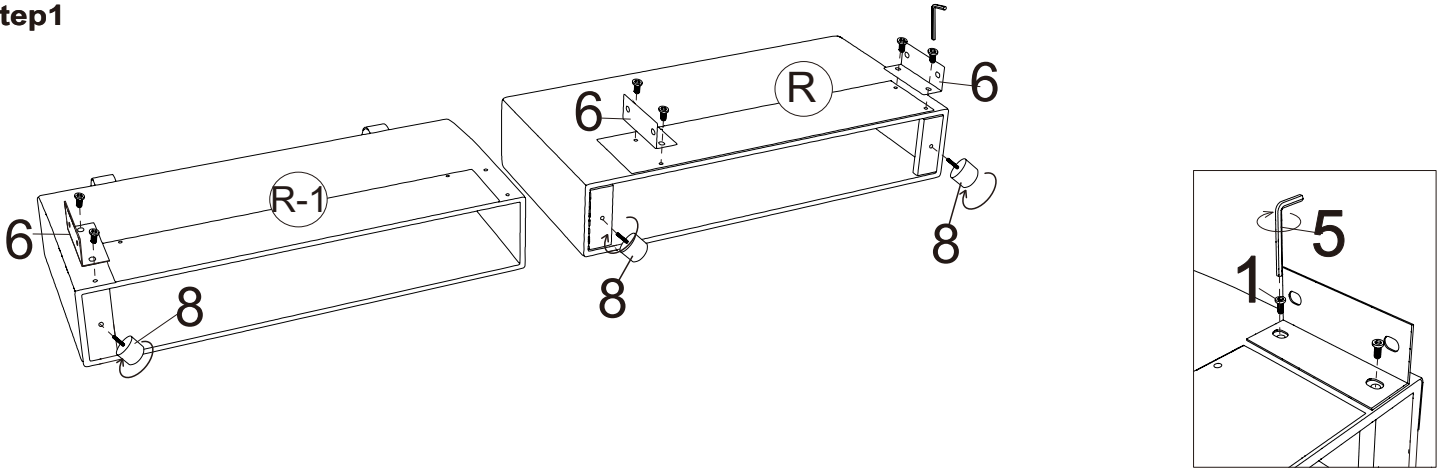

Step2

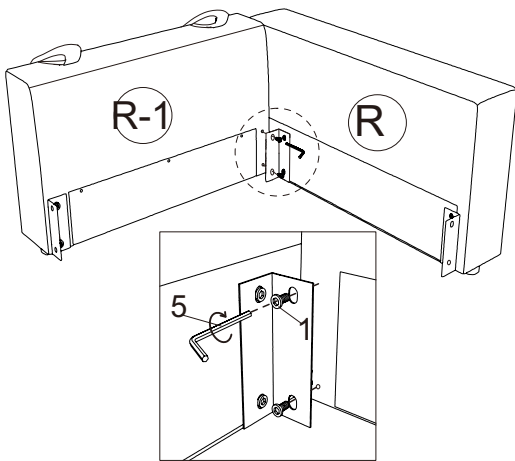

Step3

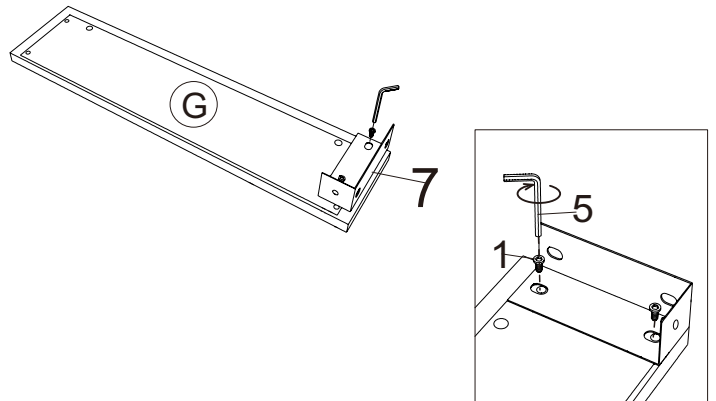

Step4

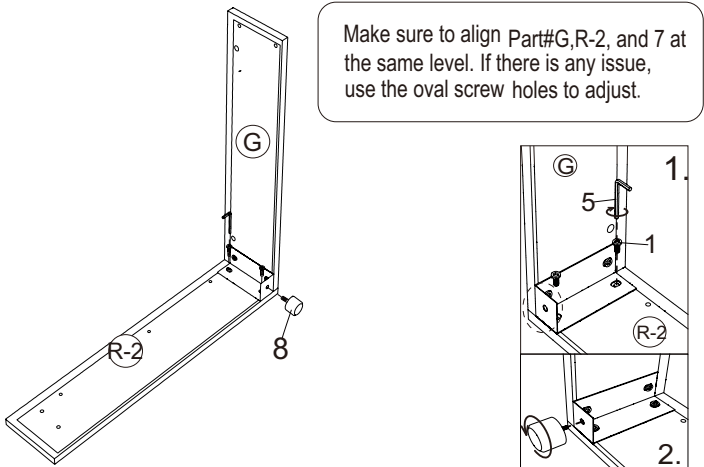

Step5

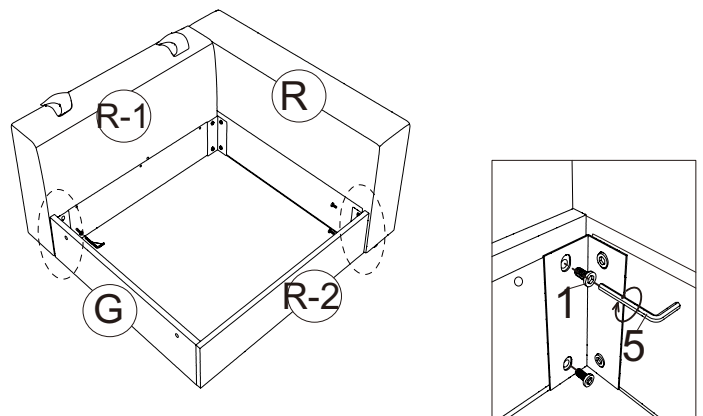

Step6

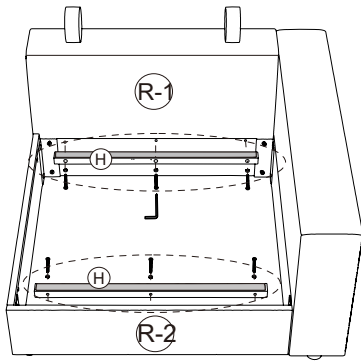

Face the Velcro upward.

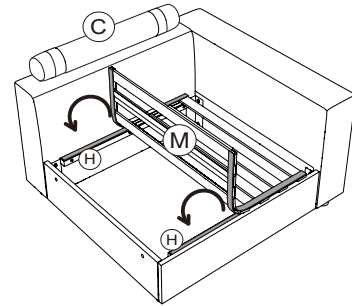
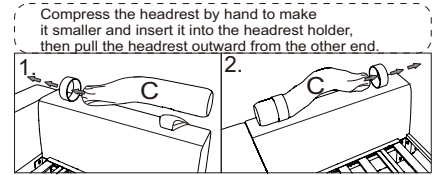

Step7

Face the Velcro upward.

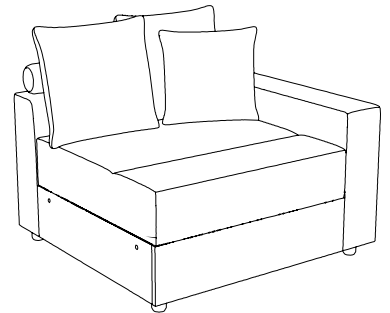
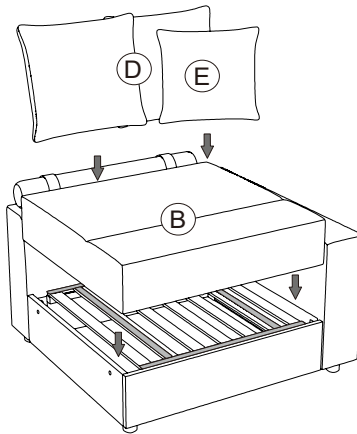
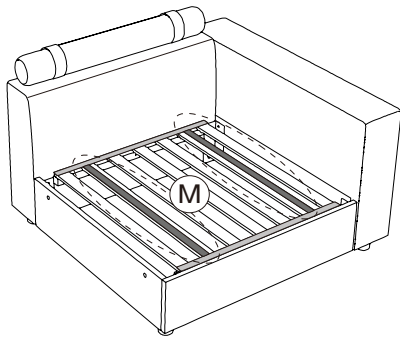

Step1

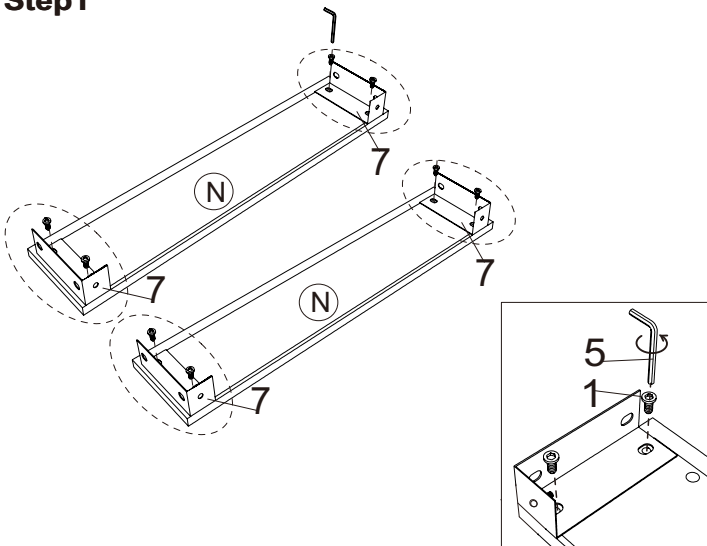

Step2

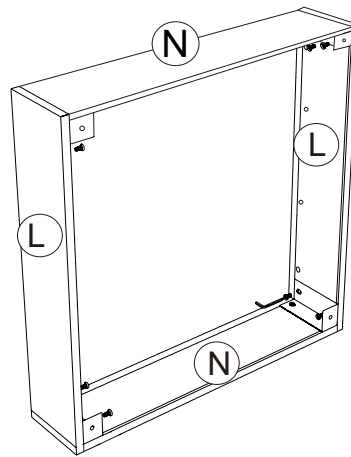

Make sure to align Part#N,L ,and 7 at the same level. If there is any issue, use the oval screw holes to adjust.

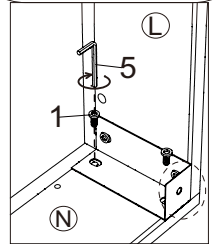

Step3

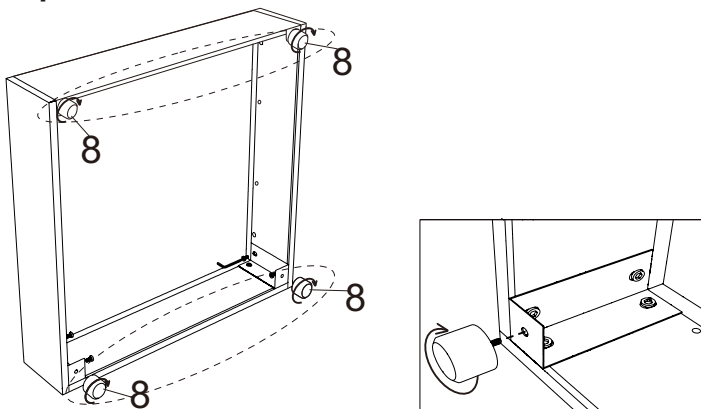

Step4

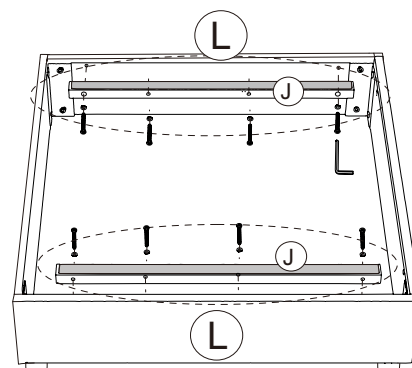

Face the Velcro upward.

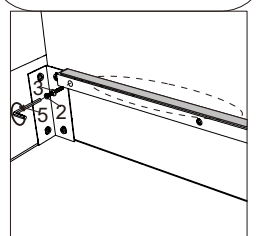

Step5

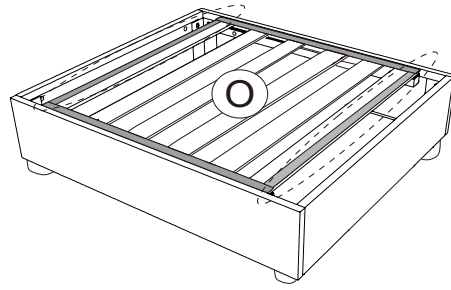
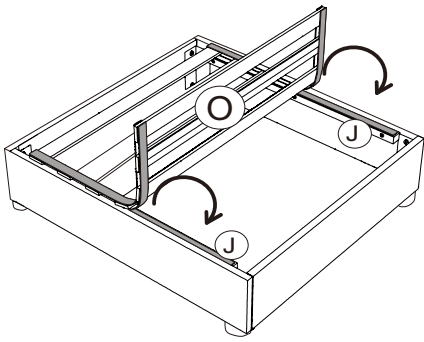

Face the Velcro upward.



Step6

