

# ASSEMBLY INSTRUCTIONS

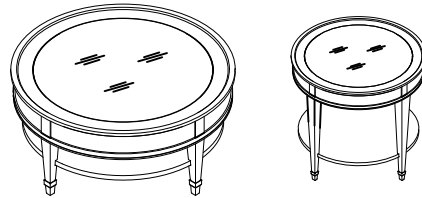

## TOOLS REQUIRED:

Allen Wrench (Provided, Part E)

## BEFORE YOU START:

1. Check the hardware against the hardware list to make sure all items are present.
2. Assemble your furniture on a soft, flat surface to avoid scratching the finish.
3. **CAUTION:** Do not over tighten screws, nuts or bolts during assembly.
4. Your furniture may require occasional tightening.

## INSTRUCTIONS:

1. Attach four legs to the bottom shelf, tighten the bolt (A) with Lock Washer (C) and Flat Washer (D) by Allen Wrench (E) as shown in Figure 1.

2. Turn the table top frame upside down on to a clean soft surface.

3. insert the four legs into the top apron and tighten the bolt (B) with Lock Washer (C) and Flat Washer (D) by Allen Wrench (E). Cover the bolts hole by plastic cap (F) as shown in Figure 2

4. Turn the table on to it's legs and carefully place the glass to the top frame as show in Figure 3.

Figure 1

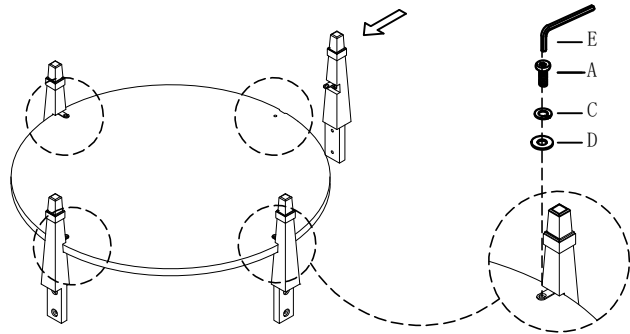

Figure 2

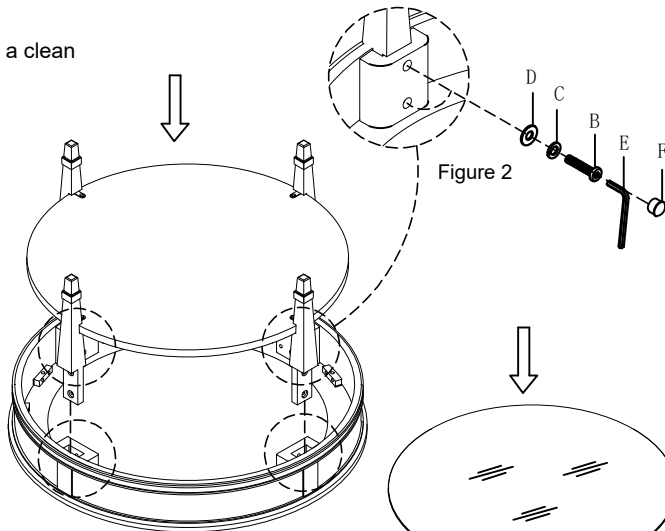
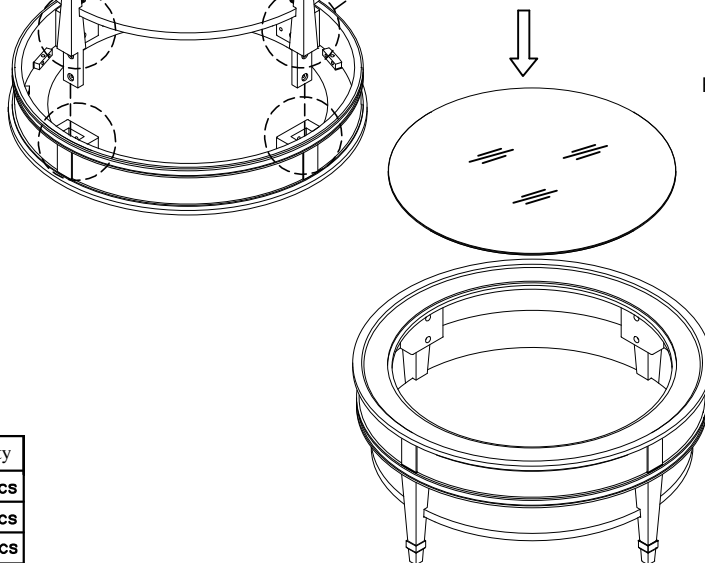

Figure 3



No.	HARDWARE LIST		Qty
A		Bolt (Ø1/4"*3/4")	4pcs
B		Long Bolt (Ø1/4"*1-1/2")	8pcs
C		Lock Washer (Ø1/4")	12pcs
D		Flat Washer (Ø1/4"*16mm)	12pcs
E		Allen Wrench (100*50*4mm)	1pc
F		Plastic Cap (3/4")	8pcs

