

Return for Writing Desk Instruction Sheet

STEPS:

1. (a,b) Get your piece at the height that's best for you by adjusting the levelers. If the levelers are too tight, use pliers to loosen and then adjust by hand. Get the unit in its desired location. Next, adjust the levelers to line up the tops. In order to increase the height, turn them counterclockwise. To lower the height, turn the levelers clockwise.
2. (a,b) To attach the legs, use a 7/16" wrench or ratchet and four bolts with washers. Lay the top of the piece upside down on a cleared off, flat surface. One leg at a time, line up the leg with the pre-drilled holes facing inward to the corner bracket on the desk top. With a washer on each bolt, insert the bolt through the hole on corner bracket and using the wrench or ratchet, screw the bolt into the predrilled hole on the leg. Repeat for all four legs.
3. (a,b) Attach the return to create an L-Shape Desk by using a Phillips head screwdriver and the three 1 1/4" screws provided. A second person will be needed to ensure proper alignment. With both pieces standing upright, one person holds the return in place (top of desk and return pressed tight with edges lined up), the other person gets under the desk and uses the screwdriver to drive screws through support board holes and into underside of top.
4. Care for your piece by dusting it with a slightly damp rag. Happy cleaning!

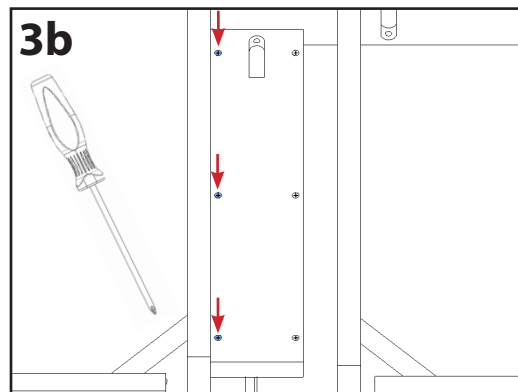
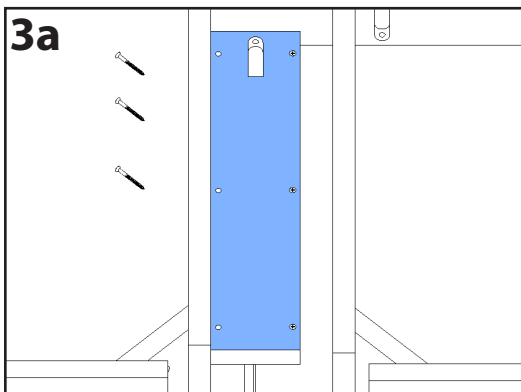
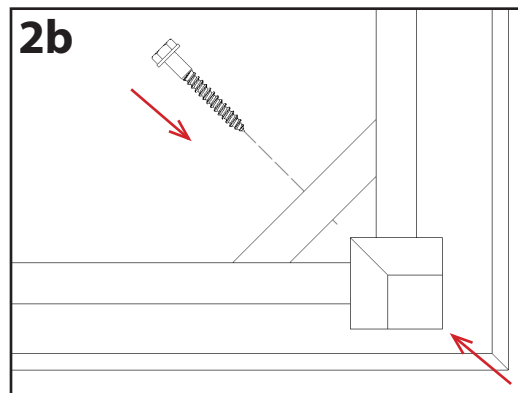
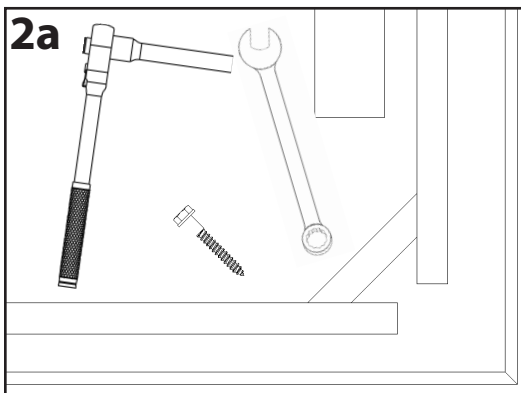
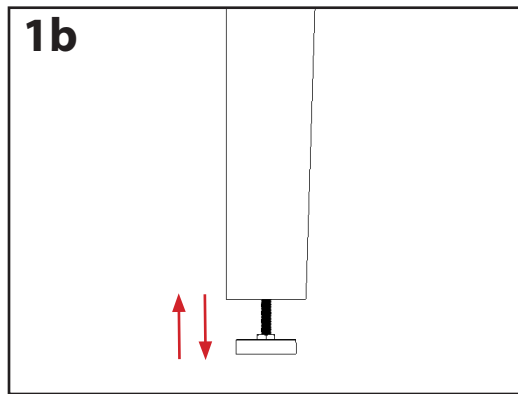
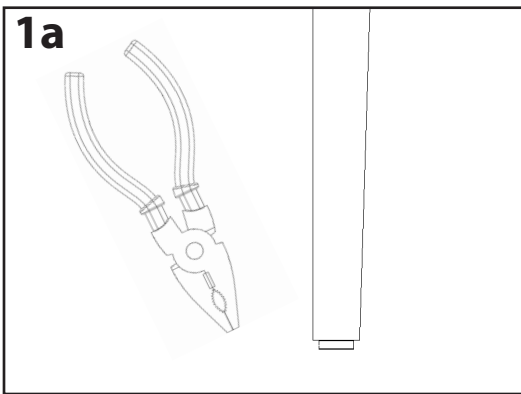

Hardware Provided:

- Legs x 4
- Levelers x 4
- 2" Lag Bolts & Washers
- 1 1/4" wood screws x 3

Tools Needed:

- Phillips head screwdriver
- Pliers
- 7/16" wrench or ratchet