

Assembly Instructions

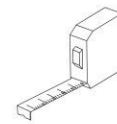

General Assembly Guidelines

- I. Ensure that all parts and hardware are available before beginning assembly.
- II. Follow each step carefully to ensure the proper assembly of this product.
- III. Two people are recommended for ease in the assembly of this product.
- IV. The three main types of hardware used to assemble this product are wood dowels, screws and bolts.
- V. A hammer, a Phillips head screwdriver and a tape measure are required for the assembly of this product.

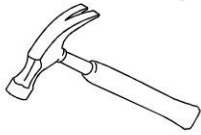

Tape measure

- VI. Power tools should not be used to assemble this product.

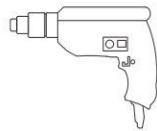

VII. Maintenance Guide

To maintain long term performance and easy gliding of your solid wood drawers, we recommend applying wax to the wooden guide rails.

1. Bee's wax is recommended or Paraffin wax from a standard candle can be used.
2. Apply the wax by rubbing it on the wooden guide rails where there is wood-on-wood contact when opening and closing the drawer. (Wax should be room temperature, do not melt the wax onto the wood)
3. Wax should be applied every few months for the first year and then only when needed after that to keep the drawers sliding smoothly.

Parts List

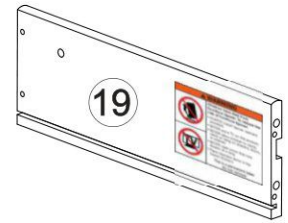

The side drawer with WARNING LABEL, should be mounted in highest drawer.

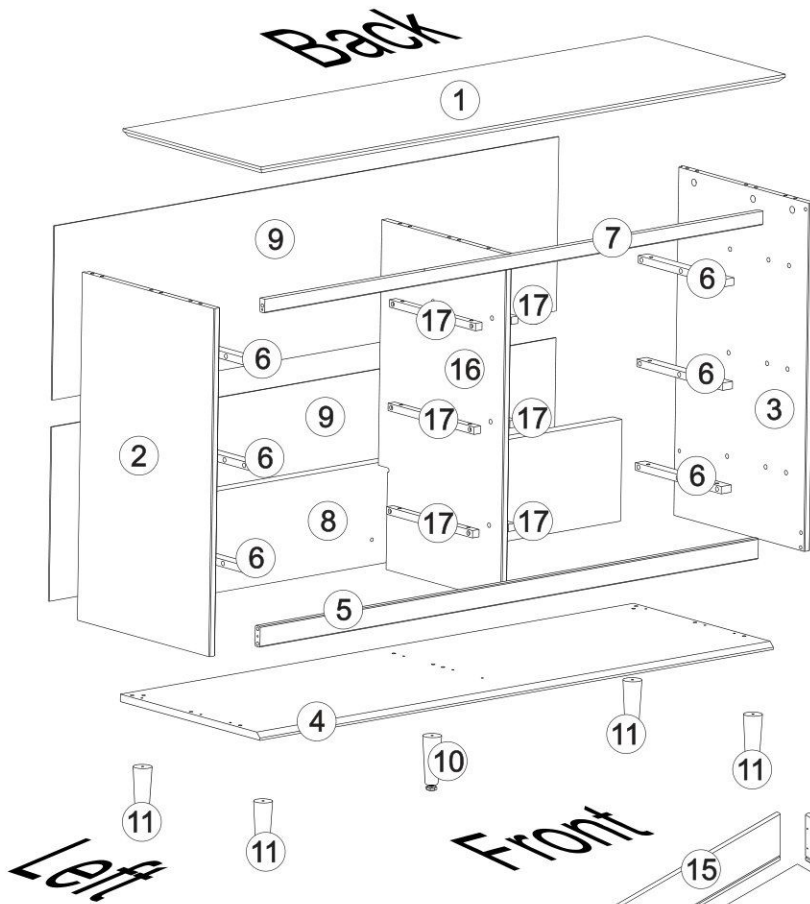

WARNING

Children have died from furniture tipover. To reduce the risk of furniture tipover:

- ALWAYS install tipover restraint provided.
- NEVER put a TV on this product.
- NEVER allow children to stand, climb or hang on any drawers, doors, or shelves.
- Never open more than one drawer at a time.
- Place heaviest items in the lowest drawers.

This is a permanent label. Do not remove!



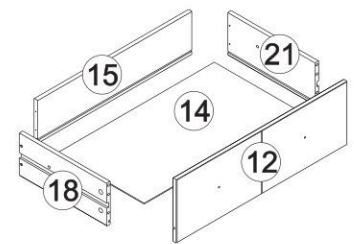
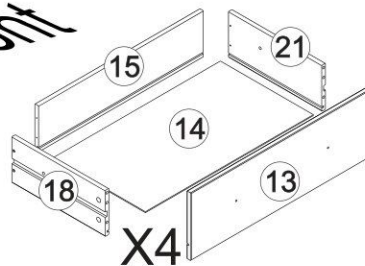
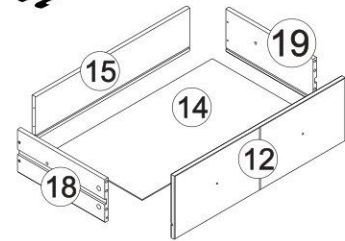







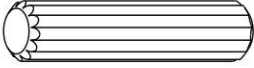
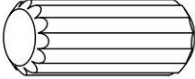

Right









Part#	Description	Qty
1	Top panel	01 pc
2	Left side panel	01 pc
3	Right side panel	01 pc
4	Bottom panel	01 pc
5	Bottom front rail	01 pc
6	Large Wood Slider	06 pcs
7	Upper front rail	01 pc
8	Back rail	01 pc
9	Back panel	02 pcs
10	Center foot	01 pc

Part#	Description	Qty
11	Foot	04 pcs
12	Upper drawer front	02 pcs
13	Drawer front	04 pcs
14	Drawer bottom	06 pcs
15	Drawer back	06 pcs
16	Division	01 pc
17	Wood slider	06 pcs
18	Left drawer slide	06 pcs
19	Right drawer side with warning	01 pc
21	Right drawer side	05 pcs

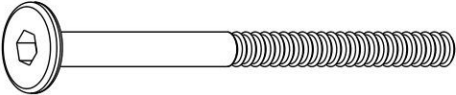
Hardware List

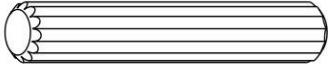
A		Ø8*30mm	Wooden dowel	51 pcs
B		Ø10*20mm	Wooden dowel	36 pcs
C		Ø4*25mm	Screw	36 pcs
D		Ø3,5*30mm	Screw	34 pcs
E		M4*22mm	Screw	12 pcs
F		Ø4,0*40mm	Screw	10 pcs
G		10*7	Nail	36 pcs
H			Knob	12 pcs
I		Ø3,5*14mm	Screw	08 pcs
J		1374mm	"H" Profile	01 pc
K			Wall anchor	01 pc
L			Washer	02 pcs
M		Ø6mm	Wall fixer	01 pc

Hardware List

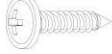
N		Ø7*80mm	Screw	05 pcs
O			Hex key	01 pc
P		Ø8*40mm	Wooden dowel	12 pcs
Q		ø5,0*24mm	Cam Bolt	35 pcs
R		ø15*12mm	Cam Lock	35 pcs
S		75*50mm	sheet metal	2 pcs
T		Ø4*16mm	Screw	1 pc



Hammer recommended
for assembly (not included)



Philips head screwdriver required
for assembly (not included)

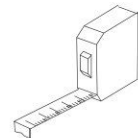

Tape measure
required
for assembly
(not included)

*The hardware quantities listed above are required for proper assembly.
Some extra hardware may also have been included.*

Step 1

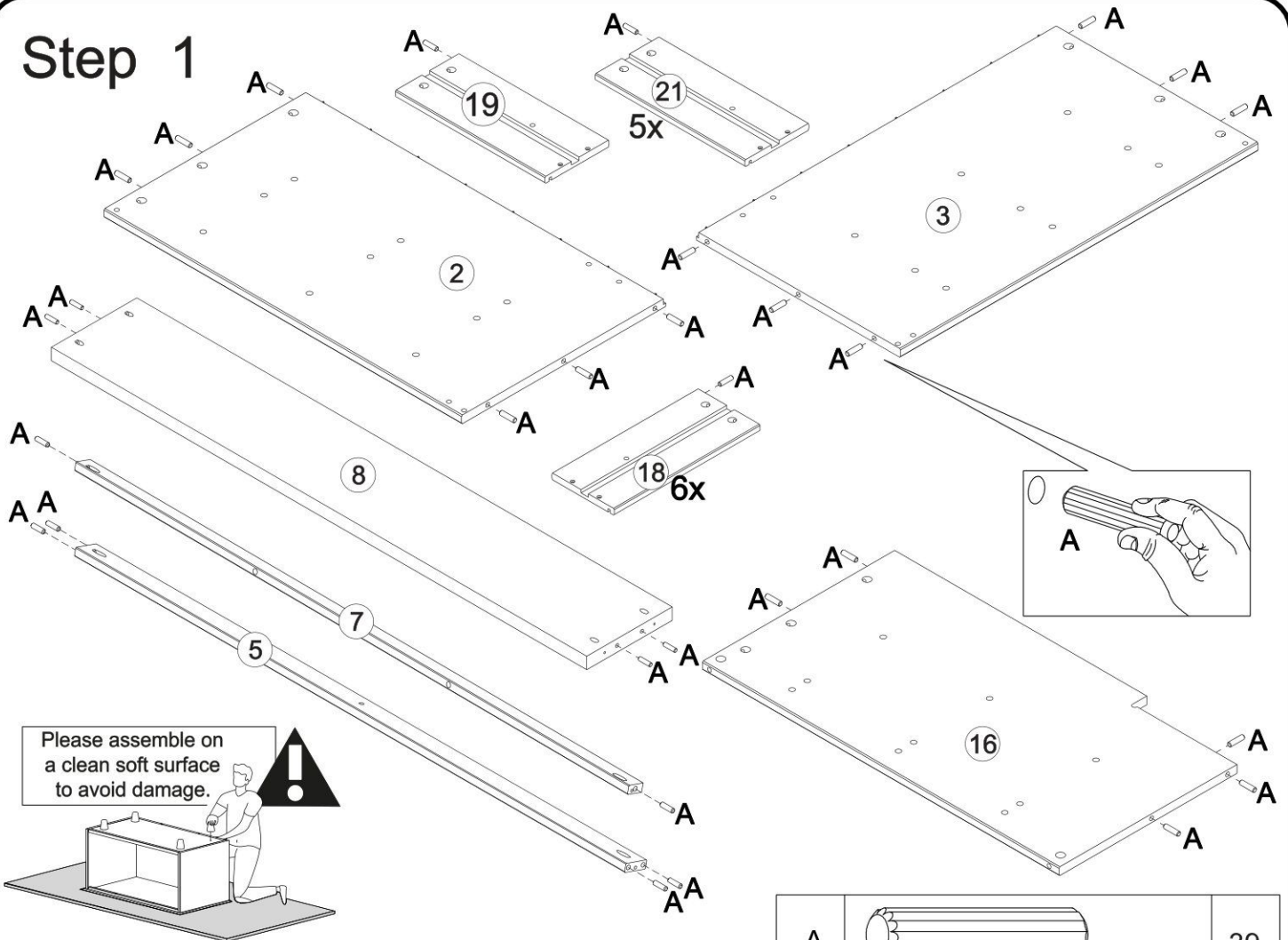

Insert wood dowel (B) into parts 2,3,5,7,8,16,18,19 and 21.

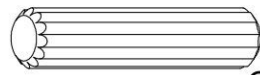
A		39
		Ø8*30mm

Step 2

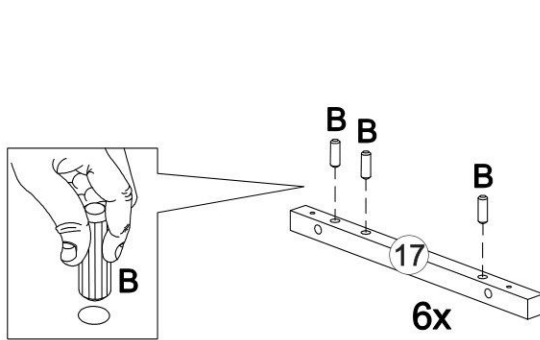

Attention to the dowel length: Ø10*20mm

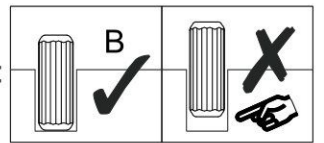

Insert wood dowel (B) into part 17.

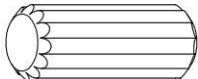
B		18
		Ø10*20mm

Step 3

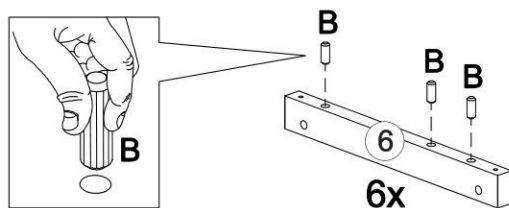

Attention to the dowel length: Ø10*20mm

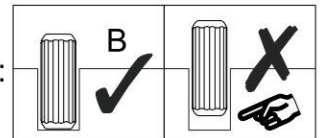

Insert wood dowel (B) into part 6.

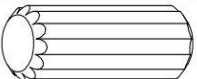
B		18
		Ø10*20mm

Step 4

1 - Ensure cam bolt is installed straight and not at an angle.
 2 - Tighten cam bolt until shoulder on cam bolt is flush. Do not over-tighten.

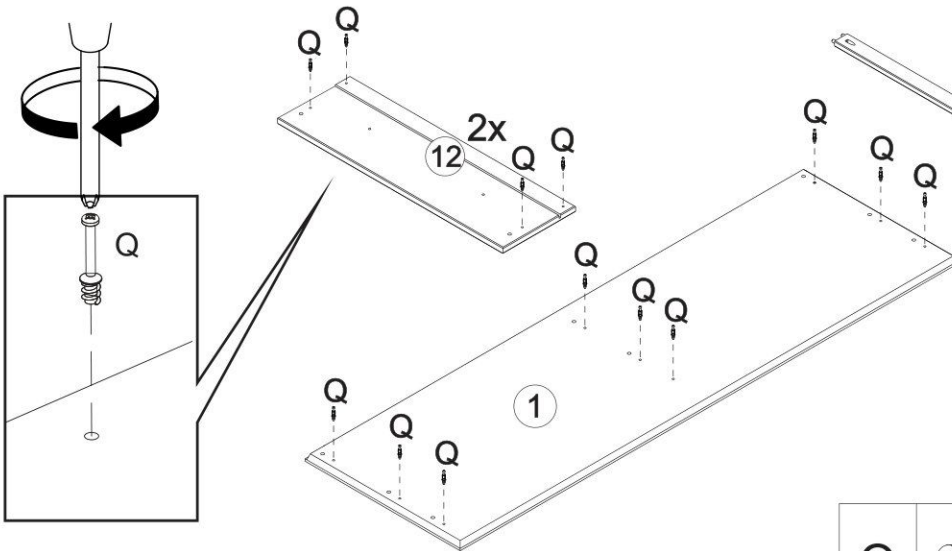
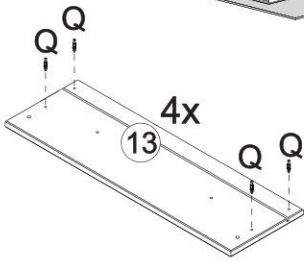
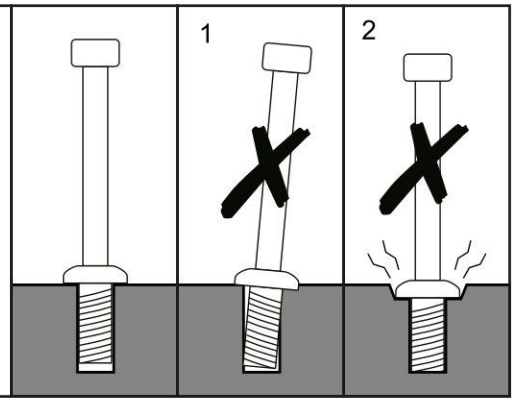

Insert Cam Bolt (Q) into parts 1,5,7,12 and 13 using Phillips head screwdriver.

Q		35
		ø5,0*24mm

Step 5

TOP

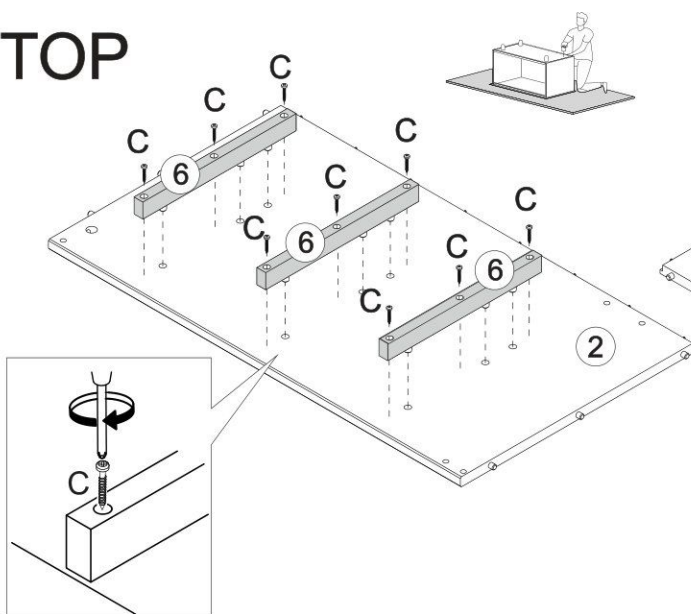

TOP

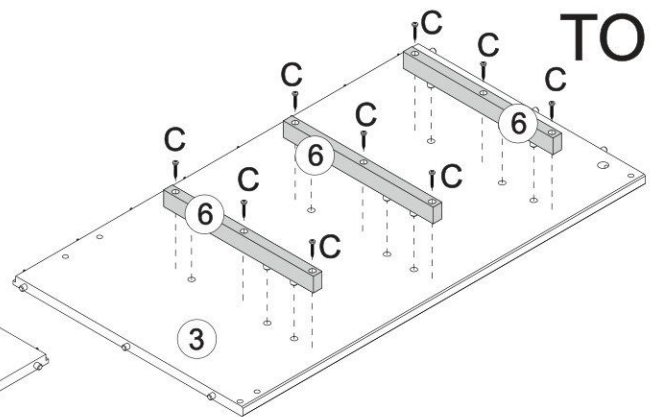

Secure part 6 to parts 2 and 3 with screw (C) using a Phillips head screwdriver.

C		18
		Ø4*25mm

Step 6

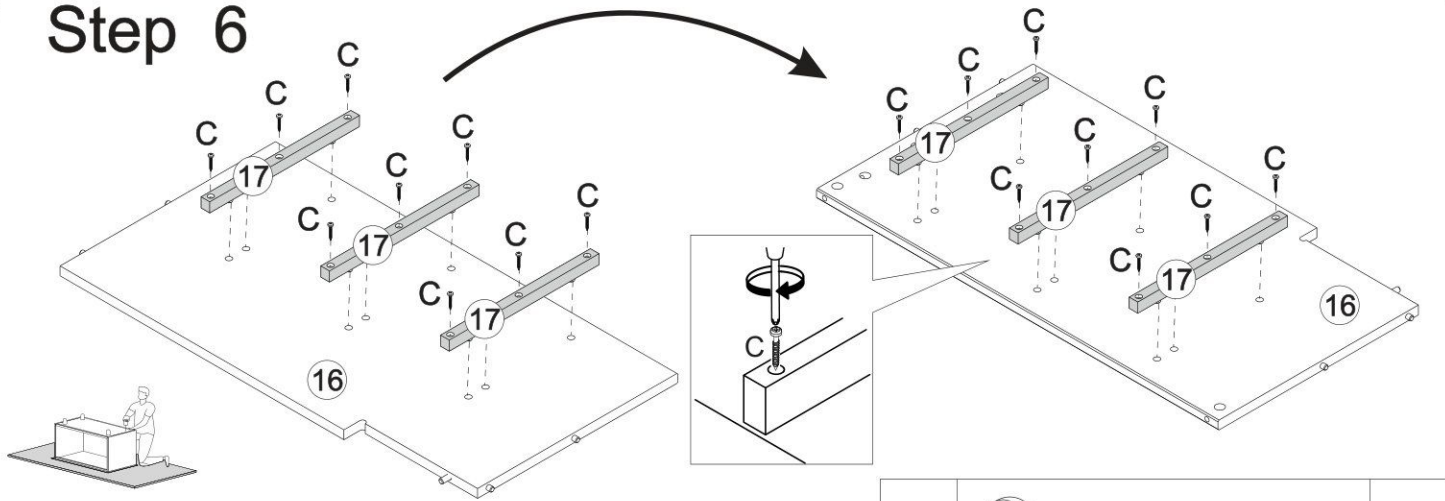

Secure part 17 to part 16 with screw (C) using a Phillips head screwdriver.

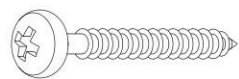
C		18
		Ø4*25mm

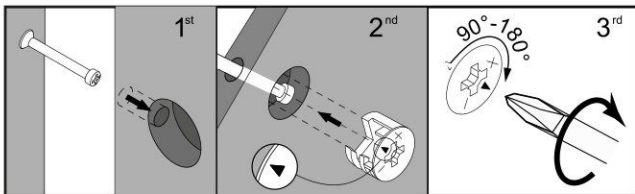

Align the opening in cam lock to the cam bolt and press into opening. Using a screwdriver, rotate the cam lock until it engages with the cam bolt and locks in place (anywhere between 90-180 degrees). Do not over-tighten the cam lock. Doing so may result in damaged or broken parts.

Step 7

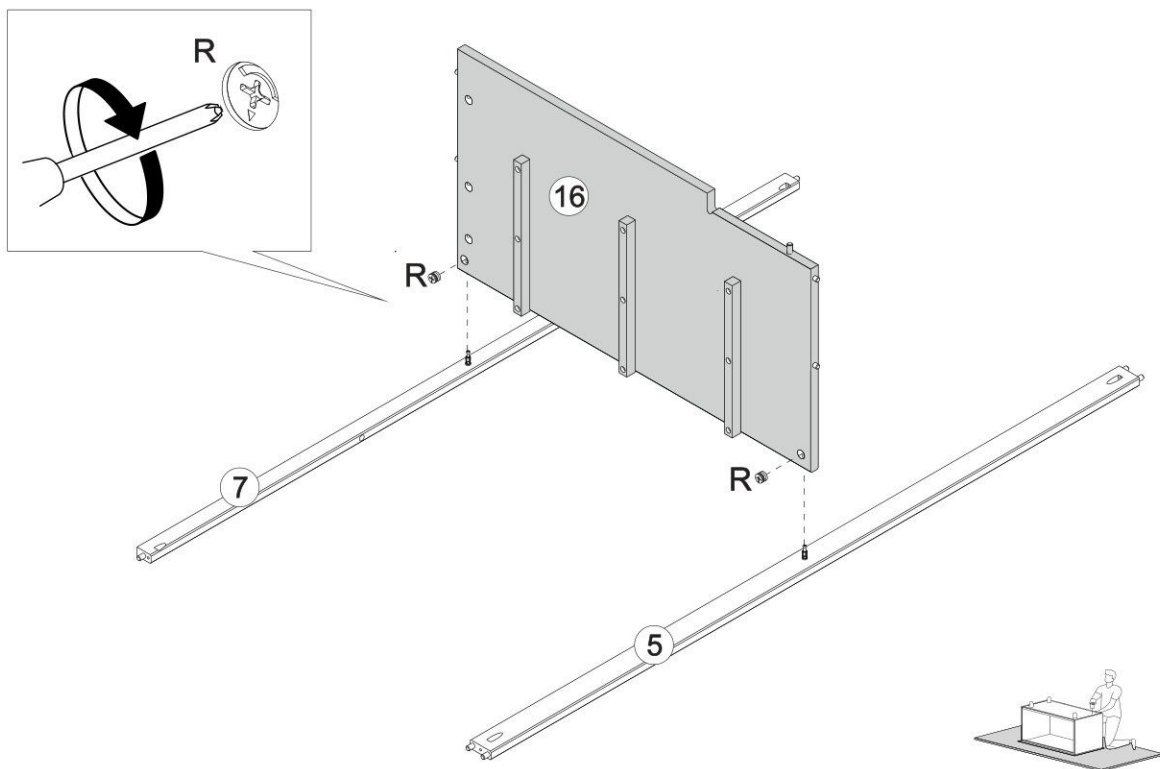

Secure part 16 to parts 5 and 7 with Cam Lock (R) using Phillips head screwdriver.

R		02
		ø15*12mm

Step 8

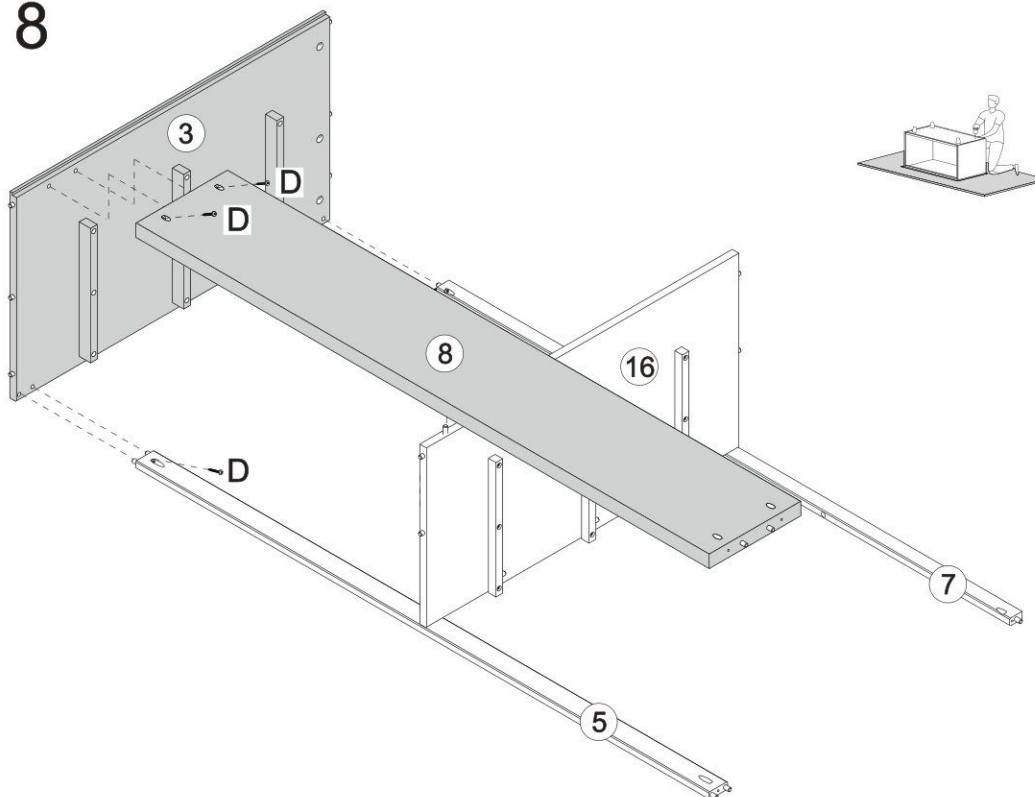

Join part 8 to part 16,
Join part 3 to parts 5,7 and 8,
Secure part 3 to parts 5 and 8
with screw (D) using Phillips head screwdriver.

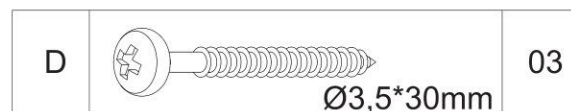

Step 9

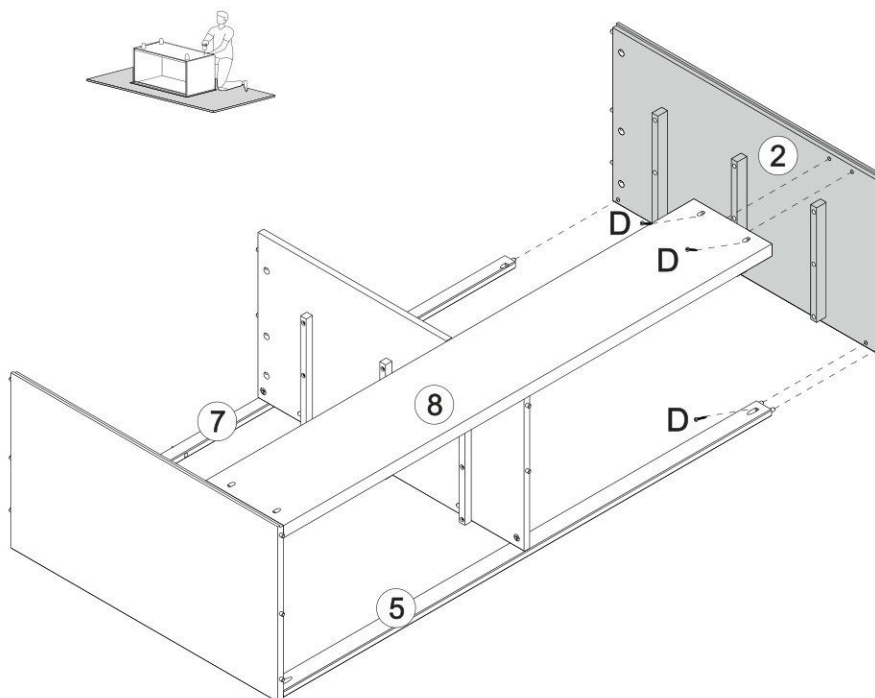

Join part 2 to parts 5,7 and 8,
Secure part 2 to parts 5 and 8
with screw (D) using Phillips head screwdriver.

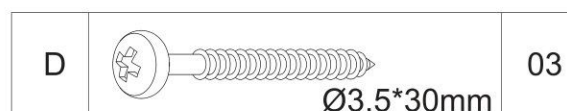

Step 10

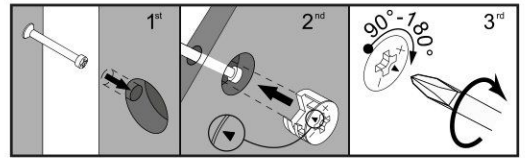
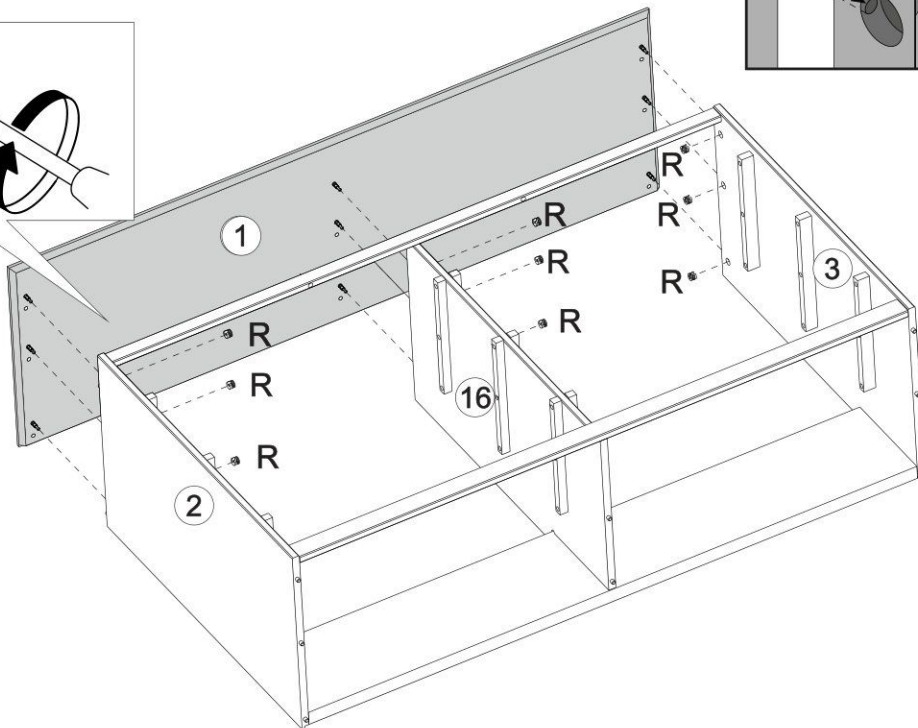
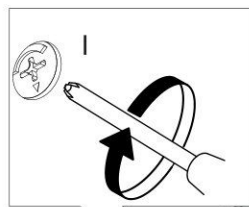

Secure part 1 to parts 2,3 and 16 with Cam Lock (R) using Phillips head screwdriver.

R		ø15*12mm	09
---	--	----------	----

Step 11

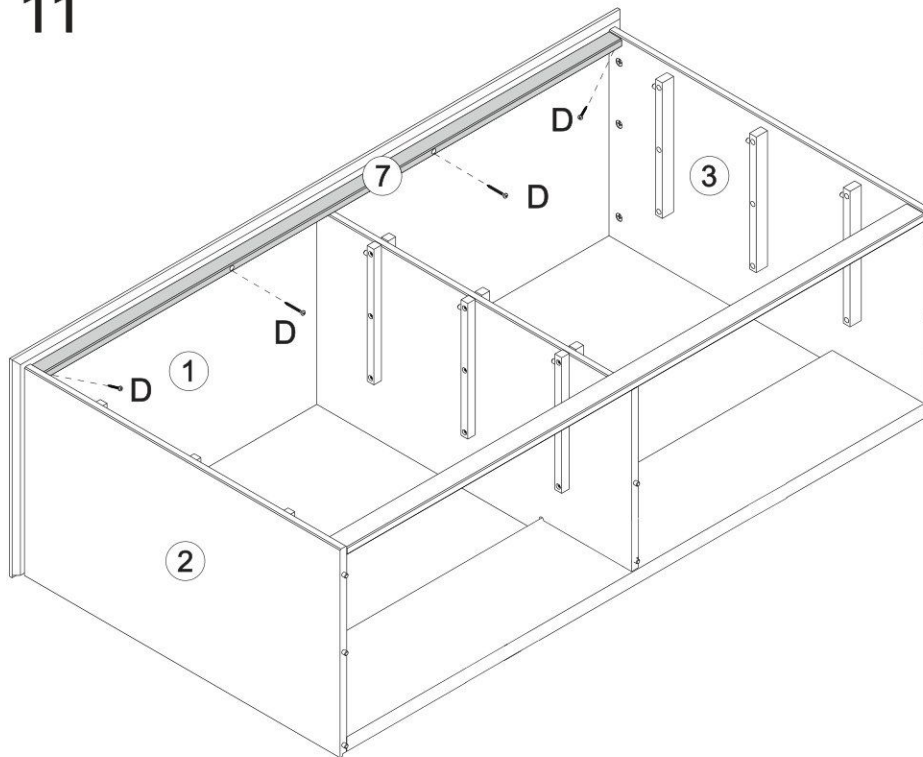

Secure part 7 to parts 1,2 and 3 with screw (D) using Phillips head screwdriver.

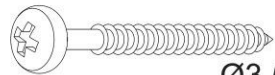
D		Ø3,5*30mm	04
---	---	-----------	----

Step 12

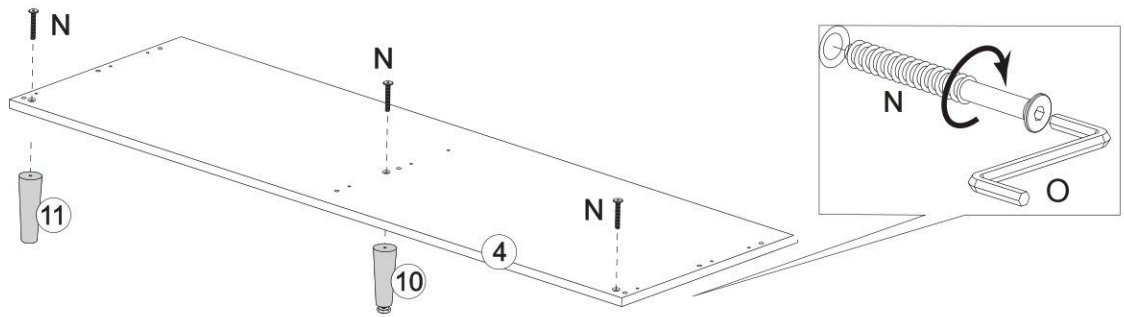

Secure part 4 to parts 10 and 11 with screw (N) Hex Key (O).

	O		01
N		$\text{Ø}7*80\text{mm}$	03

Step 13

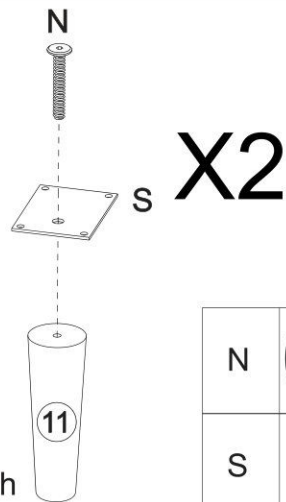

Secure part 11 to hardware (S) with screw (N) using a Hex Key (O).

	O		01
N		$\text{Ø}7*80\text{mm}$	02
S		75*50mm	02

Step 14

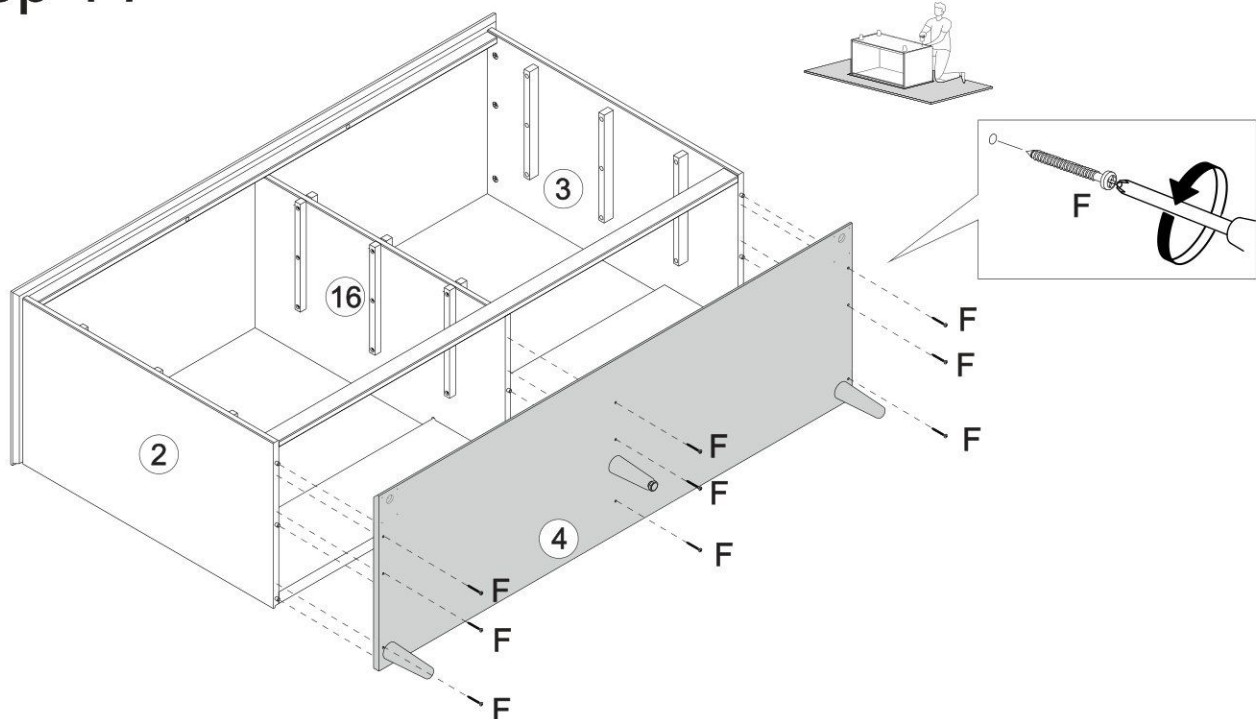

Secure part 4 to parts 2,3 and 16 with screw (F) using Phillips head screwdriver.

F		$\text{Ø}4,0*40\text{mm}$	9
---	--	---------------------------	---

Step 15

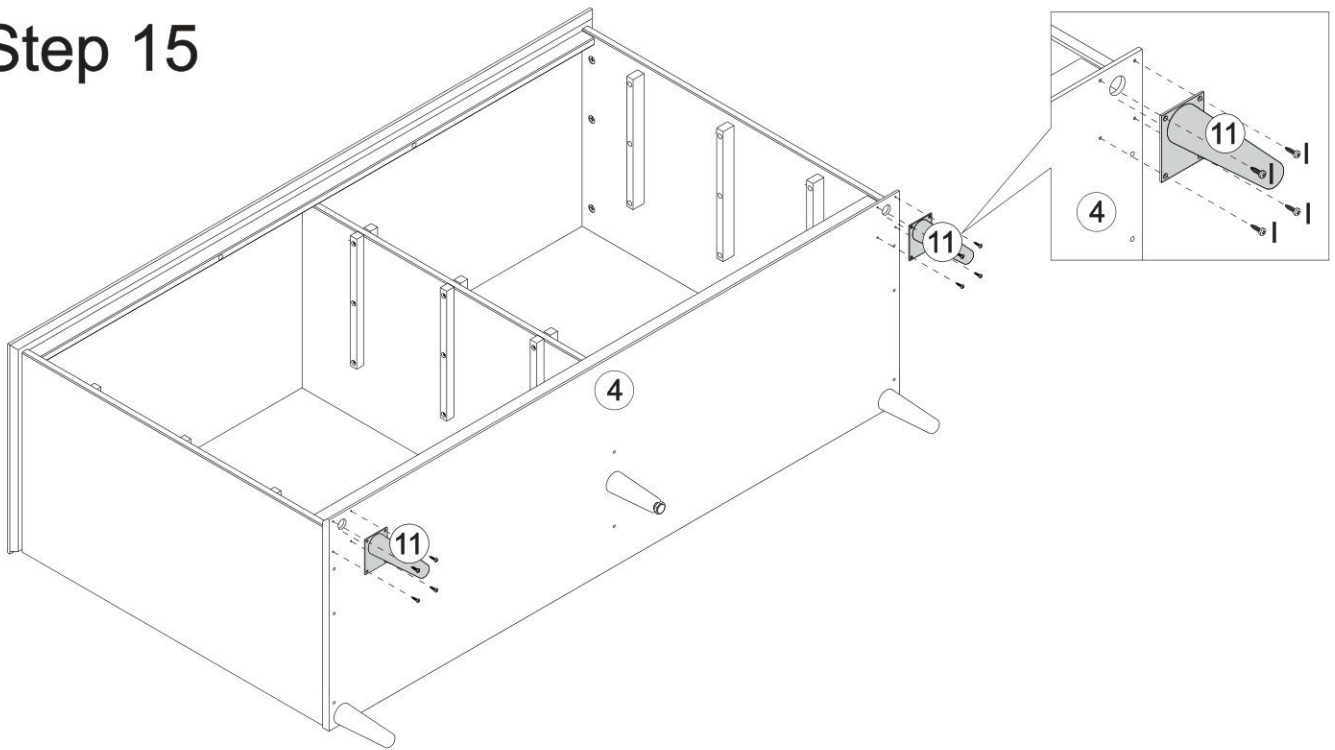

Secure part 11 to part 4 with screw (I) using a Phillips head screwdriver.

I		08
$\text{Ø}3,5 \times 14\text{mm}$		

Step 16

Secure part 9 with hardware (J) to parts 1,2,3,8 and 16 with nails (G) using a hammer.

Name and address of the supplier and date of production.

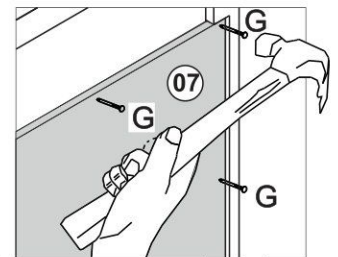

G		36
$\text{Ø}10 \times 10$		
J		01
"H" Profile 1374mm		

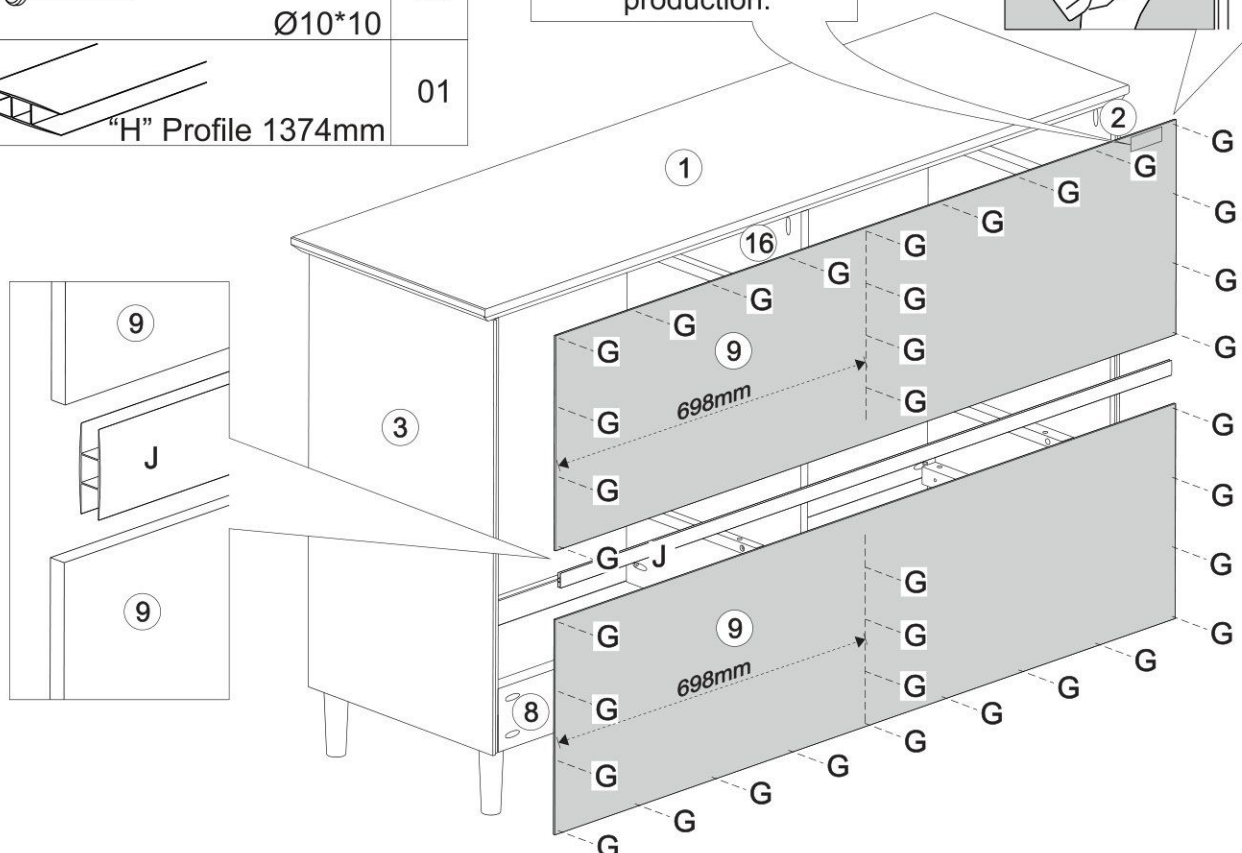

Step 17

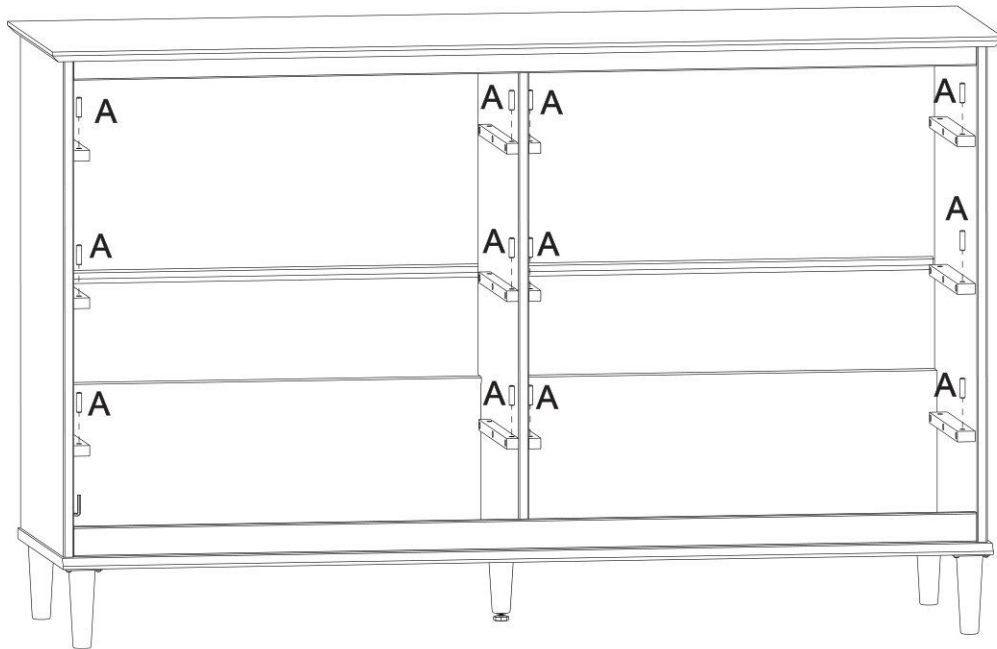

Insert wood dowel (A) into the front hole in the wood sliders 6 and 17.

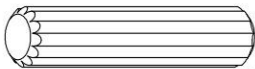
A		12
$\varnothing 8 * 30 \text{mm}$		

Step 18

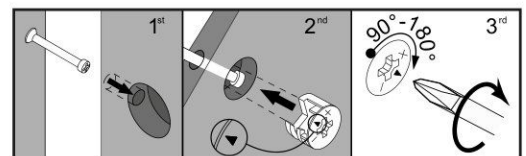
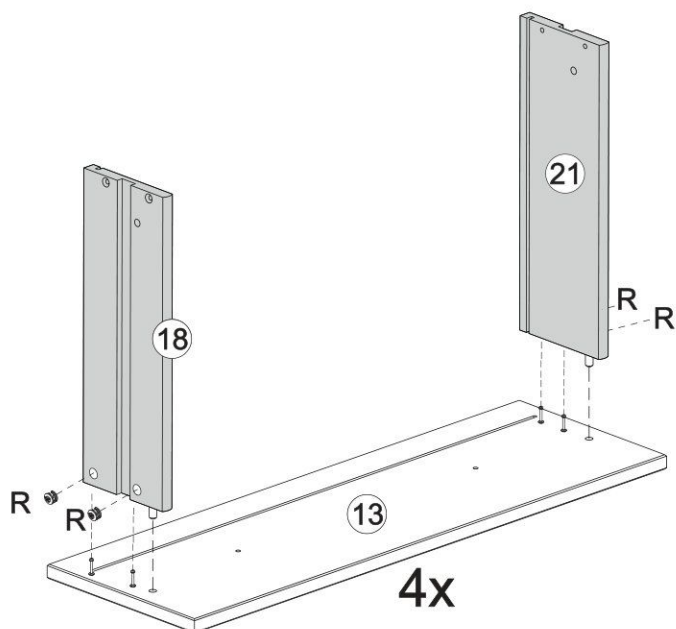

Secure part 21 and 18 to parts 13 with Cam lock (R) using a Phillips head screwdriver.

R		16
$\varnothing 15 * 12 \text{mm}$		

Step 19

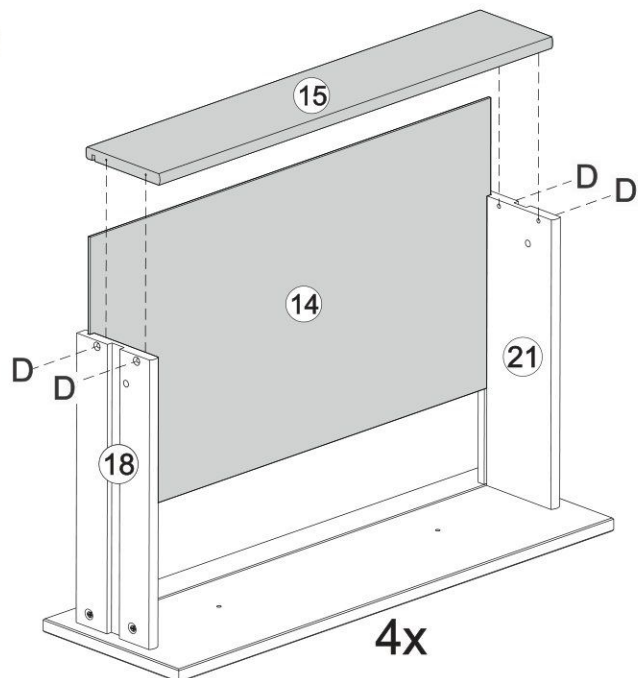

Insert part 14 into parts 18 and 21 grooves
secure part 15 with screw (D) using a
Phillips head screwdriver.

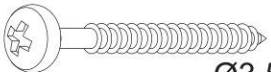
D		16
$\text{Ø}3,5 \times 30\text{mm}$		

Step 20

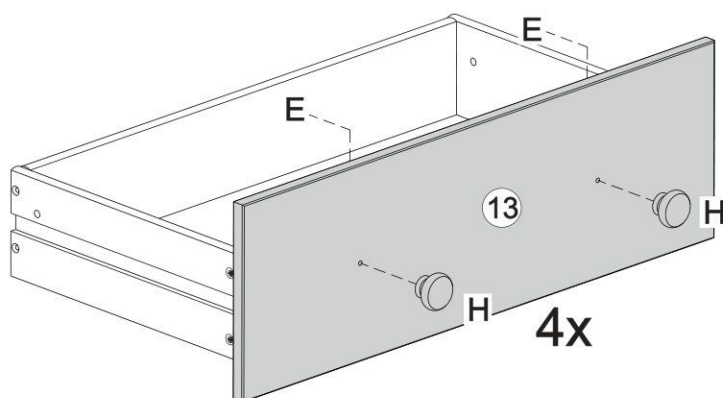

Secure knob (H) with screw (E)
using a Phillips head screwdriver.

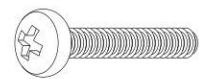
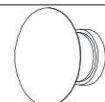
E		08
$M4 \times 22\text{mm}$		
H		08

Step 21

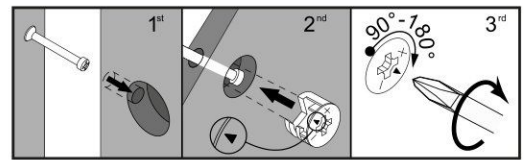
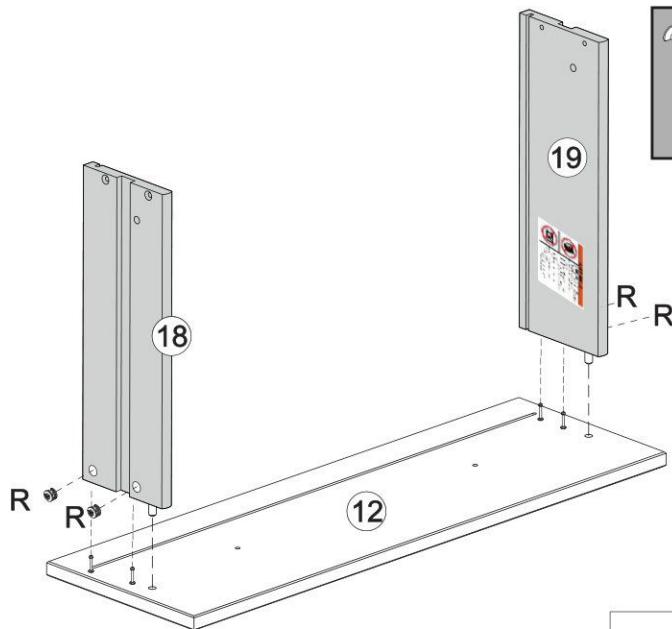

Secure parts 19 and 18 to part 12 with Cam lock (R) using a Phillips head screwdriver.

R		Ø15*12mm	04
---	---	----------	----

Step 22

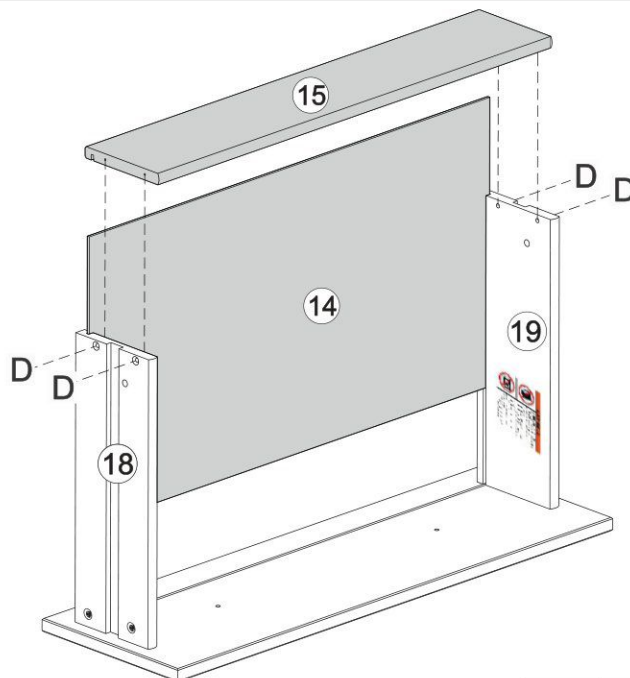

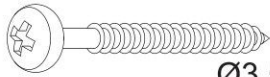

Insert part 14 into parts 18 and 19 grooves secure part 15 with screw (D) using a Phillips head screwdriver.

D		Ø3,5*30mm	04
---	---	-----------	----

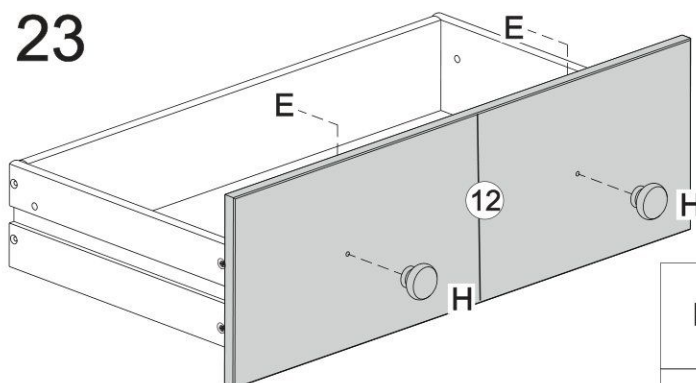
Step 23

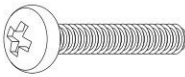

Secure knob (H) with screw (E) using a Phillips head screwdriver.

E		M4*22mm	02
H			02

Step 24

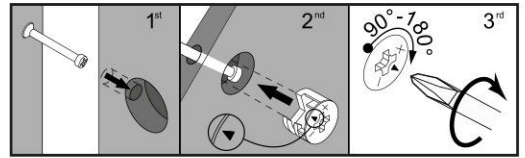
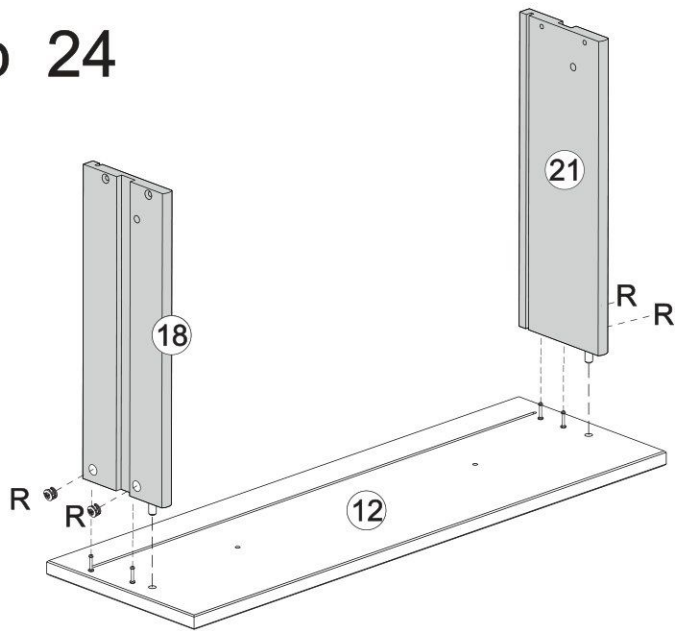

Secure parts 21 and 18 to part 12 with Cam lock (R) using a Phillips head screwdriver.

R		ø15*12mm	04
---	--	----------	----

Step 25

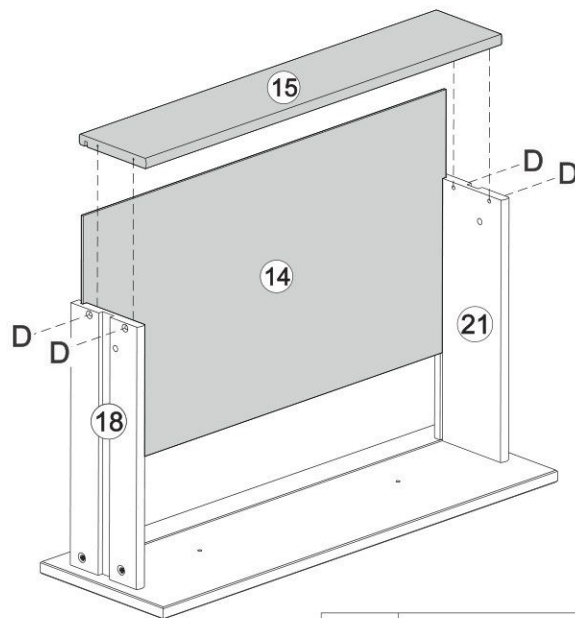

Insert part 14 into parts 18 and 21 grooves secure part 15 with screw (D) using a Phillips head screwdriver.

D		Ø3,5*30mm	04
---	--	-----------	----

Step 26

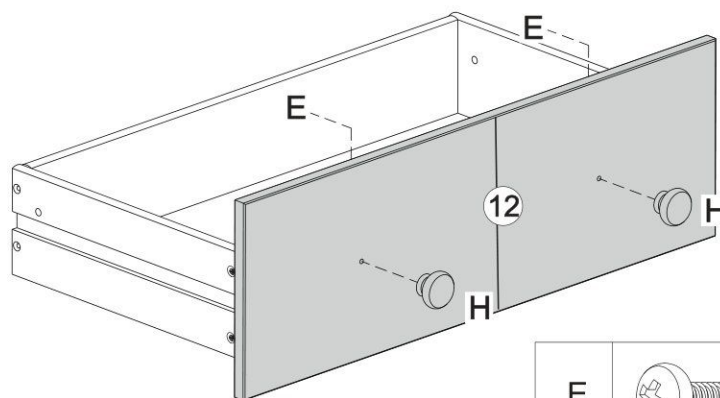

Secure knob (H) with screw (E) using a Phillips head screwdriver.

E		M4*22mm	02
H			02

Step 27

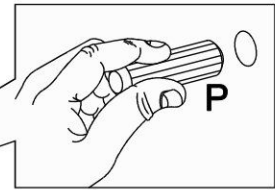
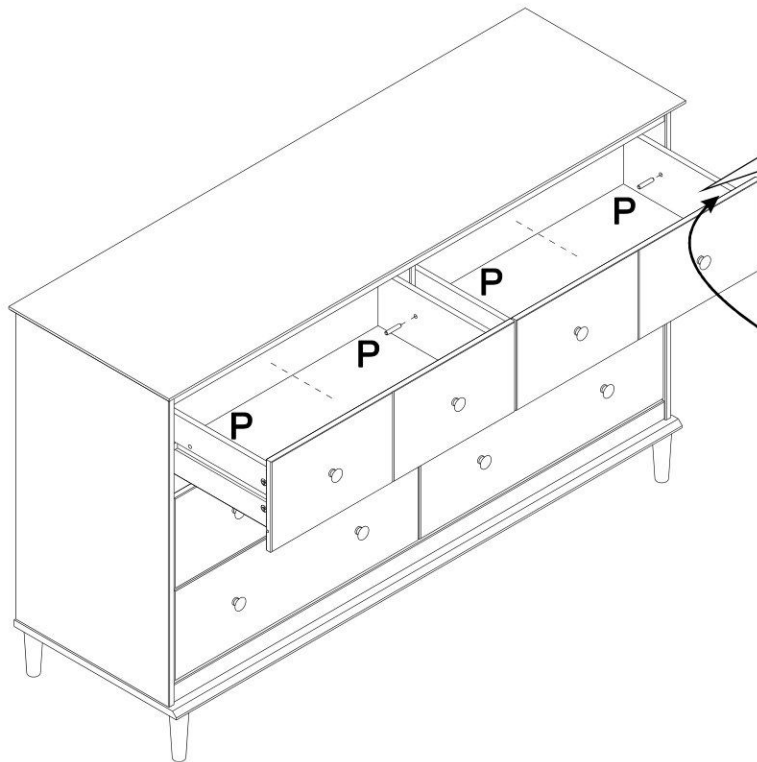

The assembled drawer with this warning must be placed on top of the unit.



Insert wood dowel (P) on the inside of all drawers, with the drawer inside the unit, after having passed the wood dowel that is in the drawer slide. The dowel is not flush with the panel, it is a little inside the drawer to help when you need to remove the lock dowel to remove the drawer.

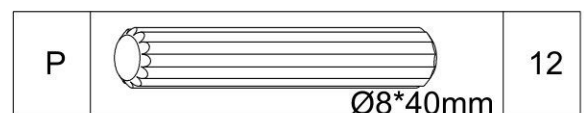

Step 28

WARNING

Serious or fatal injuries can occur from furniture tipping over. To prevent the furniture from tipping over we recommend that it is permanently fixed to the wall.

Wall anchor and hardware are included with this product. Please make sure hardware is suitable for your walls before installing, as different wall materials may require different types of anchors.

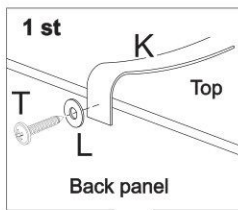

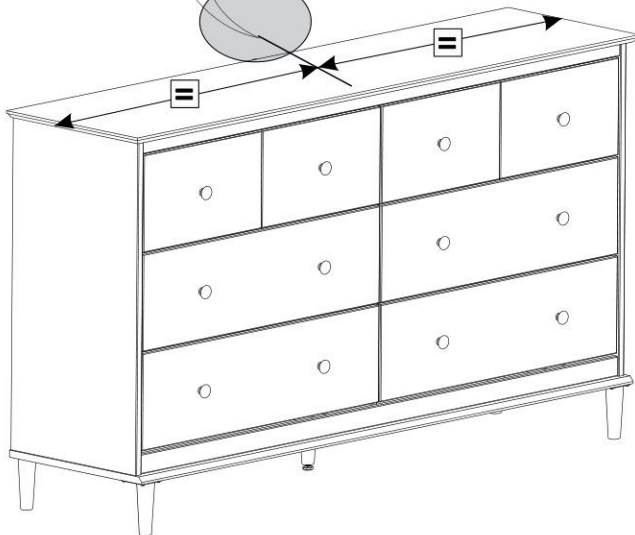
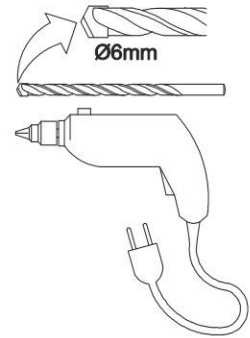

Attach part (K) with Screw (T) and Washer (L), in the frame of the top panel unit.

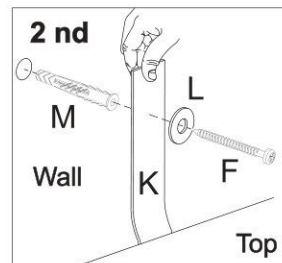

With the drilling machine make one hole in the wall, Insert part (M) in the hole. Secure part (K) with Screw (F) and Washer (L), in the wall.

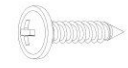
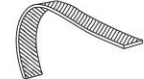
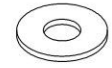

F		01
	Ø4,0*40mm	
T		01
	Ø4*16mm	
K		01
L		02
M		01
	Ø6mm	

Wall

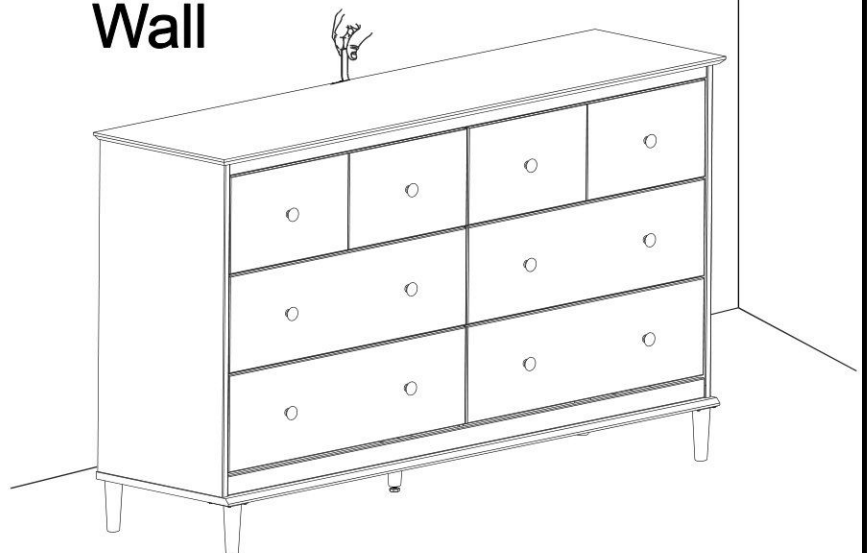

Name and address information for the manufacturer responsible for the anti-tip hardware and date of production can be found on the label on the back of the furniture.

Step 29

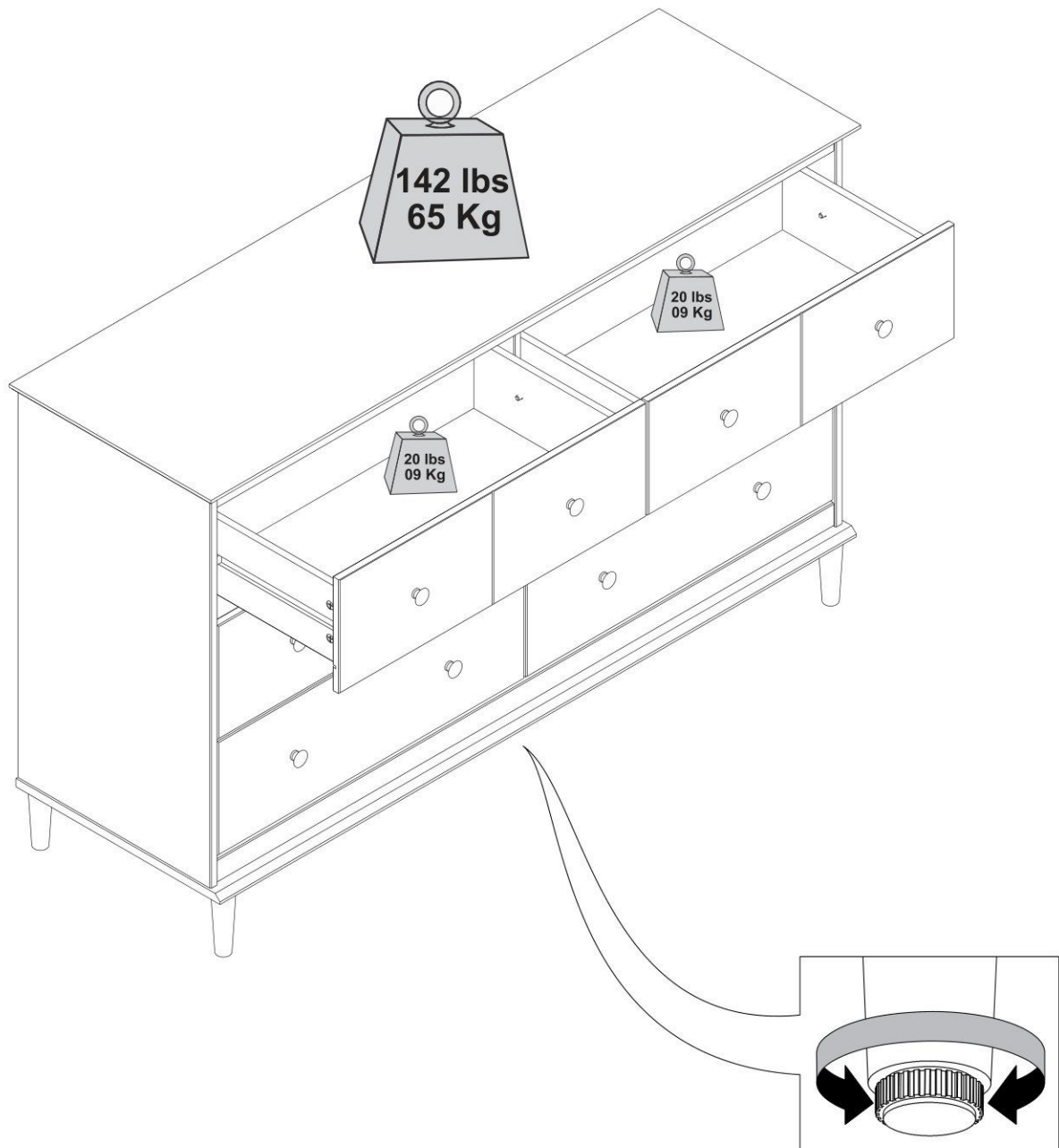

Assembly Complete!