

Assembly Instructions

Caution: You must read this before you proceed.

Please look in the Table Top for hardware packs.

Right Chair

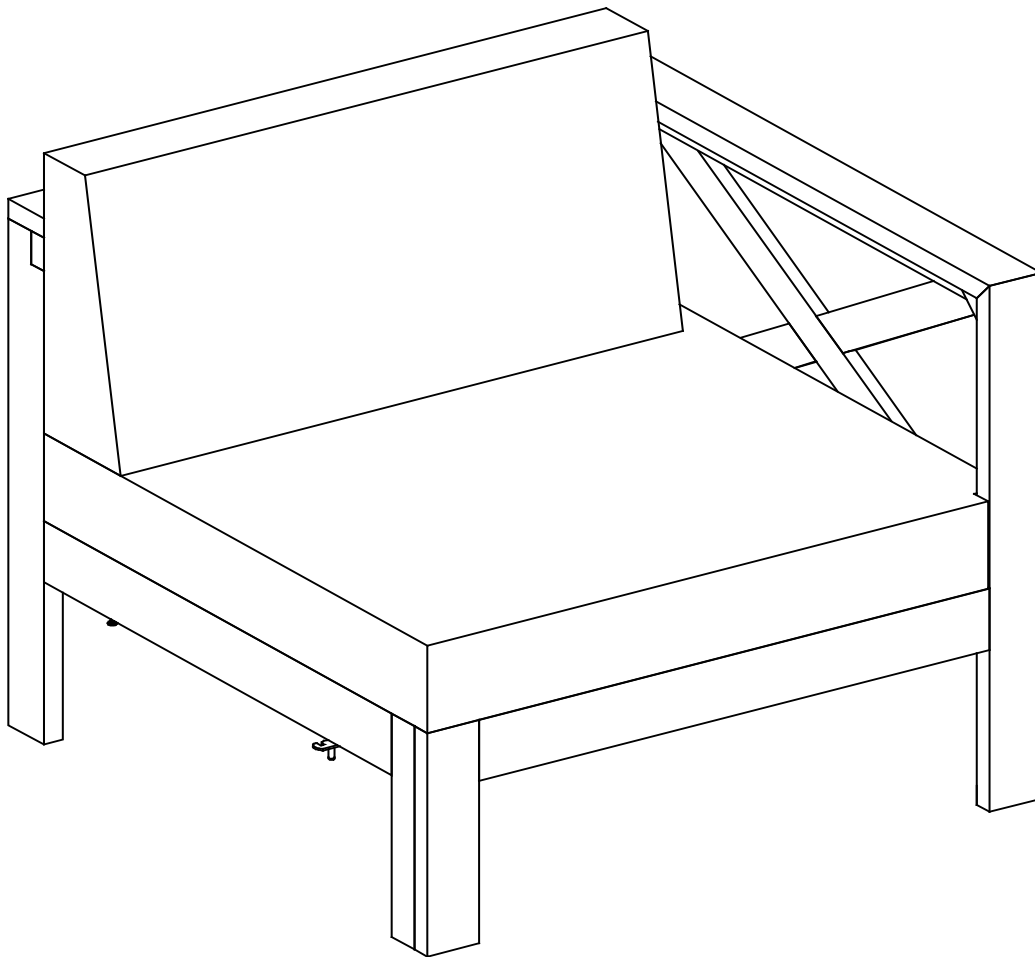

Caution: This Chair is NOT a TOY.



Keep your child/children at bay during the assembly process.

Whenever moving/lifting the Chair and to prevent damage to the Chair, two adults are needed to execute these actions.

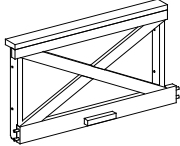
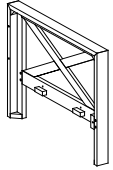
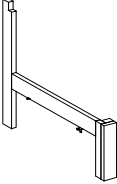
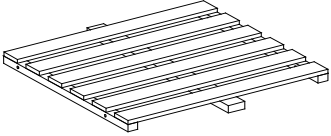
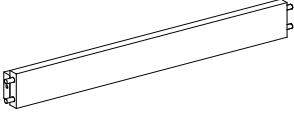
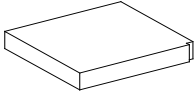
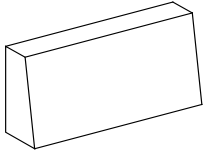
Parts List

Label	Picture	Description	Qty
N		Backrest Panel	1
O		Right Arm Panel (With Pre-installed Levellers)	1
P		Left Arm Panel (With Pre-installed Levellers)	1
Q		Seat Panel	1
R		Support Bar	1
S		Seat Cushion	1
T		Back Cushion	1

Hardware

No.	Picture	Description	Qty
⑩		Bolts (M6x35mm)	7
⑪		Screws (M6x45mm)	5
⑫		Allen Key	1

Assembly Preparation

Before Beginning Assembly:

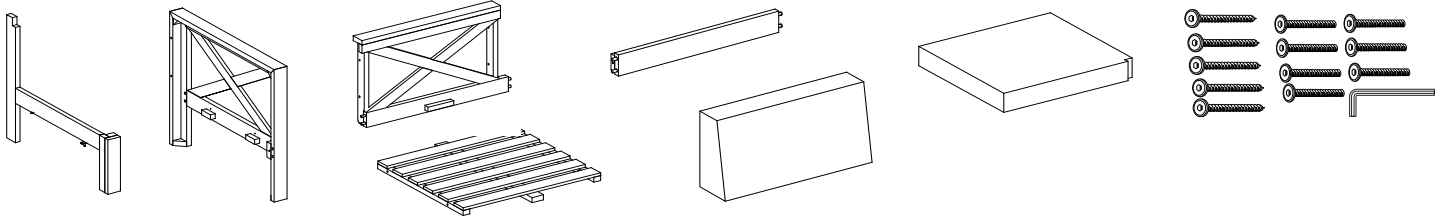

- Read instructions, cover to cover-



- Have 2 adults on hand for assembly-



- Do not assemble on flooring or carpet-



- Assemble on a clean non-marring surface (packing foam)-



- Save all packaging until finished-

Assembly Steps

OVERVIEW

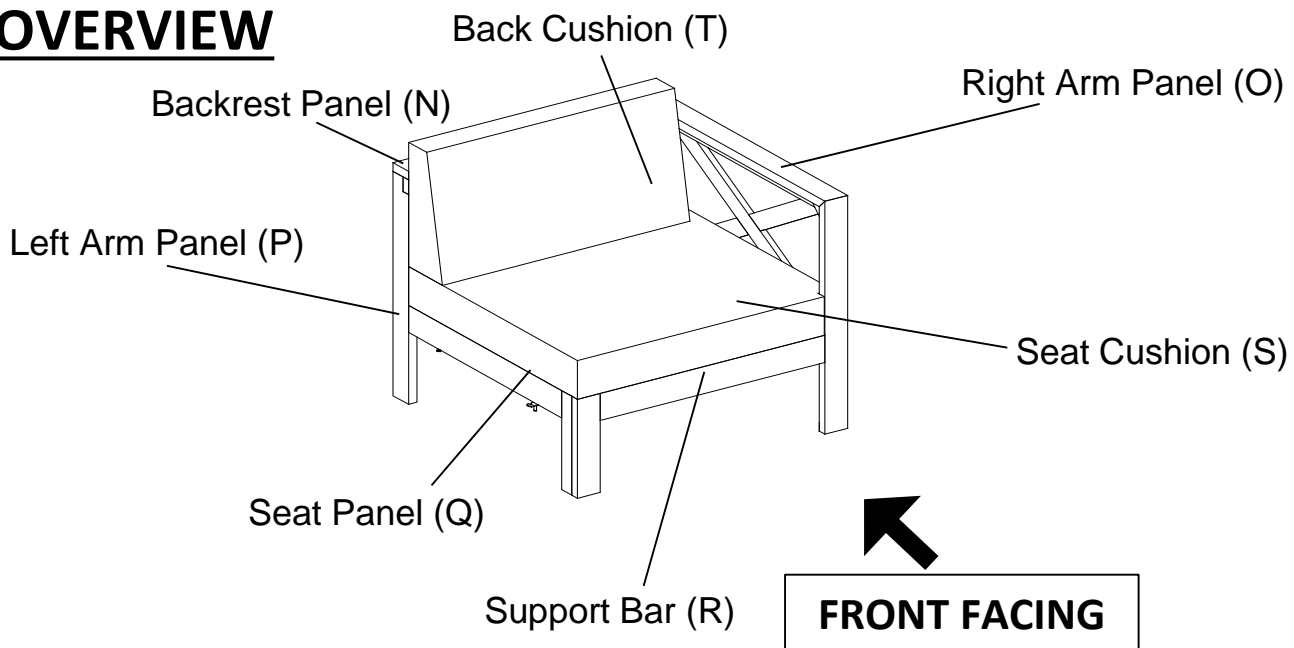

This Right Chair has multiple parts and may require up to 30 minutes to assemble. To give you an overview of the Right Chair parts, the above picture is to help you put the various parts into perspective. Please read through the instructions below to familiarise yourself with the parts and steps before assembly.

Step 1

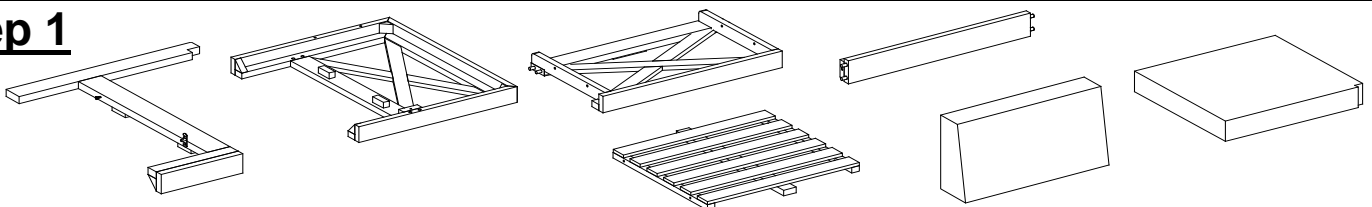

Unpack and place all parts on a clean, non-marring surface.

Step 2

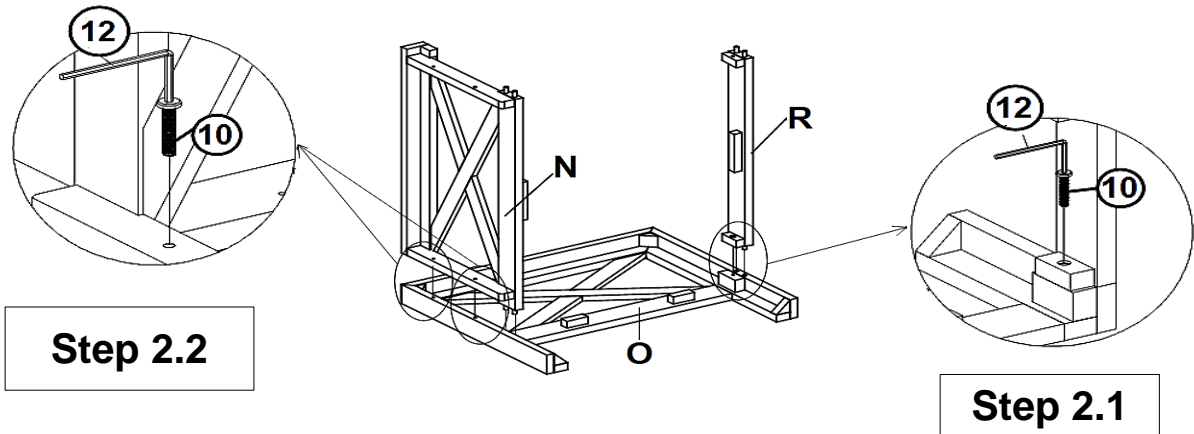

Place Right Arm Panel (O) facedown as pictured.

Step 2.1: Insert dowel on Support Bar (R) into housing on Right Arm Panel (O). Attach Support Bar (K) to Right Arm Panel (I) by using Bolt (10) and Allen Key (12).

Step 2.2: Insert dowels on Backrest Panel (G) into housings on Right Arm Panel (I). Attach Backrest Panel to Right Arm Panel (I) by using Bolts (10) and Allen Key (12).

DO NOT FULLY TIGHTHEN BOLTS.

Step 3

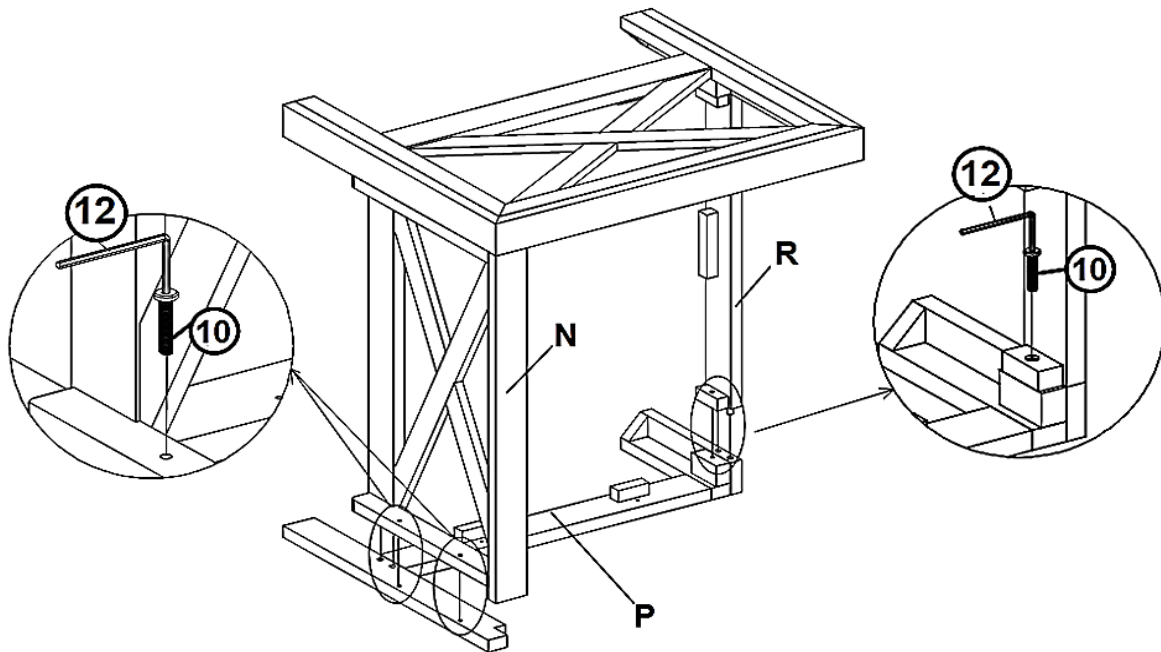

Place the Left Arm Panel (P) facedown as pictured.

With the help of your adult partner, insert dowels on Support Bar (R) and Backrest Panel (N) of the pre-assembled in Step 2 into housings on Left Arm Panel (P) as shown above.

Attach Support Bar (R) and Backrest Panel (N) to Left Arm Panel (P) by using Bolts (10) and Allen Key (12).

DO NOT FULLY TIGHTHEN BOLTS.

Step 4

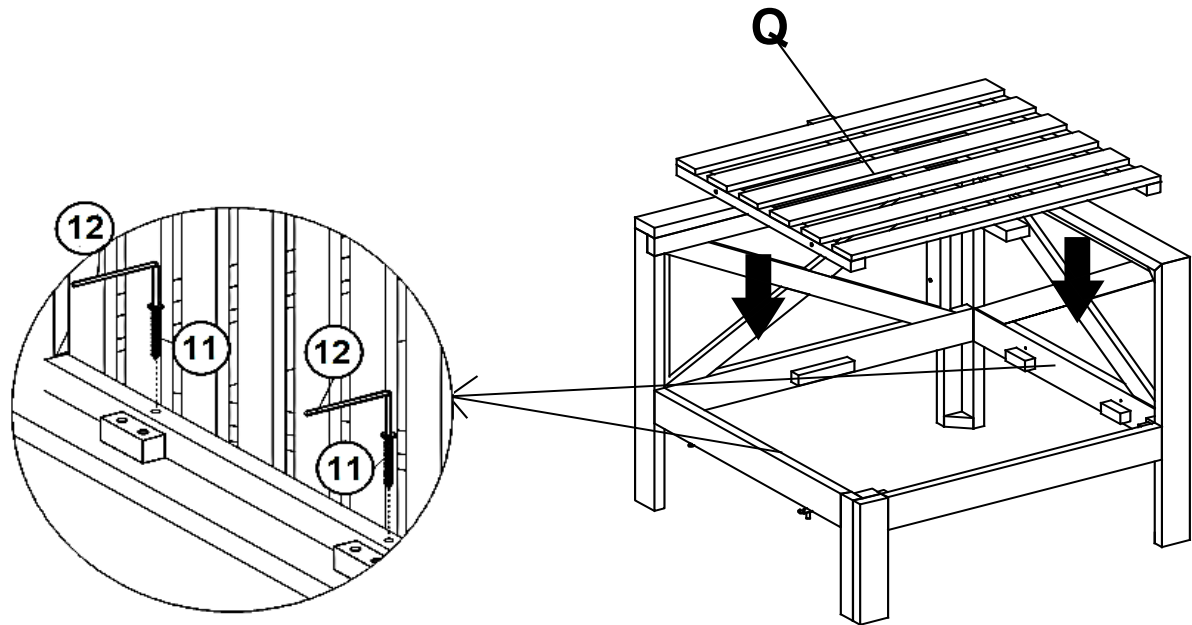

Stand the Chair frame up.

Insert Seat Panel (Q) onto Chair frame as shown above.

Attach Seat Panel (Q) with Chair by using Screws (11) with Allen Key (12).

Note: Using Screws (11) from inside to outside of Seat Panel (Q)

DO NOT FULLY TIGHTEN SCREWS.

Step 5

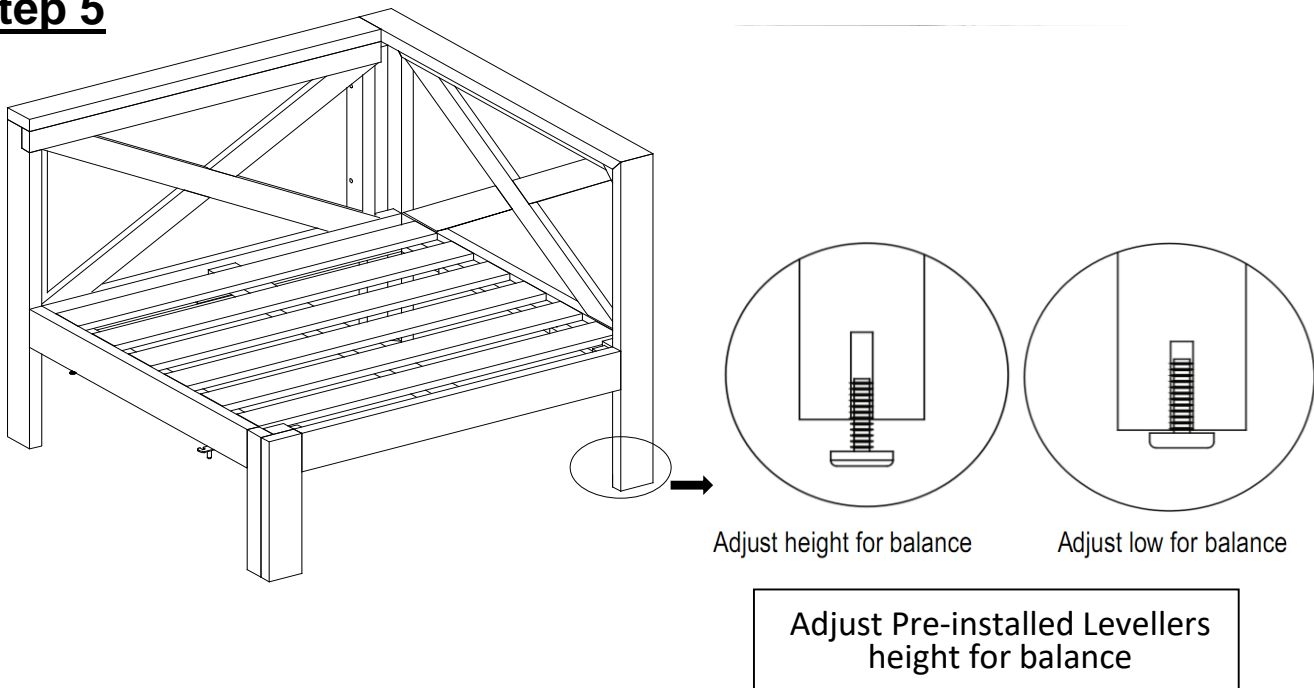

Inspect the Chair and make sure all parts are adequately connected.

Carefully sit onto the Chair. This pressure will help align all parts at all joints.

In a sequential manner, tighten all Bolts and Screws at all joints.

Adjust the Levellers until the Chair is level with the ground.

To adjust the Levellers, get assistance from an adult partner to lift/lean and hold the Chair while you are working.

Step 6

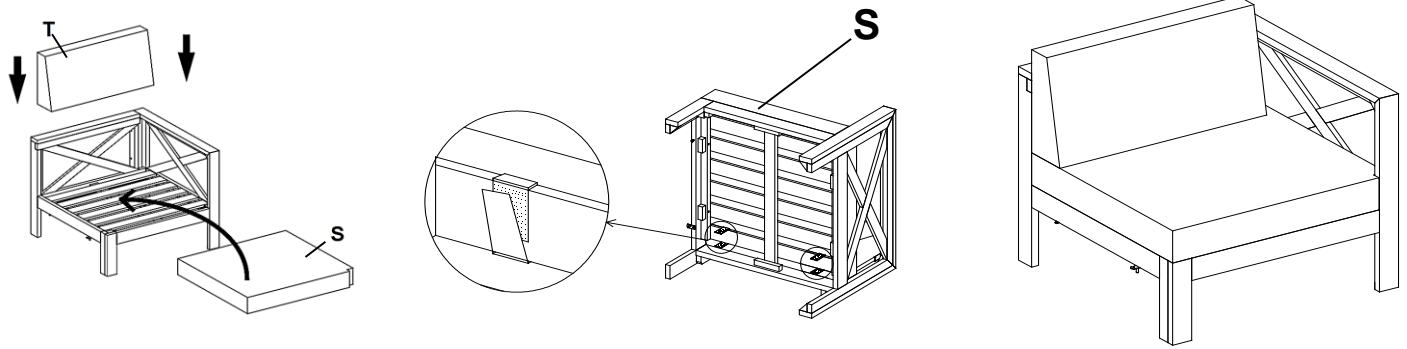

Place Seat Cushion (S) and Back Cushion (T) onto the Chair, and affix the velcro of Seat Cushion (S) straps around the Chair as shown above.

The Chair is ready to be used.

This Chair can only be used on a flat, level surface.



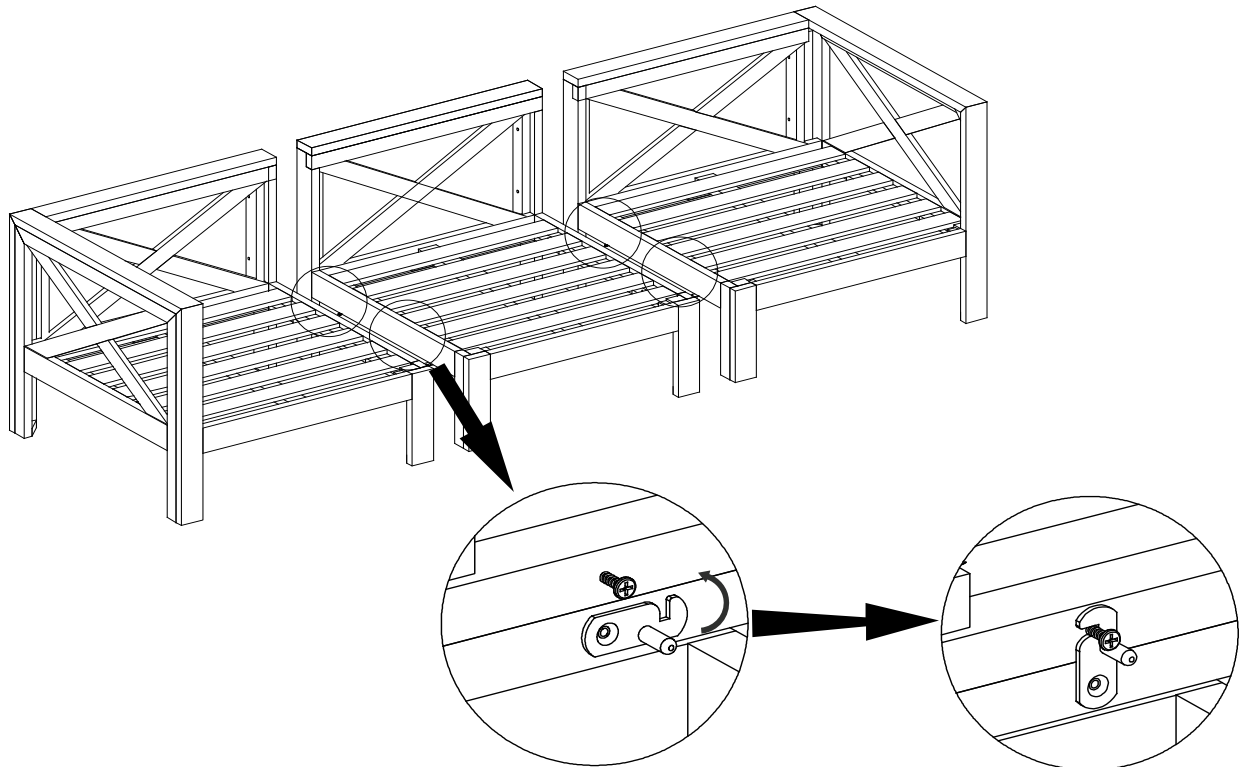





Step 7



With assistance from your adult partners, place the Chairs facedown and connect the pre-attached clips to connect the Chairs together.

Note: This is an optional step in case you want to connect all the Chairs in the set together and should be performed before affixing the cushions.

Care & Maintenance

-  Do not put hot items directly on furniture surface
 -  Do not clean furniture with harsh cleansers or polish.
 -  To obtain the longest lifespan of your outdoor products, minimizing exposure to direct sunlight is recommended.
 -  Children should not climb or jump on the furniture.
 -  Do not write on furniture without a padded barrier to protect the surface.
 -  To obtain the longest lifespan of your outdoor products, avoid extended and lengthy exposure to rain, snow, and direct sunshine. Whenever possible cover the product and /or place under patio or awnings.
 -  Not for commercial use. For residential use only .
 -  Stains may be removed with mild soap solution and damp cloth.
-
-  Dust and pick-up spills using a clean, non-colored, lint-free cloth .