

Parts List - Liste des pièces - Lista de partes

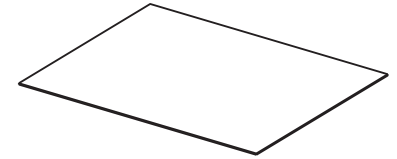
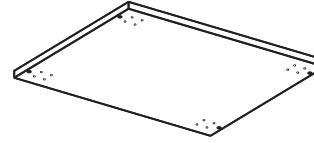
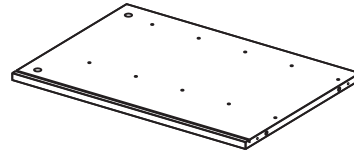
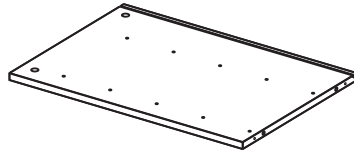
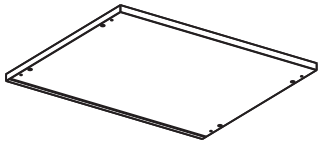

A	Top Panel Panneau supérieur Tapa		
Quantity Quantité Cantidad	1	Replace Remplacer Reemplazar	

B	Left Panel Panneau gauche Panel izquierdo		
Quantity Quantité Cantidad	1	Replace Remplacer Reemplazar	

C	Right Panel Panneau droit Panel derecho		
Quantity Quantité Cantidad	1	Replace Remplacer Reemplazar	

D	Bottom Panel Panneau inférieur Panel de abajo		
Quantity Quantité Cantidad	1	Replace Remplacer Reemplazar	

E	Back Panel Panneau arrière Panel de atrás		
Quantity Quantité Cantidad	1	Replace Remplacer Reemplazar	

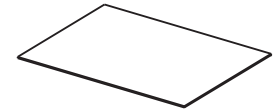
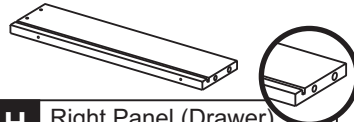
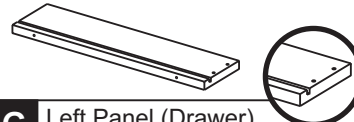

F1	Front Panel (Drawer) Panneau avant (Tiroir) Panel de enfrente (Cajon)		
Quantity Quantité Cantidad	5	Replace Remplacer Reemplazar	

G	Left Panel (Drawer) Panneau gauche (tiroir) Panel izquierdo (cajon)		
Quantity Quantité Cantidad	5	Replace Remplacer Reemplazar	

H	Right Panel (Drawer) Panneau droit (tiroir) Panel derecho (cajon)		
Quantity Quantité Cantidad	5	Replace Remplacer Reemplazar	

I1	Back Panel (Drawer) Panneau arrière (tiroir) Panel de atrás (cajon)		
Quantity Quantité Cantidad	5	Replace Remplacer Reemplazar	

J1	Bottom Board (Drawer) Conseil inférieur (tiroir) Base de abajo (cajon)		
Quantity Quantité Cantidad	5	Replace Remplacer Reemplazar	

Parts List - Liste des pièces - Lista de partes

* Screw Driver is required and not included in the package. * Un tournevis est nécessaire mais n'est pas inclus avec cet ensemble. * Se requiere desarmador de cruz y no viene incluido.

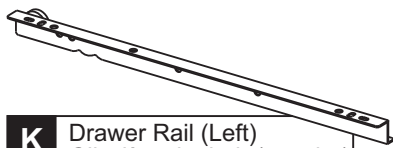

K	Drawer Rail (Left) Glissière de tiroir (gauche) Brasadera (izquierda)		
Quantity Quantité Cantidad	5	Replace Remplacer Reemplazar	

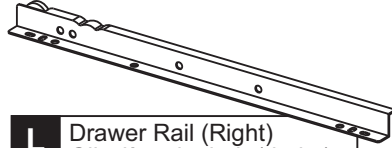

L	Drawer Rail (Right) Glissière de tiroir (droite) Brasadera (derecha)		
Quantity Quantité Cantidad	5	Replace Remplacer Reemplazar	

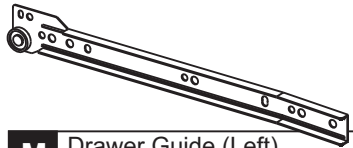

M	Drawer Guide (Left) Coulisse à tiroir (gauche) Pista de cajón (izquierdo)		
Quantity Quantité Cantidad	5	Replace Remplacer Reemplazar	

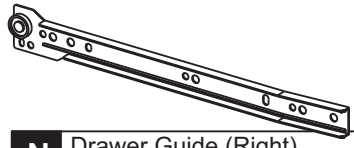

N	Drawer Guide (Right) Coulisse à tiroir (droit) Pista de cajón (derecho)		
Quantity Quantité Cantidad	5	Replace Remplacer Reemplazar	

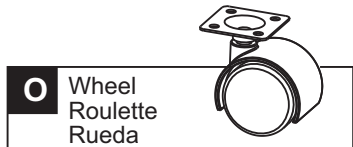

O	Wheel Roulette Rueda		
Quantity Quantité Cantidad	2	Replace Remplacer Reemplazar	

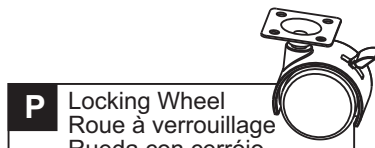

P	Locking Wheel Roue à verrouillage Rueda con cerrójo		
Quantity Quantité Cantidad	2	Replace Remplacer Reemplazar	

Q1	Small Wood Dowel Petite Goujon en bois Clavija pequeño de madera	
Quantity Quantité Cantidad	10	Replace Remplacer Reemplazar

Q2	Large Wood Dowel Grande Goujon en bois Clavija grande de madera	
Quantity Quantité Cantidad	8	Replace Remplacer Reemplazar

R	Gusset Gousset Esquinero	
Quantity Quantité Cantidad	4	Replace Remplacer Reemplazar

S	Small Cam Lock* Petite serrure batteuse* Pequeño cam-lock*	
Quantity Quantité Cantidad	10	Replace Remplacer Reemplazar

T	Cam Lock Screw* - Short Vis à blocage rapide* - Courte Tornillo para cam-lock* - Corto	
Quantity Quantité Cantidad	10	Replace Remplacer Reemplazar

U	Large Cam Lock* Grande serrure batteuse* Grande cam-lock*	
Quantity Quantité Cantidad	4	Replace Remplacer Reemplazar

V	Cam Lock Screw* - Long Vis à blocage rapide* - Long Tornillo para cam-lock* - Largo	
Quantity Quantité Cantidad	4	Replace Remplacer Reemplazar

W1	Phillips Screw* (Long) Vis phillips* (long) Tornillo phillips* (long)	
Quantity Quantité Cantidad	4	Replace Remplacer Reemplazar

W2	Phillips Screw* (Medium) Vis phillips* (du milieu) Tornillo phillips* (en medio)	
Quantity Quantité Cantidad	20	Replace Remplacer Reemplazar

For drawer rail & wheel
Pour glissière de tiroir & roulette
Para brasadera & rueda

W3	Phillips Screw* Vis phillips* Tornillo phillips*	
Quantity Quantité Cantidad	36	Replace Remplacer Reemplazar

For gusset
Pour gousset
Para esquinero

W4	Phillips Screw* Vis phillips* Tornillo phillips*	
Quantity Quantité Cantidad	4	Replace Remplacer Reemplazar

For drawer guide
Pour coulisse à tiroir
Para pista de cajón

W5	Phillips Screw* Vis phillips* Tornillo phillips*	
Quantity Quantité Cantidad	20	Replace Remplacer Reemplazar

Overall View - Vue totale - Vista total

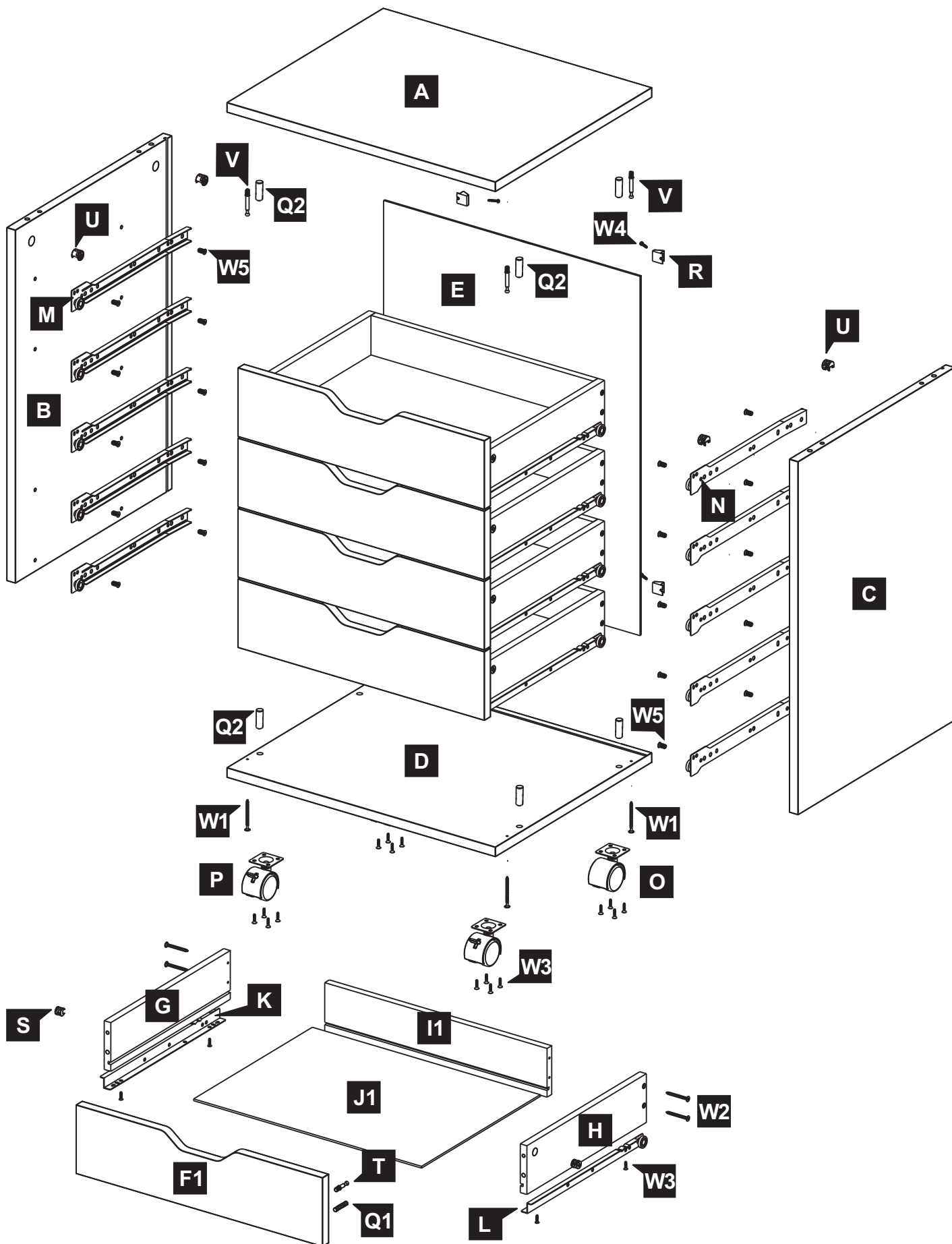

Assembly Instructions - Instructions d'assemblage - Instrucciones de ensamblaje

1

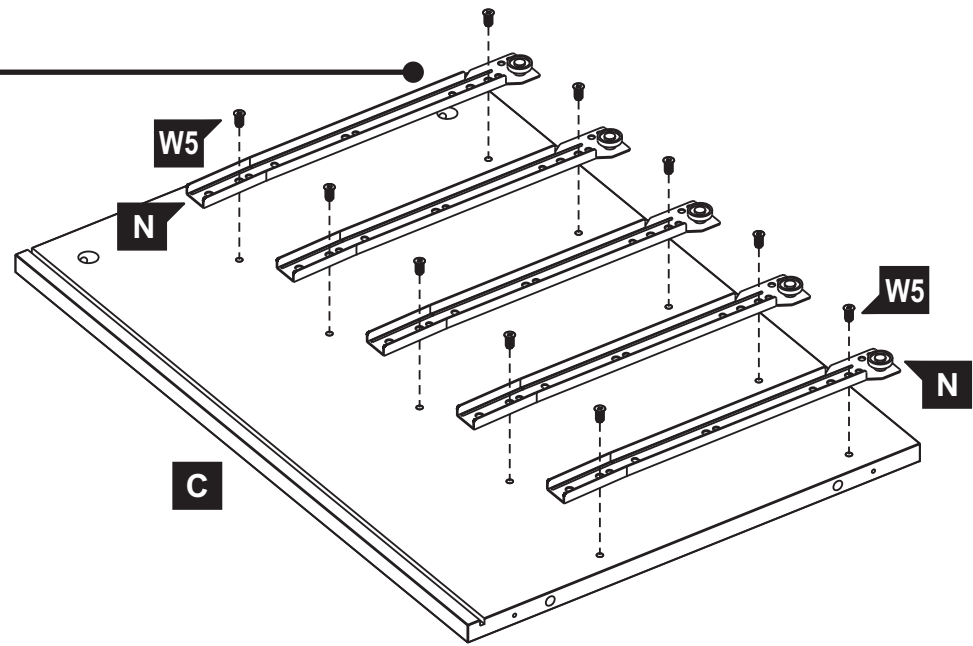
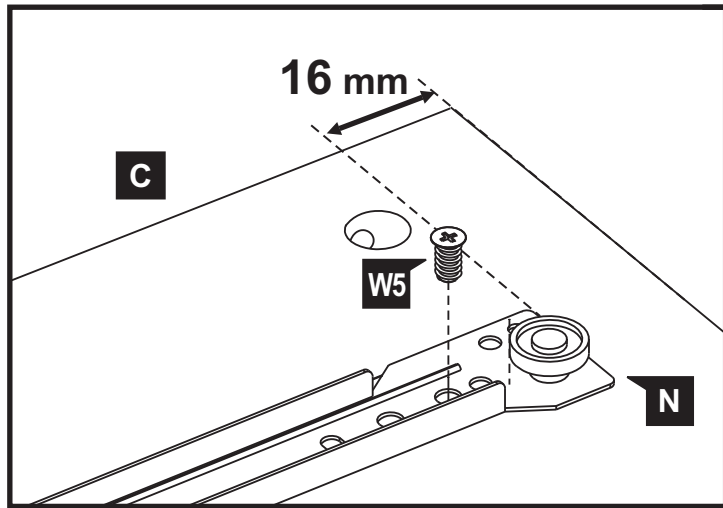
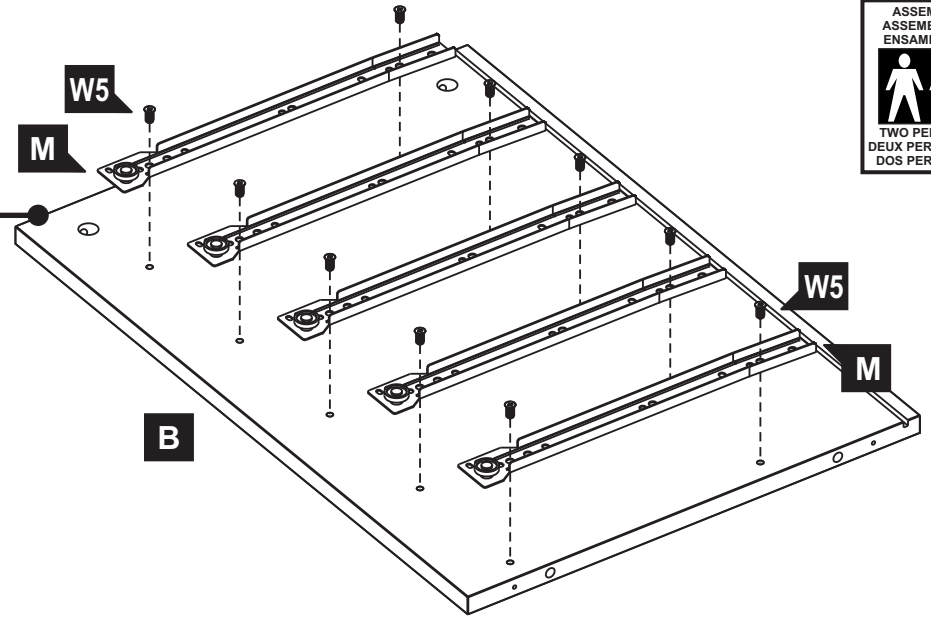
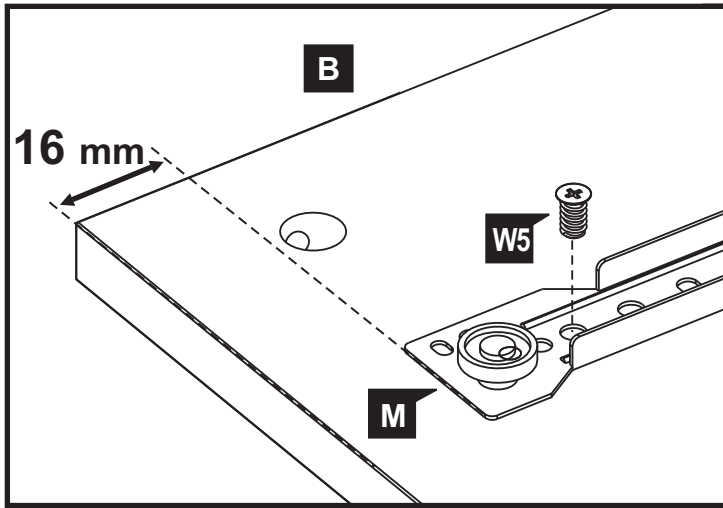



Assembly Instructions - Instructions d'assemblage - Instrucciones de ensamblaje

2

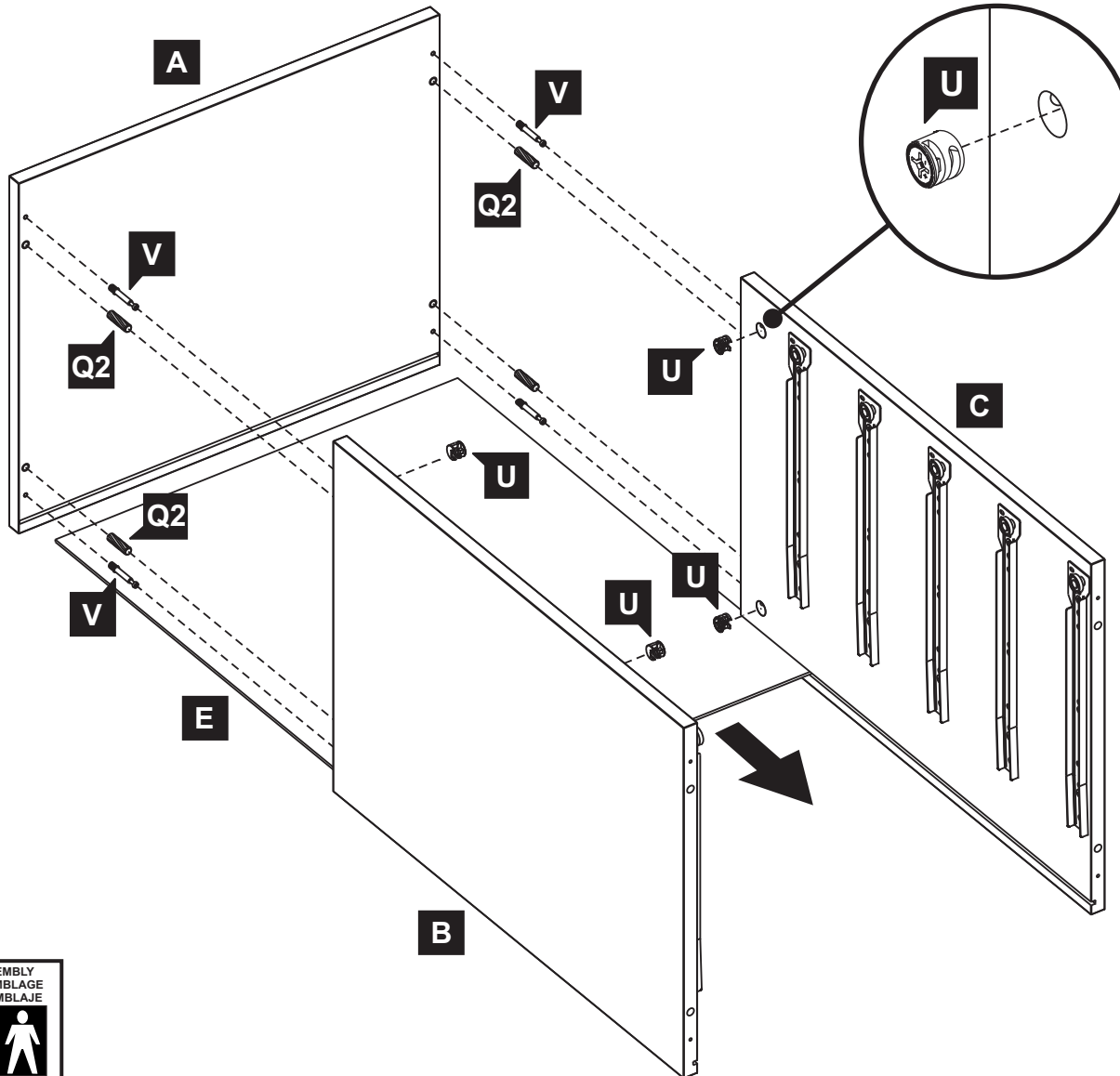

Tip: Recommend to have helping hands for this step.
 Conseil : demandez de l'aide pour cette étape.
 Consejo: Se recomienda que le ayuden para este paso.



U 

Note:
 Insert cam-lock in open position, rotate to open position with screw driver if necessary.

Remarque:
 Insérez la serrure batteuse en position ouverte, tournez en position ouverte avec le tournevis si nécessaire.

Nota:
 Inserta el "cam-lock" en posición abierta, voltee en posición abierta con desarmador si es necesario.

Turn to lock with screw-driver.
Warning: Do Not over tighten cam lock.

Tourner pour verrouiller avec tournevis.
Avertissement : Ne pas trop serrer serrure batteuse.

Volteé para cerrar con desarmador.
Advertencia: No sobre-apriete cam-lock.



Assembly Instructions - Instructions d'assemblage - Instrucciones de ensamblaje

3

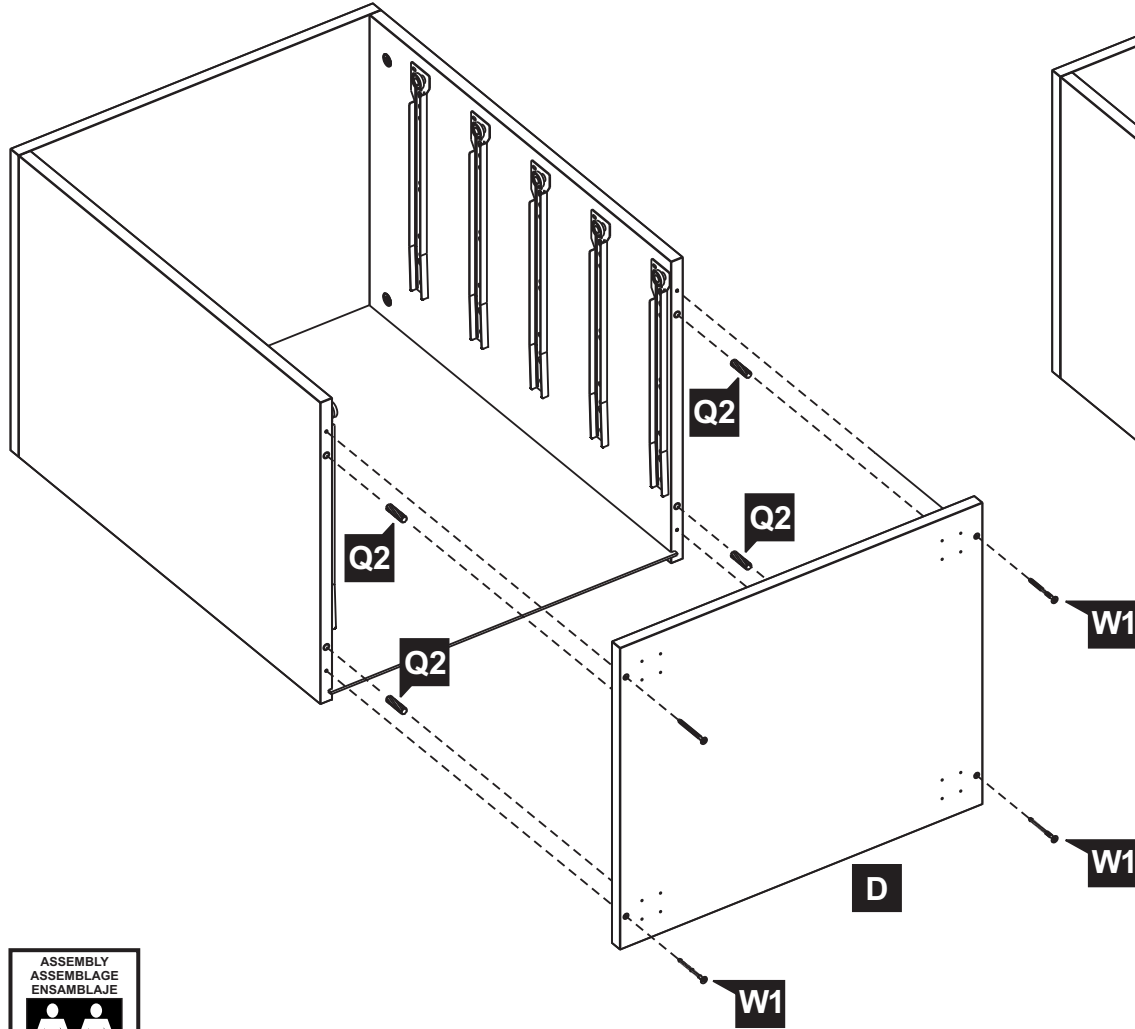

4

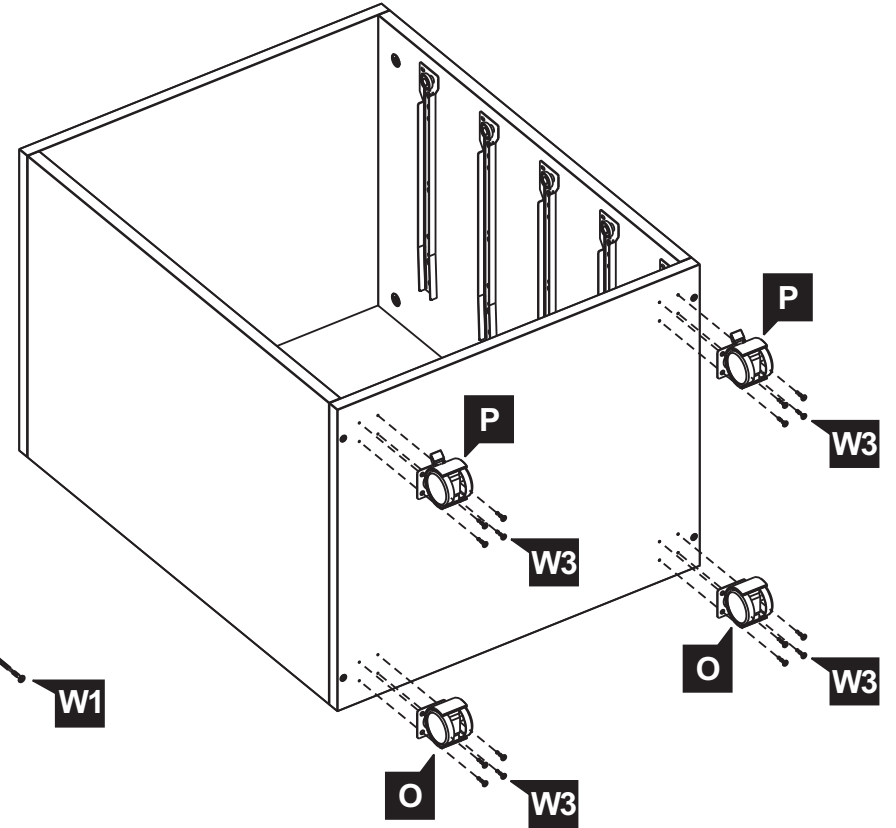

Assembly Instructions - Instructions d'assemblage - Instrucciones de ensamblaje

5 Drawer
Tiroir x 5
Cajon

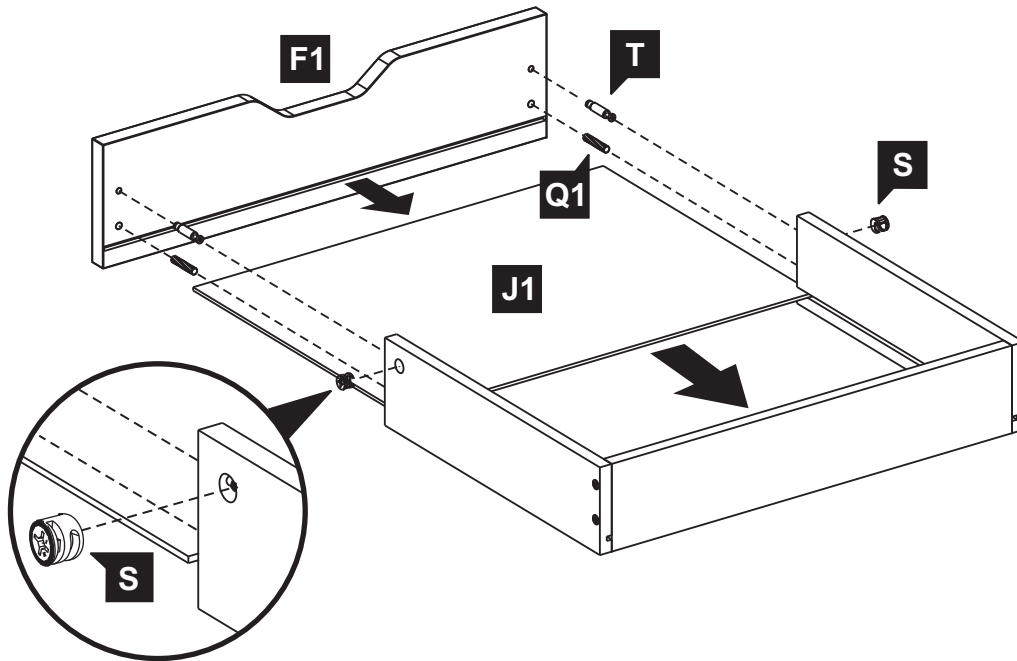
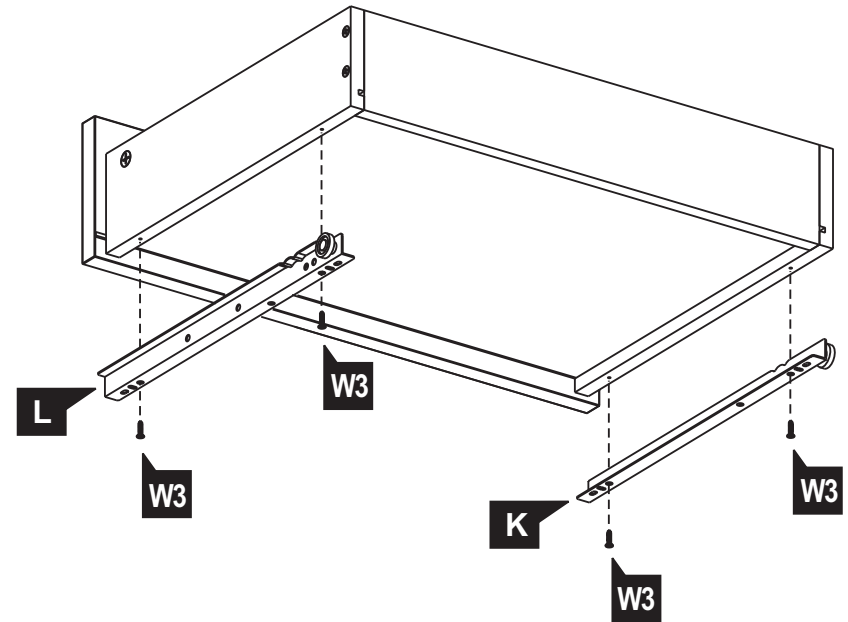
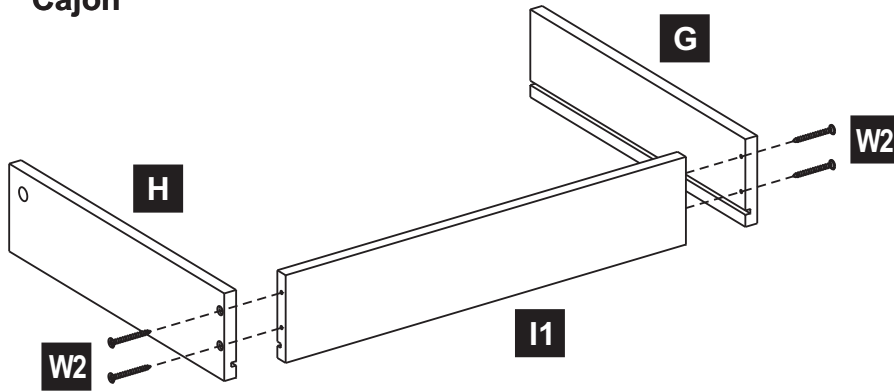

Note:
Insert cam-lock in open position, rotate to open position with screw driver if necessary.

Remarque:
Insérez la serrure batteuse en position ouverte, tourner en position ouverte avec le tournevis si nécessaire.

Nota:
Inserta el "cam-lock" en posición abierta, volteé en posición abierta con desarmador si es necesario.

Turn to lock with screw-driver.
Warning: Do Not over tighten cam lock.

Tourner pour verrouiller avec tournevis.
Avertissement : Ne pas trop serrer serrure batteuse.

Volteé para cerrar con desarmador.
Advertencia: No sobre-apriete cam-lock.

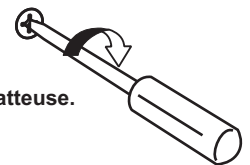

Assembly Instructions - Instructions d'assemblage - Instrucciones de ensamblaje

6

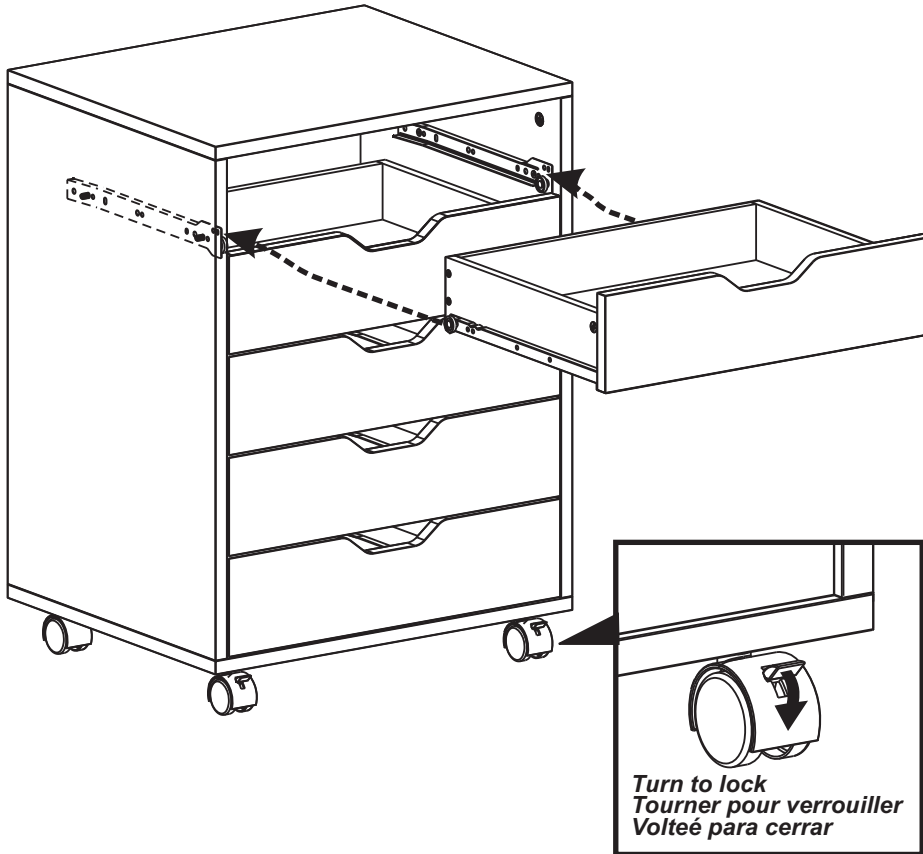

7



Back Panel
Panneau arrière
Panel de atrás

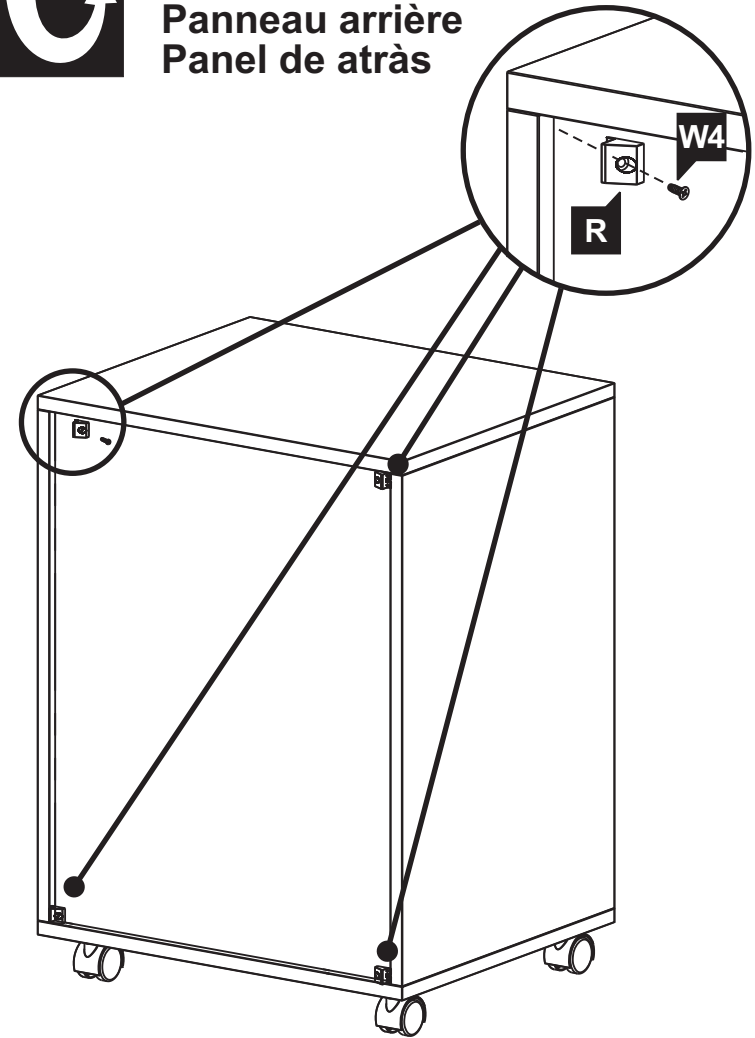

Care instructions:

To clean, wipe with wet cloth and dry thoroughly. Use mild soap if necessary. Avoid use of commercial waxes or polishes or abrasive cleaning materials.

Instructions d'entretien:

Pour nettoyer, essuyez avec un linge humide et séchez à fond. Utilisez un savon doux au besoin. Évitez d'utiliser des cires ou produits à polir de type commercial ou des matériaux de nettoyage abrasifs.

Instrucciones para el cuidado:

Para limpiar, frótelo con algo húmedo y séquelo bien. Use un jabón suave si es necesario. Evite el uso de ceras o pulidores comerciales o materiales abrasivos.